



TRINITY GLASS
INTERNATIONAL

33615 1st Way S, Federal Way, WA 98003

3'0 X 6'8 FLUSH GLAZED FIBERGLASS SINGLE DOOR WITH SIDELITES (CHS) IN SWING / OUTSWING "NON-IMPACT"

EVALUATED FOR USE IN THE STATE OF TEXAS

The Fiberglass Door system described herein complies with the 2018 International Residential Code (IRC), Sections R301 & R609 and the 2018 International Building Code (IBC), Sections 1404.13, 1609, 1709.5, 2403 and 2404 subject to the following conditions:

1. Anchors shall be as listed and spaced as shown in the details. Anchor embedment to base material shall be beyond wall dressing or stucco.
2. When used in areas requiring wind-borne debris protection this product is required to be protected with an impact resistant covering that complies with Section R301.2.1.2 of the IRC and Section 1609.2 of the IBC.
3. Allowable design pressure requirements must be equal to or less than the design pressure rating shown in the design pressure chart, sheet 1 of this drawing.
4. Conditions not covered by this drawing are subject to further engineering analysis.

TABLE OF CONTENTS

SHEET #	DESCRIPTION
1	Typical elevations, design pressures & general notes
2	Door panel construction details & glazing details
3	Sidelite panel construction details & glazing details
4	Horizontal cross sections
5	Vertical cross sections
6	Vertical cross sections
7	Frame anchoring
8	Components
9	Bill of materials & components

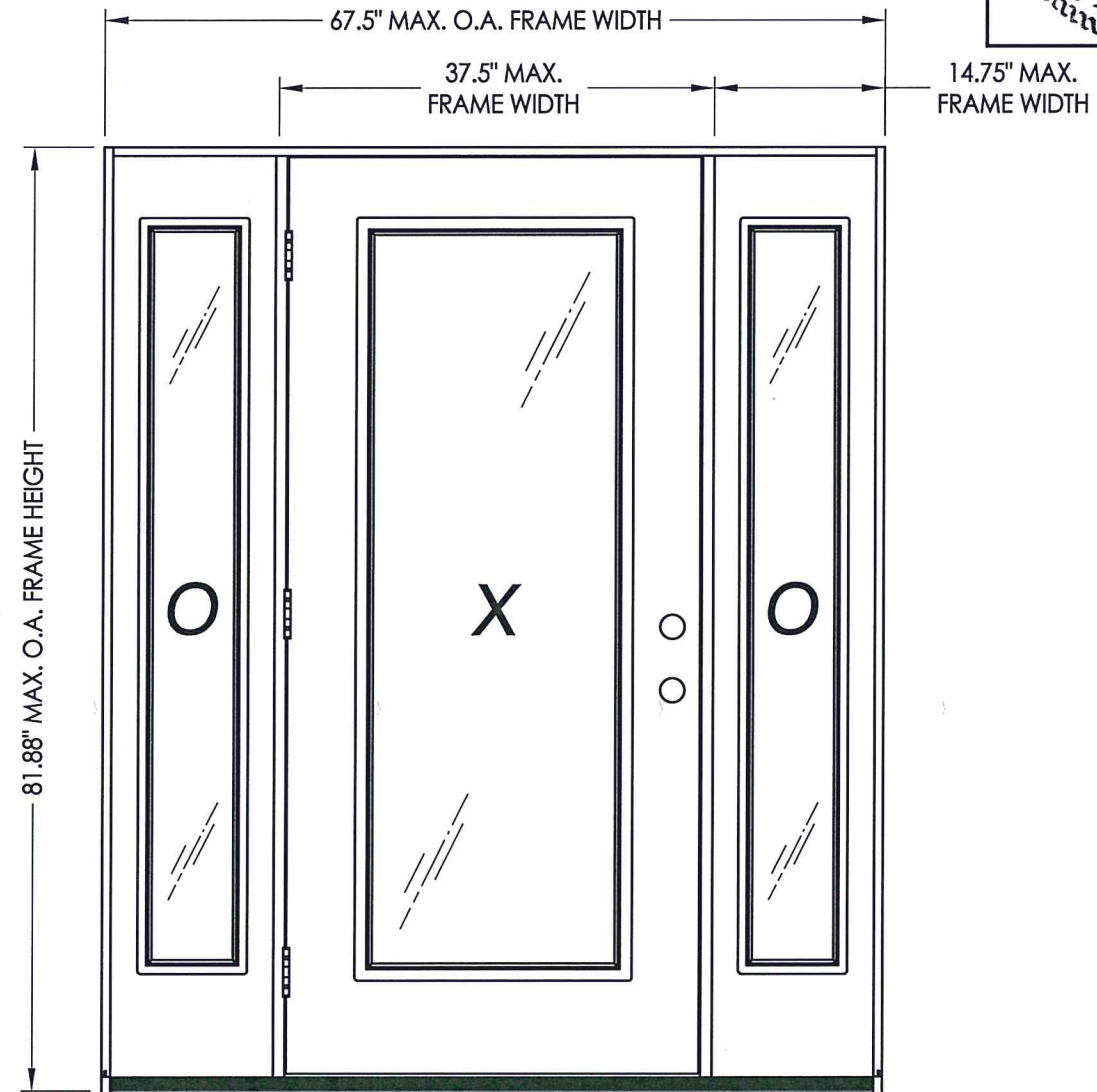

CONTINUOUS HEADER AND SILL

SWING	MAX. FRAME DIMENSION	GLASS TYPE	DESIGN PRESSURE (PSF)	
			POSITIVE	NEGATIVE
IN SWING	67.50" x 81.88"	G1, G2 & G3	+60.0	-60.0
OUTSWING	67.50" x 80.75"	G1, G2 & G3	+60.0	-60.0

Refer to Table (sheet 4) for Passage Lock Rating Limitations



Documents Prepared By: Lyndon F. Schmidt, P.E.
TEXAS P.E. #104123

RW BUILDING CONSULTANTS, INC.
P.O. Box 230 Valrico FL, 33595
Phone No.: 813.659.9197

TEXAS BOARD OF PROFESSIONAL ENGINEERS
CERTIFICATE OF REGISTRATION # F-11852

PRODUCT: TRINITY GLASS INT'L
6'8 FLUSH GLAZED

PART OR ASSEMBLY:
TYPICAL ELEVATION, DESIGN PRESSURES & GENERAL NOTES

NO.	DATE	REVISIONS
3	2/03/20	UPDATE TO 2018 IBC/IRC
2	7/27/09	TDI PRODUCT EVALUATION UPDATE
1	6/28/06	REVISED LOCKSET NOMENCLATURE

DATE: 8/29/05
SCALE: N.T.S.
DWG. BY: WH
CHK. BY: LFS
DRAWING NO.: TX-4036
SHEET 1 OF 9

R:\Clients\Trinity Glass PERMANENT\B - Texas Dept of Ins\DR 181\C - Drawings\DR-181 2018 IBC\TX-4036.dwg, 2

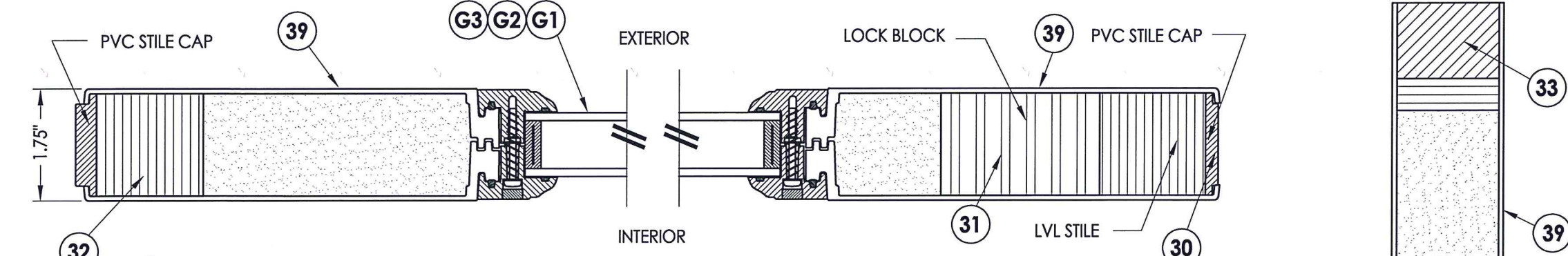

1 HORIZONTAL CROSS SECTION

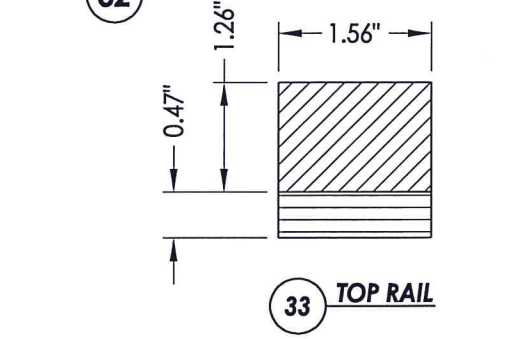

33 TOP RAIL

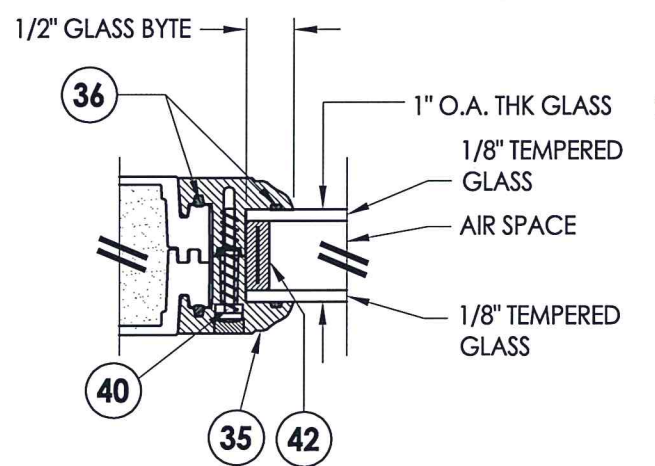

G1 GLAZING DETAIL

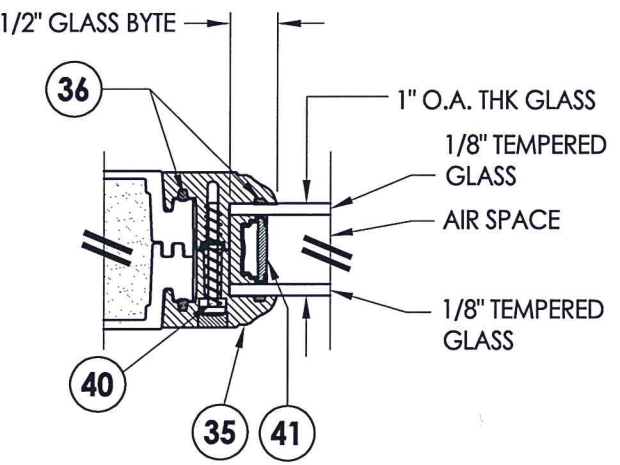

G2 GLAZING DETAIL

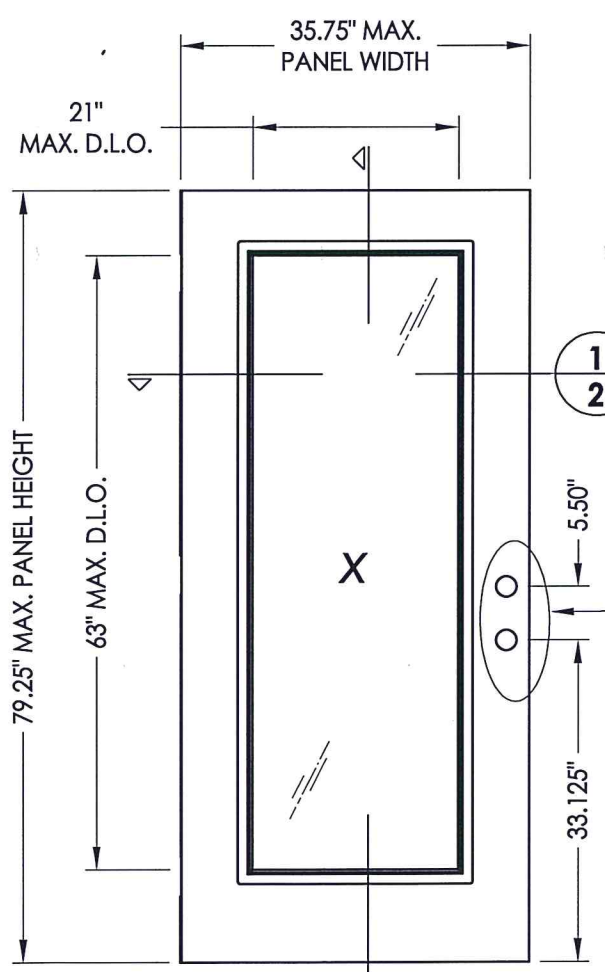

FLUSH GLAZED DOOR

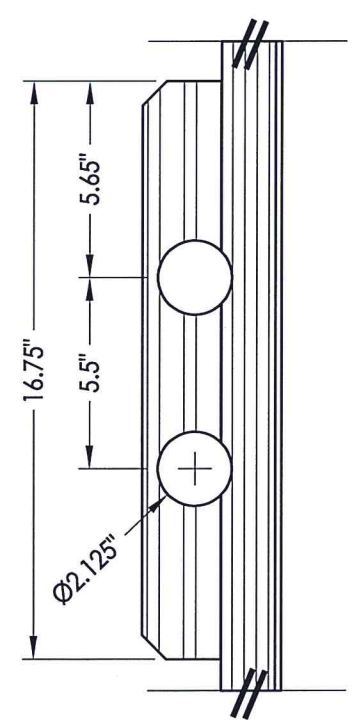

DETAIL 1

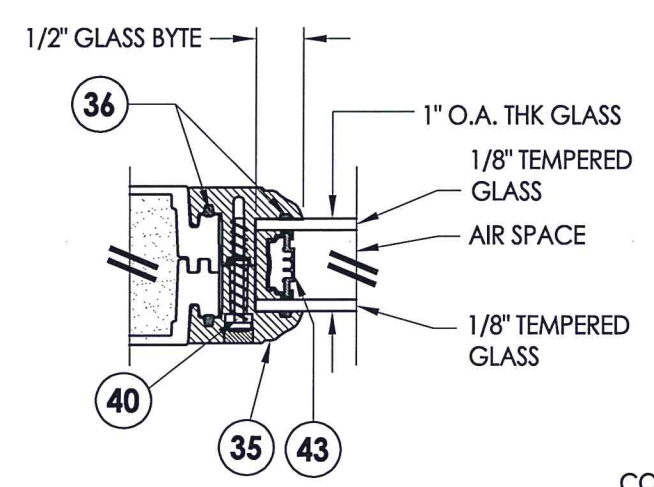

G3 GLAZING DETAIL

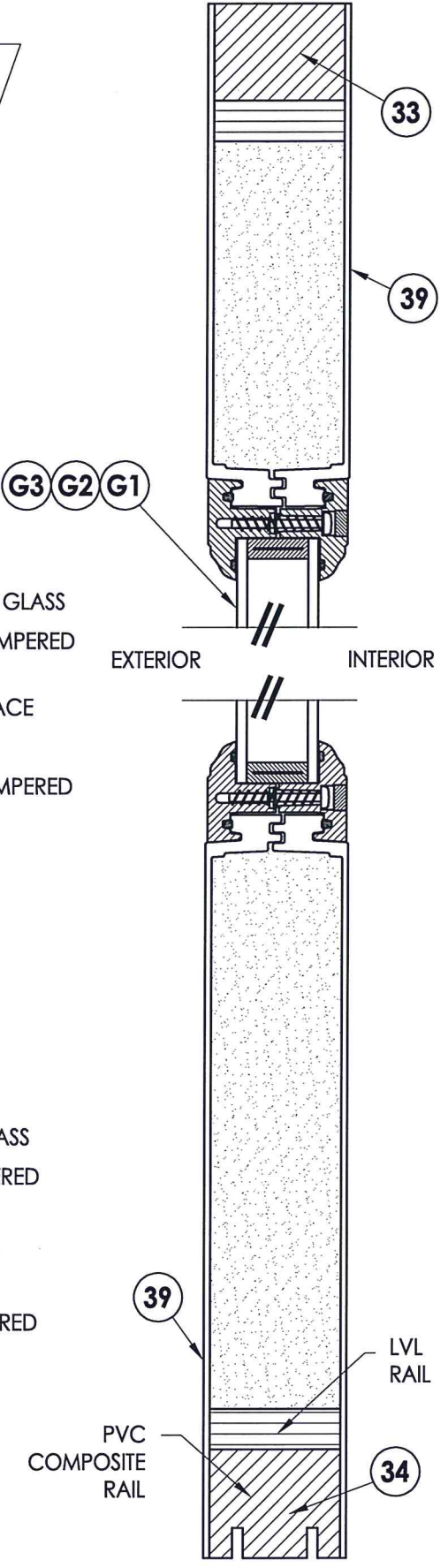

2 VERTICAL CROSS SECTION

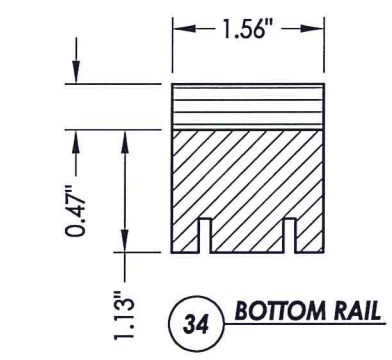

34 BOTTOM RAIL

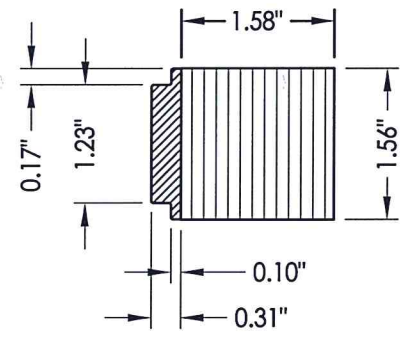

32 HINGE STILE

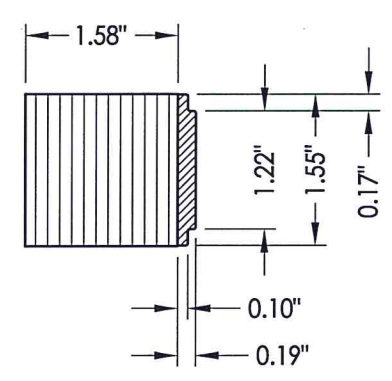

30 LATCH STILE

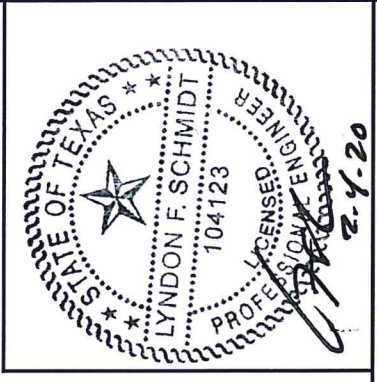

Documents Prepared By: Lyndon F. Schmidt, P.E.
TEXAS P.E. #104123

RW BUILDING CONSULTANTS, INC.
P.O. Box 230 Valrico FL, 33595
Phone No.: 813.659.9197
TEXAS BOARD OF PROFESSIONAL ENGINEERS
CERTIFICATE OF REGISTRATION # F-11852

PRODUCT: TRINITY GLASS INT'L
6-8 FLUSH GLAZED
PART OR ASSEMBLY:
DOOR PANEL CONSTRUCTION
DETAILS & GLAZING DETAILS

NO.	DATE	REVISIONS
3	2/03/20	UPDATE TO 2018 IBC/IRC LFS
2	7/27/09	TDI PRODUCT EVALUATION UPDATE AL
1	6/28/06	REVISED LOCKSET NOMENCLATURE EW

DATE: 8/29/05
SCALE: N.T.S.
DWG. BY: WH
CHK. BY: LFS
DRAWING NO.: TX-4036
SHEET 2 OF 9

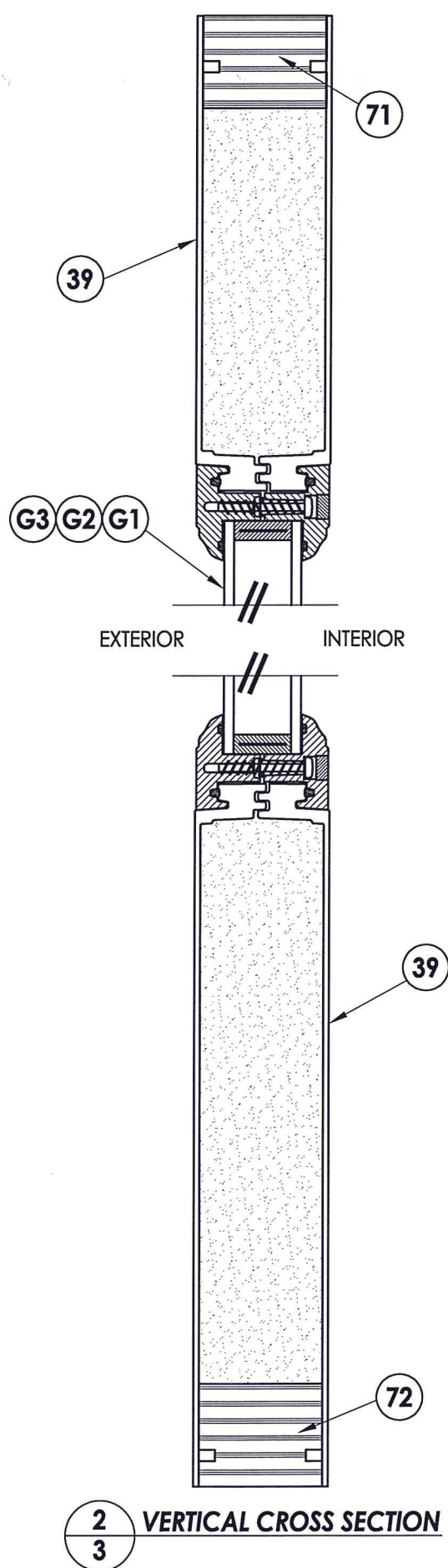
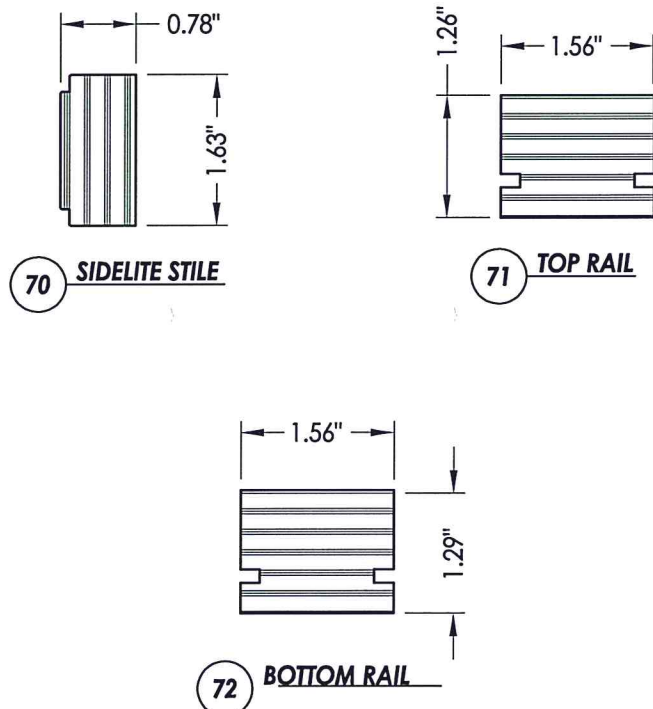
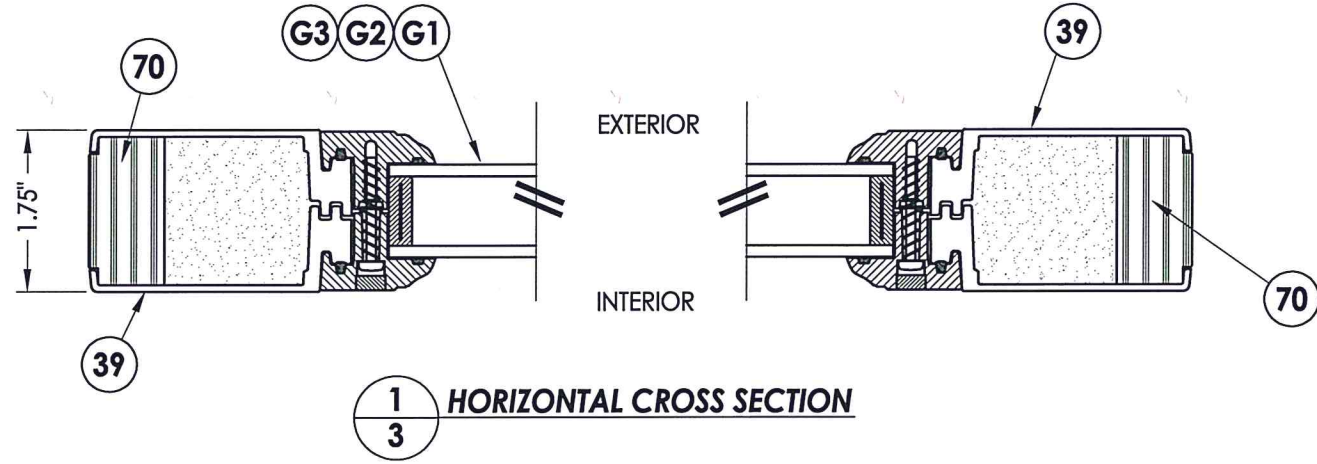
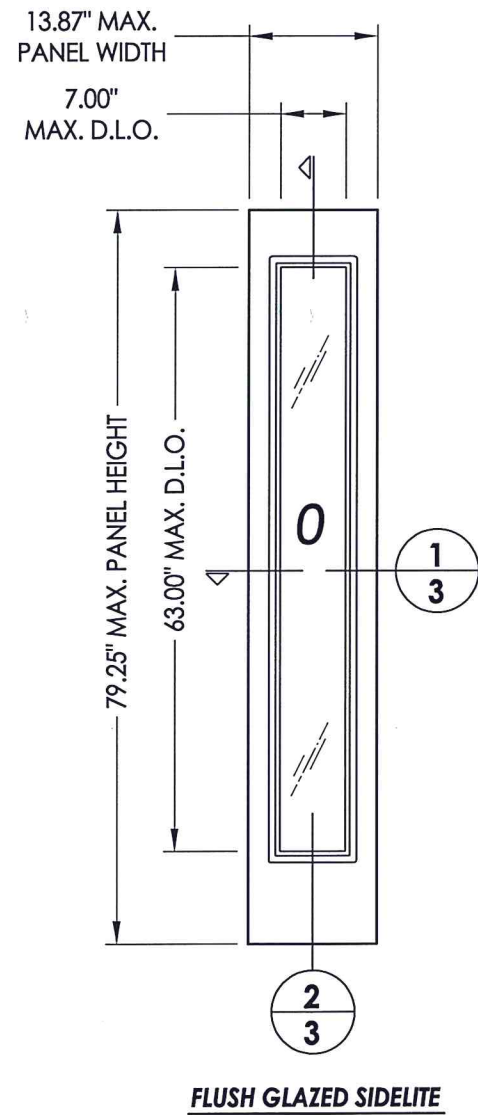

Documents Prepared By: Lyndon F. Schmidt, P.E.
TEXAS P.E. #104123

RW BUILDING CONSULTANTS, INC.
P.O. Box 230 Valrico FL 33595
Phone No.: 813.659.9197

TEXAS BOARD OF PROFESSIONAL ENGINEERS
CERTIFICATE OF REGISTRATION # F-11852

PRODUCT:		TRINITY GLASS INT'L 6 8 FLUSH GLAZED	
PART OR ASSEMBLY:		SIDELITE PANEL CONSTRUCTION DETAILS & GLAZING DETAILS	
NO.	DATE	REVISIONS	
3	2/03/20	UPDATE TO 2018 IBC/IRC	LFS
2	7/27/09	TDI PRODUCT EVALUATION UPDATE	AL
1	6/28/06	REVISED LOCKSET NOMENCLATURE	EW

DATE: 8/29/05
SCALE: N.T.S.
DWG. BY: WH
CHK. BY: LFS
DRAWING NO.: TX-4036
SHEET 3 OF 9

NOTE:

- Sidelite ass'y fastener: 6" from each end and 4 more screws equally spaced between (6 screws total per jamb).

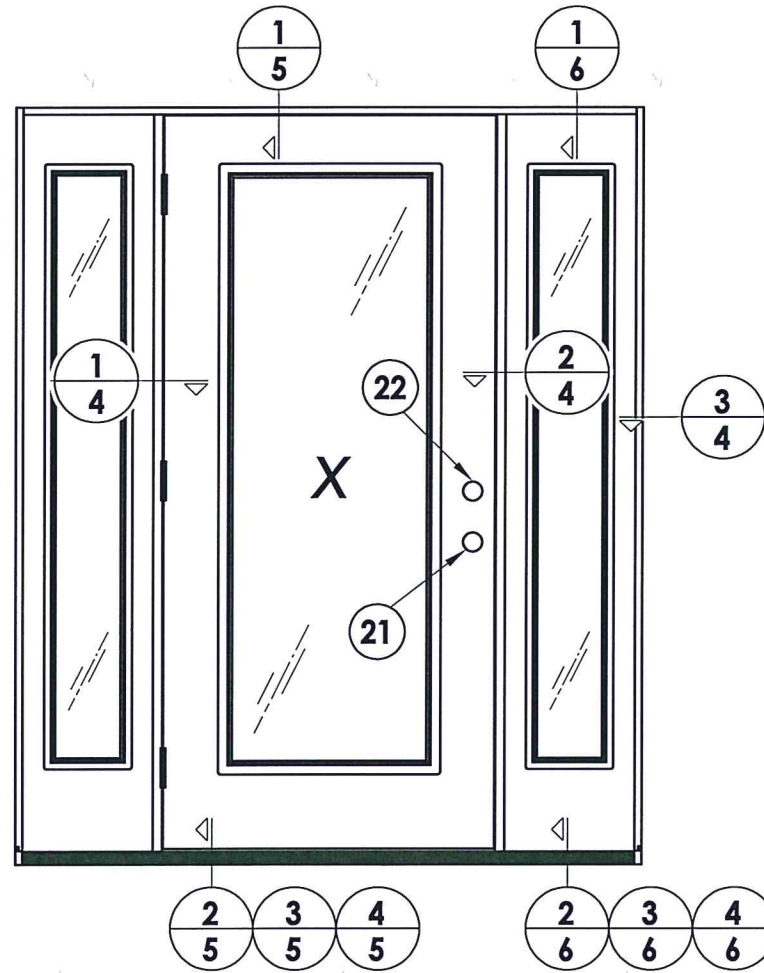

LOCK & DEADBOLT RATINGS CHART				
MANUFACTURER	MODEL	ITEM #	MAX. DESIGN PRESSURE (PSF)	
			POSITIVE	NEGATIVE
KWIKSET	LOCK: 740	21	+60.0	-60.0
	DEADBOLT: 780	22		
KWIKSET	LOCK: COMBO 660	21	+60.0	-60.0
	DEADBOLT: COMBO 660	22		
SCHLAGE	LOCK: MAX. SECURITY	21	+60.0	-60.0
	DEADBOLT: MAX. SECURITY	22		



Documents Prepared By: Lyndon F. Schmidt, P.E.
TEXAS P.E. #104123

RW BUILDING CONSULTANTS, INC.
P.O. Box 230 Valrico FL, 33595
Phone No.: 813.659.9197

TEXAS BOARD OF PROFESSIONAL ENGINEERS
CERTIFICATE OF REGISTRATION # F-11852

PRODUCT: TRINITY GLASS INT'L
6"8 FLUSH GLAZED

PART OR ASSEMBLY:
HORIZONTAL CROSS SECTIONS

NO.	DATE	REVISIONS
3	2/03/20	UPDATE TO 2018 IBC/IRC
2	7/27/09	TDI PRODUCT EVALUATION UPDATE
1	6/28/06	REVISED LOCKSET NOMENCLATURE
		BY

DATE: 8/29/05
SCALE: N.T.S.
DWG. BY: WH
CHK. BY: LFS
DRAWING NO.: TX-4036
SHEET 4 OF 9

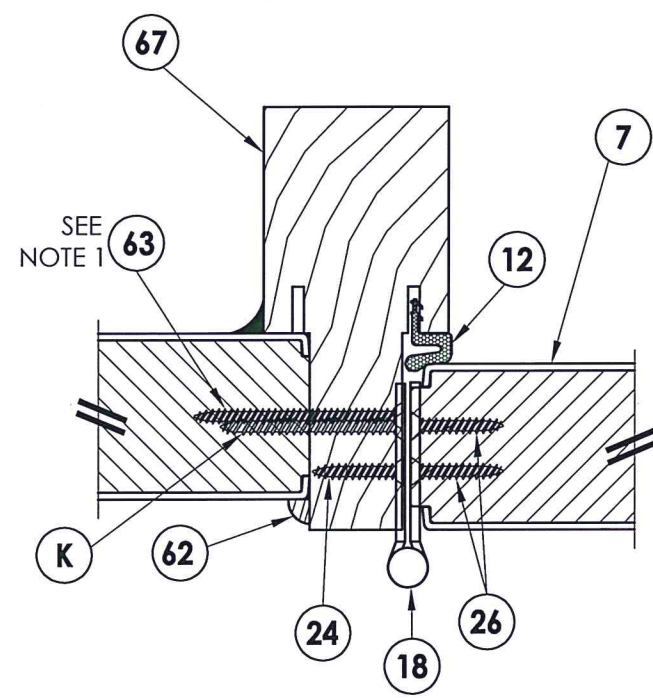

1 HORIZONTAL CROSS SECTION
4 Outswing shown
Inswing also approved

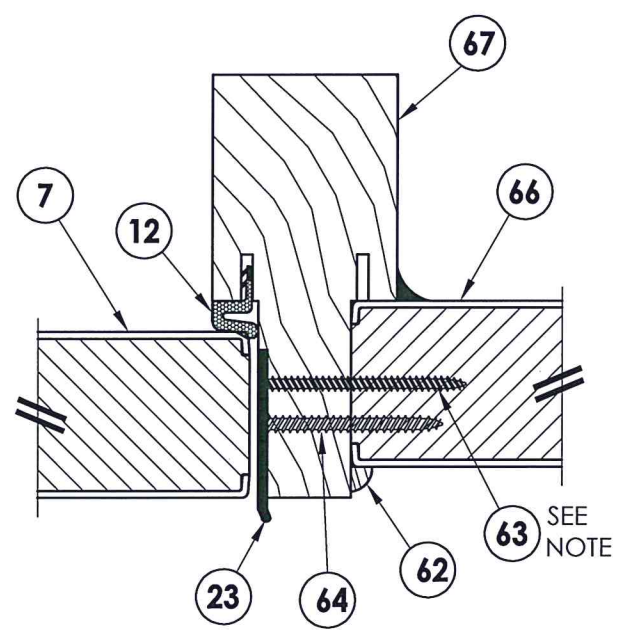

2 HORIZONTAL CROSS SECTION
4 Outswing shown
Inswing also approved

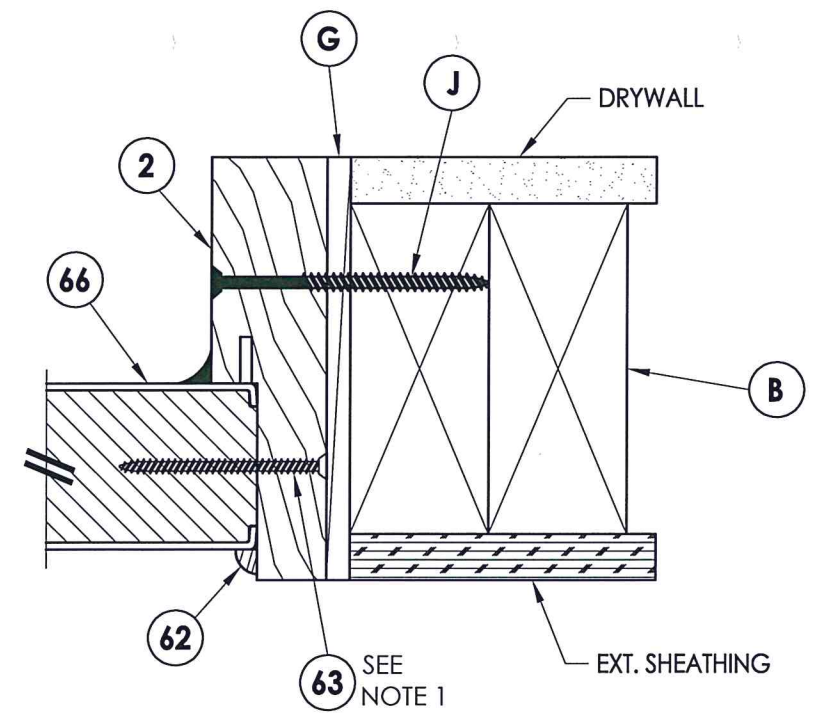

3 HORIZONTAL CROSS SECTION
4 Outswing shown
Inswing also approved

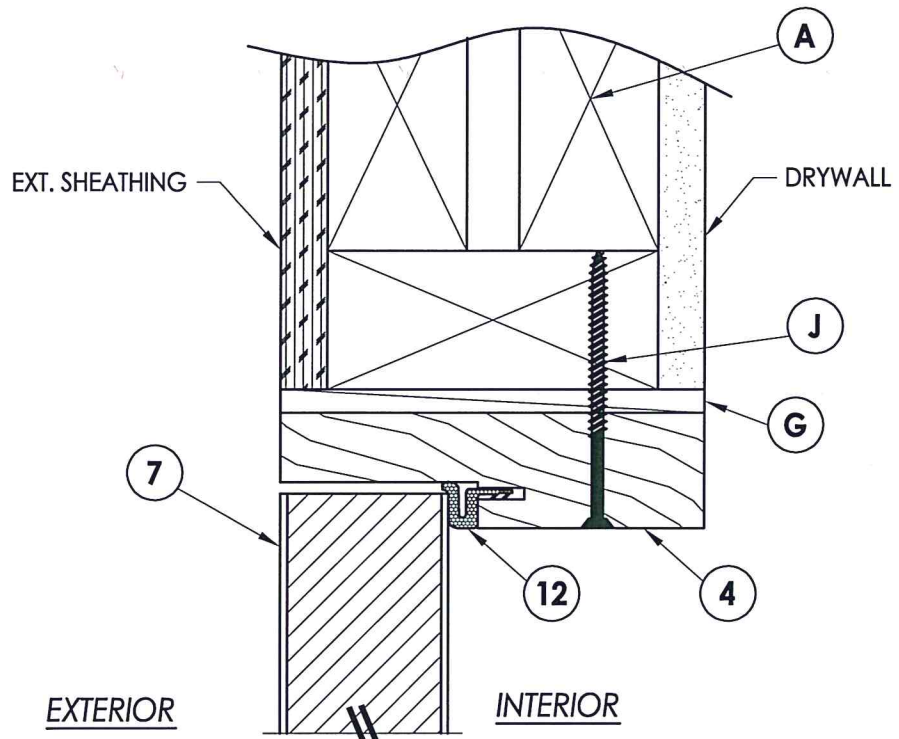

1 VERTICAL CROSS SECTION
5 Outswing shown
 Inswing also approved

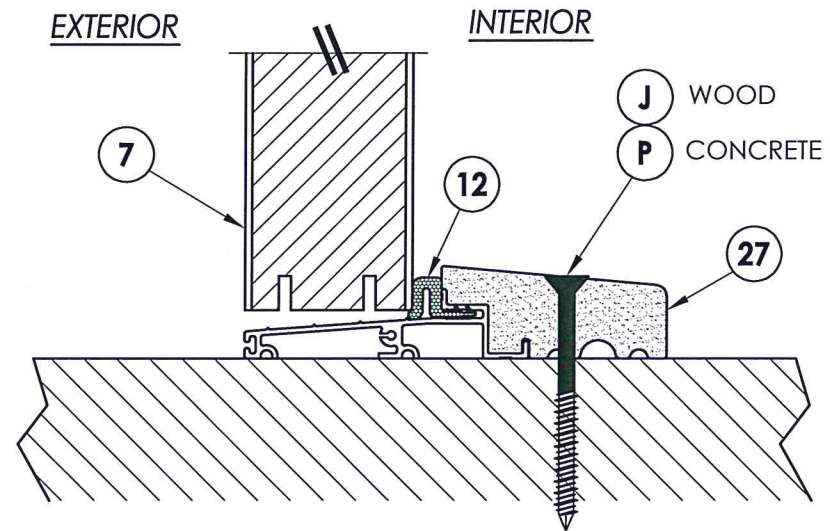

2 VERTICAL CROSS SECTION
5 Outswing configuration

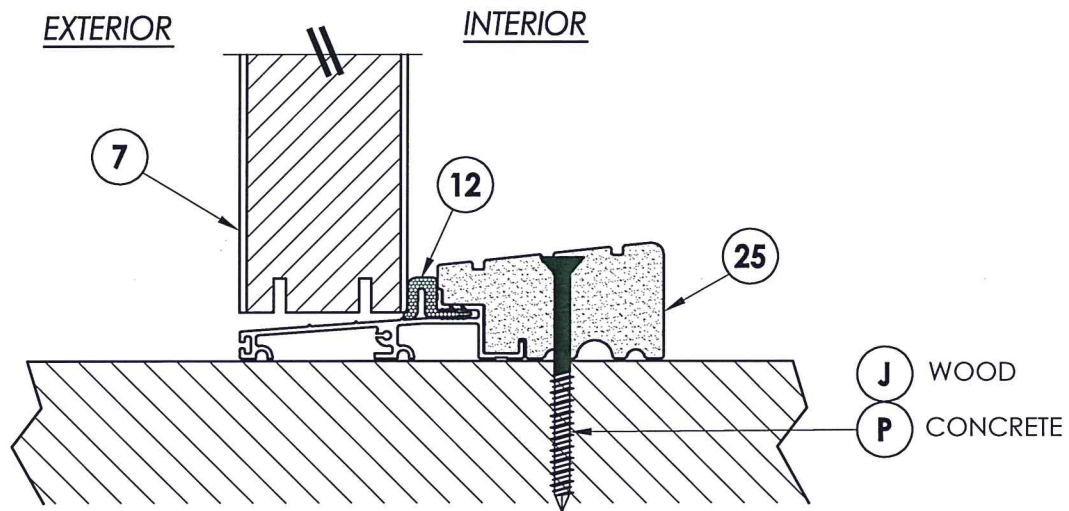

3 VERTICAL CROSS SECTION
5 Outswing configuration

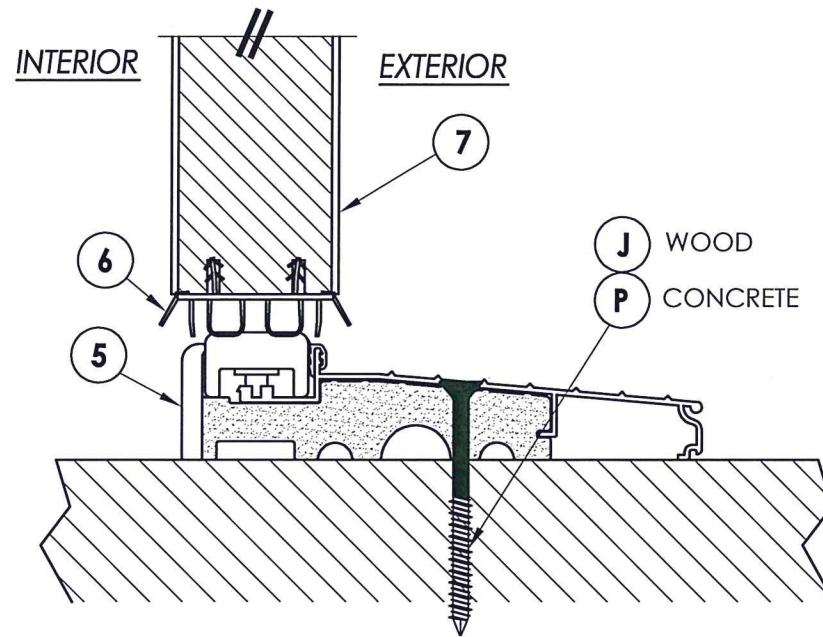

4 VERTICAL CROSS SECTION
5 Inswing configuration

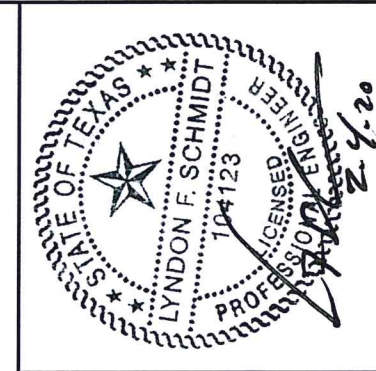

Documents Prepared By: Lyndon F. Schmidt, P.E.
 TEXAS P.E. #104123

RW BUILDING CONSULTANTS, INC.
 P.O. Box 230 Valrico FL, 33595
 Phone No.: 813.659.9197

TEXAS BOARD OF PROFESSIONAL ENGINEERS
 CERTIFICATE OF REGISTRATION # F-11852

PRODUCT: TRINITY GLASS INT'L
 6 8 FLUSH GLAZED

PART OR ASSEMBLY:
 VERTICAL CROSS SECTIONS

NO.	DATE	REVISIONS
3	2/03/20	UPDATE TO 2018 IBC/IRC
2	7/27/09	TDI PRODUCT EVALUATION UPDATE
1	6/28/06	REVISED LOCKSET NOMENCLATURE
		BY

DATE: 8/29/05
 SCALE: N.T.S.
 DWG. BY: WH
 CHK. BY: LFS
 DRAWING NO.: TX-4036
 SHEET 5 OF 9

R:\Clients\Trinity Glass PERMANENT\B - Texas Dept of Ins\DR 181\VC - Drawings\DR-181 2018 IBC\TX-4036.dwg, 6

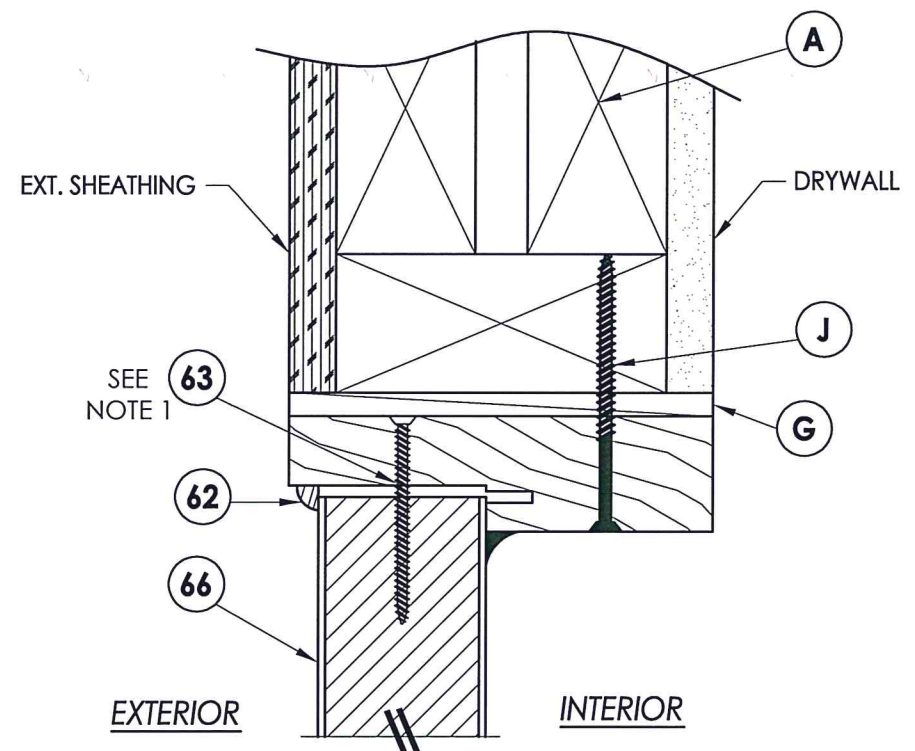

1 VERTICAL CROSS SECTION
6 Outwing shown
 Inswing also approved

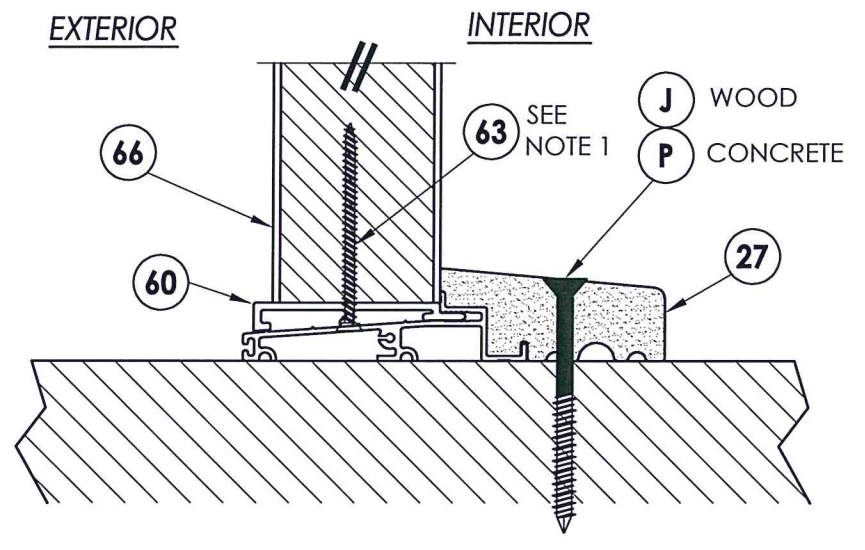

2 VERTICAL CROSS SECTION
6 Outwing configuration

NOTE:
 1. Screws thru head and sill jamb located 3" from each end and on center line.

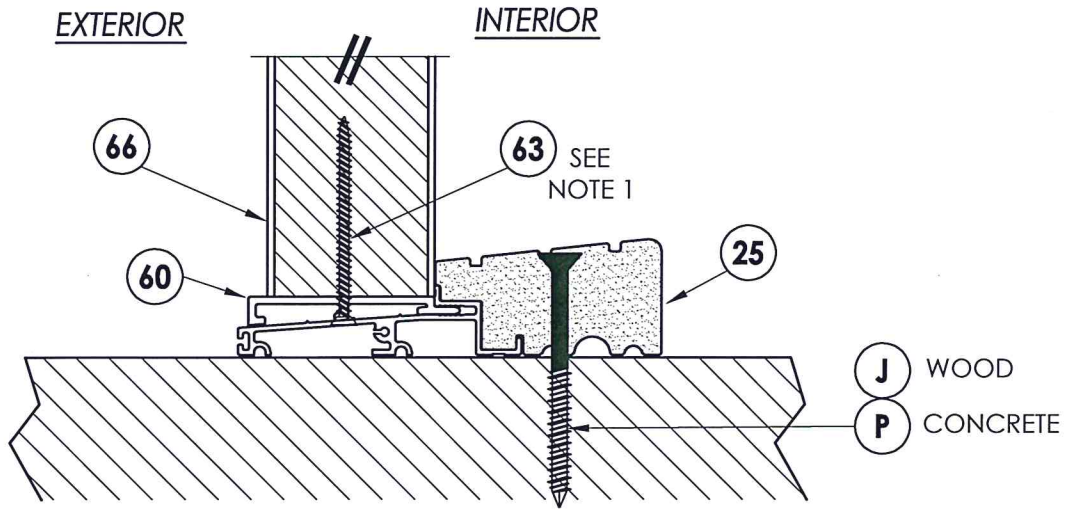

3 VERTICAL CROSS SECTION
6 Outwing configuration

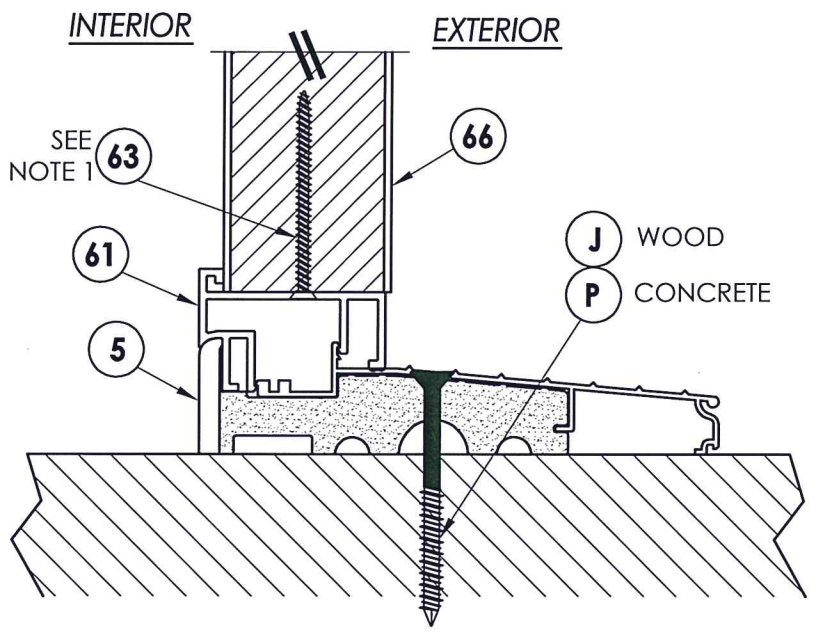

4 VERTICAL CROSS SECTION
6 Inswing configuration

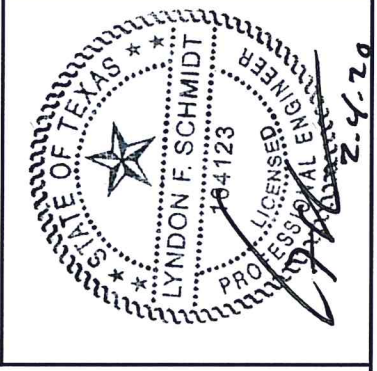

Documents Prepared By: Lyndon F. Schmidt, P.E.
 TEXAS P.E. #104123
RW BUILDING CONSULTANTS, INC.
 P.O. Box 230 Valrico FL, 33595
 Phone No.: 813.659.9197
 TEXAS BOARD OF PROFESSIONAL ENGINEERS
 CERTIFICATE OF REGISTRATION # F-11852

PRODUCT: TRINITY GLASS INT'L
 6 8 FLUSH GLAZED
 PART OR ASSEMBLY:
 VERTICAL CROSS SECTIONS

NO.	DATE	REVISIONS
3	2/03/20	UPDATE TO 2018 IBC/IRC
2	7/27/09	TDI PRODUCT EVALUATION UPDATE
1	6/28/06	REVISED LOCKSET NOMENCLATURE
		EW
		BY

DATE: 8/29/05
 SCALE: N.T.S.
 DWG. BY: WH
 CHK. BY: LFS
 DRAWING NO.: TX-4036
 SHEET 6 OF 9

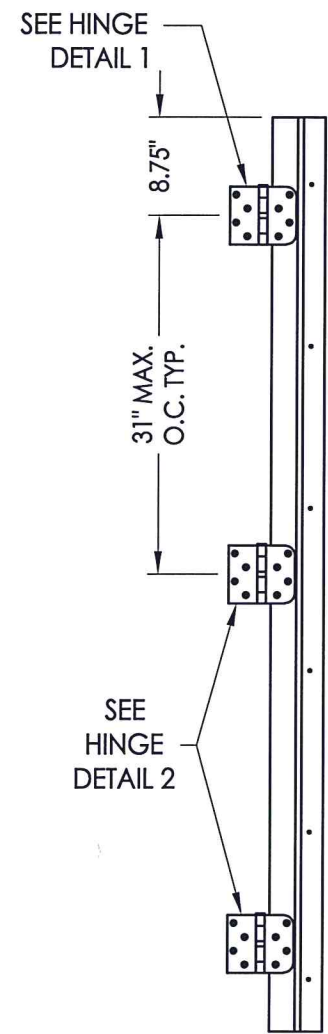

HINGE JAMB

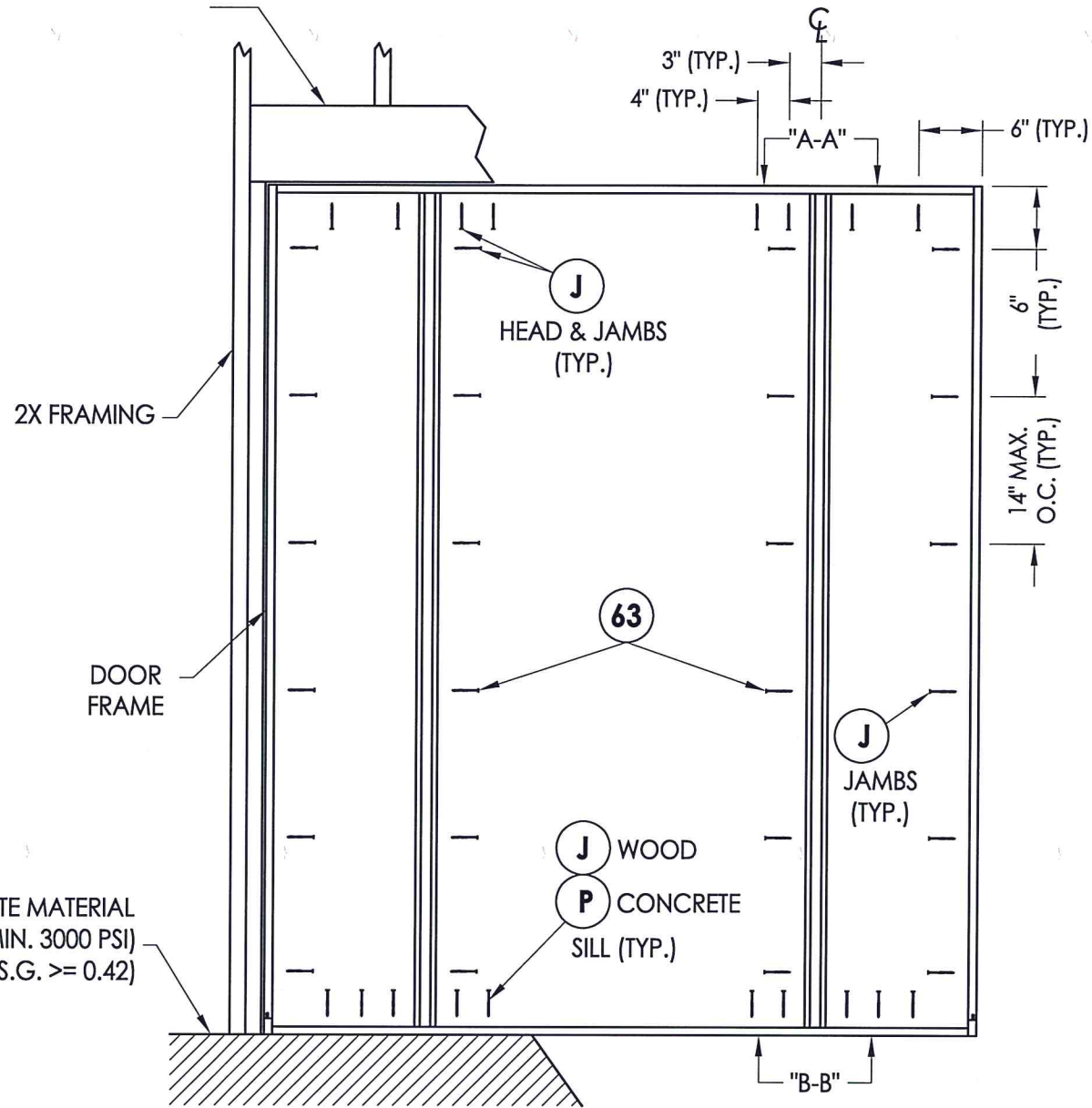

FRAME ANCHORING
Stud construction

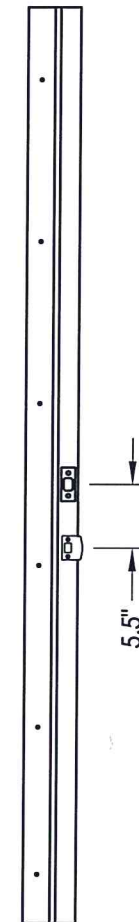

STRIKE JAMB

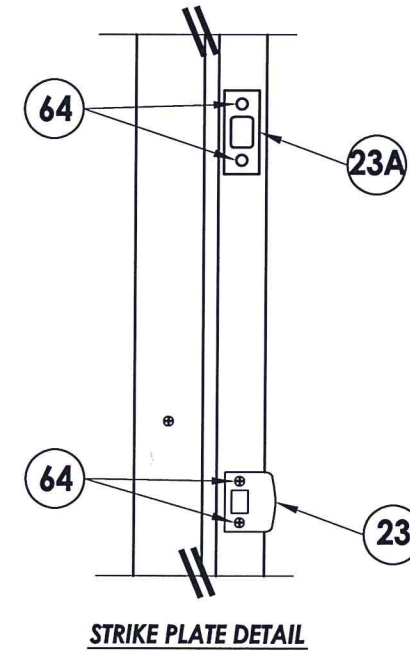

STRIKE PLATE DETAIL

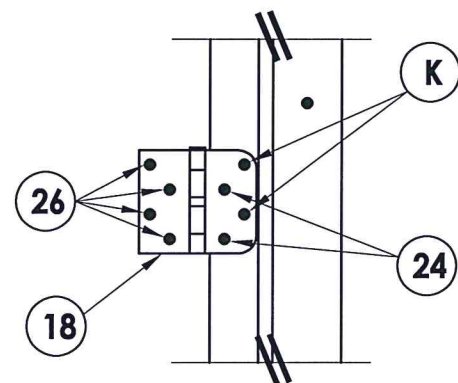

HINGE DETAIL 1

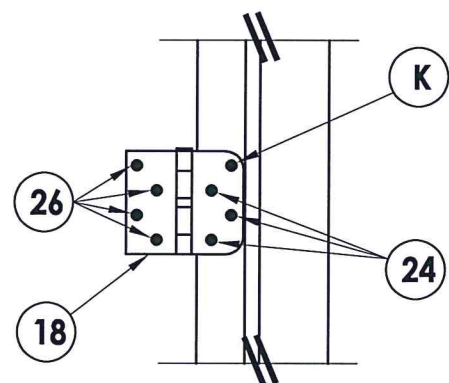

HINGE DETAIL 2

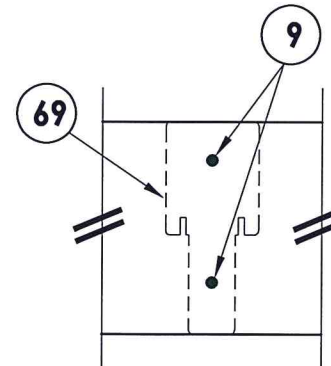

VIEW A-A

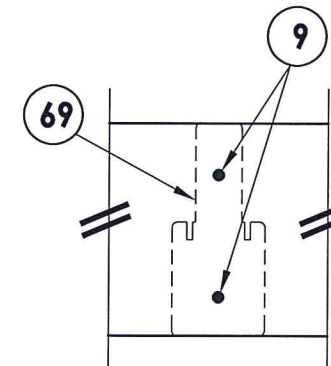

VIEW B-B

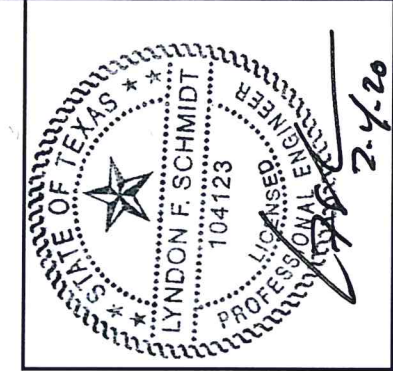

Documents Prepared By: Lyndon F. Schmidt, P.E.
TEXAS P.E. #104123

RW BUILDING CONSULTANTS, INC.
P.O. Box 230 Valrico FL 33595
Phone No.: 813.659.9197

TEXAS BOARD OF PROFESSIONAL ENGINEERS
CERTIFICATE OF REGISTRATION # F-11852

PRODUCT:	TRINITY GLASS INT'L 6 8 FLUSH GLAZED
PART OR ASSEMBLY:	FRAME ANCHORING

NO.	DATE	REVISIONS
3	2/03/20	UPDATE TO 2018 IBC/IRC
2	7/27/09	TDI PRODUCT EVALUATION UPDATE
1	6/28/06	REVISED LOCKSET NOMENCLATURE
		EW
		BY

DATE:	8/29/05
SCALE:	N.T.S.
DWG. BY:	WH
CHK. BY:	LFS
DRAWING NO.:	TX-4036
SHEET	7 of 9

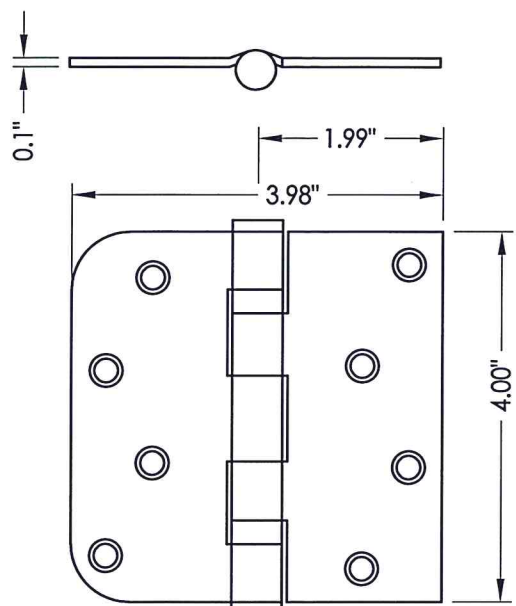

18 HINGE

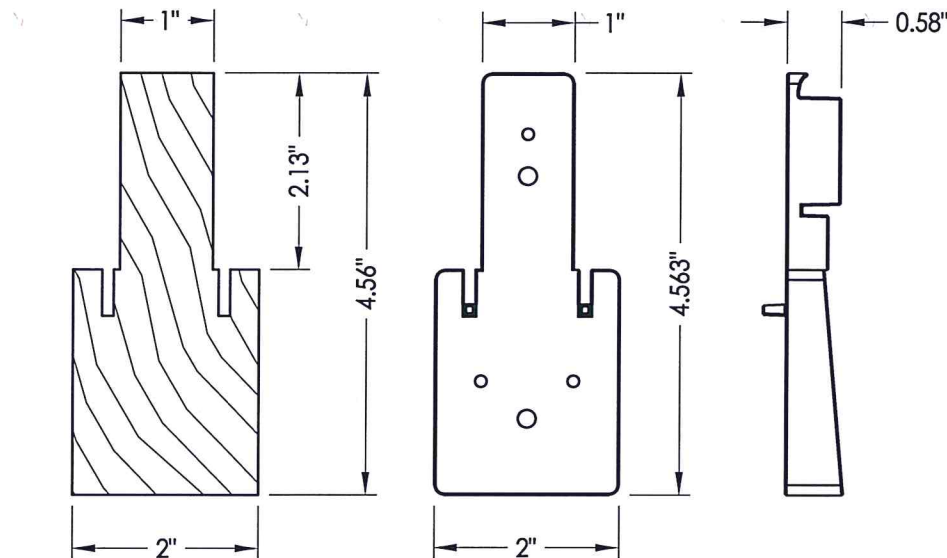

67 INTEGRAL MULLION

69 MULLION BASE KIT
Optional

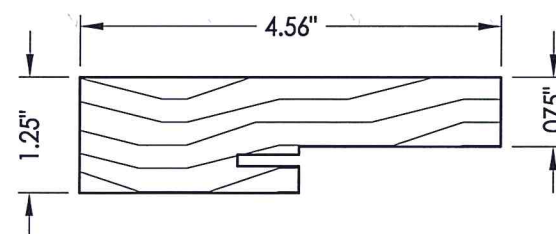

4 3 2 SIDE & HEAD JAMBS

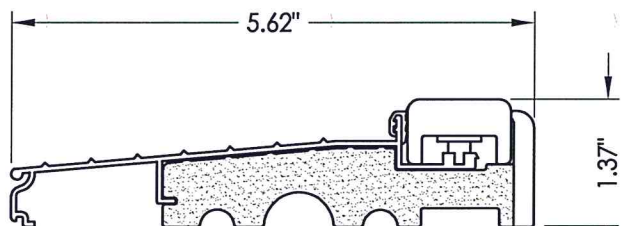

5 INSWING THRESHOLD

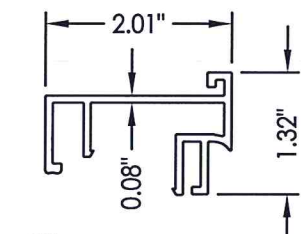

61 SIDELITE SPACER
Inswing

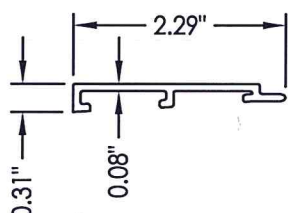

60 SIDELITE SPACER
Outswing

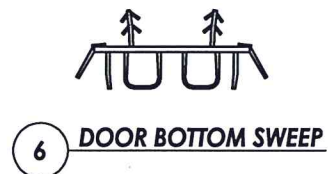

6 DOOR BOTTOM SWEEP

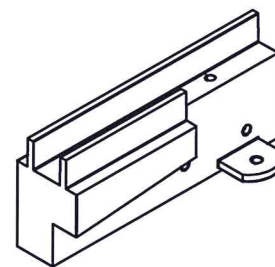

SILLKEY, LEFT
SCALE: NONE



SILLKEY, RIGHT
SCALE: NONE

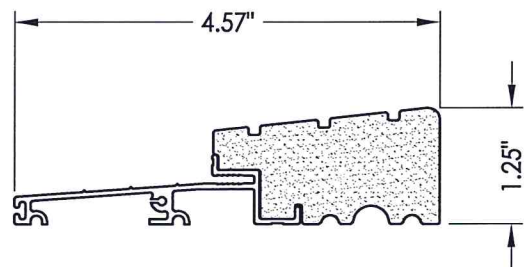

25 OUTSWING THRESHOLD
High-dam option

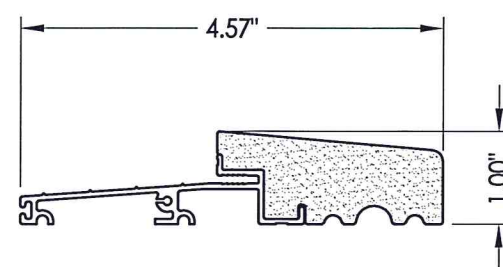

27 OUTSWING THRESHOLD

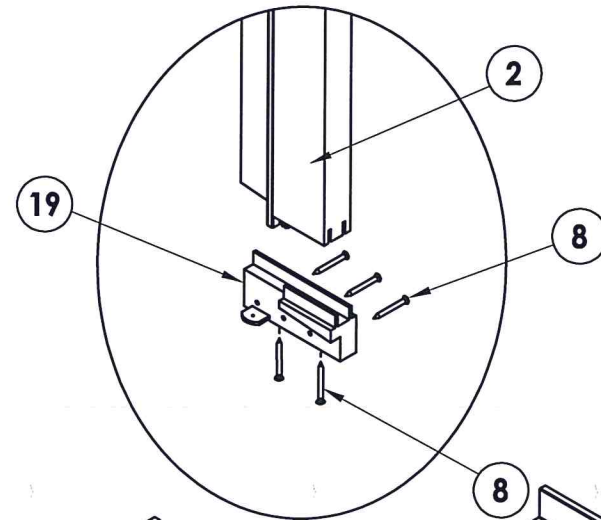

19 SILLKEY DETAILS
Optional



Documents Prepared By: Lyndon F. Schmidt, P.E.
TEXAS P.E. #104123

RW BUILDING CONSULTANTS, INC.
P.O. Box 230 Valrico FL 33595
Phone No.: 813.659.9197

TEXAS BOARD OF PROFESSIONAL ENGINEERS
CERTIFICATE OF REGISTRATION # F-11852

PRODUCT: TRINITY GLASS INT'L
6 8 FLUSH GLAZED

PART OR ASSEMBLY: COMPONENTS

NO.	DATE	REVISIONS
3	2/03/20	UPDATE TO 2018 IBC/IRC
2	7/27/09	TDI PRODUCT EVALUATION UPDATE
1	6/28/06	REVISED LOCKSET NOMENCLATURE
		EW
		BY

DATE: 8/29/05
SCALE: N.T.S.
DWG. BY: WH
CHK. BY: LFS
DRAWING NO.: TX-4036
SHEET 8 of 9

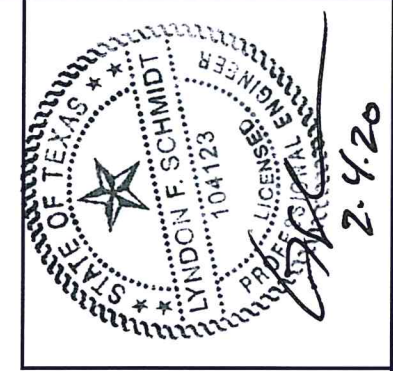

Documents Prepared By: Lyndon F. Schmidt, P.E.
TEXAS P.E. #104123

RW BUILDING CONSULTANTS, INC.
P.O. Box 230 Valrico FL 33595
Phone No.: 813.659.9197

TEXAS BOARD OF PROFESSIONAL ENGINEERS
CERTIFICATE OF REGISTRATION # F-11852

BILL OF MATERIALS

ITEM	DESCRIPTION	MATERIAL	ITEM	DESCRIPTION	MATERIAL
A	2X HEADER FRAMING SG >= 0.42	WOOD	27	OUTSWING THRESHOLD ALUMINUM W/ COMPOSITE SUBSTRATE	ALUM./ COMP.
B	2X FRAMING SG >= 0.42	WOOD	30	LATCH STILE - SG >= 0.42	LVL/PVC
G	MAX. 1/4" SHIM SPACE	WOOD	31	LVL LOCK BLOCK	POPLAR
J	#10 X 3" PFH WS	STEEL	32	HINGE STILE - SG >= 0.42	LVL/PVC
K	#9 X 2" PFH WS	STEEL	33	TOP RAIL - POPLAR LVL & WPC COMBINATION	POPLAR/WPC
P	3/16" X 2-3/4" ELCO OR ITW PFH CONCRETE SCREW	STEEL	34	BOTTOM RAIL - POPLAR LVL & WPC COMBINATION	POPLAR/WPC
2	STRIKE JAMB - FINGER-JOINT PINE - SG >= 0.42	WOOD	35	LITE FRAME	PC/ASA
3	HINGE JAMB - FINGER-JOINT PINE - SG >= 0.42	WOOD	36	GLAZING COMPOUND	SILICONE
4	HEAD - FINGER-JOINT PINE - SG >= 0.42	WOOD	39	FIBERGLASS SKIN 0.079" MIN. THICKNESS	FIBERGLASS
5	INSWING THRESHOLD ALUMINUM W/ COMPOSITE SUBSTRATE	ALUMINUM	40	#8 X 1-1/8" SELF THREADING SCREW	STEEL
6	DOOR BOTTOM SWEEP	PVC	41	POLYPROPYLENE & PVC COMBINATION GLAZING SPACER	POLY.
7	DOOR PANEL - SEE DOOR PANEL DETAIL SHEET FOR CONSTRUCTION DETAILS	-	42	ALUMINUM & BUTYL SPACER SYSTEM	ALUM./BUTYL
8	#6 X 1-1/4 PFH DRYWALL SCREW	STEEL	43	PVC & ALUMINUM SPACER SYSTEM	PVC/ ALUM.
9	#9 X 2-1/4" PFH WOOD SCREW	STEEL	60	SIDELITE SPACER - OUTSWING	PVC
12	WEATHER STRIP QEBD650 Q-LON	-	61	SIDELITE SPACER - INSWING	PVC
18	3.983" X 4.0" HINGE MIN 0.098" THICK	STEEL	62	QUARTER ROUND	WOOD
19	SILLKEY	PC/ASA	63	#8 X 2-1/4" PFH SCREW	STEEL
21	LOCK (SEE LOCK & DEADBOLT RATINGS CHART)	STEEL	64	#8 X 2" PFH SCREW	STEEL
22	DEADBOLT (SEE LOCK & DEADBOLT RATINGS CHART)	STEEL	66	SIDELITE PANEL - SEE SIDELITE PANEL DETAIL SHEET FOR CONSTRUCTION DETAILS	-
23	STRIKE PLATE	STEEL	67	INTEGRAL MULLION - FINGER JOINT PINE (SG >= 0.42)	WOOD
23A	DEADBOLT PLATE	STEEL	69	MULLION BASE KIT	PC/ASA
24	#9 X 5/8" PFH WS	STEEL	70	LVL SIDELITE STILE	POPLAR
25	OUTSWING HIGH-DAM THRESHOLD ALUMINUM W/ COMPOSITE SUBSTRATE	ALUM./ COMP.	71	LVL SIDELITE TOP RAIL	POPLAR
26	#9 X 1" PFH WS	STEEL	72	LVL SIDELITE BOTTOM RAIL	POPLAR

CONCRETE ANCHOR NOTES:

- Concrete anchor locations at the corners may be adjusted to maintain the min. edge distance to mortar joints.
- Concrete anchor locations noted as "MAX. ON CENTER" must be adjusted to maintain the min. edge distance to mortar joints, additional concrete anchors may be required to ensure the "MAX. ON CENTER" dimension are not exceeded.
- Concrete anchor table:

ANCHOR TYPE	ANCHOR SIZE	MIN. EMBEDMENT	MIN. CLEARANCE TO MASONRY EDGE	MIN. CLEARANCE TO ADJACENT ANCHOR
ITW BUILDEX TAPCON®	1/4"	1-3/4"	2"	4"
ELCO ULTRACON®	1/4"	1-3/4"	1"	4"

WOOD SCREW INSTALLATION NOTES:

- Maintain a minimum 5/8" edge distance, 1" end distance, & 1" o.c. spacing of wood screws to prevent the splitting of wood.

PRODUCT: TRINITY GLASS INT'L
6'8 FLUSH GLAZED

PART OR ASSEMBLY:
BILL OF MATERIALS & COMPONENTS

NO.	DATE	REVISIONS
3	2/03/20	UPDATE TO 2018 IBC/IRC
2	7/27/09	TDI PRODUCT EVALUATION
1	6/28/06	REVISED LOCKSET NOMENCLATURE
		BY

DATE: 8/29/05
SCALE: N.T.S.
DWG. BY: WH
CHK. BY: LFS
DRAWING NO.: TX-4036
SHEET 9 OF 9