

GLAZED FIBERGLASS SINGLE DOOR w/ or w/out SIDELITE(S) "IMPACT" INSWING / OUTSWING

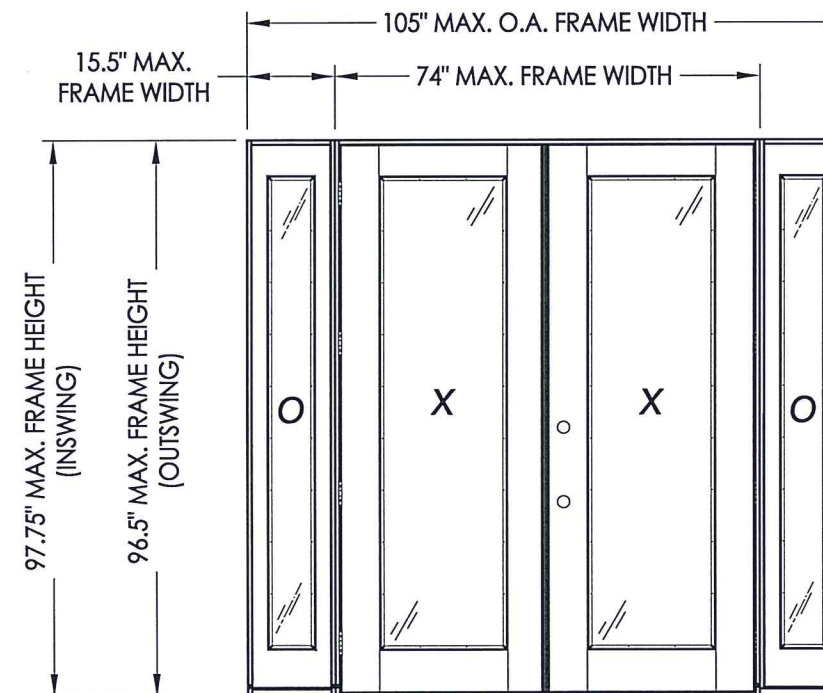
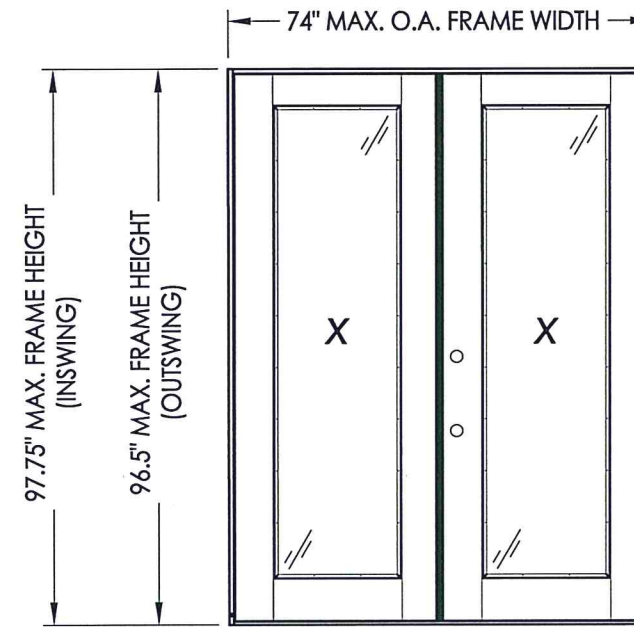

EVALUATED FOR USE IN THE STATE OF TEXAS

The Fiberglass Door system described herein complies with the 2018 International Residential Code (IRC), Sections R301 & R609 and the 2018 International Building Code (IBC), Sections 1404.13, 1609, 1709.5, 2403 and 2404 subject to the following conditions:

1. Anchors shall be as listed and spaced as shown in the details. Anchor embedment to base material shall be beyond wall dressing or stucco.
2. This system has been tested and evaluated as a large missile impact protective system for installation in areas that require wind borne debris protection. This product meets missile level "D" as defined in ASTM E 1996.
3. Allowable design pressure requirements must be equal to or less than the design pressure rating shown in the design pressure chart, sheet 1 of this drawing.
4. Conditions not covered by this drawing are subject to further engineering analysis.

TABLE OF CONTENTS

SHEET #	DESCRIPTION
1	Typical elevations, design pressures & general notes
2	Door panel details
3	Sidelite panel details
4	Elevations
5	Horizontal & vertical cross sections
6	Horizontal cross sections
7	Vertical cross sections
8	Frame anchoring
9	Components
10	Bill of materials

CONFIGURATION	DESIGN PRESSURE (PSF) INSWING		DESIGN PRESSURE (PSF) OUTSWING	
	POSITIVE	NEGATIVE	POSITIVE	NEGATIVE
XX, OXXO	+40.0	-45.0	+45.0	-45.0



Documents Prepared By: Lyndon F. Schmidt, P.E.
TEXAS P.E. #104123

RW BUILDING CONSULTANTS, INC.
P.O. Box 230 Valrico FL 33595
Phone No.: 813.659.9197

CERTIFICATE OF REGISTRATION # F-11852

PRODUCT: TRINITY GLASS INT'L

PART OR ASSEMBLY: TYPICAL ELEVATION, DESIGN PRESSURES & GENERAL NOTES

NO.	DATE	BY	REVISIONS

DATE: 4/15/21
SCALE: N.T.S.
DWG. BY: RW
CHK. BY: LFS
DRAWING NO.: TX-5173
SHEET 1 OF 10

Z:\Clients\Trinity Glass Permanent\B - Texas Dept of Ins\DR-XXX 8-0 GLZ FG - IMP\C - Drawings\TX-5172-74.dwg

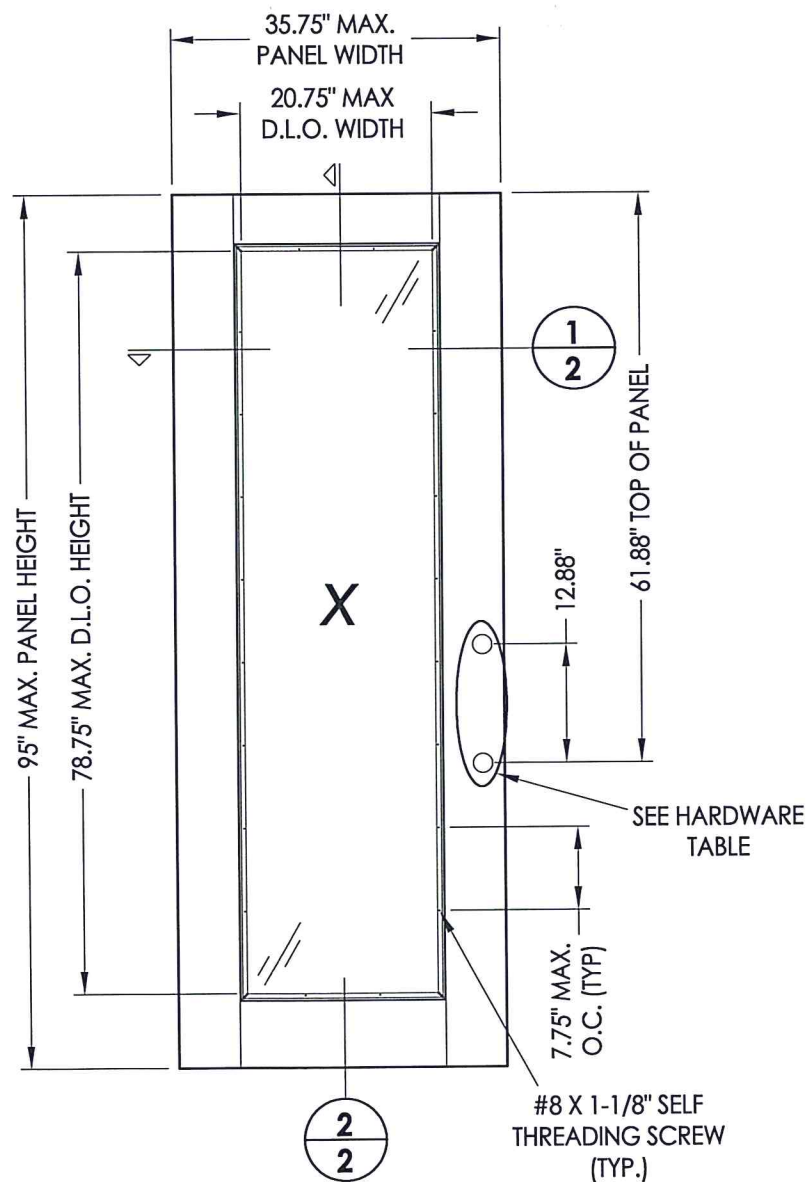
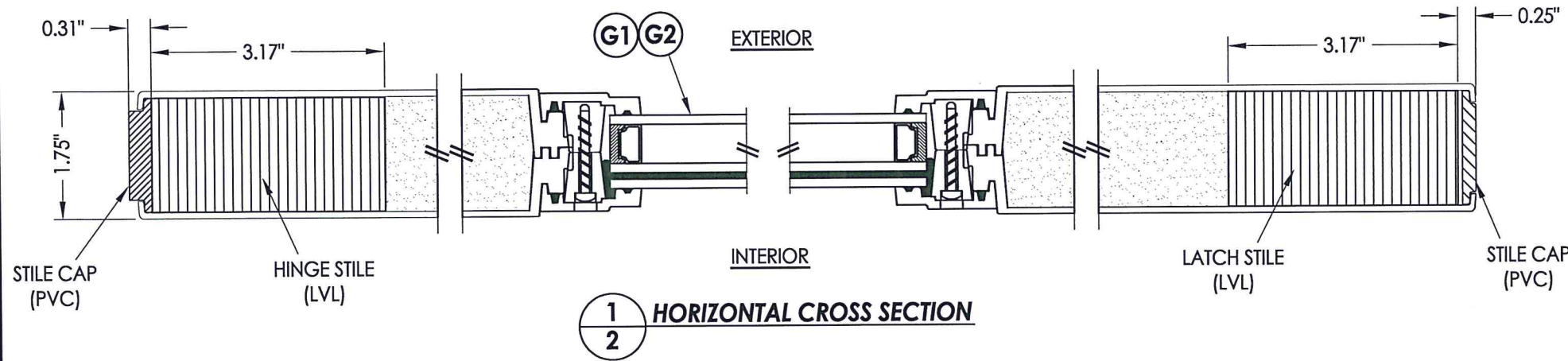

HARDWARE CHART	
MANUFACTURER	MODEL
KWIKSET	KNOB: SIGNATURE SERIES
	DEADBOLT: SIGNATURE SERIES (980)
SCHLAGE	KNOB: F SERIES
	DEADBOLT: B60 SERIES

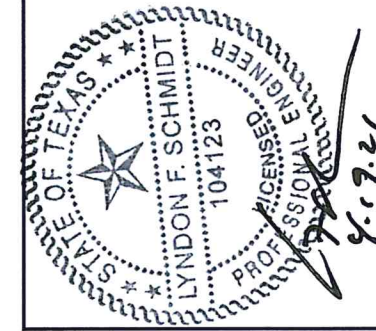
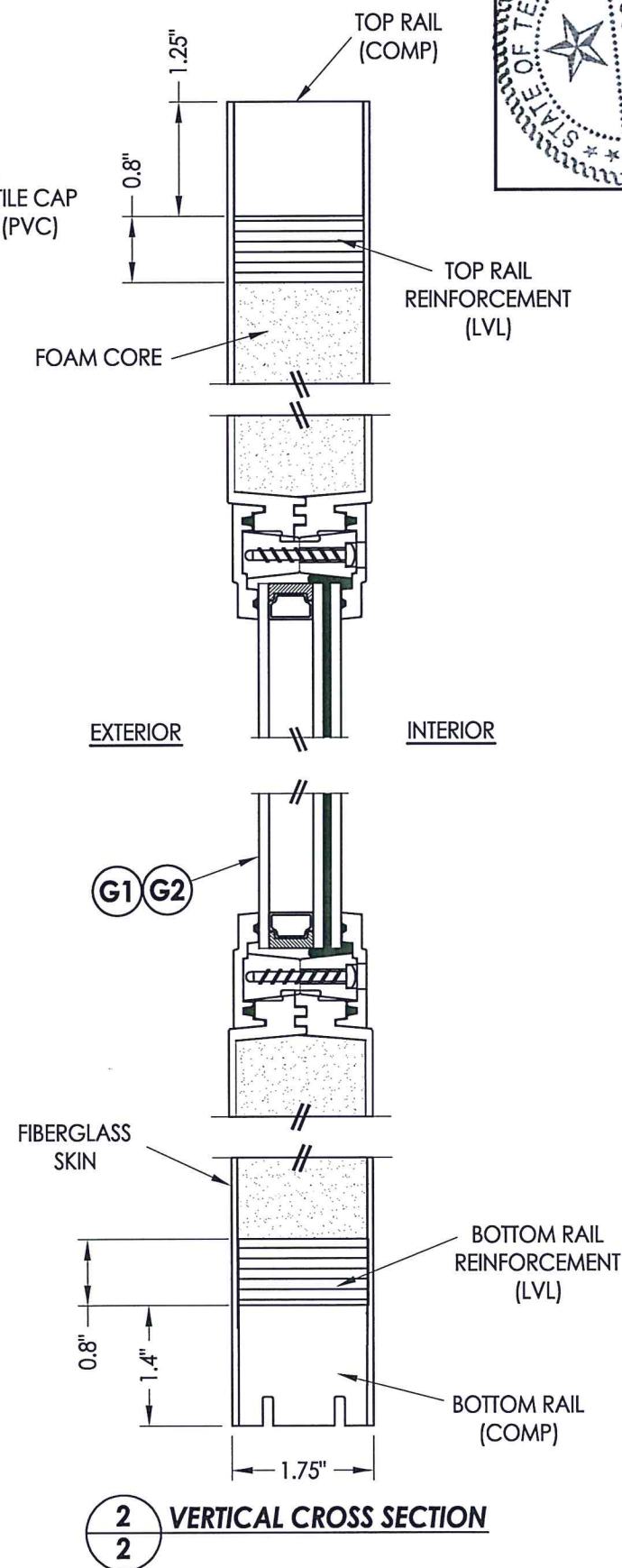

Documents Prepared By: Lyndon F. Schmidt, P.E.
TEXAS P.E. #104123

RW BUILDING CONSULTANTS, INC.
P.O. Box 230 Valrico FL 33595
Phone No.: 813.659.9197

CERTIFICATE OF REGISTRATION # F-11852

PRODUCT:	TRINITY GLASS INT'L
PART OR ASSEMBLY:	DOOR PANEL DETAILS
NO.	DATE
BY	REVISIONS
DATE:	4/15/21
SCALE:	N.T.S.
DWG. BY:	RW
CHK. BY:	LFS
DRAWING NO.:	TX-5173
SHEET	2 OF 10

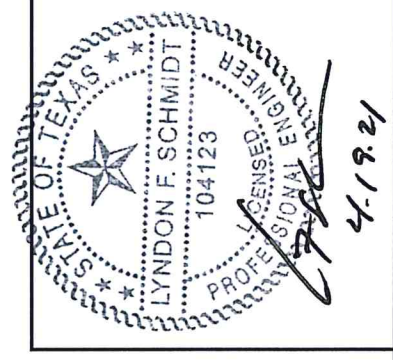
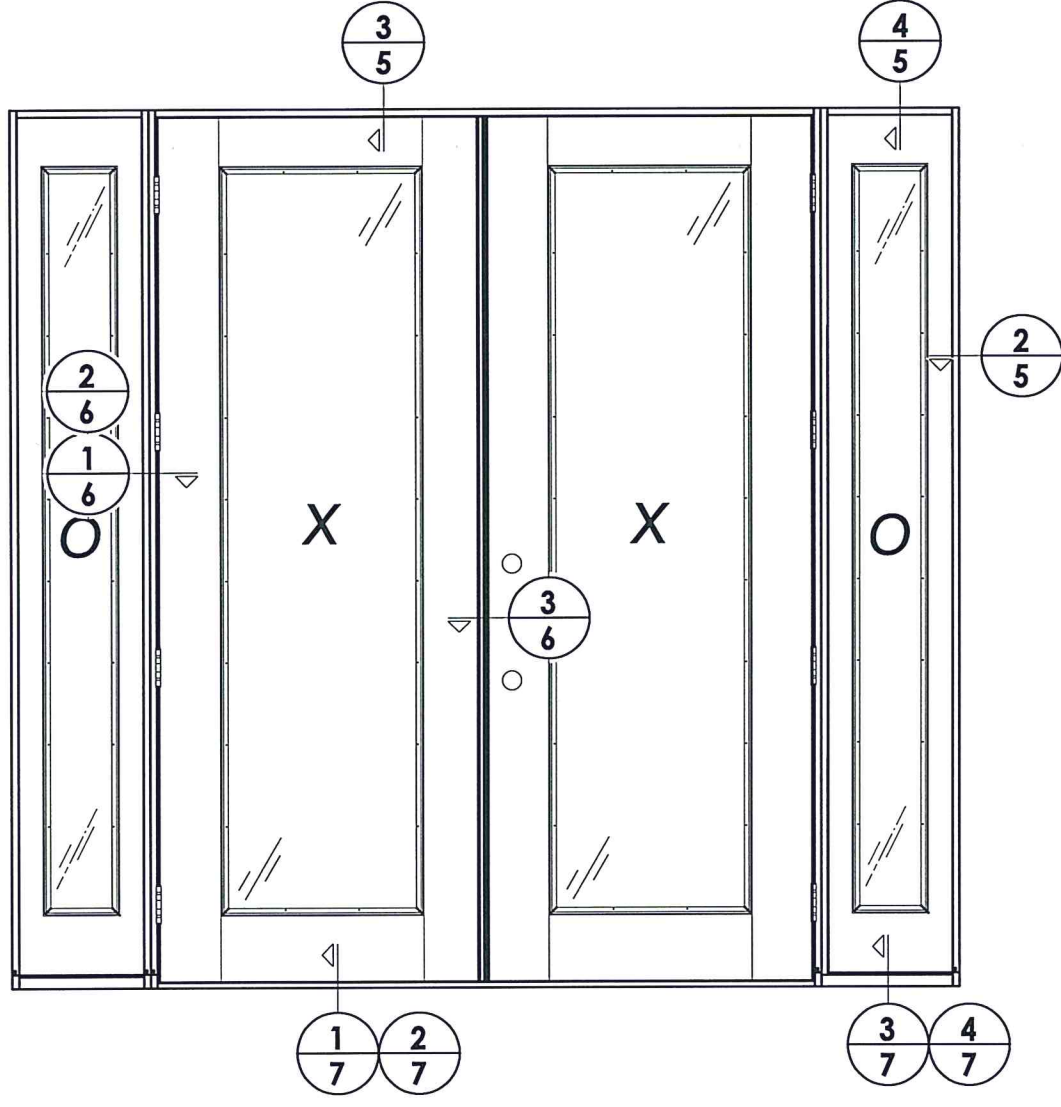
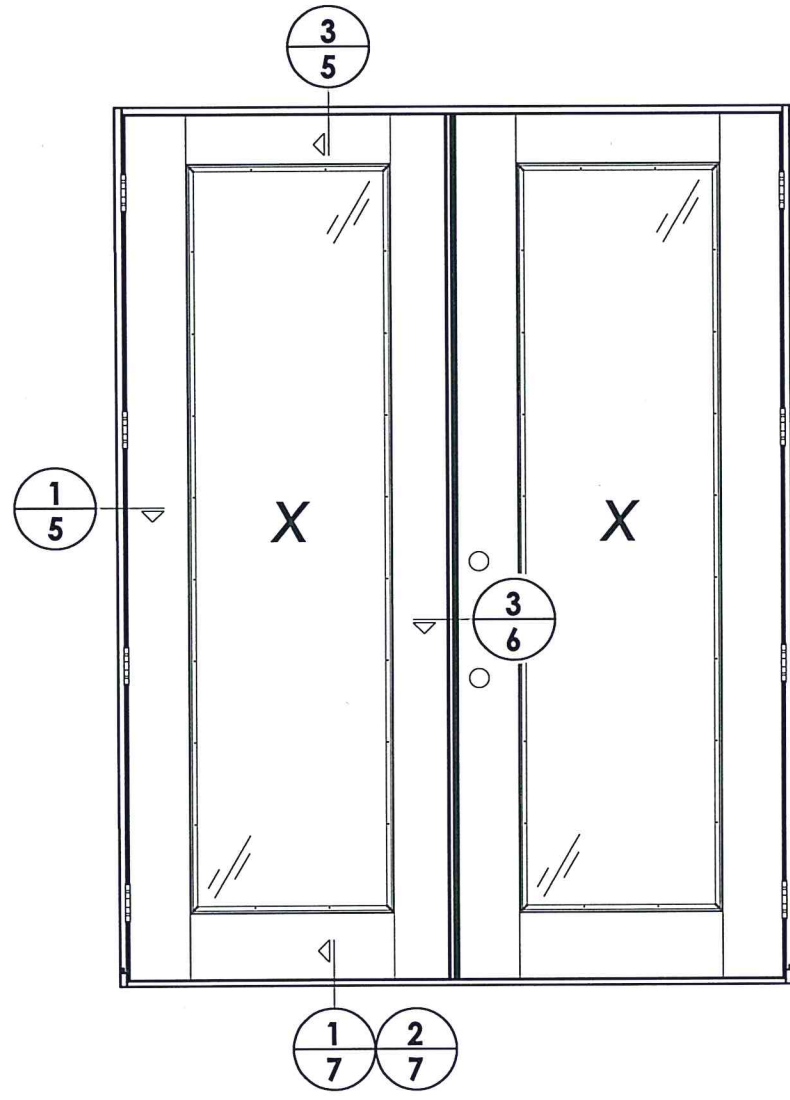

Documents Prepared By: Lyndon F. Schmidt, P.E.
 TEXAS P.E. #104123

RW BUILDING CONSULTANTS, INC.
 P.O. Box 230 Valrico FL 33595
 Phone No.: 813.659.9197

CERTIFICATE OF REGISTRATION # F-11852

PRODUCT: TRINITY GLASS INT'L

PART OR ASSEMBLY: ELEVATIONS

NO.	DATE	BY

DATE: 4/15/21
 SCALE: N.T.S.
 DWG. BY: RW
 CHK. BY: LFS
 DRAWING NO.: TX-5173
 SHEET 4 OF 10

Z:\Clients\Trinity Glass Permanent\B - Texas Dept of Ins\DR-XXX 8-0 GLZ FG - IMP\C - Drawings\TX-5172-74.dwg

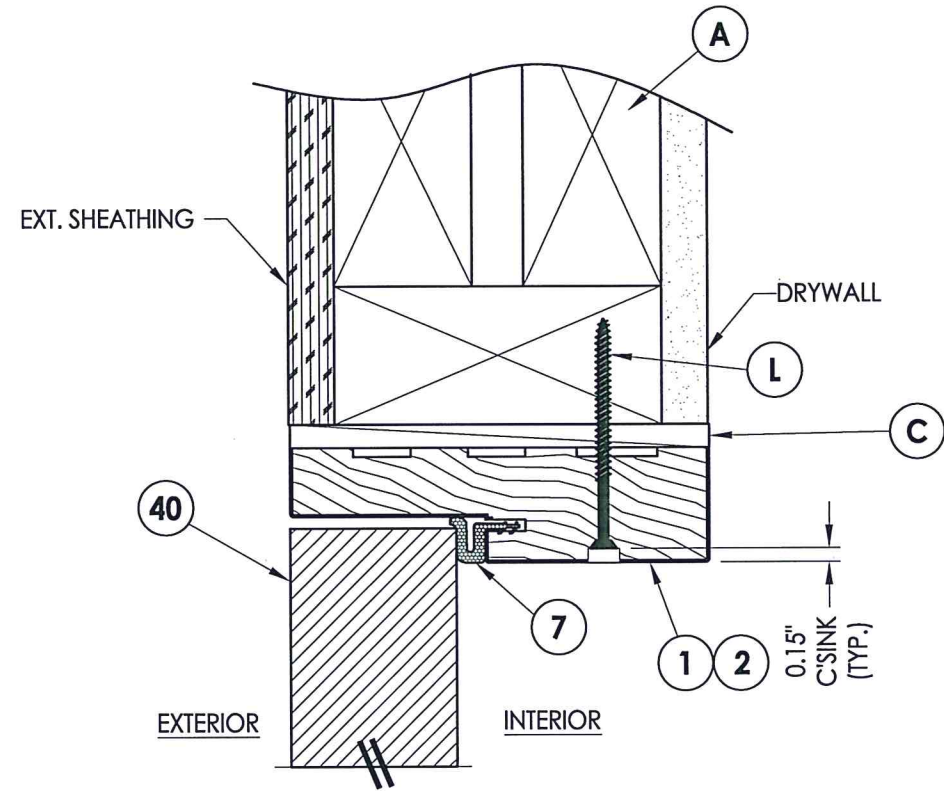

3 VERTICAL CROSS SECTION
5 Outswing shown (Inswing similar)

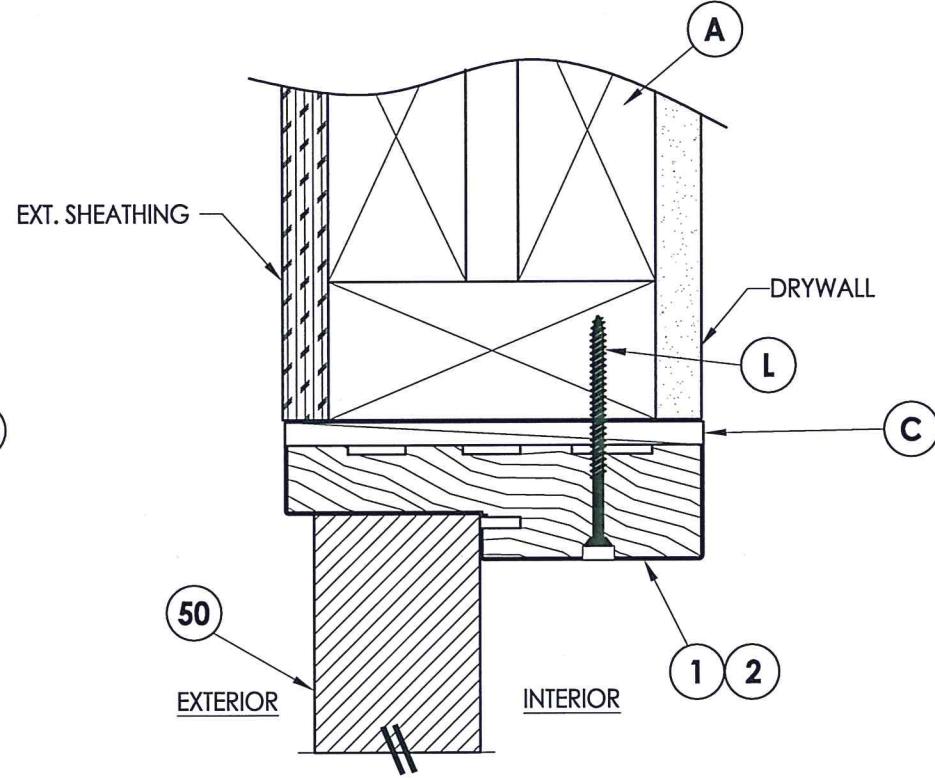

4 VERTICAL CROSS SECTION
5 Outswing shown (Inswing similar)

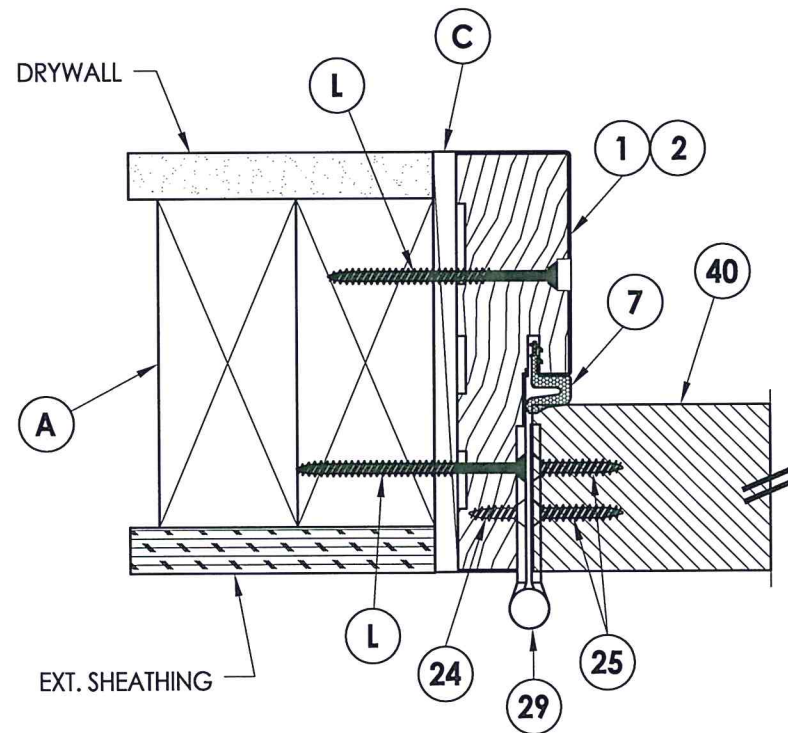

1 HORIZONTAL CROSS SECTION
5 Outswing shown (Inswing similar)

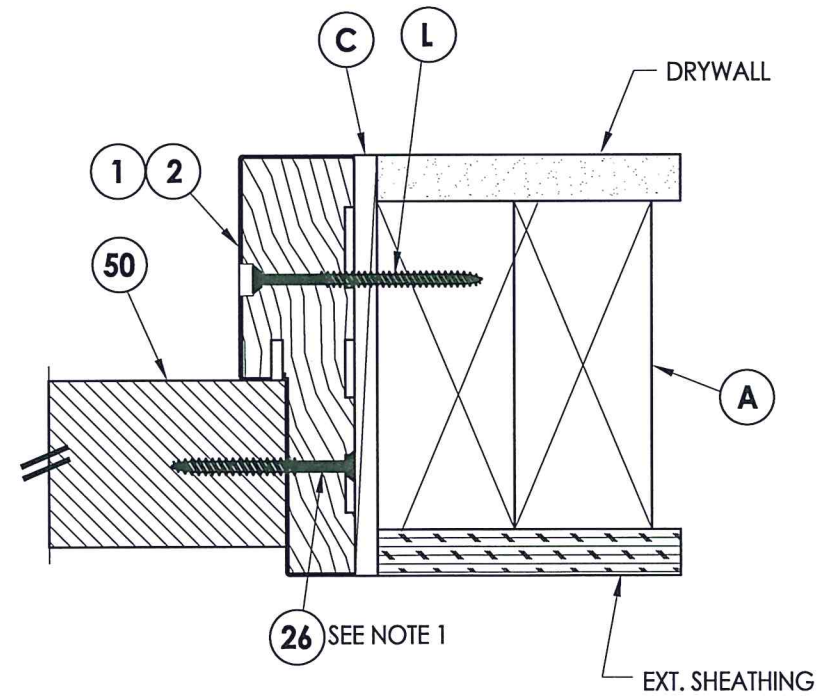

2 HORIZONTAL CROSS SECTION
5 Outswing shown (Inswing similar)

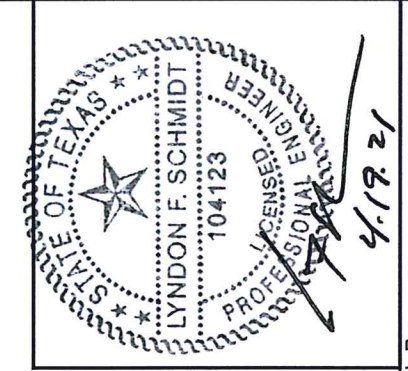

NOTES:
 1. Item #26 located 6" from each end and 3 more equally spaced (5 total).

Documents Prepared By: Lyndon F. Schmidt, P.E.
 TEXAS P.E. #104123
 R.W. BUILDING CONSULTANTS, INC.
 P.O. Box 230 Valrico FL 33595
 Phone No.: 813.659.9197
 CERTIFICATE OF REGISTRATION # F-11852

PRODUCT:	TRINITY GLASS INT'L	
PART OR ASSEMBLY:	HORIZONTAL & VERTICAL CROSS SECTIONS	
NO.	DATE	BY
		REVISIONS
DATE:	4/15/21	
SCALE:	N.T.S.	
DWG. BY:	RW	
CHK. BY:	LFS	
DRAWING NO.:	TX-5173	
SHEET	5	OF 10

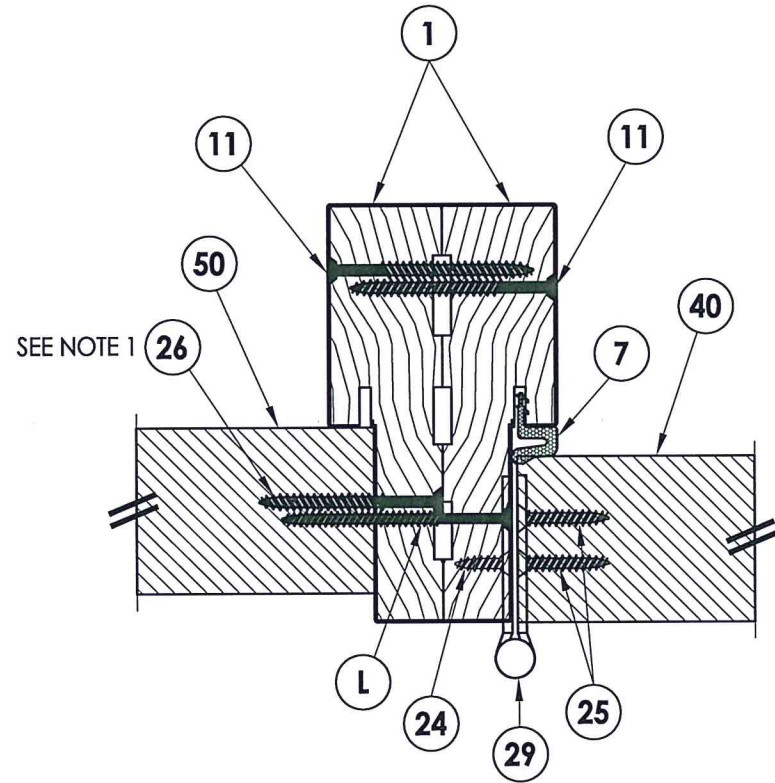

1 **HORIZONTAL CROSS SECTION**
6 Outswing shown - Inswing also approved

NOTE:
 1. Item #26 located 6" from each end plus 5 more equally spaced (7 total).

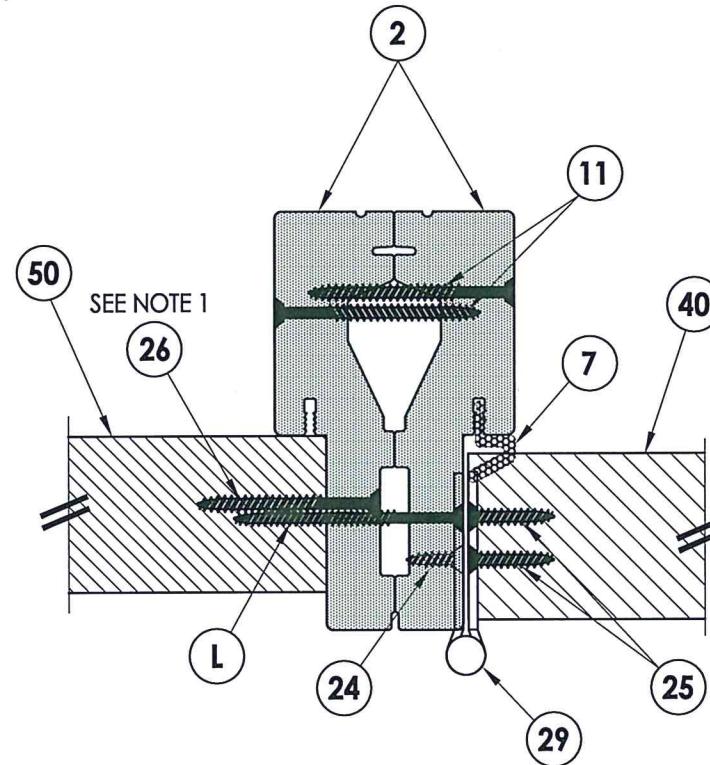

2 **HORIZONTAL CROSS SECTION**
6 Outswing shown - Inswing also approved

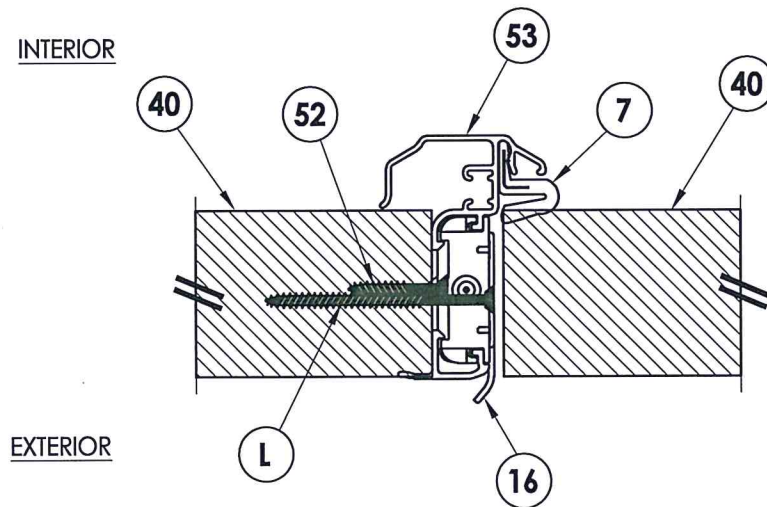

3 **HORIZONTAL CROSS SECTION**
6 Outswing shown - Inswing also approved

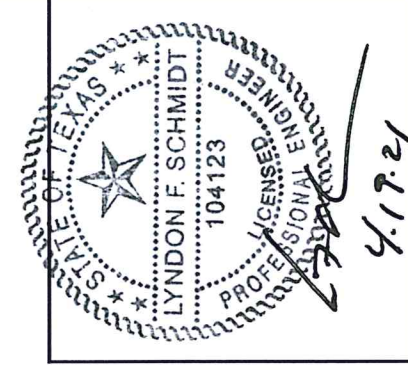

Documents Prepared By: Lyndon F. Schmidt, P.E.
 TEXAS P.E. #104123

RW BUILDING CONSULTANTS, INC.
 P.O. Box 230 Valrico FL 33595
 Phone No.: 813.659.9197

CERTIFICATE OF REGISTRATION # F-11852

PRODUCT: TRINITY GLASS INT'L	
PART OR ASSEMBLY: HORIZONTAL CROSS SECTIONS	
NO.	DATE
BY	REVISIONS
DATE: 4/15/21	
SCALE: N.T.S.	
DWG. BY: RW	
CHK. BY: LFS	
DRAWING NO.: TX-5173	
SHEET 6 of 10	

Z:\Clients\Trinity Glass PERMANENT\B - Texas Dept of Ins\DR-XXX 8-0 GLZ FG - IMP\C - Drawings\TX-5172-74.dwg

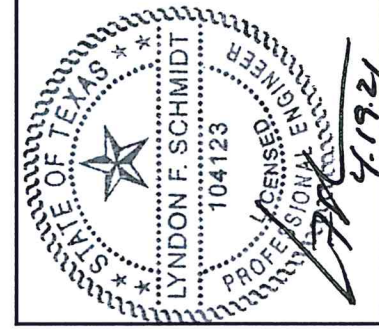
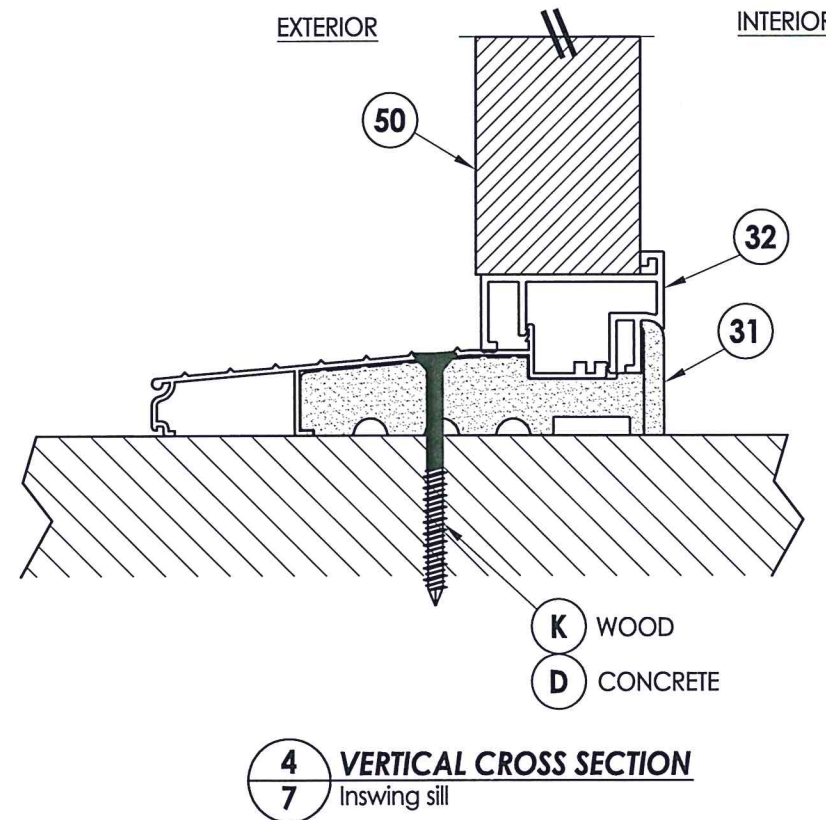
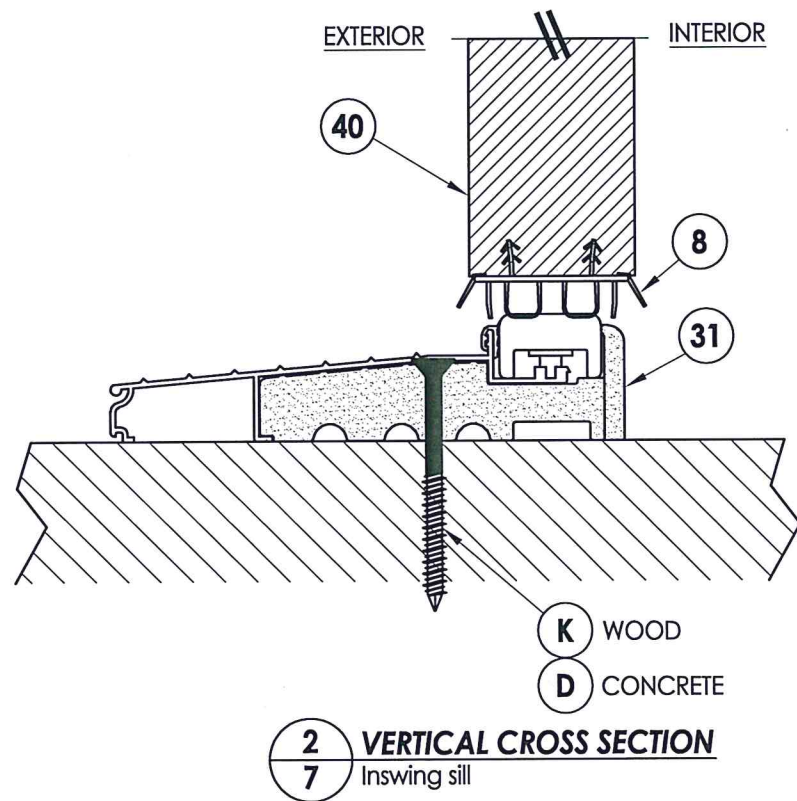
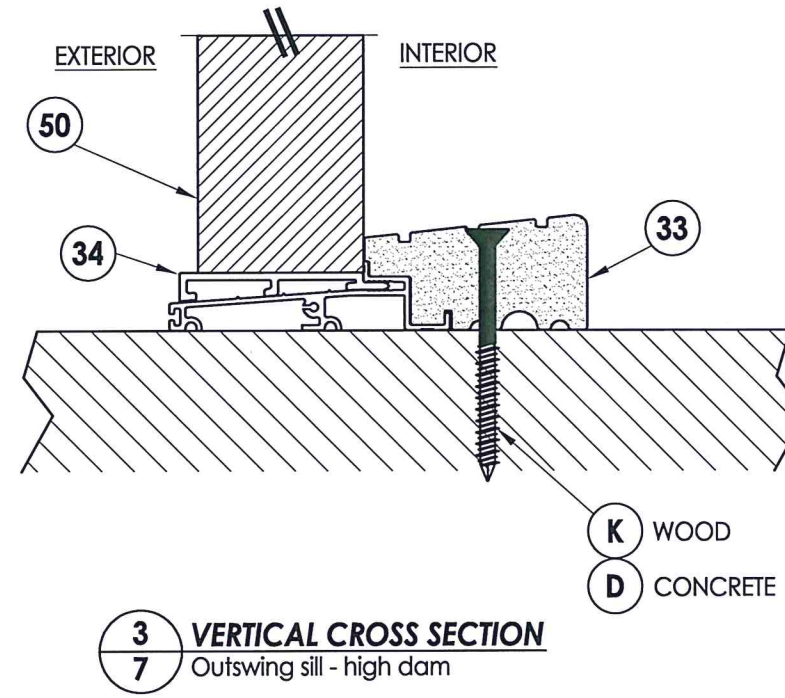
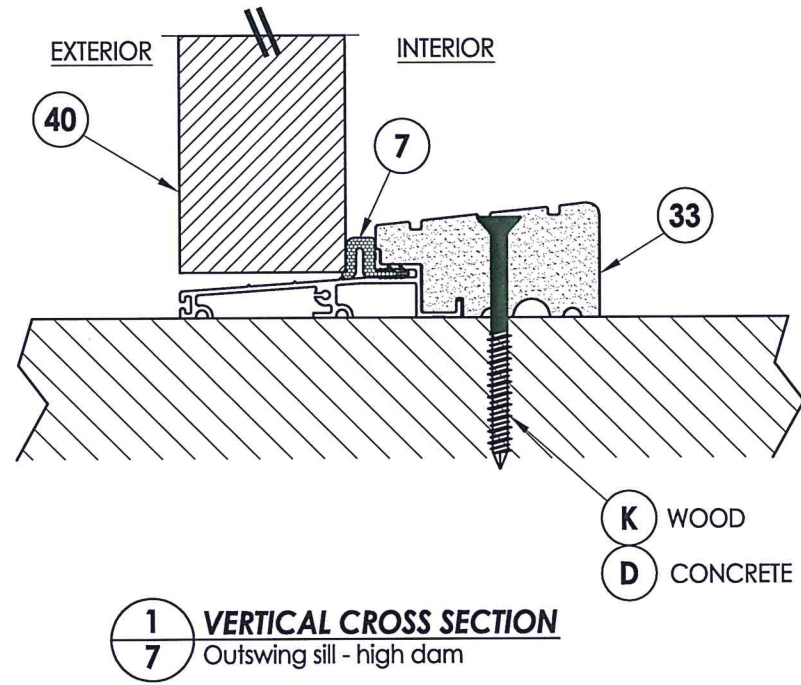

Documents Prepared By: Lyndon F. Schmidt, P.E.
TEXAS P.E. #104123

RW BUILDING CONSULTANTS, INC.
P.O. Box 230 Valrico FL 33595
Phone No.: 813.659.9197

CERTIFICATE OF REGISTRATION # F-11852

PRODUCT: TRINITY GLASS INT'L	
PART OR ASSEMBLY: VERTICAL CROSS SECTIONS	
NO.	DATE
BY	REVISIONS
DATE: 4/15/21	
SCALE: N.T.S.	
DWG. BY: RW	
CHK. BY: LFS	
DRAWING NO.: TX-5173	
SHEET 7 OF 10	

Z:\Clients\Trinity Glass Permanent\B - Texas Dept of Ins\DR-XXX 8-0 GLZ FG - IMP\C - Drawings\TX-5172-74.dwg

*NOTE: FRAME CORNERS ATTACHED w/ #8 X 2" COURSE THREAD DRYWALL SCREWS: (3) @ HEAD, (3) @ INSWING SILL & (2) @ OUTSWING SILL (TYP.).

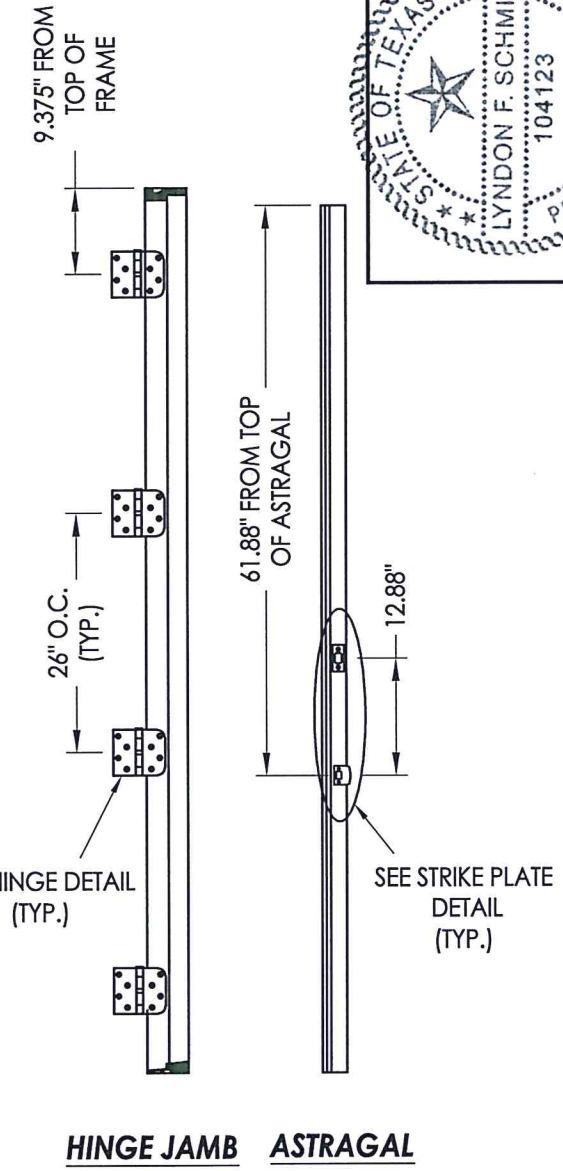
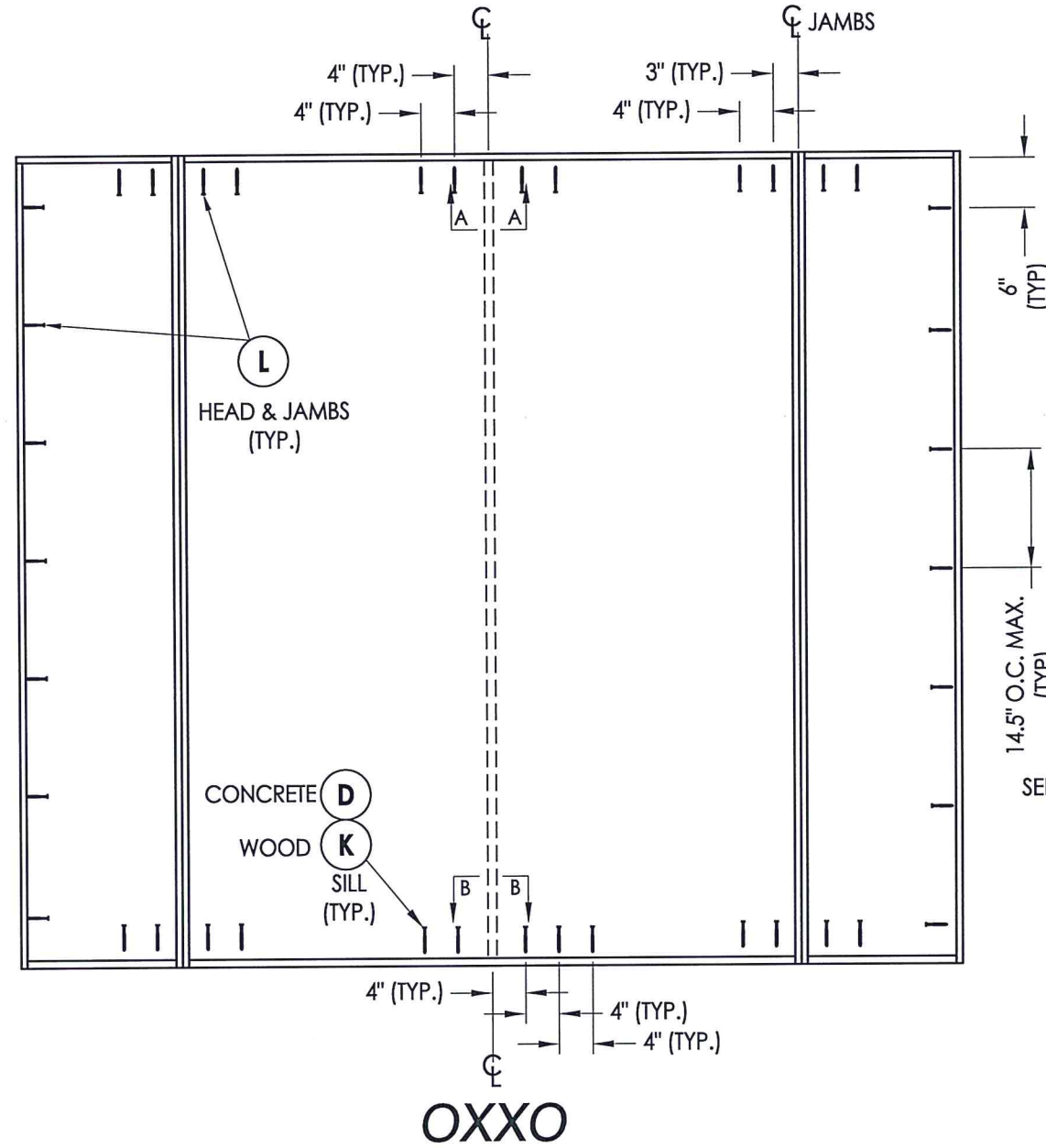
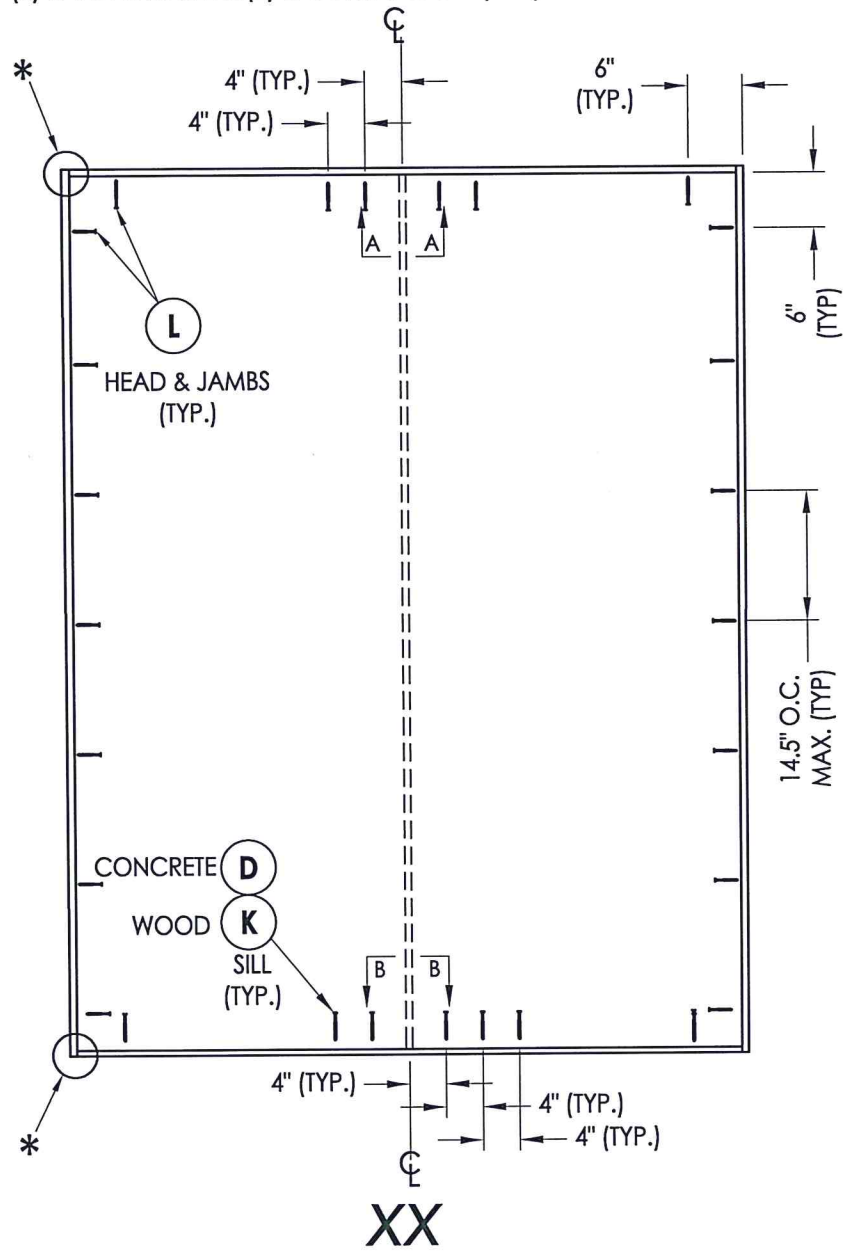

FRAME ANCHORING

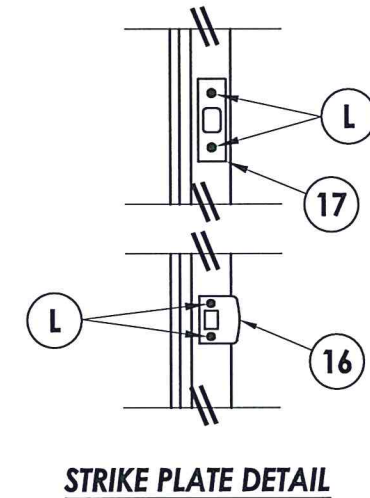
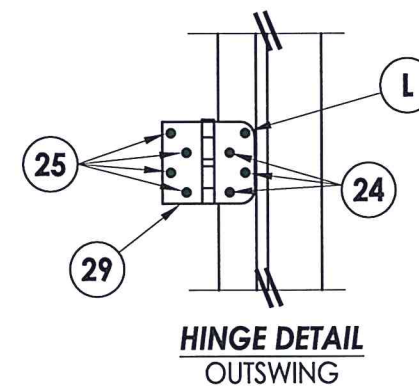
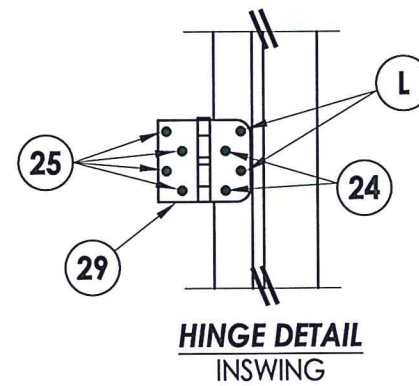
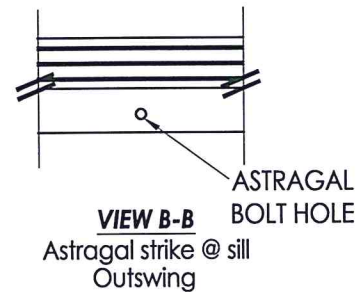
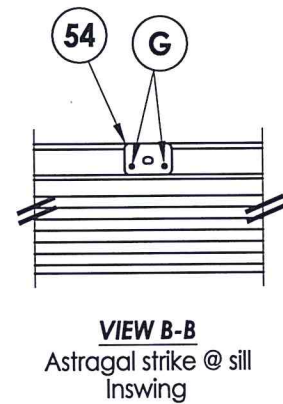
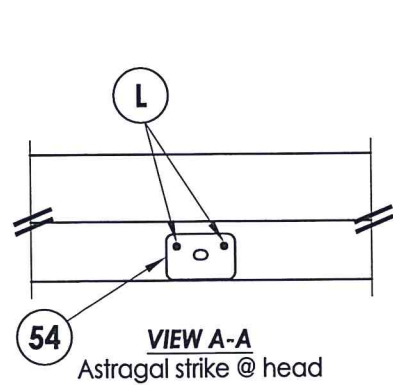

Documents Prepared By: Lyndon F. Schmidt, P.E.
TEXAS P.E. #104123

RW BUILDING CONSULTANTS, INC.
P.O. Box 230 Valrico FL, 33595
Phone No.: 813.659.9197

CERTIFICATE OF REGISTRATION # F-11852

PRODUCT: TRINITY GLASS INT'L

PART OR ASSEMBLY: FRAME ANCHORING

NO.	DATE	BY	REVISIONS

DATE: 4/15/21

SCALE: N.T.S.

DWG. BY: RW

CHK. BY: LFS

DRAWING NO.: TX-5173

SHEET 8 OF 10

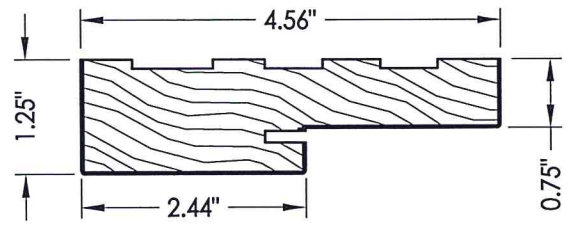

1 HEAD & JAMBS
FINGER JOINT PINE

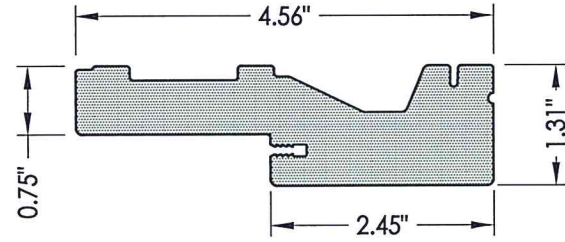

2 HEAD & JAMBS
PVC

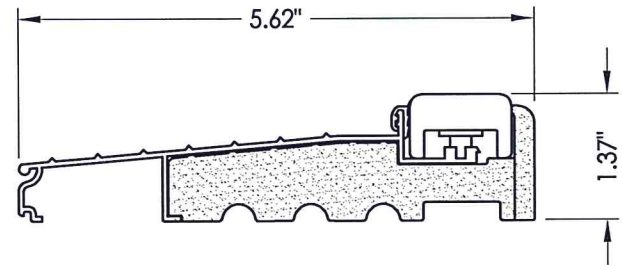

31 INSWING THRESHOLD

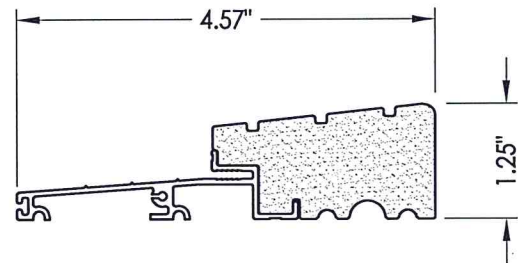

33 OUTSWING THRESHOLD
High-dam

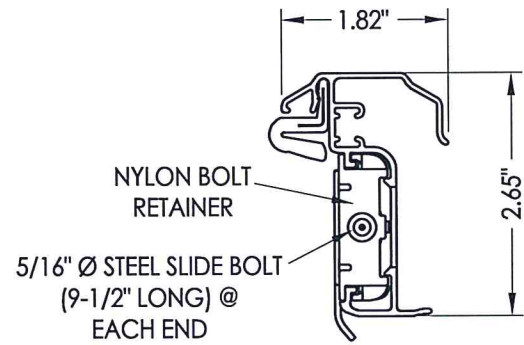

53 ULTIMATE HURRICANE ASTRAGAL
Endura Products

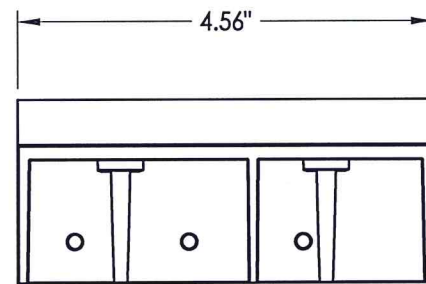

SILLKEY (LEFT)

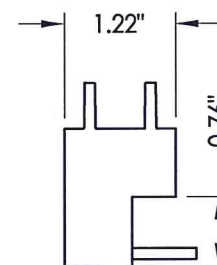

SILLKEY (RIGHT)

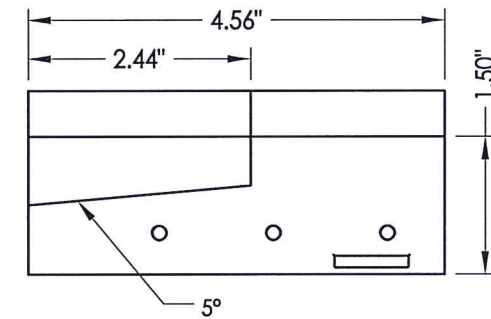

19 SILLKEY DETAILS
Optional

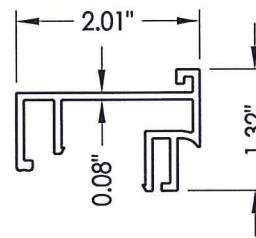

32 SIDELITE SPACER
Inswing

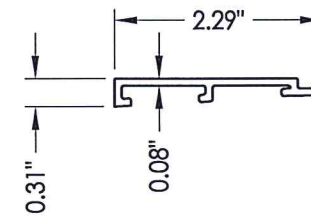

34 SIDELITE SPACER
Outswing

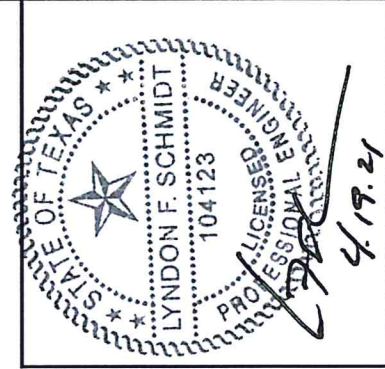
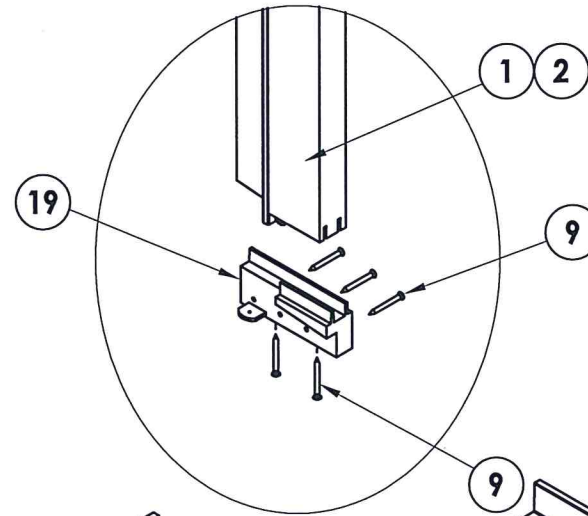

Documents Prepared By: Lyndon F. Schmidt, P.E.
TEXAS P.E. #104123

RW BUILDING CONSULTANTS, INC.
P.O. Box 230 Valrico FL 33595
Phone No.: 813.659.9197

CERTIFICATE OF REGISTRATION # F-11852

PRODUCT: TRINITY GLASS INT'L		REVISIONS	
PART OR ASSEMBLY: COMPONENTS		NO.	DATE
		BY	
DATE: 4/15/21			
SCALE: N.T.S.			
DWG. BY: RW			
CHK. BY: LFS			
DRAWING NO.: TX-5173			
SHEET 9 OF 10			

BILL OF MATERIALS		
ITEM #	DESCRIPTION	MATERIAL
A	2X FRAMING (SG >= 0.42)	WOOD
C	1/4" MAX. SHIM SPACE	-
D	1/4" FH DeWALT OR ITW CONCRETE SCREW (1-3/4" MIN. EMBEDMENT)	STEEL
K	#10 FH WOOD SCREW (1-3/4" MIN. EMBEDMENT)	STEEL
L	#10 X 2-1/2" PFH WS (1.15" MIN. EMBEDMENT)	STEEL
1	HEAD & JAMB (FINGER JOINT PINE: SG >= 0.42)	WOOD
2	HEAD & JAMB	PVC
7	WEATHERSTRIP	FOAM
8	DOOR BOTTOM SWEEP	PVC
9	#6 X 1-1/4 PFH DRYWALL SCREW	STEEL
11	#9 X 2-1/4" PFH WOOD SCREW	STEEL
16	LATCH STRIKE PLATE	STEEL
17	DEADBOLT STRIKE PLATE	STEEL
18	DEADBOLT SUB-STRIKE PLATE	STEEL
19	SILLKEY	ABS
24	#9 X 3/4" PFH WS	STEEL
25	#9 X 1" PFH WS	STEEL
26	#10 X 2" PFH WS	STEEL
27	#8 X 2-1/2" PFH WOOD SCREW	STEEL
28	#10 X 3" PFH WOOD SCREW	STEEL
29	4" X 4" HINGE	STEEL
31	INSWING THRESHOLD ALUMINUM w/ COMPOSITE SUBSTRATE	ALUM/ COMP
32	SIDELITE SPACER - INSWING	PVC
33	OUTSWING HIGH - DAM THRESHOLD ALUMINUM w/ COMPOSITE SUBSTRATE	ALUM/ COMP
34	SIDELITE SPACER - OUTSWING	PVC
40	DOOR PANEL	-
50	SIDELITE PANEL	-
52	#8 X 1" FH WOOD SCREW	STEEL
53	ENDURA ULTIMATE HURRICANE ASTRAGAL	ALUM
54	ASTRAGAL STRIKE PLATE	STEEL



Documents Prepared By: Lyndon F. Schmidt, P.E.
TEXAS P.E. #104123

RW BUILDING CONSULTANTS, INC.
P.O. Box 230 Valrico FL 33595
Phone No.: 813.659.9197

CERTIFICATE OF REGISTRATION # F-11852

PRODUCT: TRINITY GLASS INT'L

PART OR ASSEMBLY: BILL OF MATERIALS

NO.	DATE	BY	REVISIONS

DATE: 4/15/21

SCALE: N.T.S.

DWG. BY: RW

CHK. BY: LFS

DRAWING NO.: TX-5173

SHEET 10 OF 10

CONCRETE ANCHOR NOTES:

- Concrete anchor locations at the corners may be adjusted to maintain the min. edge distance to mortar joints.
- Concrete anchor locations noted as "MAX. ON CENTER" must be adjusted to maintain the min. edge distance to mortar joints, additional concrete anchors may be required to ensure the "MAX. ON CENTER" dimension are not exceeded.
- Concrete anchor table:

ANCHOR TYPE	ANCHOR SIZE	MIN. EMBEDMENT	MIN. CLEARANCE TO MASONRY EDGE	MIN. CLEARANCE TO ADJACENT ANCHOR
ITW TAPCON®	1/4"	1-3/4"	2"	4"
DeWALT ULTRACON®	1/4"	1-3/4"	1"	4"

WOOD SCREW INSTALLATION NOTES:

- Maintain a minimum 5/8" edge distance, 1" end distance, & 1" o.c. spacing of wood screws to prevent the splitting of wood.