



# "Restorations" Series Sliding Patio Door "NON-IMPACT"



Documents Prepared By: Lyndon F. Schmidt, P.E.  
TEXAS P.E. #104123

**RW** BUILDING CONSULTANTS, INC.  
P.O. Box 230 Valrico FL 33595  
Phone No.: 813.659.9197

TEXAS BOARD OF PROFESSIONAL ENGINEERS  
CERTIFICATE OF REGISTRATION # F-11852

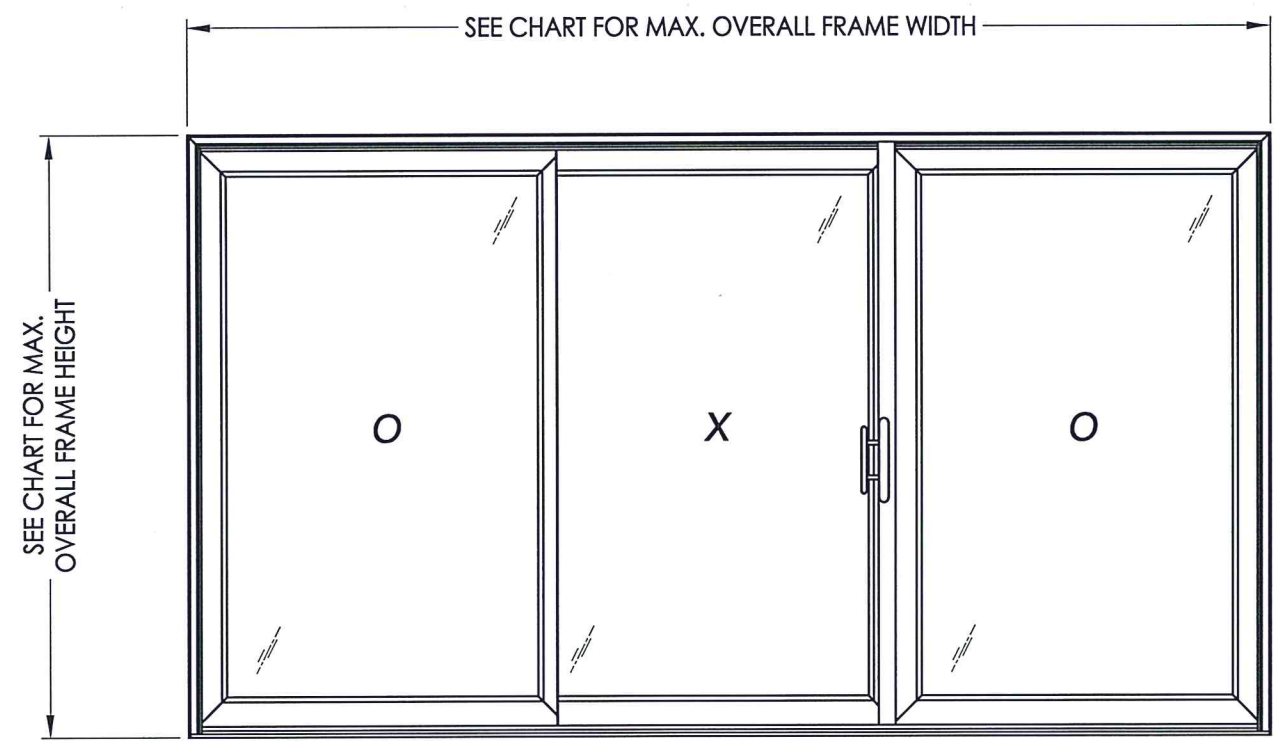

### EVALUATED FOR USE IN THE STATE OF TEXAS

The Sliding Patio Door described herein complies with the 2018 International Residential Code (IRC), Sections R301 & R609 and the 2018 International Building Code (IBC), Sections 1404.13, 1609, 1709.5, 2403 and 2404 subject to the following conditions:

1. Anchors shall be as listed and spaced as shown in the details. Anchor embedment to base material shall be beyond roof covering.
2. When used in areas requiring wind-borne debris protection this product is required to be protected with an impact resistant covering that complies with Section R301.2.1.2 of the IRC and Section 1609.2 of the IBC.
3. Allowable design pressure requirements must be equal to or less than the design pressure rating shown in the design pressure chart, sheet 1 of this drawing.
4. Conditions not covered by this drawing are subject to further engineering analysis.

TABLE OF CONTENTS	
SHEET#	DESCRIPTION
1	Typical elevation, design pressures & general notes
2	Horizontal & vertical cross sections
3	Frame anchoring
4	Components
5	Bill of materials & glazing detail

OVERALL FRAME DIMENSION	MAX. PANEL DIMENSION	MAX. D.L.O. DIMENSION	GLASS TYPE	DESIGN PRESSURE (PSF)	
				POSITIVE	NEGATIVE
107.5" X 79.5"	35.5" X 76.43"	29.25" X 68.81"	G1	+30.0	-45.0

PRODUCT: SUNRISE WINDOWS	
PART OR ASSEMBLY: TYPICAL ELEVATION, DESIGN PRESSURES & GENERAL NOTES	
NO.	DATE
BY	REVISIONS
DATE: 4/29/21	
SCALE: N.T.S.	
DWG. BY: RW	
CHK. BY: LFS	
DRAWING NO.: TX-5196	
SHEET 1 OF 5	

Z:\Clients\Sunrise Windows\B - Texas Dept of Ins\TDI - XXX ID xxxx SGD Restorations\C - Drawings\TX-5196.dwg

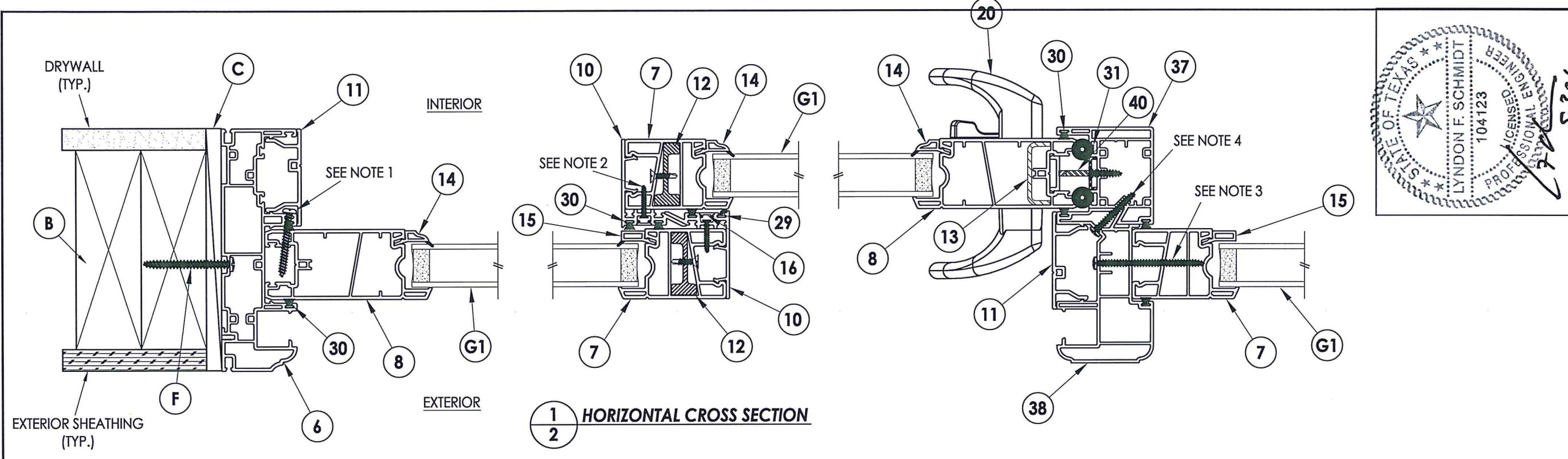

**1**  
**2** HORIZONTAL CROSS SECTION

**NOTES:**

1. FIXED SASH PANEL SECURED TO JAMB w/ (3) #8 X 1-1/4" PH SMS LOCATED 6" FROM ENDS AND @ CENTERLINE.
2. INTERLOCK SECURED w/ (3) #8 X 3/4" PH SMS LOCATED 12" FROM ENDS AND @ CENTERLINE.
3. FIXED SASH PANEL SECURED TO ASTRAGAL w/ (5) #8 X 2-1/2" PH SMS LOCATED 10" FROM ENDS PLUS 3 MORE EQUALLY SPACED.
4. EXTERIOR ASTRAGAL SECURED TO INTERIOR ASTRAGAL w/ (5) #8 X 1-1/4" PH SMS LOCATED 13.5" FROM ENDS PLUS 3 MORE EQUALLY SPACED.

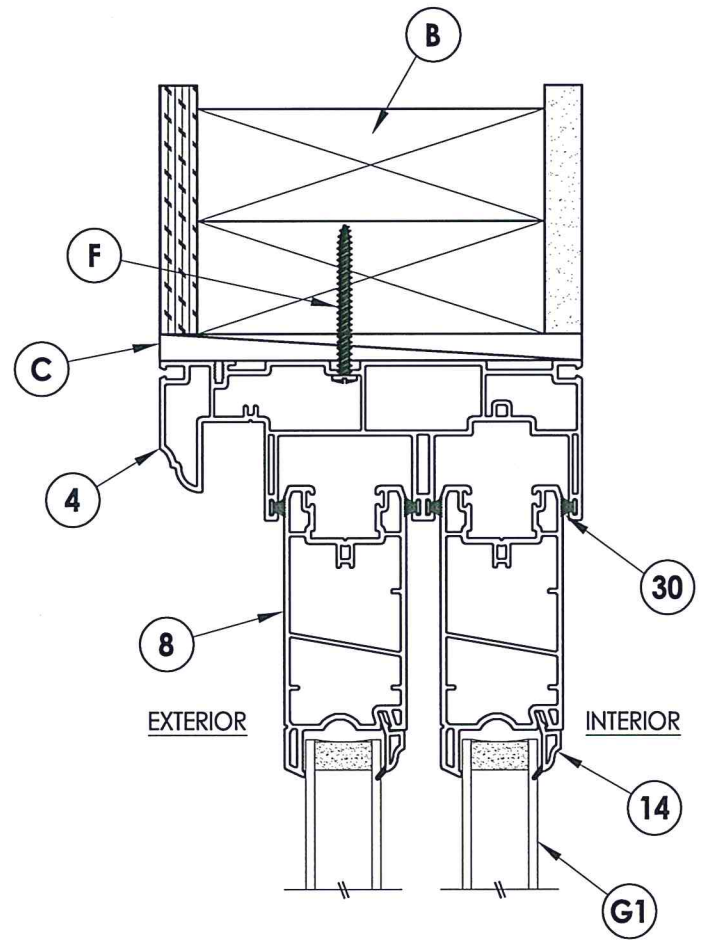
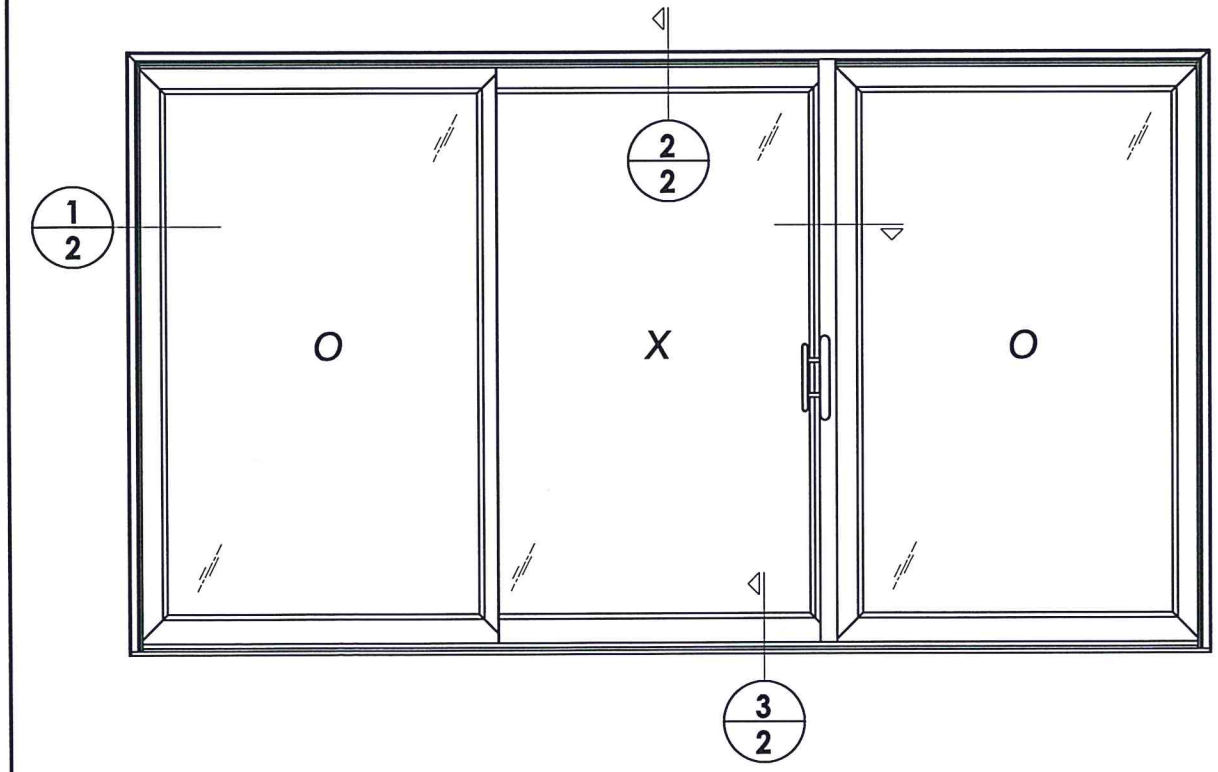

**2**  
**2** VERTICAL CROSS SECTION

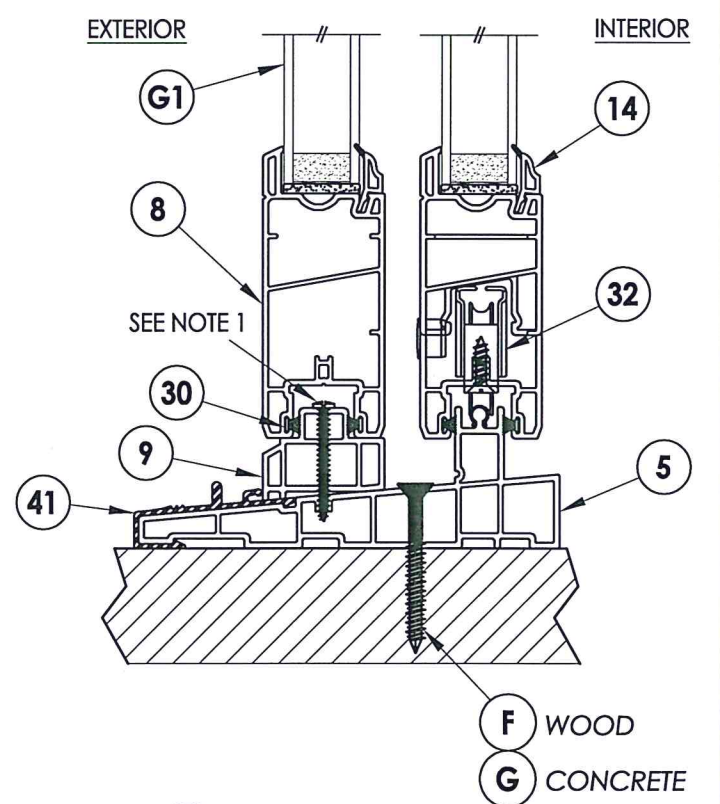

**3**  
**2** VERTICAL CROSS SECTION

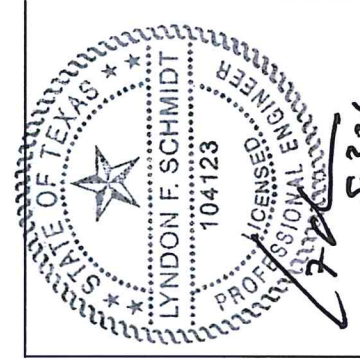

Documents Prepared By: Lyndon F. Schmidt, P.E.  
TEXAS P.E. #104123

RW BUILDING CONSULTANTS, INC.  
P.O. Box 230 Valrico FL, 33595  
Phone No.: 813.659.9197

TEXAS BOARD OF PROFESSIONAL ENGINEERS  
CERTIFICATE OF REGISTRATION # F-11852

PRODUCT: SUNRISE WINDOWS  
PART OR ASSEMBLY: HORIZONTAL & VERTICAL CROSS SECTIONS

NO.	DATE	BY	REVISIONS

DATE: 4/29/21  
SCALE: N.T.S.  
DWG. BY: RW  
CHK. BY: LFS  
DRAWING NO.: TX-5196  
SHEET 2 OF 5

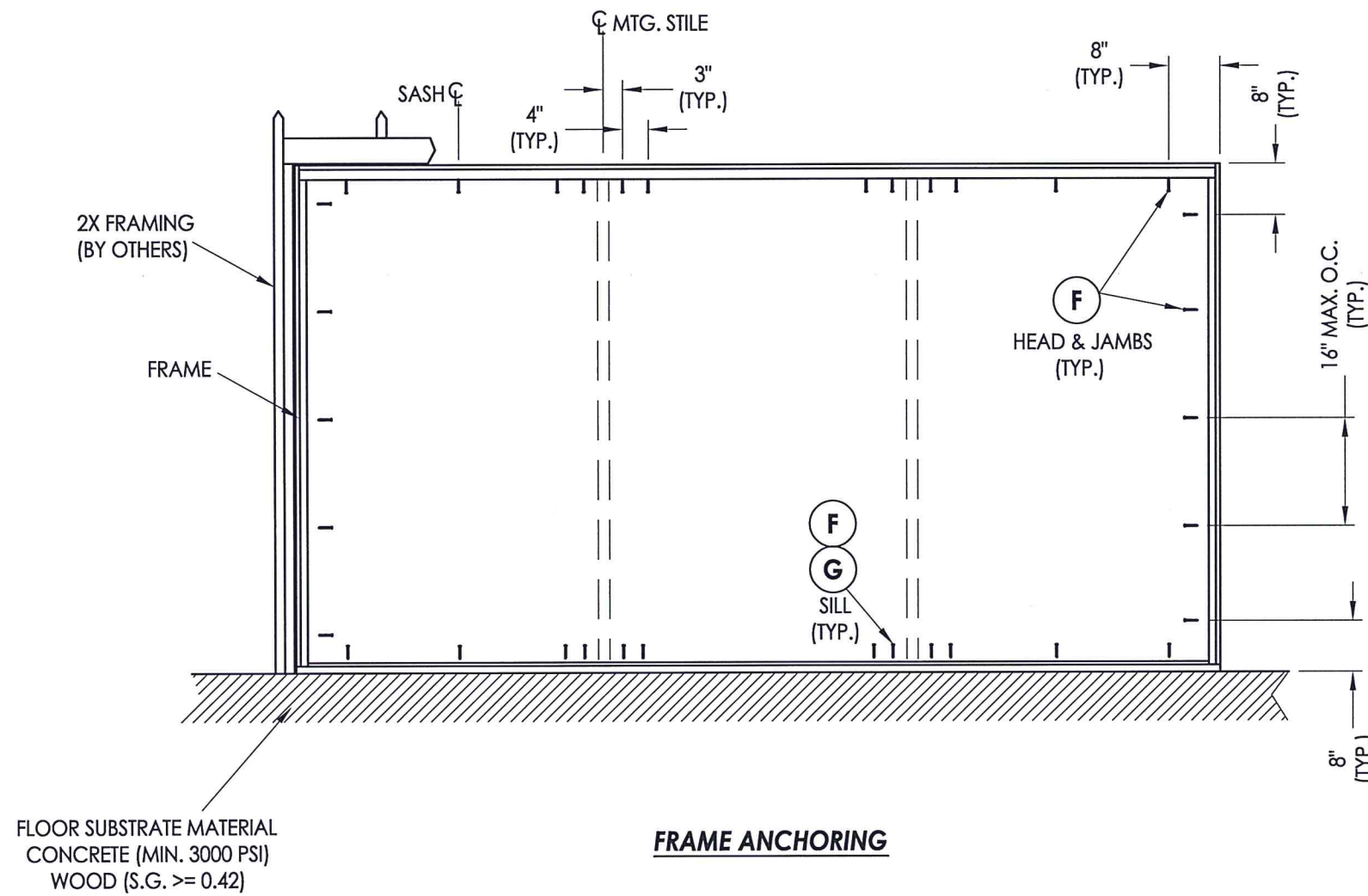

CONCRETE ANCHOR NOTES:

- 1. Concrete anchor locations at the corners may be adjusted to maintain the min. edge distance to mortar joints.
- 2. Concrete anchor locations noted as "MAX. ON CENTER" must be adjusted to maintain the min. edge distance to mortar joints, additional concrete anchors may be required to ensure the "MAX. ON CENTER" dimension are not exceeded.
- 3. Concrete anchor table:

ANCHOR TYPE	ANCHOR SIZE	MIN. EMBEDMENT	MIN. CLEARANCE TO MASONRY EDGE	MIN. CLEARANCE TO ADJACENT ANCHOR
ITW TAPCON®	1/4"	1-3/4"	1-1/2"	4"
DeWALT ULTRACON®	1/4"	1-3/4"	2-1/2"	4"

WOOD SCREW INSTALLATION NOTES:

- 1. Maintain a minimum 5/8" edge distance, 1" end distance, & 1" o.c. spacing of wood screws to prevent the splitting of wood.

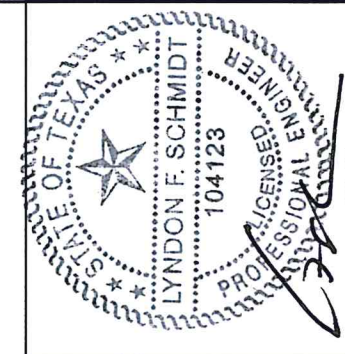

Documents Prepared By: Lyndon F. Schmidt, P.E.  
TEXAS P.E. #104123

RW BUILDING CONSULTANTS, INC.  
P.O. Box 230 Valrico FL 33595  
Phone No.: 813.659.9197  
TEXAS BOARD OF PROFESSIONAL ENGINEERS  
CERTIFICATE OF REGISTRATION # F-11852

PRODUCT: SUNRISE WINDOWS  
PART OR ASSEMBLY: FRAME ANCHORING

NO.	DATE	BY	REVISIONS

DATE: 4/29/21  
SCALE: N.T.S.  
DWG. BY: RW  
CHK. BY: LFS  
DRAWING NO.: TX-5196  
SHEET 3 OF 5

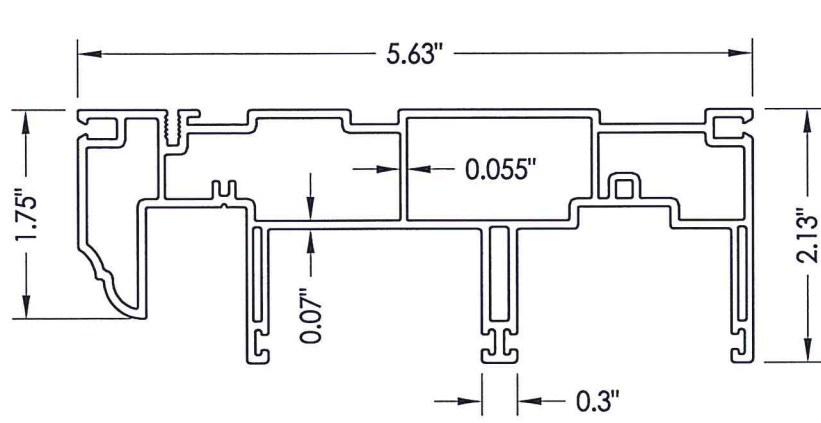

4 PD HEAD JAMB

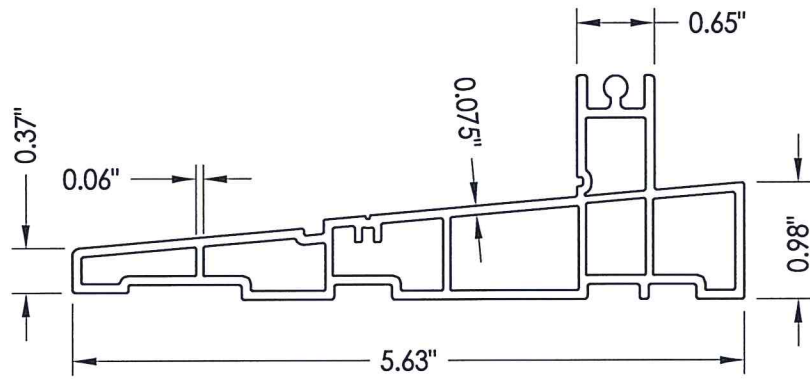

5 PD SILL

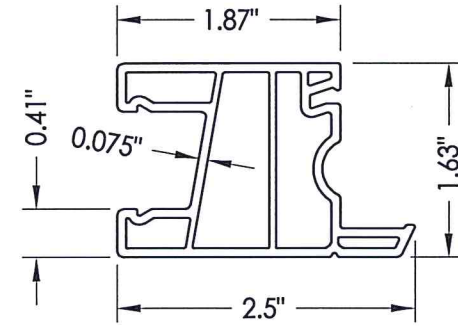

7 PD SASH Meeting Stile

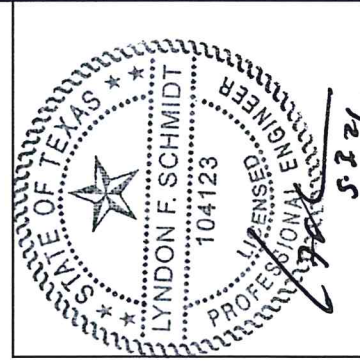

Documents Prepared By: Lyndon F. Schmidt, P.E.  
TEXAS P.E. #104123

**RW** BUILDING CONSULTANTS, INC.  
P.O. Box 230 Valrico FL 33595  
Phone No.: 813.659.9197  
TEXAS BOARD OF PROFESSIONAL ENGINEERS  
CERTIFICATE OF REGISTRATION # F-11852

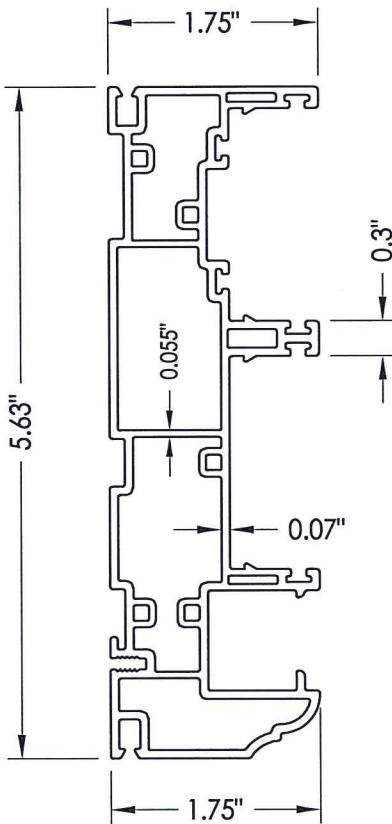

6 PD JAMB

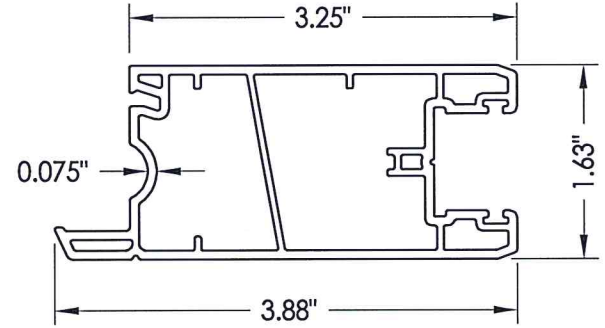

8 PD SASH Jamb Stile

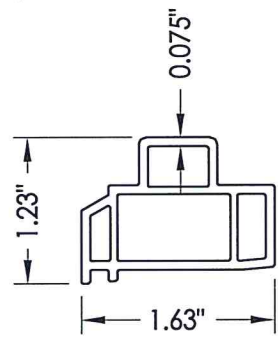

9 RISER

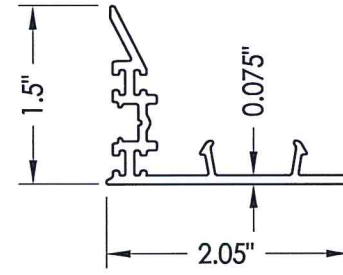

10 INTERLOCK Meeting Stile

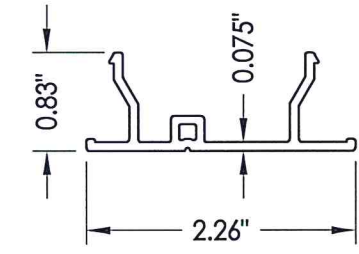

11 JAMB COVER

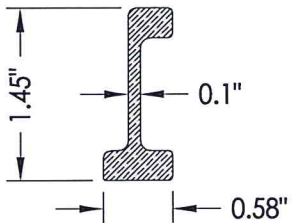

12 REINFORCEMENT Meeting Stiles

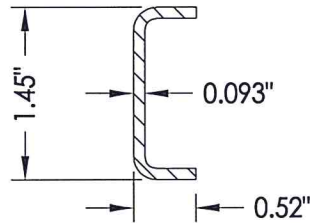

13 REINFORCEMENT Lock Stile

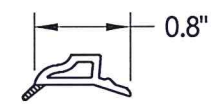

14 GLAZING BEAD

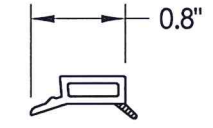

15 GLAZING BEAD

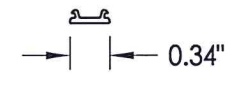

16 INTERLOCK SCREW COVER

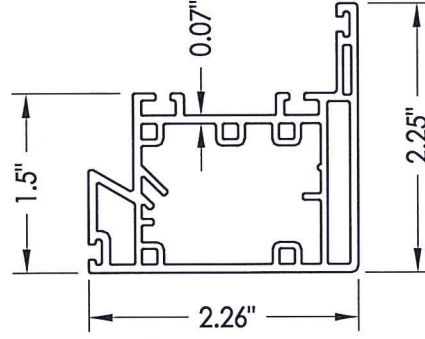

37 ASTRAGAL Exterior

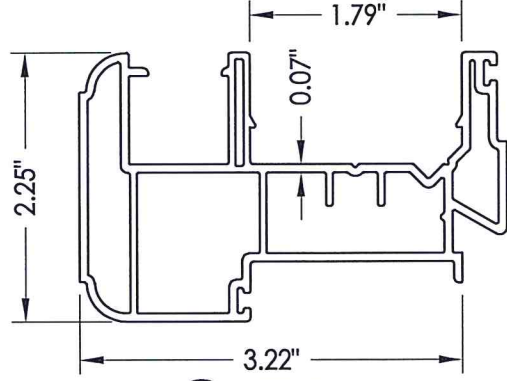

38 ASTRAGAL Exterior

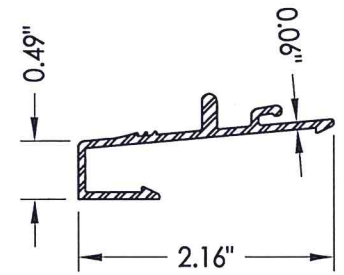

41 SILL NOSING

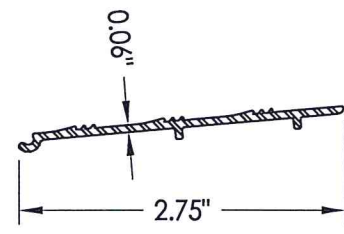

42 SILL EXTENDER

PRODUCT:	SUNRISE WINDOWS
PART OR ASSEMBLY:	COMPONENTS

NO.	DATE	REVISIONS	BY

DATE:	4/29/21
SCALE:	N.T.S.
DWG. BY:	RW
CHK. BY:	LFS
DRAWING NO.:	TX-5196
SHEET	4 OF 5

**BILL OF MATERIALS**

ITEM #	DESCRIPTION	MATERIAL
B	2X FRAMING (SG >= 0.42)	WOOD
C	3/8" MAX. SHIM SPACE	-
F	#10 X 2" PPH SMS (1-3/8" MIN. EMBEDMENT)	STEEL
G	1/4" FH DeWALT OR ITW CONCRETE SCREW (1-3/4" MIN. EMBEDMENT)	STEEL
4	PD HEAD JAMB*	RIGID PVC
5	PD SILL*	RIGID PVC
6	PD JAMB*	RIGID PVC
7	PD SASH MEETING STILE*	RIGID PVC
8	PD SASH JAMB STILE*	RIGID PVC
9	RISER*	RIGID PVC
10	INTERLOCK MEETING STILE*	RIGID PVC
11	JAMB COVER*	RIGID PVC
12	REINFORCEMENT MEETING STILES	FIBERGLASS
13	REINFORCEMENT LOCK STILE	STEEL
14	GLAZING BEAD*	RIGID PVC
15	GLAZING BEAD (FIXED MEETING STILE)*	RIGID PVC
16	INTERLOCK SCREW COVER*	RIGID PVC
20	PULL HANDLE	-
29	BULB WEATHERSTRIP	-
30	FIN WEATHERSTRIP	-
31	BULB WEATHERSTRIP	NEOPRENE
32	ROLLER ASSY.	-
37	ASTRAGAL INTERIOR*	RIGID PVC
38	ASTRAGAL EXTERIOR*	RIGID PVC
40	LATCH BAR	STEEL
41	SILL NOSING	ALUM
42	SILL EXTENDER (NOT SHOWN)	ALUM

\* THE APPROVED WHITE RIGID PVC EXTERIOR EXTRUSIONS FOR WINDOWS ARE TO BE PRODUCED BY EXTRUDERS LICENSEES IN "AAMA CERTIFICATION PROGRAMS FOR RIGID PVC EXTRUSIONS".

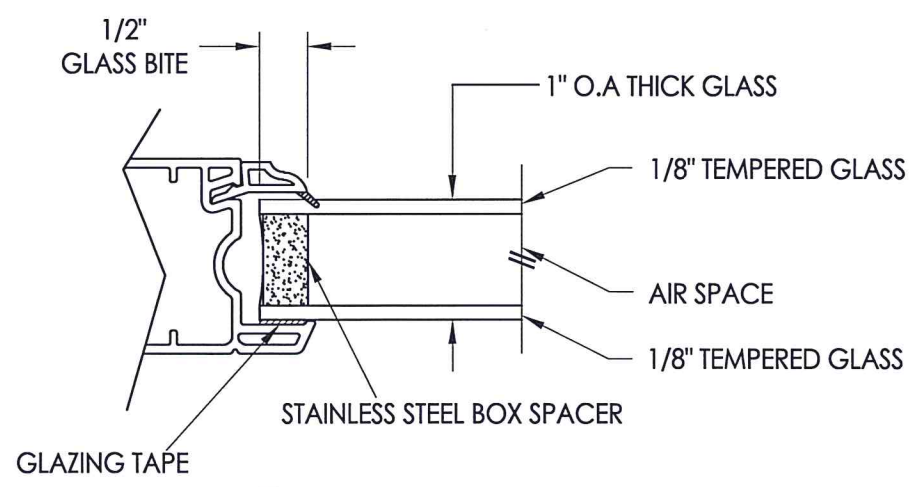

**G1 GLAZING DETAIL**



Documents Prepared By: Lyndon F. Schmidt, P.E.  
TEXAS P.E. #104123

**RW** BUILDING CONSULTANTS, INC.  
P.O. Box 230 Valrico FL 33595  
Phone No.: 813.659.9197  
TEXAS BOARD OF PROFESSIONAL ENGINEERS  
CERTIFICATE OF REGISTRATION # F-11852

PRODUCT: SUNRISE WINDOWS  
PART OR ASSEMBLY: BILL OF MATERIALS & GLAZING DETAILS

NO.	DATE	BY	REVISIONS

DATE: 4/29/21  
SCALE: N.T.S.  
DWG. BY: RW  
CHK. BY: LFS  
DRAWING NO.: TX-5196  
SHEET 5 OF 5