

THERMA-TRU® DOORS

Fiber-Classic® & Smooth-Star®

WOOD OR COMPOSITE EDGE OPAQUE FIBERGLASS SINGLE DOOR w/ DIRECT SET SIDELITE(S)

**INSWING
"NON-IMPACT"**

EVALUATED FOR USE IN THE STATE OF TEXAS

The Fiberglass Door system described herein complies with the 2018 International Residential Code (IRC), Sections R301 & R609 and the 2018 International Building Code (IBC), Sections 1404.13, 1609, 1709.5, 2403 and 2404 subject to the following conditions:

1. Anchors shall be as listed and spaced as shown in the details. Anchor embedment to base material shall be beyond wall dressing or stucco.
2. When used in areas requiring wind-borne debris protection this product is required to be protected with an impact resistant covering that complies with Section R301.2.1.2 of the IRC and Section 1609.1.2 of the IBC.
3. Allowable design pressure requirements must be equal to or less than the design pressure rating shown in the design pressure chart, sheet 1 of this drawing.
4. Conditions not covered by this drawing are subject to further engineering analysis.
5. Fiber-Classic and Smooth-Star Door and Sidelite panels require the use of "J" part numbers. These door and sidelite panels must be stained or painted within six months of installation.

TABLE OF CONTENTS			
SHEET #	DESCRIPTION	SHEET #	
1	Typical Elevations, Design Pressures & General Notes	6	Vertical Cross Sections
2	Door Panel Details	7	Frame Anchoring
3	Sidelite Panel Details	8	Hardware Details
4	Elevations	9	Bill of Materials & Components
5	Horizontal Cross Sections		

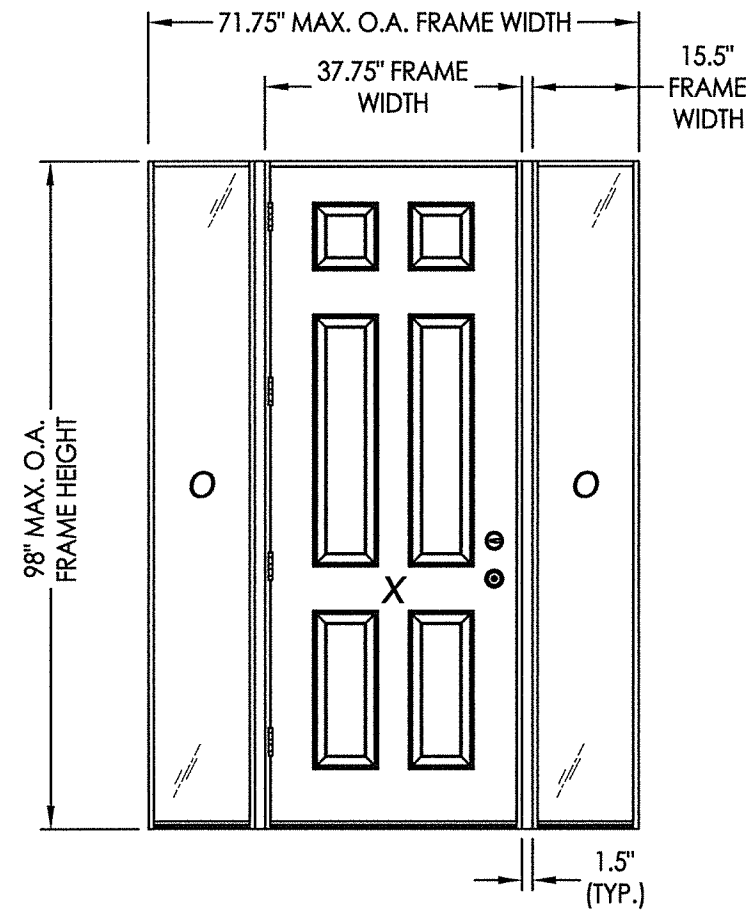
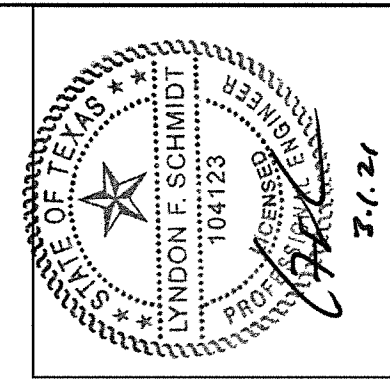
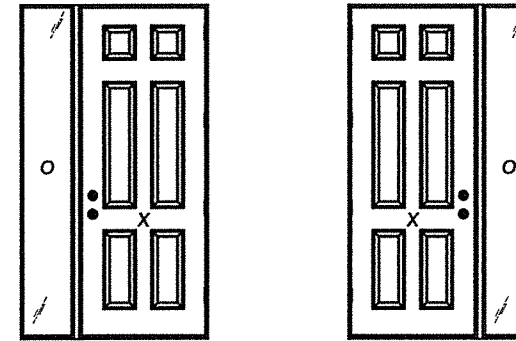

CONFIGURATION	2X REINFORCEMENT REQUIRED	DESIGN PRESSURE (PSF) w/ FJ PINE JAMBS		DESIGN PRESSURE (PSF) w/ COMPOSITE JAMBS	
		POSITIVE	NEGATIVE	POSITIVE	NEGATIVE
XO, OX, OXO	NO	+40.0	-45.0	+30.0	-40.0
	YES	+50.0	-55.0	+50.0	-55.0

Documents Prepared By: Lyndon F. Schmidt, P.E.
TEXAS P.E. #104123

RW BUILDING CONSULTANTS, INC.
P.O. Box 230 Valrico FL 33595
Phone No.: 813.659.9197

TEXAS BOARD OF PROFESSIONAL ENGINEERS
CERTIFICATE OF REGISTRATION # F-11852

PRODUCT:		PART OR ASSEMBLY:	
THERMA-TRU FIBERGLASS DOOR		TYPICAL ELEVATION, DESIGN PRESSURES & GENERAL NOTES	
NO.	DATE	BY	REVISIONS

DATE: 1/06/21
SCALE: N.T.S.
DWG. BY: RW
CHK. BY: LFS
DRAWING NO.: TX-5138
SHEET 1 OF 9

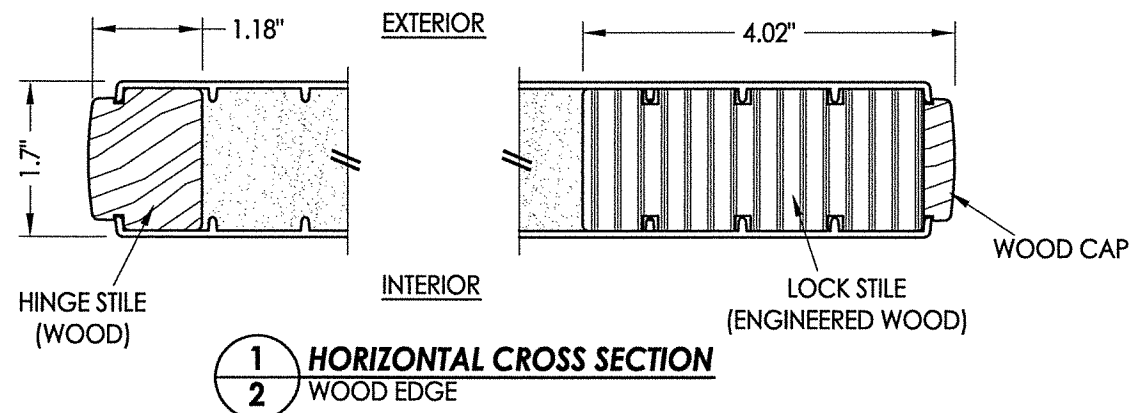

1 HORIZONTAL CROSS SECTION
2 WOOD EDGE

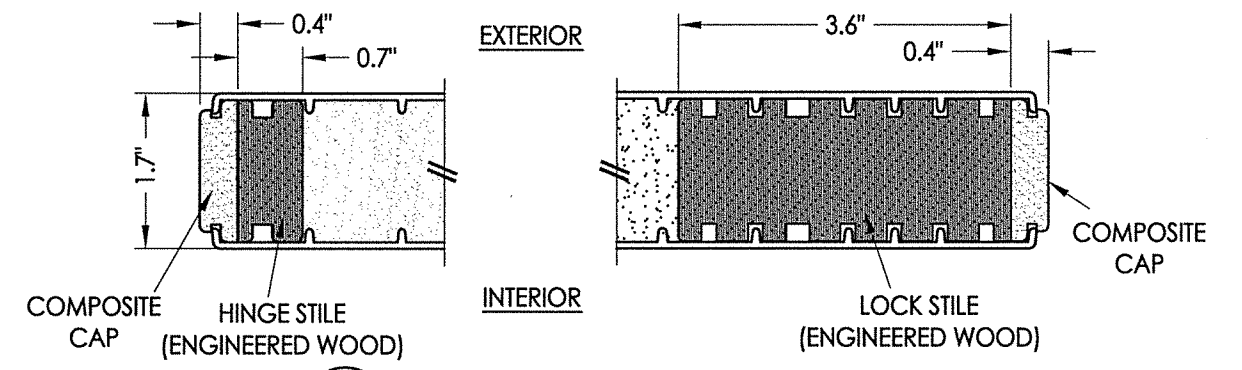

2 HORIZONTAL CROSS SECTION
2 COMPOSITE EDGE

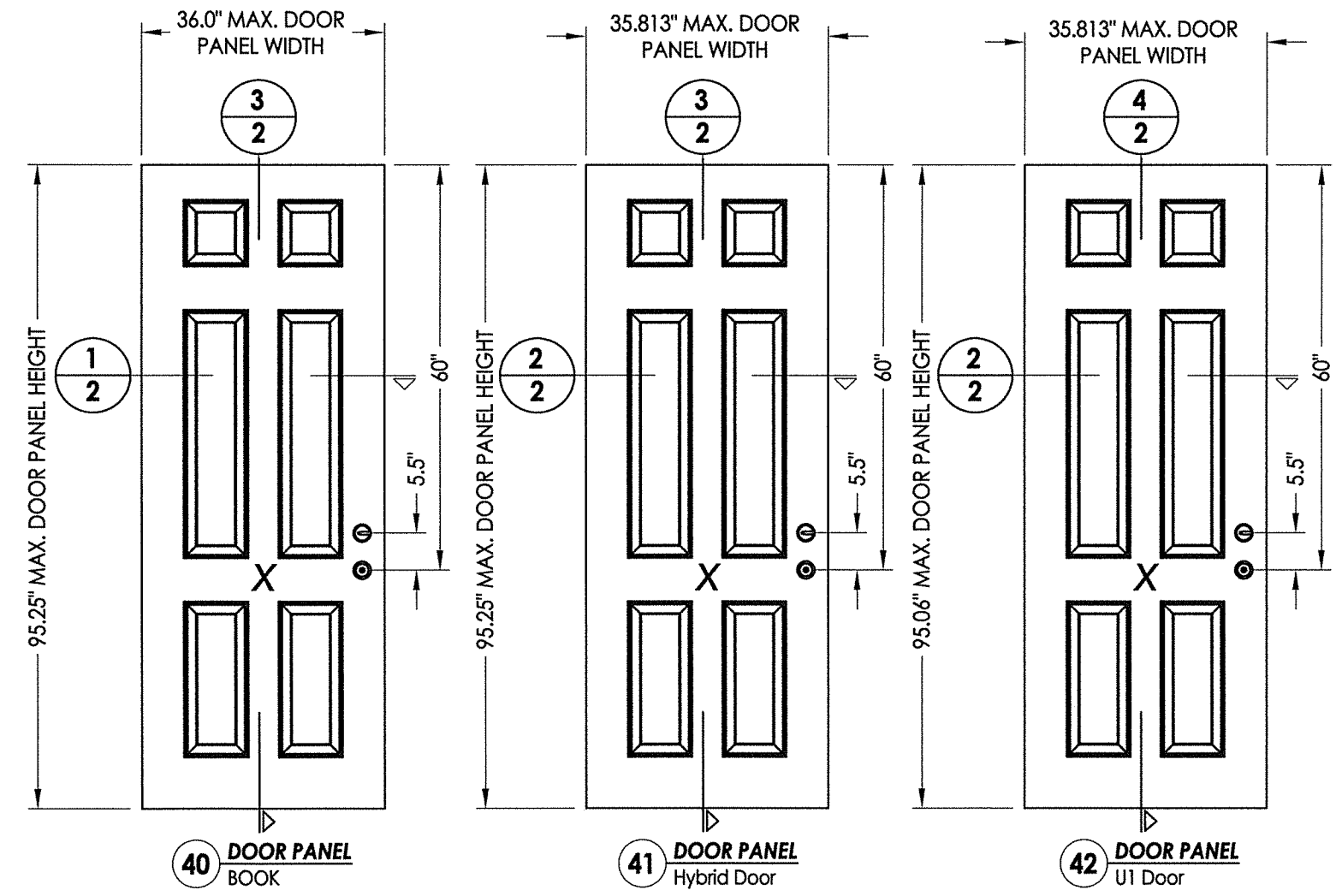

40 DOOR PANEL
BOOK

41 DOOR PANEL
Hybrid Door

42 DOOR PANEL
U1 Door

NOTE: BOOK, HYBRID & U1 DOORS
MAY EACH BE FABRICATED AS WOOD
OR COMPOSITE EDGE DOORS.

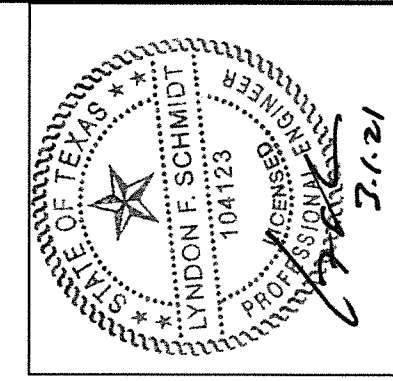

Documents Prepared By: Lyndon F. Schmidt, P.E.
TEXAS P.E. #104123

RW BUILDING CONSULTANTS, INC.
P.O. Box 230 Valrico FL 33595
Phone No.: 813.659.9197

TEXAS BOARD OF PROFESSIONAL ENGINEERS
CERTIFICATE OF REGISTRATION # F-11852

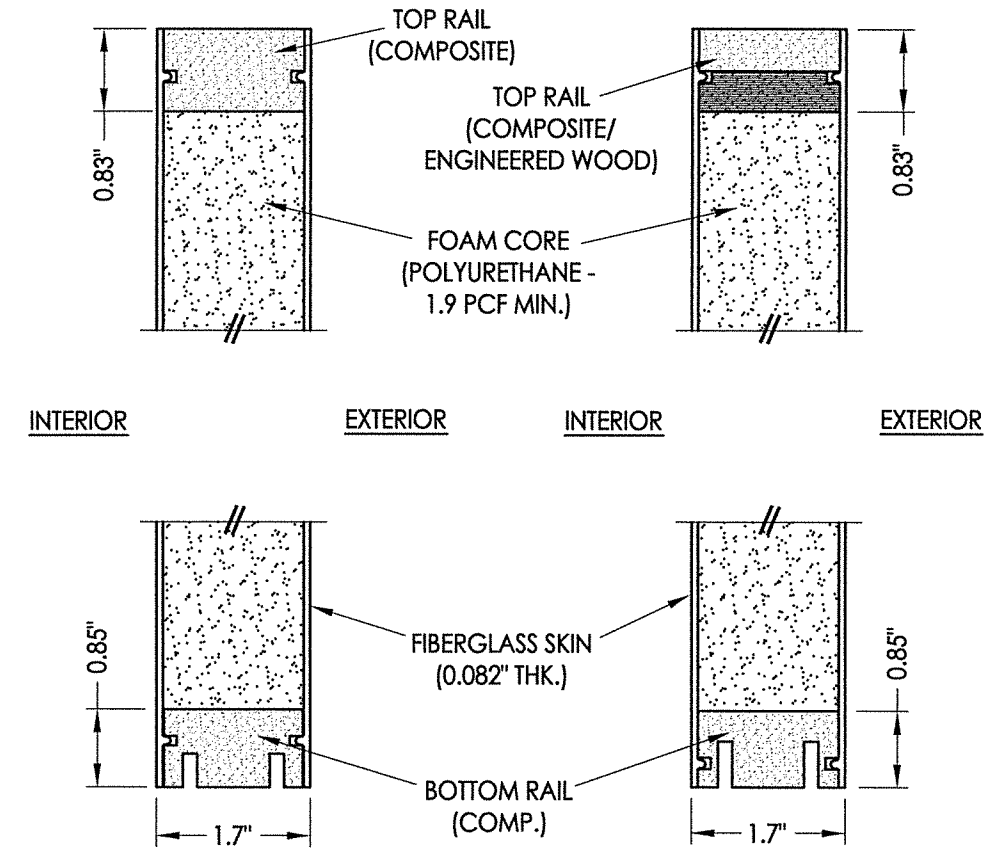

3 VERTICAL CROSS SECTION
2 WOOD EDGE

4 VERTICAL CROSS SECTION
2 COMPOSITE EDGE

PRODUCT: THERMA-TRU FIBERGLASS DOOR	
PART OR ASSEMBLY: DOOR PANEL DETAILS	
NO.	DATE
BY	REVISIONS
DATE: 1/06/21	
SCALE: N.T.S.	
DWG. BY: RW	
CHK. BY: LFS	
DRAWING NO.: TX-5138	
SHEET 2 OF 9	

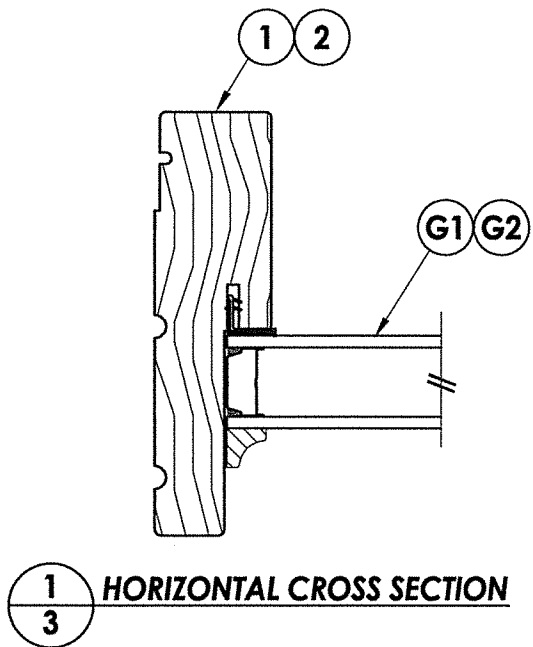

1
3 **HORIZONTAL CROSS SECTION**

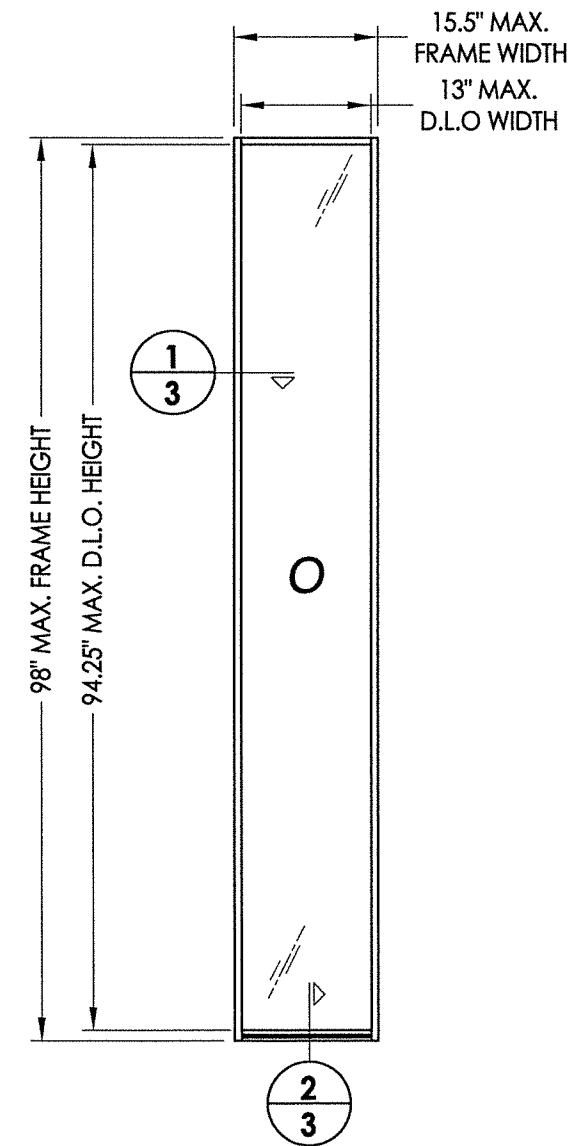

50 **SIDELITE PANEL**

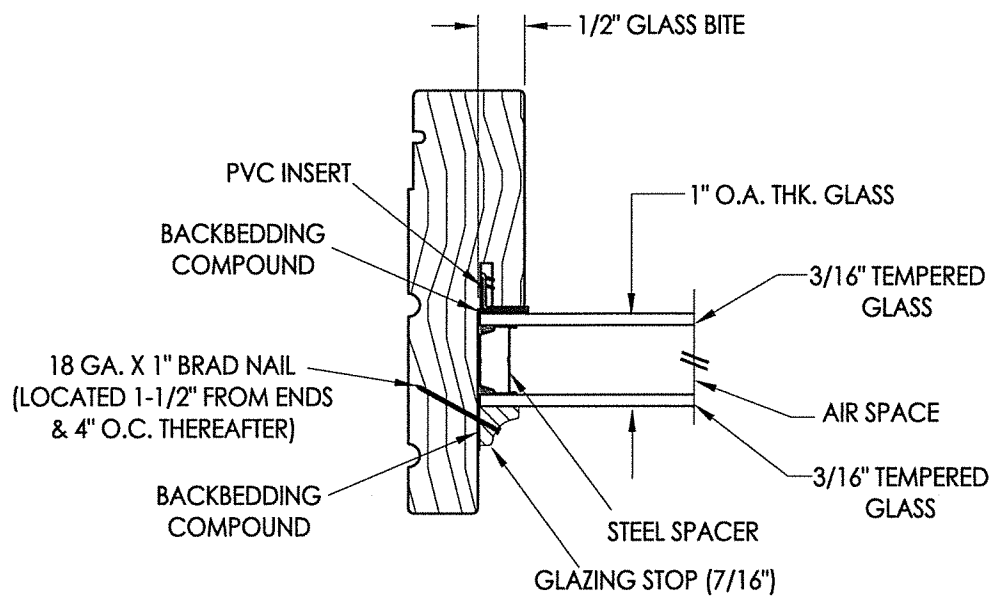

G1 **GLAZING DETAIL**
1" Insulated Glass

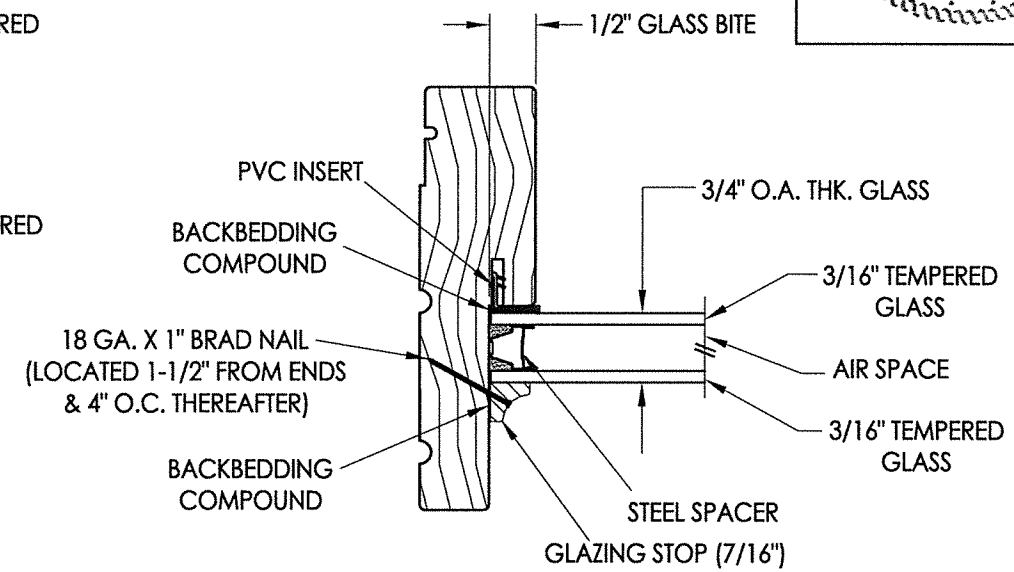

G2 **GLAZING DETAIL**
3/4" Insulated Glass

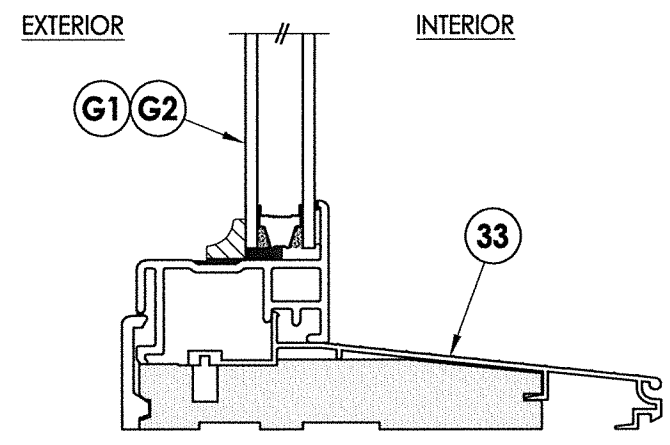

2
3 **VERTICAL CROSS SECTION**

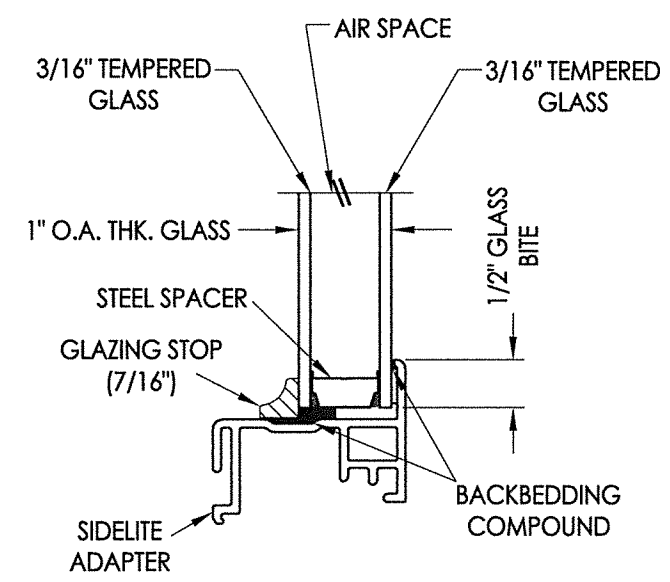

G1 **GLAZING DETAIL**
1" Insulated Glass

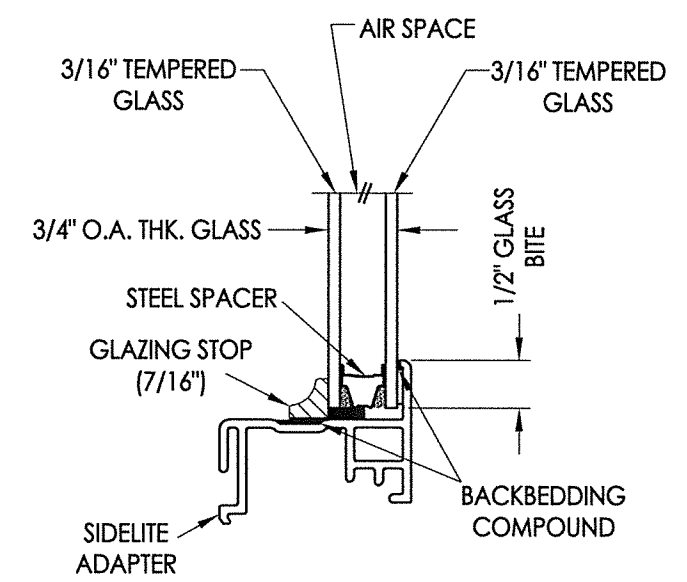

G2 **GLAZING DETAIL**
3/4" Insulated Glass

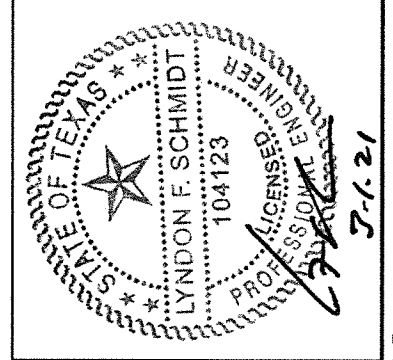

Documents Prepared By: Lyndon F. Schmidt, P.E.
TEXAS P.E. #104123

RW BUILDING CONSULTANTS, INC.
P.O. Box 230 Vairico FL 33595
Phone No.: 813.659.9197

TEXAS BOARD OF PROFESSIONAL ENGINEERS
CERTIFICATE OF REGISTRATION # F-11852

PRODUCT:	THERMA-TRU FIBERGLASS DOOR
PART OR ASSEMBLY:	SIDELITE PANEL DETAILS

NO.	DATE	BY

DATE:	1/06/21
SCALE:	N.T.S.
DWG. BY:	RW
CHK. BY:	LFS
DRAWING NO.:	TX-5138
SHEET	3 OF 9

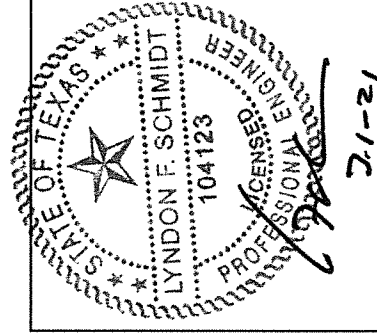
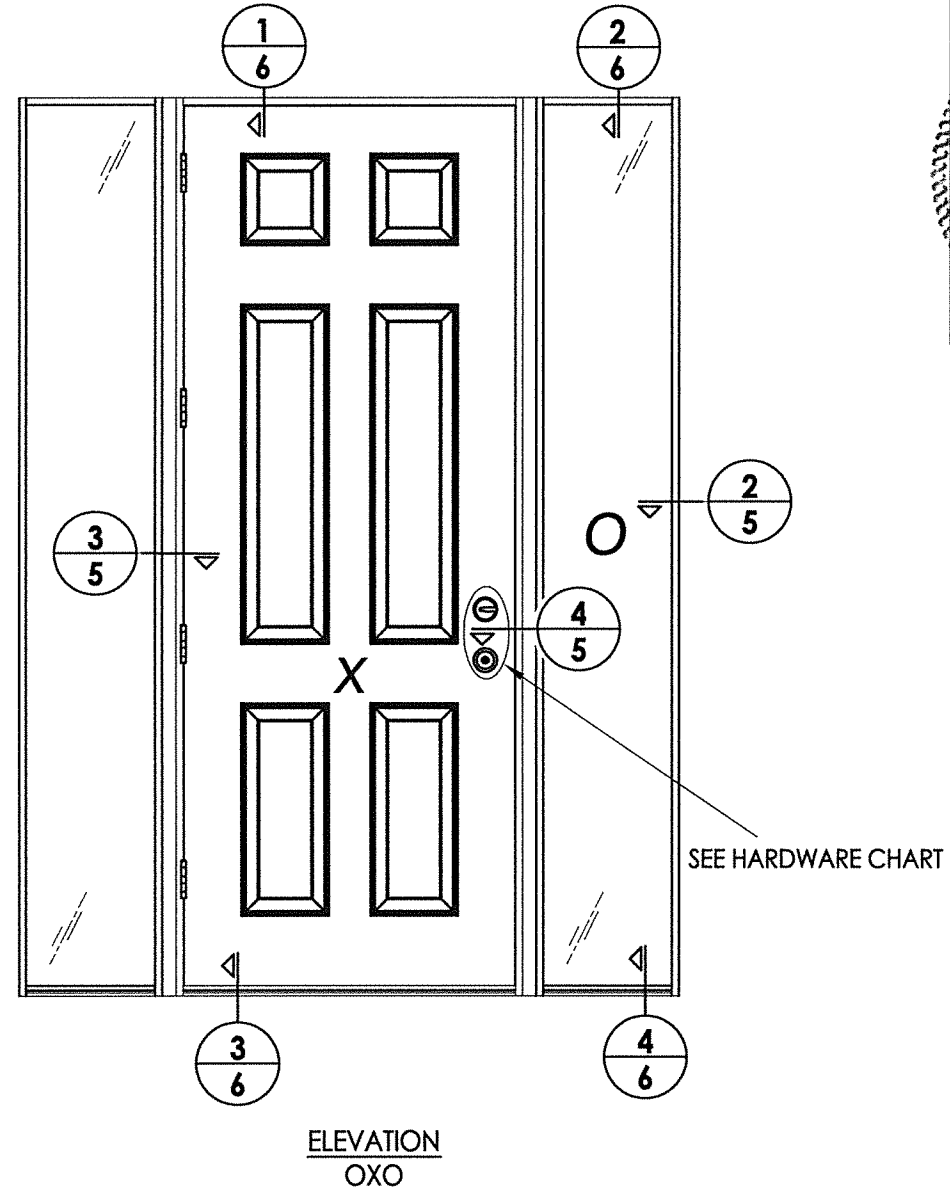
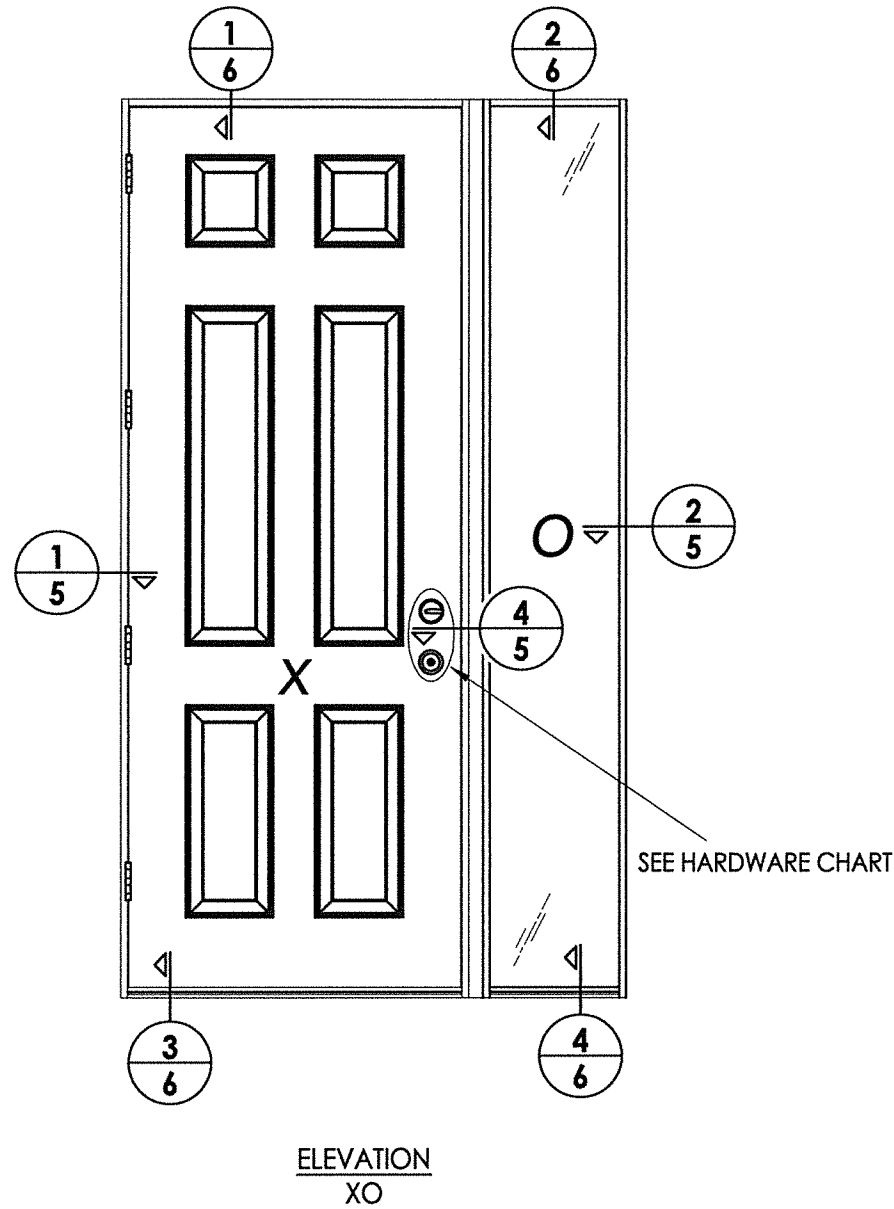

Documents Prepared By: Lyndon F. Schmidt, P.E.
TEXAS P.E. #104123

RW BUILDING CONSULTANTS, INC.
P.O. Box 230 Valrico FL 33595
Phone No.: 813.659.9197

TEXAS BOARD OF PROFESSIONAL ENGINEERS
CERTIFICATE OF REGISTRATION # F-11852

PRODUCT: THERMA-TRU
FIBERGLASS DOOR

PART OR ASSEMBLY:
ELEVATIONS

NO.	DATE	BY	REVISIONS

DATE: 1/06/21
SCALE: N.T.S.
DWG. BY: RW
CHK. BY: LFS
DRAWING NO.: TX-5138
SHEET 4 OF 9

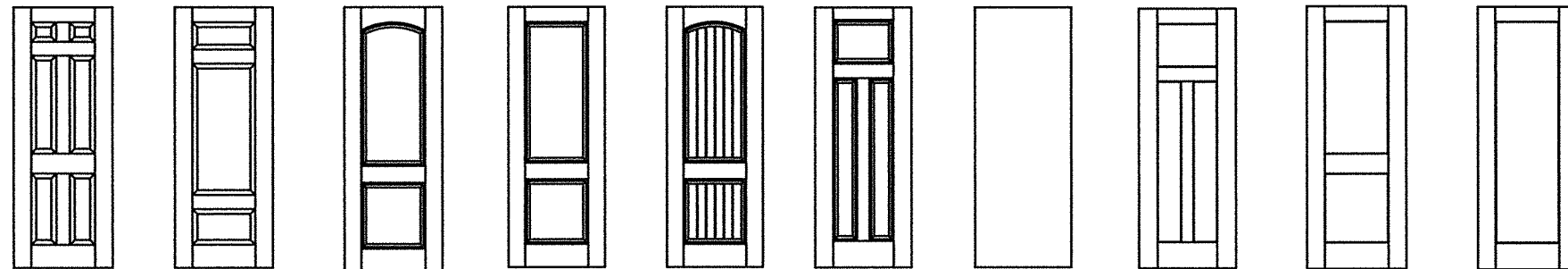

Fiber-Classic/Smooth-Star Door Panel Options

Products approved include all embossed and recessed panel doors.
Similar opaque panel configurations are allowed.
Panels shown are for illustration and are representative only.

HARDWARE TABLE	
MANUFACTURER	MODEL
SCHLAGE	KNOB: F51 DEADBOLT: B60
KWIKSET	KNOB: SIGNATURE SERIES DEADBOLT: SIGNATURE SERIES (980)

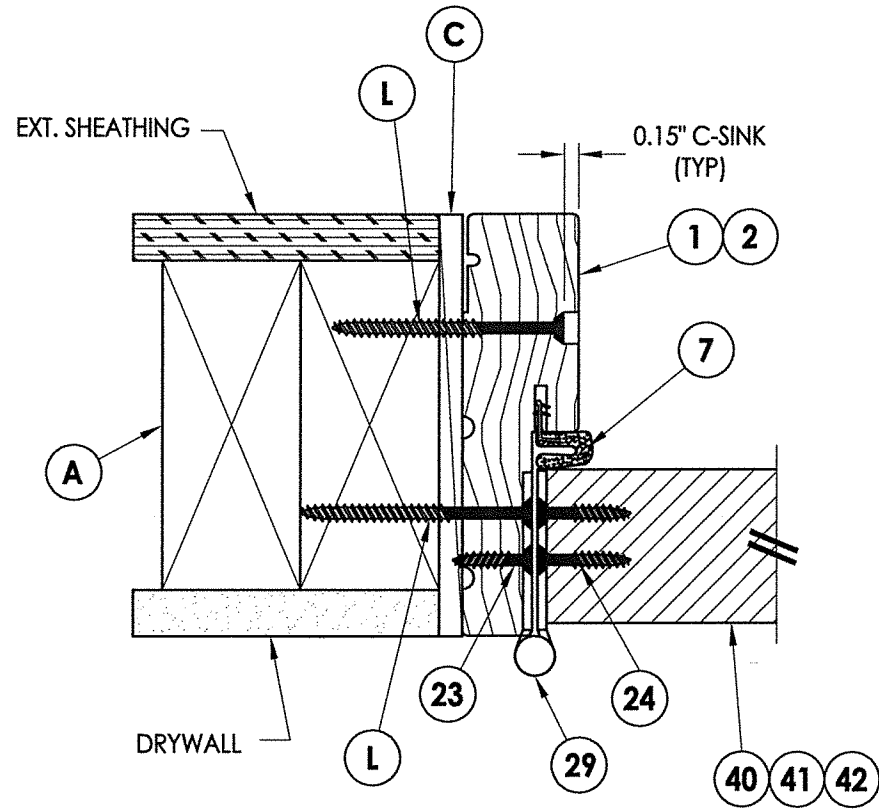

1
5 HORIZONTAL CROSS SECTION

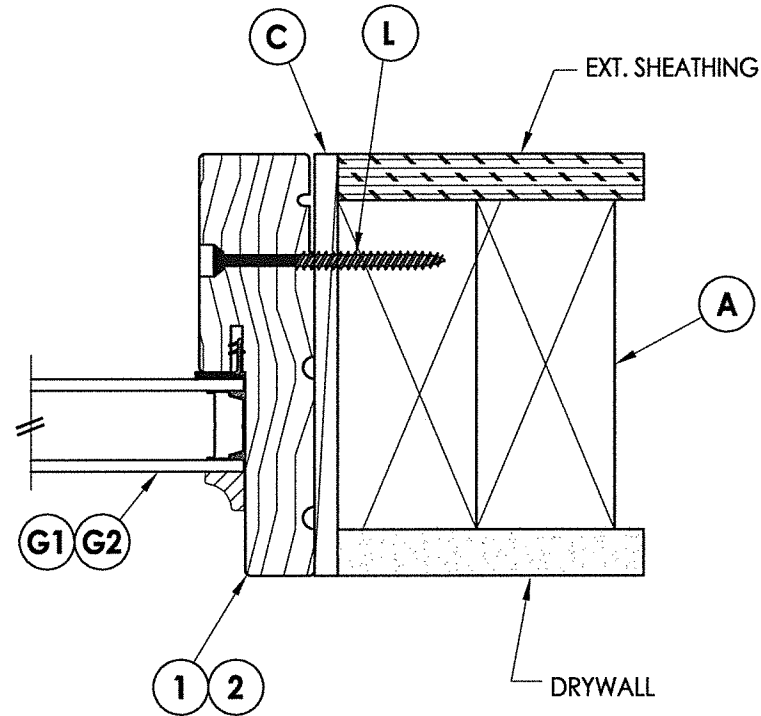

2
5 HORIZONTAL CROSS SECTION

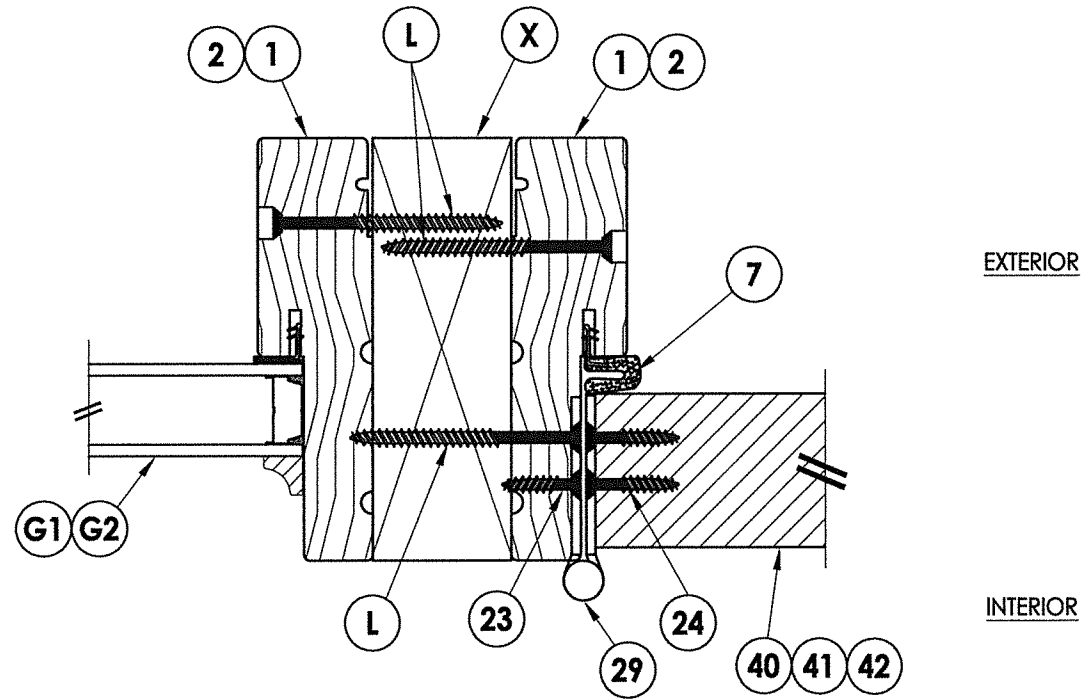

3
5 HORIZONTAL CROSS SECTION
Shown w/ 2X Reinforcement

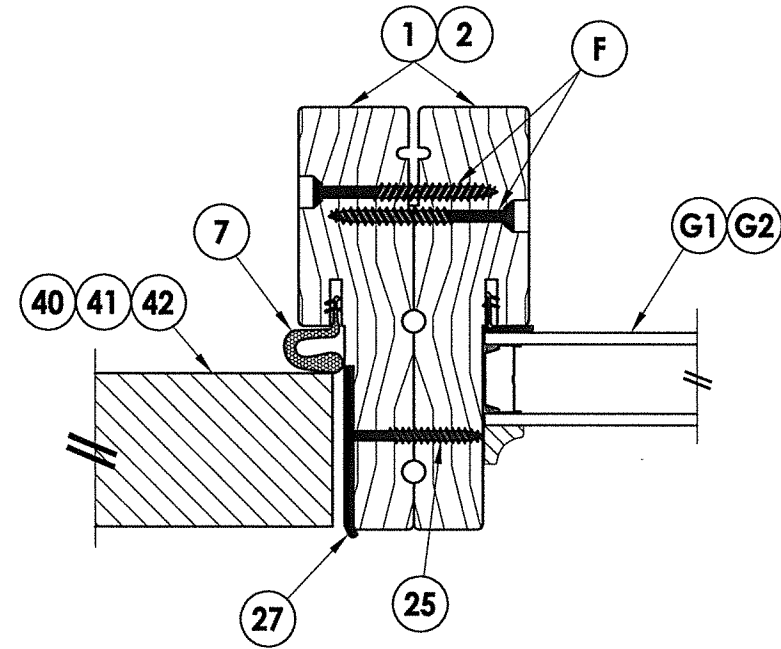

4
5 HORIZONTAL CROSS SECTION
Shown w/ Back-to-Back Jambs

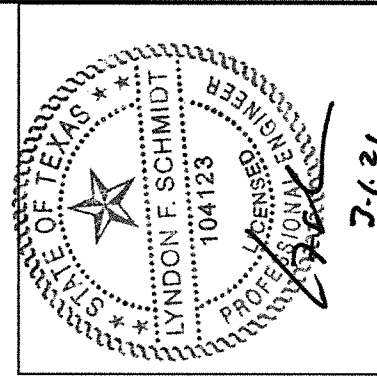

Documents Prepared By: Lyndon F. Schmidt, P.E.
TEXAS P.E. #104123

RW BUILDING CONSULTANTS, INC.
P.O. Box 230 Valrico FL 33595
Phone No.: 813.659.9197

TEXAS BOARD OF PROFESSIONAL ENGINEERS
CERTIFICATE OF REGISTRATION # F-11852

PRODUCT: THERMA-TRU FIBERGLASS DOOR

PART OR ASSEMBLY: HORIZONTAL CROSS SECTIONS

NO.	DATE	BY

DATE: 1/06/21
SCALE: N.T.S.
DWG. BY: RW
CHK. BY: LFS
DRAWING NO.: TX-5138
SHEET 5 OF 9

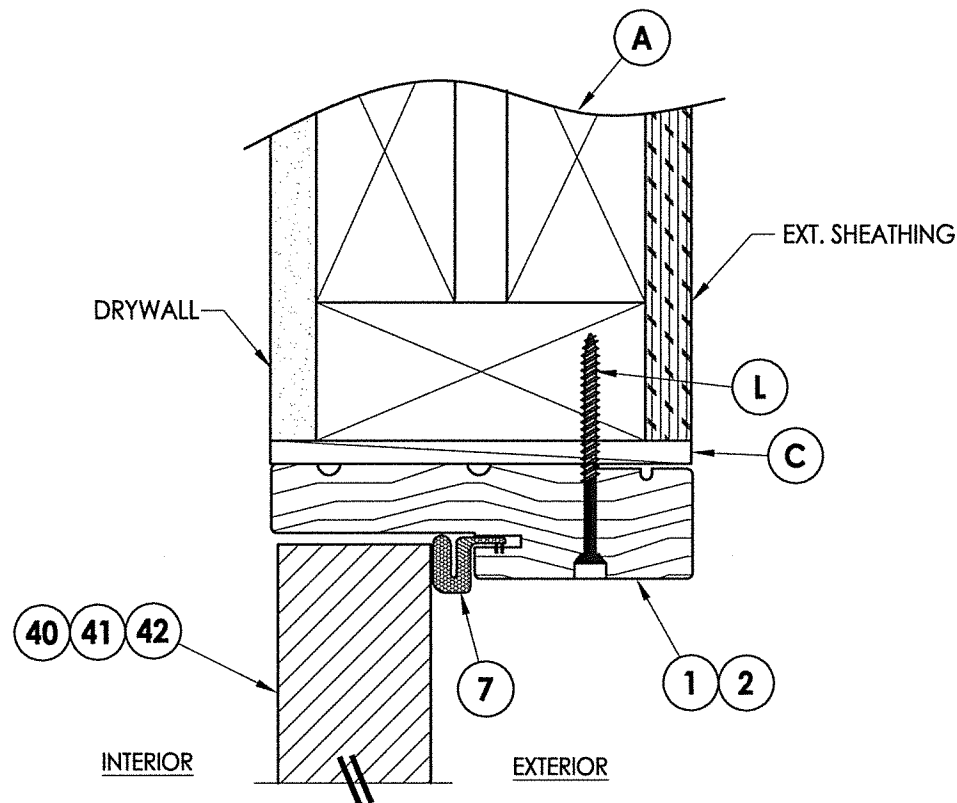

1
6 VERTICAL CROSS SECTION

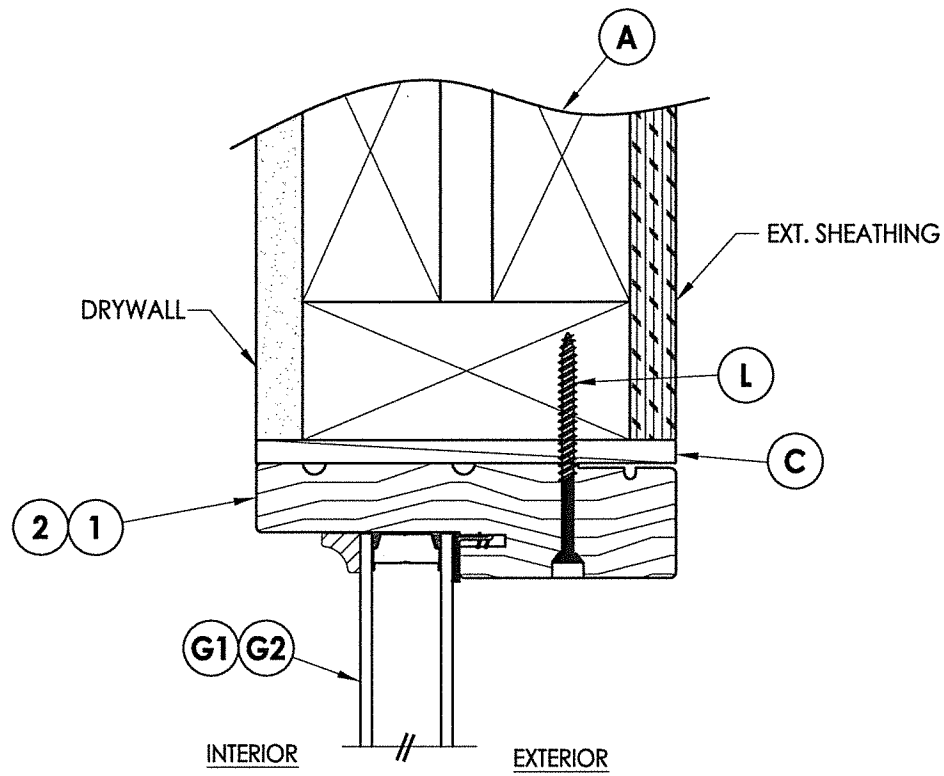

2
6 VERTICAL CROSS SECTION

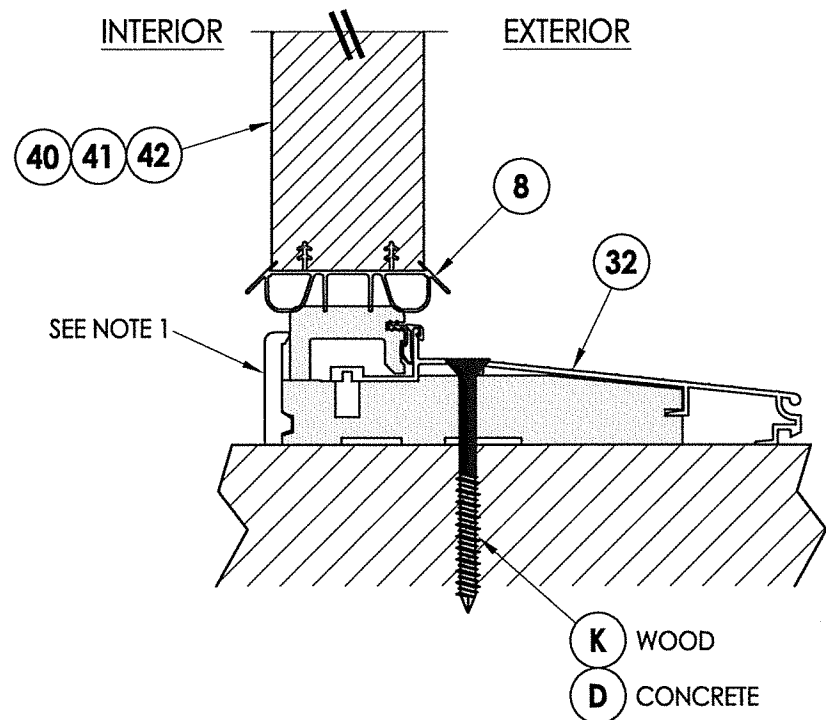

3
6 VERTICAL CROSS SECTION
Inswing Sill

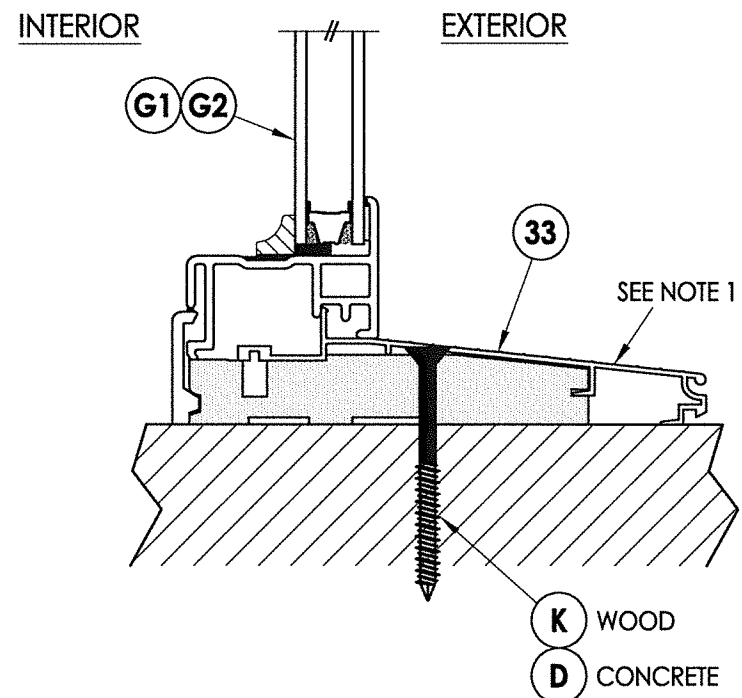

4
6 VERTICAL CROSS SECTION
Inswing Sill

Note:
1. Sill Item #'s 32 & 33 are attached to jambs w/ (3) #8 X 2-1/2" FH screws at each end.

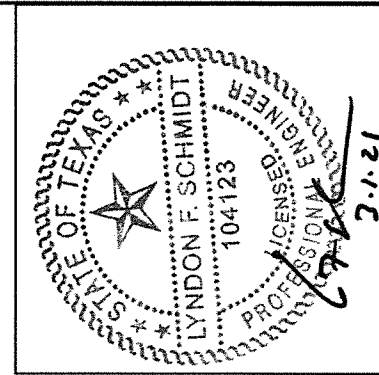

Documents Prepared By: Lyndon F. Schmidt, P.E.
TEXAS P.E. #104123

RW BUILDING CONSULTANTS, INC.
P.O. Box 230 Vairico FL. 33595
Phone No.: 813.659.9197
TEXAS BOARD OF PROFESSIONAL ENGINEERS
CERTIFICATE OF REGISTRATION # F-11852

PRODUCT: THERMA-TRU FIBERGLASS DOOR
PART OR ASSEMBLY: VERTICAL CROSS SECTIONS

NO.	DATE	BY	REVISIONS

DATE: 1/06/21

SCALE: N.T.S.

DWG. BY: RW

CHK. BY: LFS

DRAWING NO.: TX-5138

SHEET 6 of 9

Z:\Clients\Therma Tru PERMANENT\B - Texas Dept of Ins\TDI - DR XXX - 6'8, 7' & 8' Opaque FG NonImp IS Dir Set Sidelites (TX 5134-5139)C - Drawings\TX-5138-39.dwg

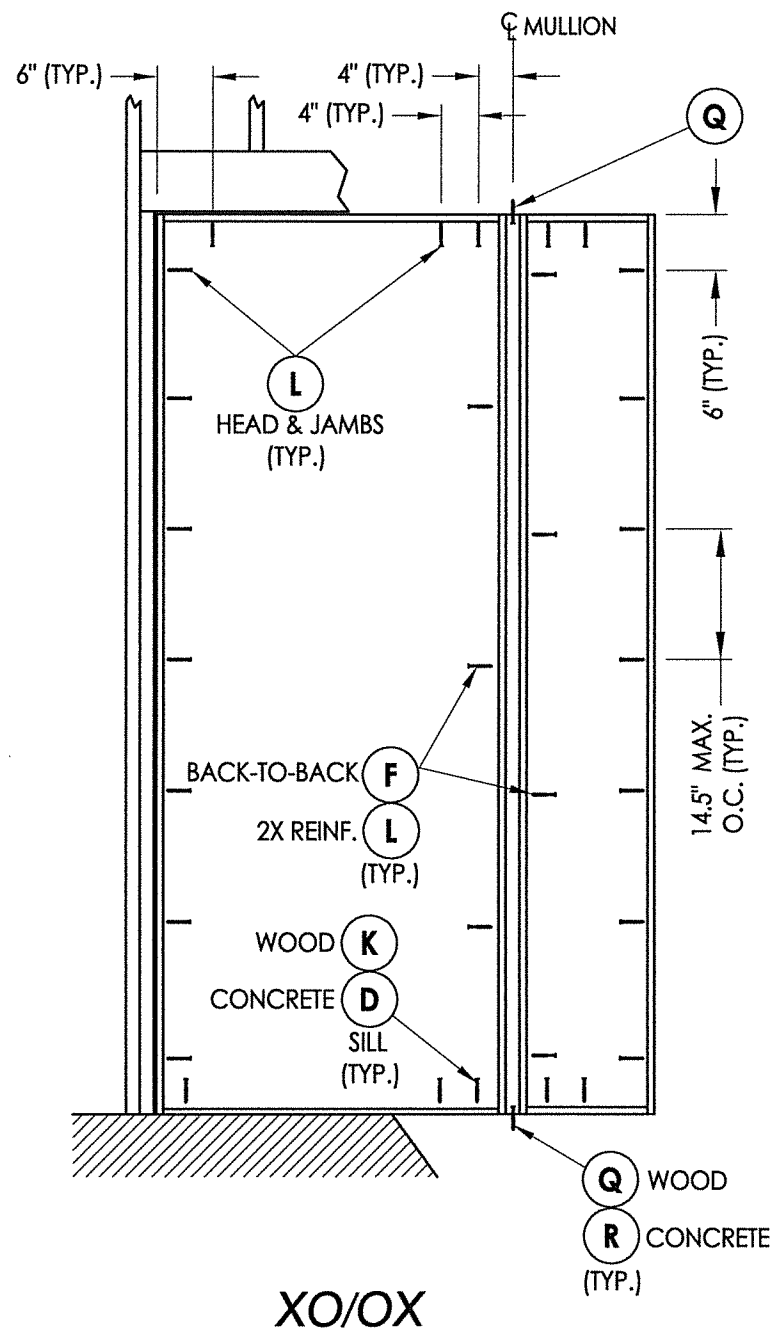

XO/OX

FRAME ANCHORING

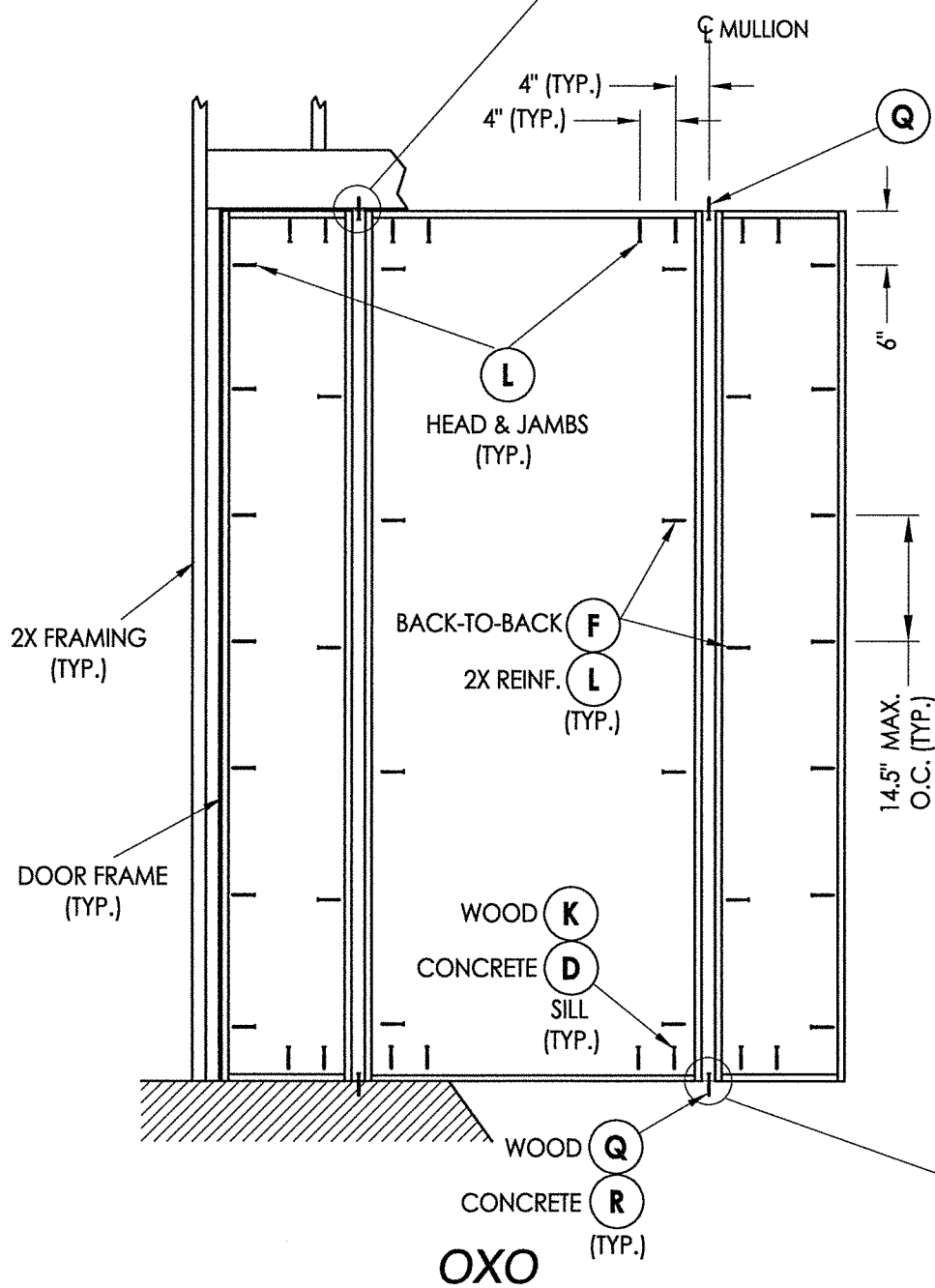

OXO

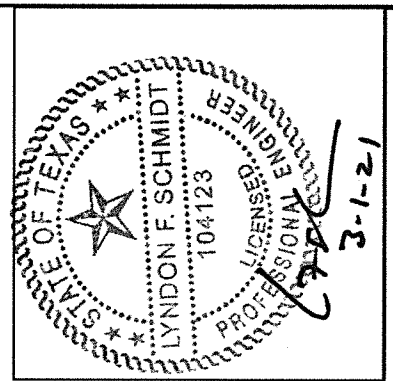
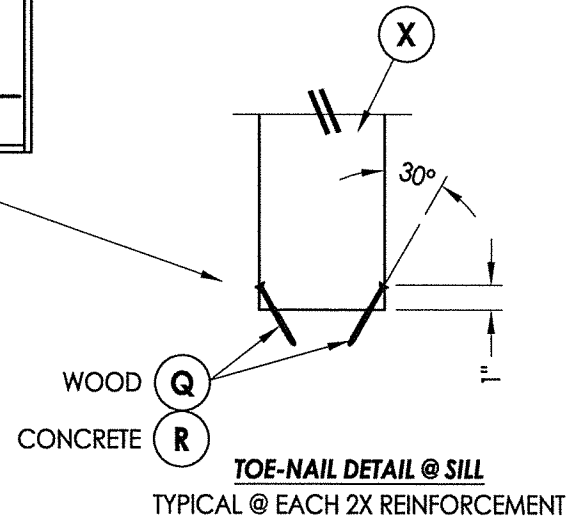
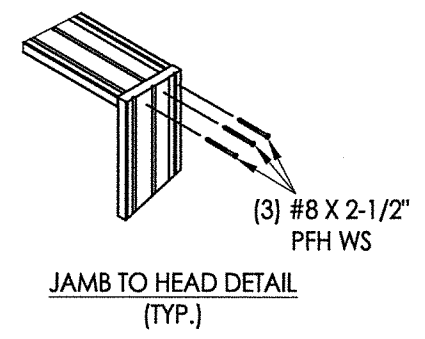
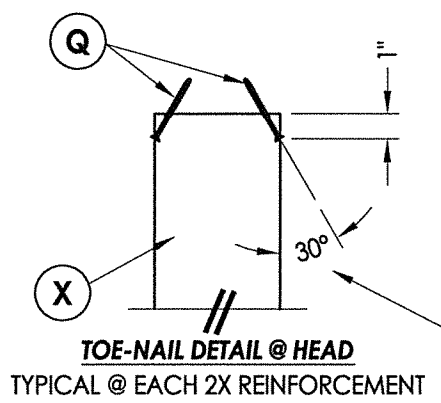

Documents Prepared By: Lyndon F. Schmidt, P.E.
TEXAS P.E. #104123

RW BUILDING CONSULTANTS, INC.
P.O. Box 230 Vaivico FL 33595
Phone No.: 813.659.9197

TEXAS BOARD OF PROFESSIONAL ENGINEERS
CERTIFICATE OF REGISTRATION # F-11852

PRODUCT:	THERMA-TRU FIBERGLASS DOOR
PART OR ASSEMBLY:	FRAME ANCHORING

NO.	DATE	BY	REVISIONS

DATE:	1/06/21
SCALE:	N.T.S.
DWG. BY:	RW
CHK. BY:	LFS
DRAWING NO.:	TX-5138
SHEET	7 OF 9

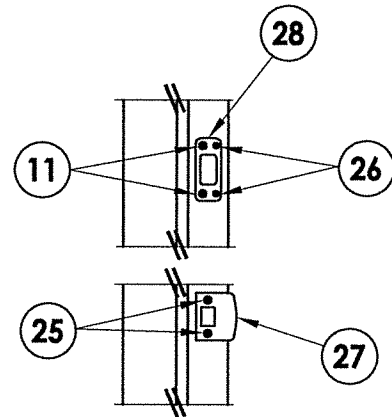

LATCH & DEADBOLT DETAIL
Kwikset

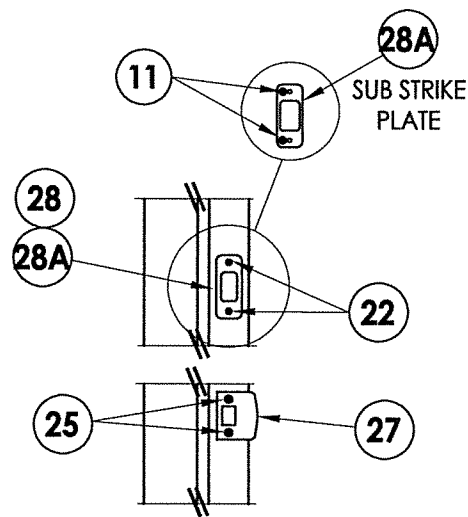

LATCH & DEADBOLT DETAIL
Schlage

LATCH & DEADBOLT STRIKE DETAILS

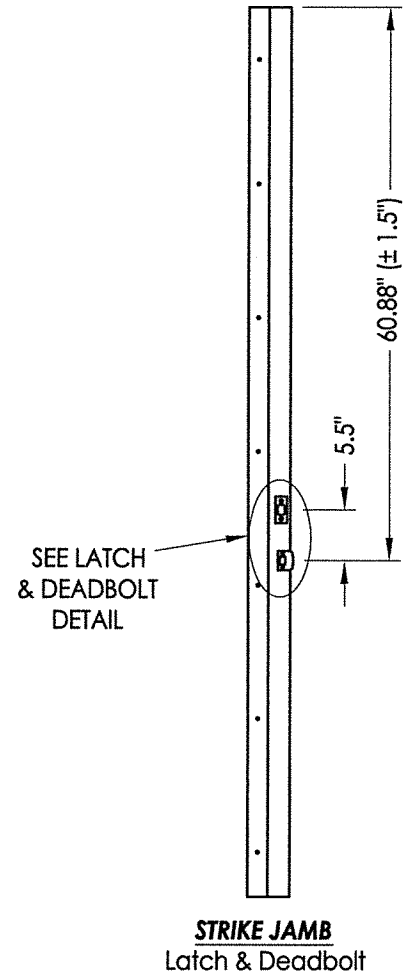

STRIKE JAMB
Latch & Deadbolt

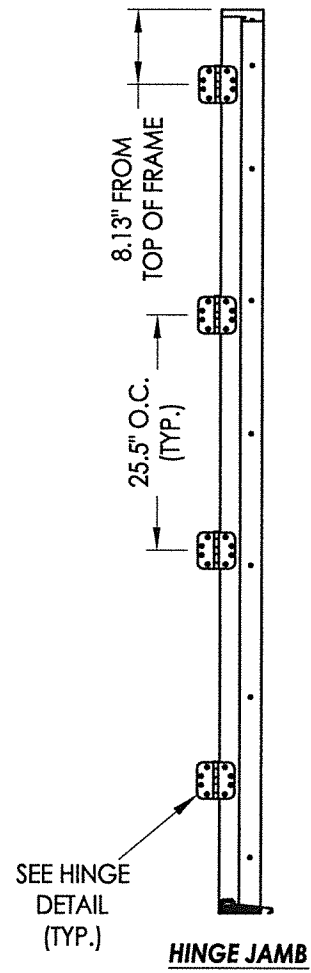

HINGE JAMB

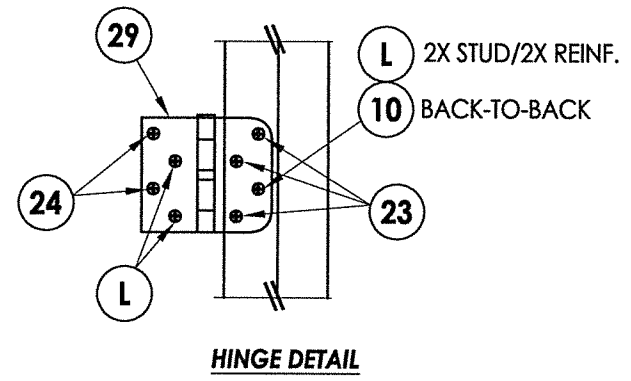

HINGE DETAIL

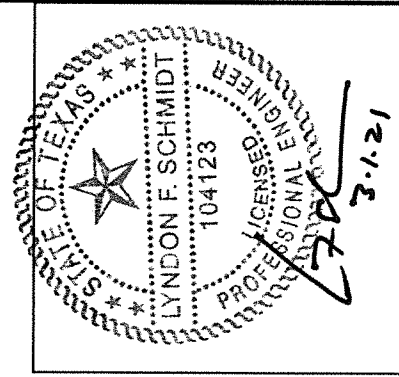

Documents Prepared By: Lyndon F. Schmidt, P.E.
TEXAS P.E. #104123

RW BUILDING CONSULTANTS, INC.
P.O. Box 230 Valrico FL 33595
Phone No.: 813.659.9197

TEXAS BOARD OF PROFESSIONAL ENGINEERS
CERTIFICATE OF REGISTRATION # F-11852

PRODUCT:	THERMA-TRU FIBERGLASS DOOR
PART OR ASSEMBLY:	HARDWARE DETAILS

NO.	DATE	BY	REVISIONS

DATE:	1/06/21
SCALE:	N.T.S.
DWG. BY:	RW
CHK. BY:	LFS
DRAWING NO.:	TX-5138
SHEET	8 OF 9

Z:\Clients\Therma Tru PERMANENT\B - Texas Dept of Ins\TDI - DR XXX - 6'8, 7' & 8' Opaque FG NonImp IS Dir Set Sidelites (TX 5134-5139)\C - Drawings\TX-5138-39.dwg

BILL OF MATERIALS		
ITEM #	DESCRIPTION	MATERIAL
B	2X BUCK (G >= 0.42)	WOOD
C	1/4" MAX. SHIM SPACE	-
D	1/4" PFH DeWALT OR ITW CONCRETE SCREW	STEEL
F	#10 X 2" PFH WOOD SCREW	STEEL
L	#10 X 2-1/2" PFH WOOD SCREW (1.15" MIN. EMBEDMENT)	STEEL
Q	#10 X 3" PFH WOOD SCREW (1.75" MIN. EMBEDMENT)	STEEL
R	3/16" X 3-1/4" ITW CONCRETE SCREW	STEEL
X	2X REINFORCEMENT (SG = 0.55)	WOOD
1	WOOD JAMB (FINGER JOINT PINE)	WOOD
2	COMPOSITE JAMB	COMP
7	WEATHERSTRIP	FOAM
8	DOOR SWEEP	VINYL
10	#10 X 1-1/2" PFH WOOD SCREW	STEEL
11	#12 X 1-1/2" PFH WOOD SCREW	STEEL
22	#8 X 3/4" PFH WOOD SCREW	STEEL
23	#9 X 3/4" PFH WOOD SCREW	STEEL
24	#9 X 1" PFH WOOD SCREW	STEEL
25	#8 X 1-1/2" PFH WOOD SCREW	STEEL
26	#8 X 5/8" PFH WOOD SCREW	STEEL
27	LATCH STRIKE PLATE	STEEL
28	DEADBOLT STRIKE PLATE	STEEL
28A	DEADBOLT SUB STRIKE PLATE	STEEL
29	4" X 4" HINGE	STEEL
32	INSWING THRESHOLD	ALUM/COMP
33	INSWING THRESHOLD w/ SIDELITE ADAPTER	ALUM/COMP
40	DOOR PANEL (BOOK)	-
41	DOOR PANEL (HYBRID)	-
42	DOOR PANEL (U1)	-

CONCRETE ANCHOR NOTES:

- Concrete anchor locations at the corners may be adjusted to maintain the min. edge distance to mortar joints.
- Concrete anchor locations noted as "MAX. ON CENTER" must be adjusted to maintain the min. edge distance to mortar joints, additional concrete anchors may be required to ensure the "MAX. ON CENTER" dimension are not exceeded.
- Concrete anchor table:

ANCHOR TYPE	ANCHOR SIZE	MIN. EMBEDMENT	MIN. CLEARANCE TO MASONRY EDGE	MIN. CLEARANCE TO ADJACENT ANCHOR
ITW TAPCON®	1/4"	1-3/4"	2"	4"
DeWALT ULTRACON®	1/4"	1-3/4"	1"	4"
ITW TAPCON®	3/16"	1-1/4"	3"	1-1/2"

WOOD SCREW INSTALLATION NOTES:

- Maintain a minimum 5/8" edge distance, 1" end distance, & 1" o.c. spacing of wood screws to prevent the splitting of wood.

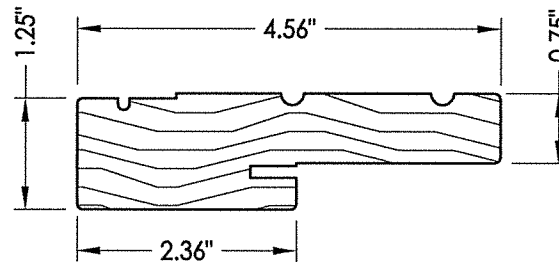

1 WOOD JAMB

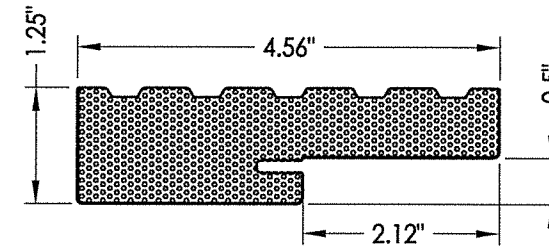

2 COMPOSITE JAMB

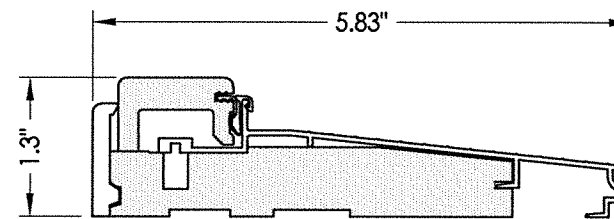

32 INSWING THRESHOLD
Adjustable Composite Sill

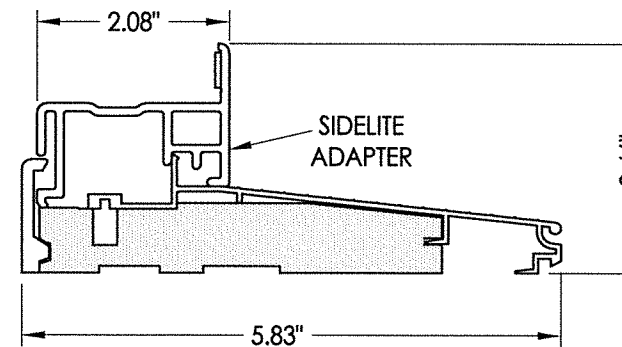

33 INSWING THRESHOLD w/ SIDELITE ADAPTER
Composite Sill

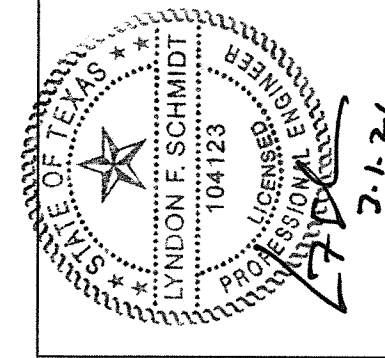

Documents Prepared By: Lyndon F. Schmidt, P.E.
TEXAS P.E. #104123

RW BUILDING CONSULTANTS, INC.
P.O. Box 230 Valrico FL 33595
Phone No.: 813.659.9197

TEXAS BOARD OF PROFESSIONAL ENGINEERS
CERTIFICATE OF REGISTRATION # F-11852

PRODUCT: THERMA-TRU FIBERGLASS DOOR
PART OR ASSEMBLY: BILL OF MATERIALS & COMPONENTS

NO.	DATE	BY	REVISIONS

DATE: 1/06/21
SCALE: N.T.S.
DWG. BY: RW
CHK. BY: LFS
DRAWING NO.: TX-5138
SHEET 9 OF 9