

WINCORE™

WINDOWS & DOORS

250 Staunton Turnpike, Parkersburg, WV 26104

OPAQUE FIBERGLASS DOORS SINGLES w/ or w/o SIDELITES IN SWING / OUT SWING "IMPACT"

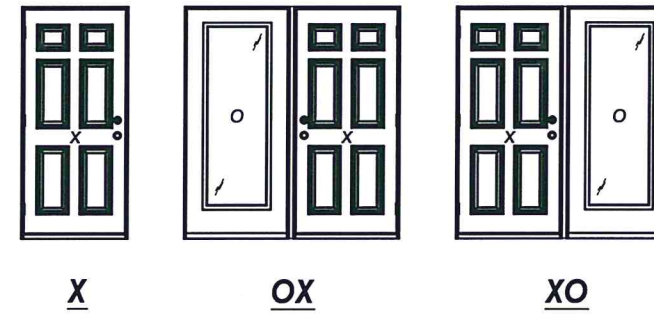
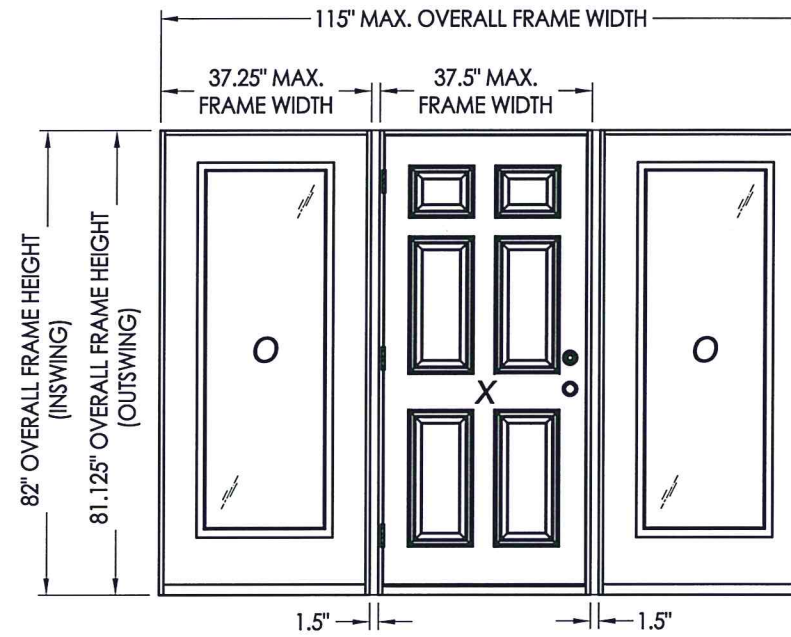

EVALUATED FOR USE IN THE STATE OF TEXAS

The Fiberglass Door system described herein complies with the 2018 International Residential Code (IRC), Sections R301 & R609 and the 2018 International Building Code (IBC), Sections 1404.13, 1609, 1709.5, 2403 and 2404 subject to the following conditions:

1. Anchors shall be as listed and spaced as shown in the details. Anchor embedment to base material shall be beyond wall dressing or stucco.
2. This system has been tested and evaluated as a large missile impact protective system for installation in the Seaward, Inland I and Inland II areas. This product meets missile level "D" as defined in ASTM E 1996.
3. Allowable design pressure requirements must be equal to or less than the design pressure rating shown in the design pressure chart, sheet 1 of this drawing.
4. Conditions not covered by this drawing are subject to further engineering analysis.

TABLE OF CONTENTS	
SHEET #	DESCRIPTION
1	Typical Elevations, Design Pressures & General Notes
2	Door Panel Details
3	Sidelite Panel Details
4	Elevations
5	Horizontal Cross Sections
6	Horizontal & Vertical Cross Sections
7	Vertical Cross Sections
8	Frame Anchoring & Hardware Details
9	Bill of Materials & Components

CONFIGURATION	MAX. FRAME DIMENSION	DESIGN PRESSURE (PSF) IN SWING		DESIGN PRESSURE (PSF) OUT SWING	
		POSITIVE	NEGATIVE	POSITIVE	NEGATIVE
X	37.5" x 82"	+50.0	-50.0	+50.0	-50.0
OX/XO	76.25" x 82"	+50.0	-50.0	+50.0	-50.0
OXO	115" x 82"	+50.0	-50.0	+50.0	-50.0



Documents Prepared By: Lyndon F. Schmidt, P.E.
TEXAS P.E. #104123

RW BUILDING CONSULTANTS, INC.
P.O. Box 230 Valrico FL, 33595
Phone No.: 813.659.9197

TEXAS BOARD OF PROFESSIONAL ENGINEERS
CERTIFICATE OF REGISTRATION # F-11852

PRODUCT: WINCORE FIBERGLASS ENTRY DOOR "Impact"

PART OR ASSEMBLY: TYPICAL ELEVATION, DESIGN PRESSURES & GENERAL NOTES

NO.	DATE	BY	REVISIONS

DATE: 12/4/19

SCALE: N.T.S.

DWG. BY: RW

CHK. BY: LFS

DRAWING NO.: TX-4960

SHEET 1 OF 9

R:\Clients\Wincore PERMANENT\B - Texas Dept of Ins\Doors\TDI XXX - OP FG Door, Impact\C - Drawings\TX-4960.61.dwg, 2.1

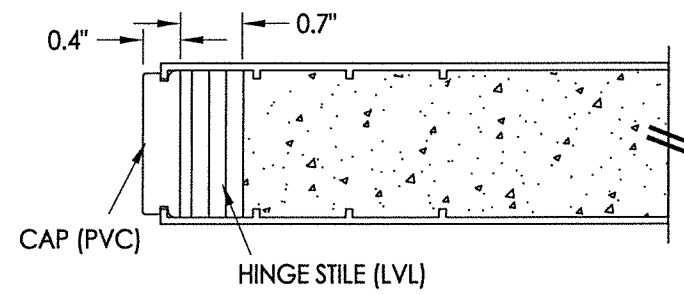

EXTERIOR

INTERIOR

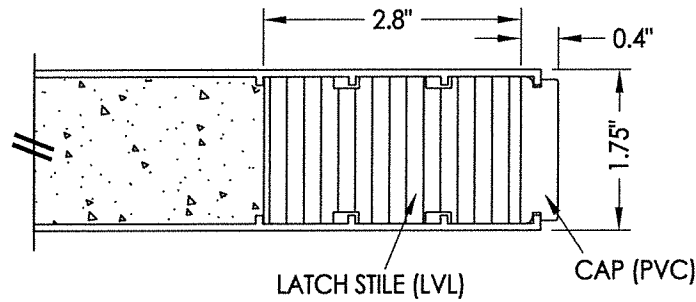

1
2 **HORIZONTAL CROSS SECTION**

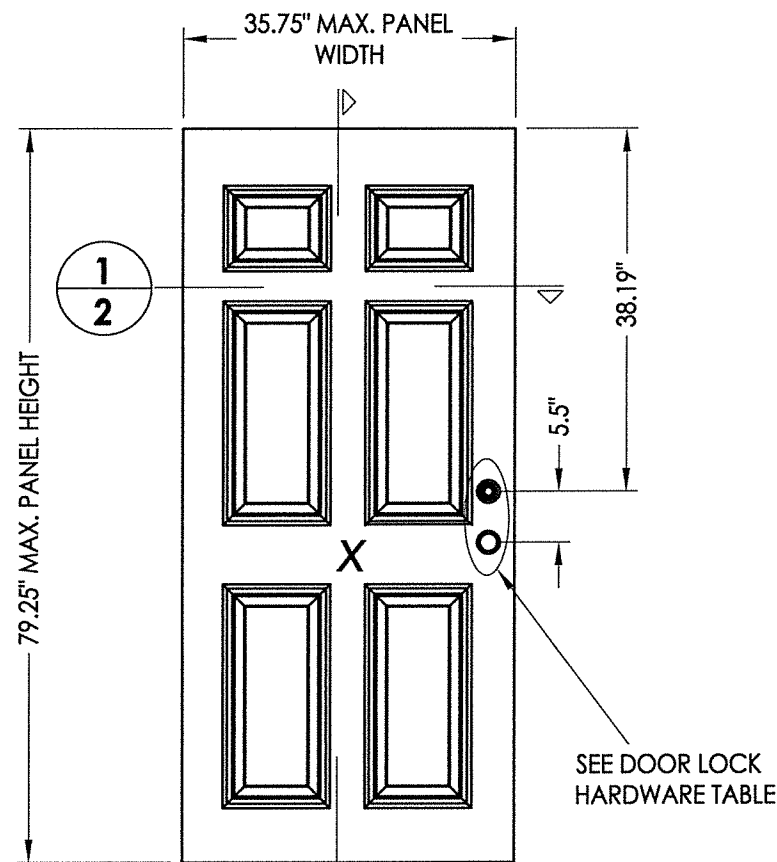

40 **PLASTPRO DOOR PANEL**

DOOR LOCK HARDWARE TABLE	
MANUFACTURER	MODEL
ENDURA	TRILENNIUM 3000 SERIES MULTI-POINT LOCK (3 pt.)
SCHLAGE	KNOB: "F" SERIES (F60) DEADBOLT: "B" SERIES (B60/62)
KWSIKSET	KNOB: SERIES (400) DEADBOLT: SERIES (660)

FIBERGLASS SKIN: 0.075" MIN. THK.
FOAM CORE: POLYURETHANE - 1.9 PCF MIN.)

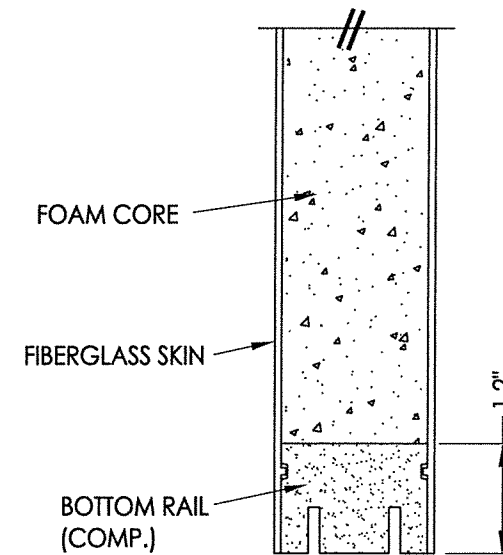
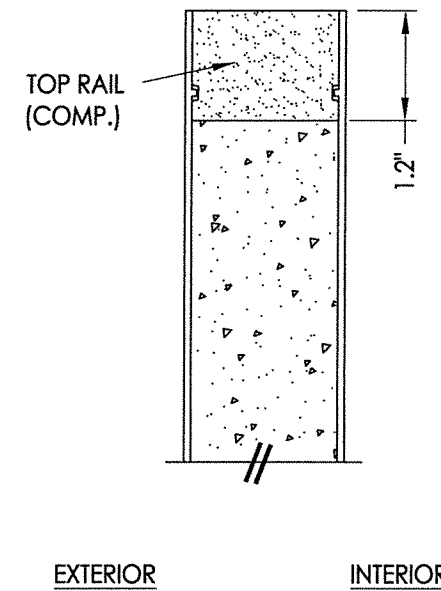

2
2 **VERTICAL CROSS SECTION**

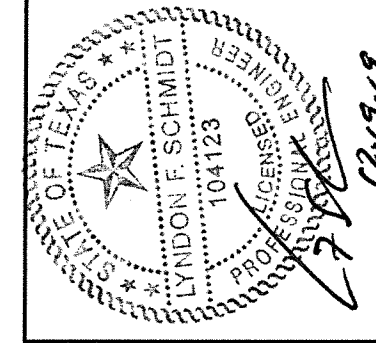

Documents Prepared By: Lyndon F. Schmidt, P.E.
TEXAS P.E. #104123

RW BUILDING CONSULTANTS, INC.
P.O. Box 230 Vairico FL 33595
Phone No.: 813.659.9197
TEXAS BOARD OF PROFESSIONAL ENGINEERS
CERTIFICATE OF REGISTRATION # F-11852

PRODUCT:	WINCORE FIBERGLASS ENTRY DOOR "Impact"
PART OR ASSEMBLY:	DOOR PANEL DETAILS

NO.	DATE	BY

DATE:	12/4/19
SCALE:	N.T.S.
DWG. BY:	RW
CHK. BY:	LFS
DRAWING NO.:	TX-4960
SHEET	2 of 9

R:\Clients\Wincore PERMANENT\B - Texas Dept of Ins\Doors\TDI XXX - OP FG Door, Impact\C - Drawings\TX-4960.61.dwg, 3.1

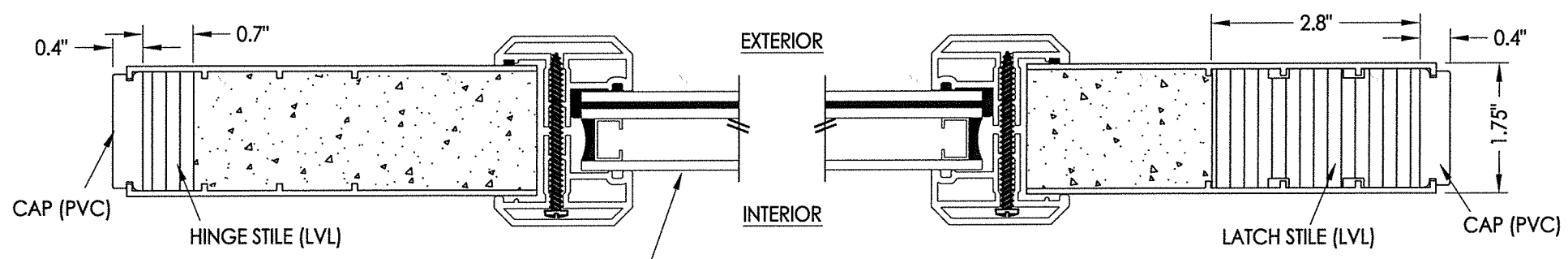

1
3
HORIZONTAL CROSS SECTION

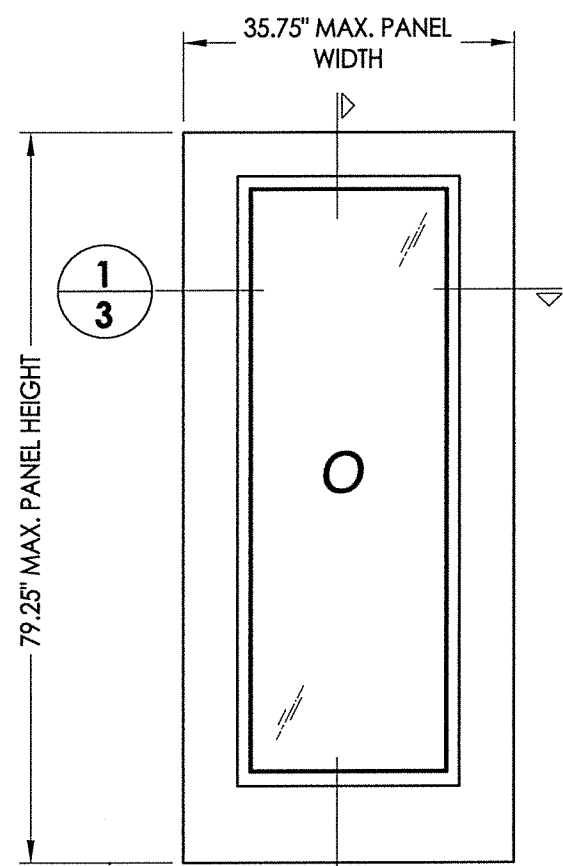

50 **PLASTPRO SIDELITE PANEL**

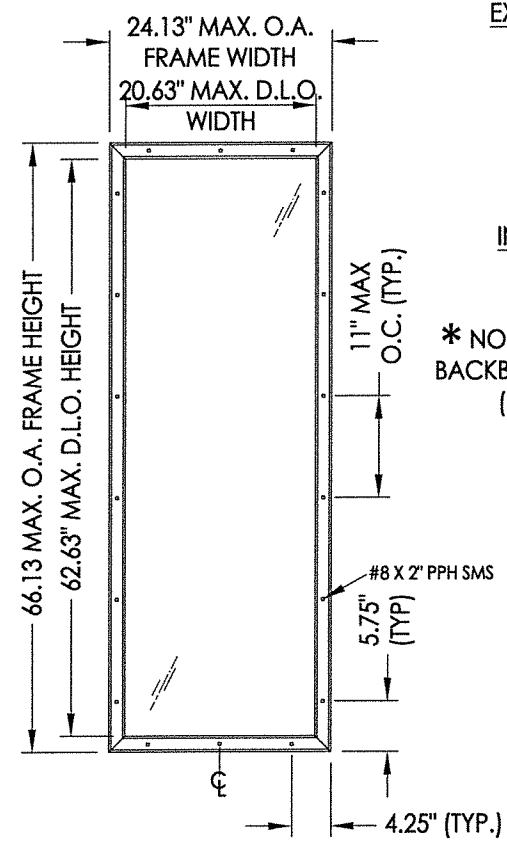

**ODL LITE FRAME DETAIL
'FLAT FRAME' PROFILE**

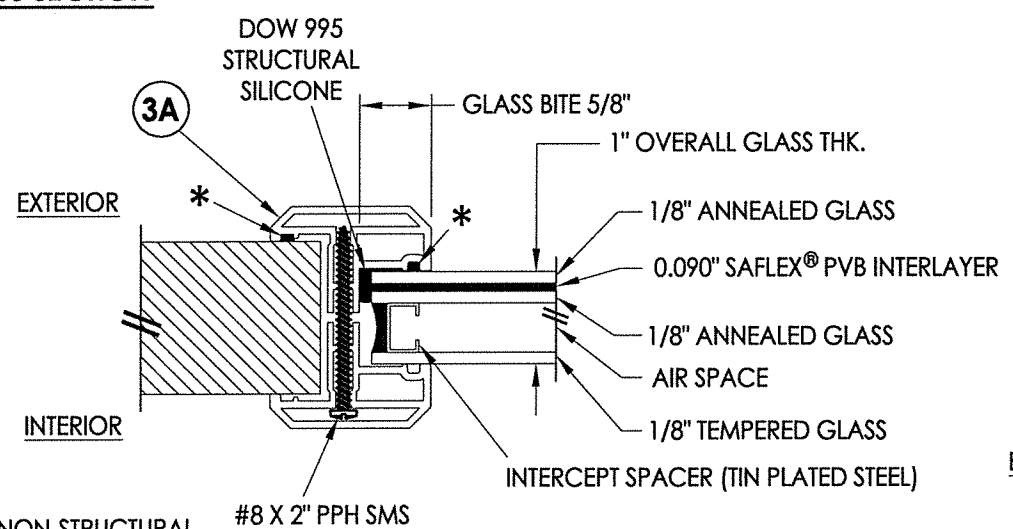

G1 **GLAZING DETAIL
ODL 'FLAT FRAME'**

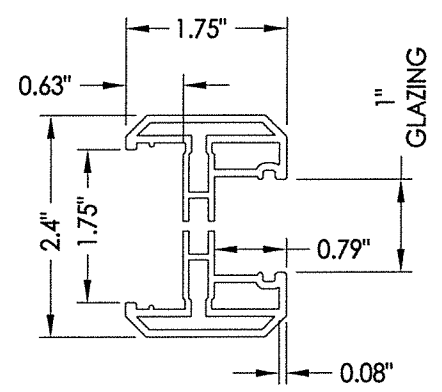

3A **ODL LITE FRAME
'FLAT FRAME' PROFILE
(6063-T5 ALUM)**

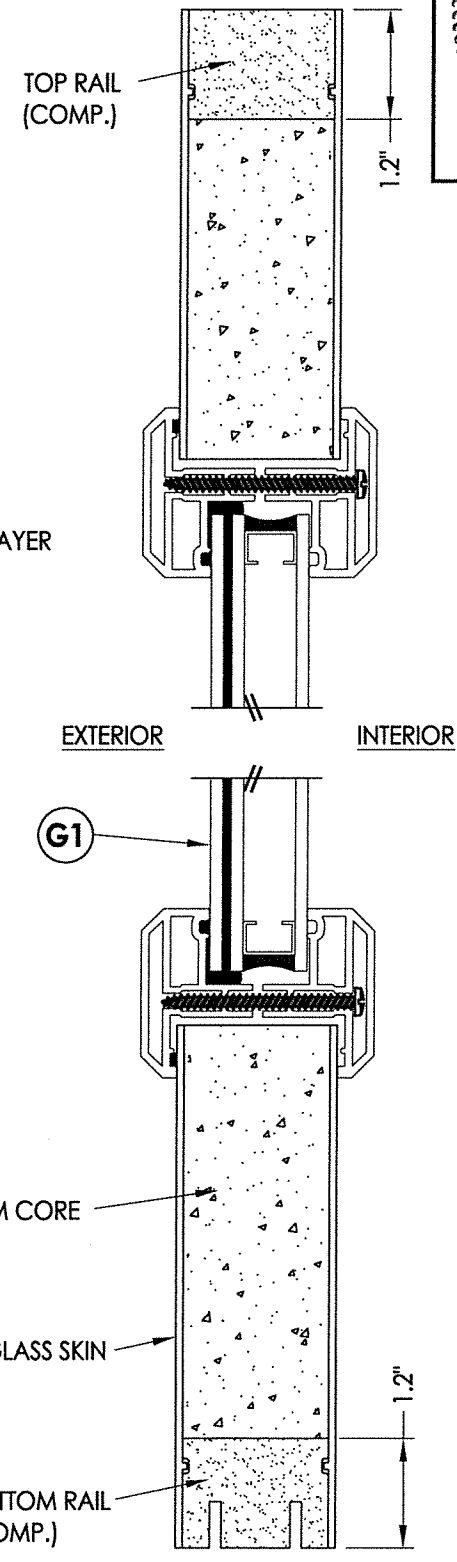

2
3
VERTICAL CROSS SECTION

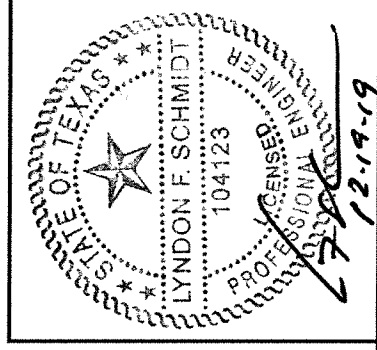

Documents Prepared By: Lyndon F. Schmidt, P.E.
TEXAS P.E. #104123

RW BUILDING CONSULTANTS, INC.
P.O. Box 230 Valrico FL 33595
Phone No.: 813.659.9197

TEXAS BOARD OF PROFESSIONAL ENGINEERS
CERTIFICATE OF REGISTRATION # F-11852

PRODUCT: WINCORE
FIBERGLASS ENTRY DOOR
"Impact"

PART OR ASSEMBLY:
LITE FRAME
GLAZING DETAILS

NO.	DATE	BY	REVISIONS

DATE: 12/4/19
SCALE: N.T.S.
DWG. BY: RW
CHK. BY: LFS
DRAWING NO.: TX-4960
SHEET 3 OF 9

FIBERGLASS SKIN: 0.075" MIN. THK.
FOAM CORE: POLYURETHANE - 1.9 PCF MIN.)

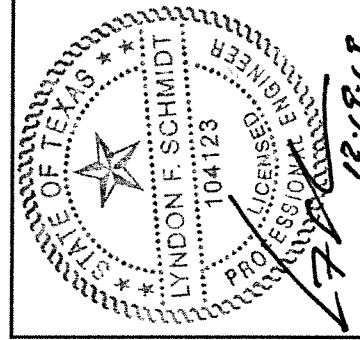
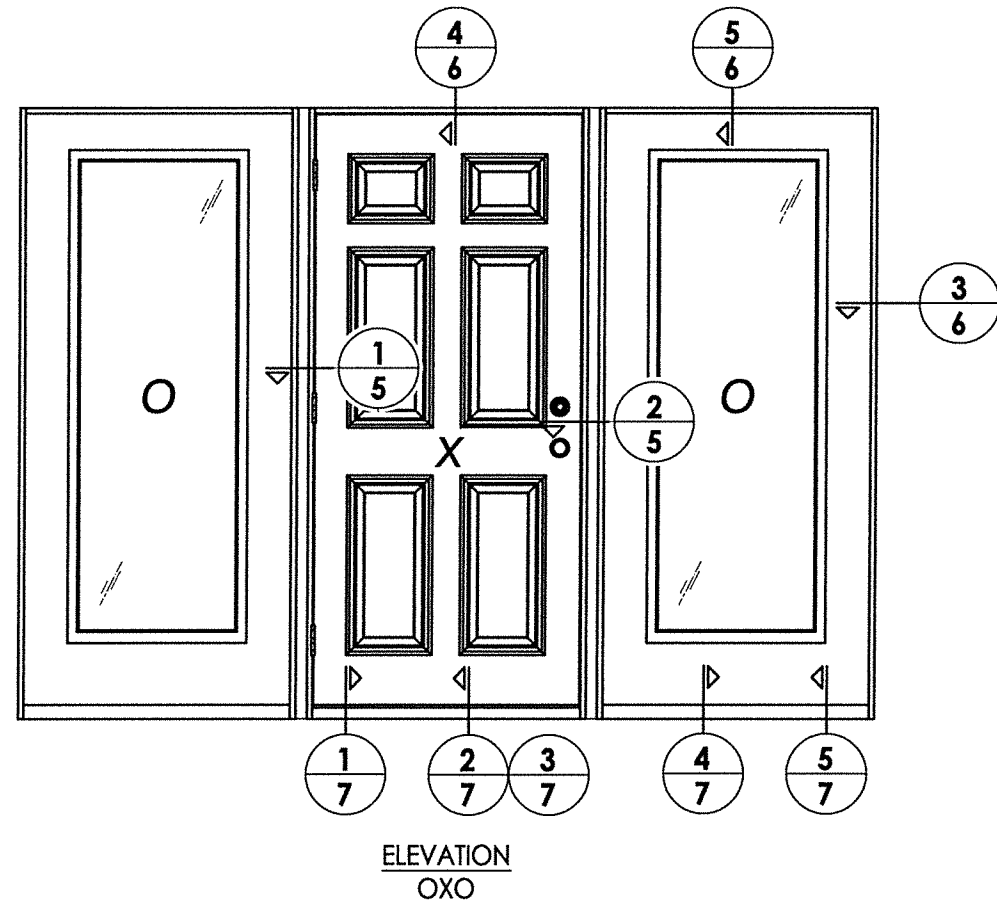
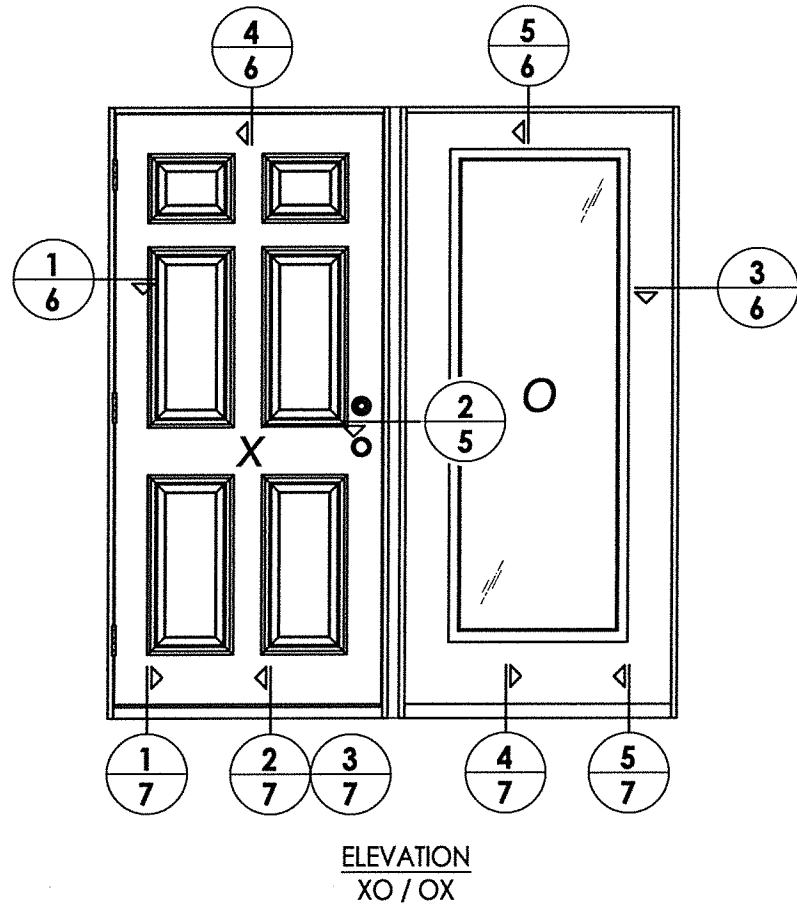
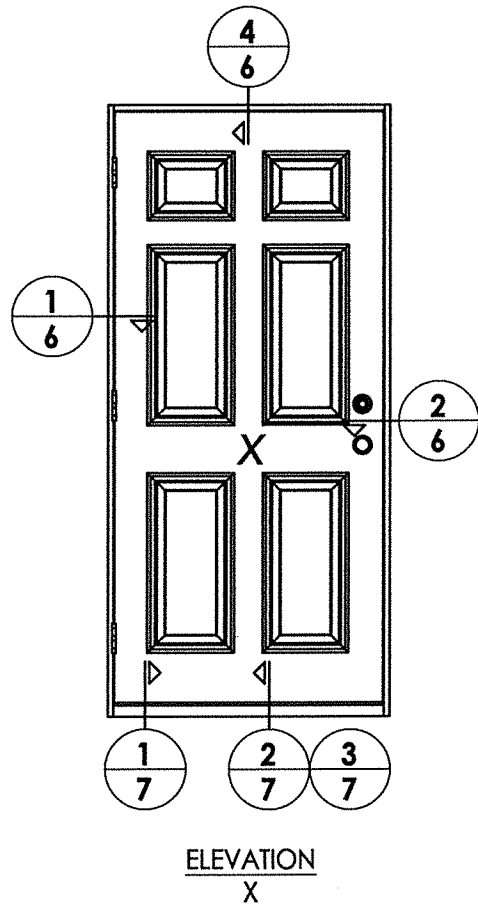

Documents Prepared By: Lyndon F. Schmidt, P.E.
TEXAS P.E. #104123

RW BUILDING CONSULTANTS, INC.
P.O. Box 230 Vairico FL 33595
Phone No.: 813.659.9197

TEXAS BOARD OF PROFESSIONAL ENGINEERS
CERTIFICATE OF REGISTRATION # F-11852

PRODUCT: WINCORE FIBERGLASS ENTRY DOOR "Impact"	
PART OR ASSEMBLY: ELEVATIONS	
	BY
	NO. DATE
REVISIONS	
DATE: 12/4/19	
SCALE: N.T.S.	
DWG. BY: RW	
CHK. BY: LFS	
DRAWING NO.: TX-4960	
SHEET 4 OF 9	

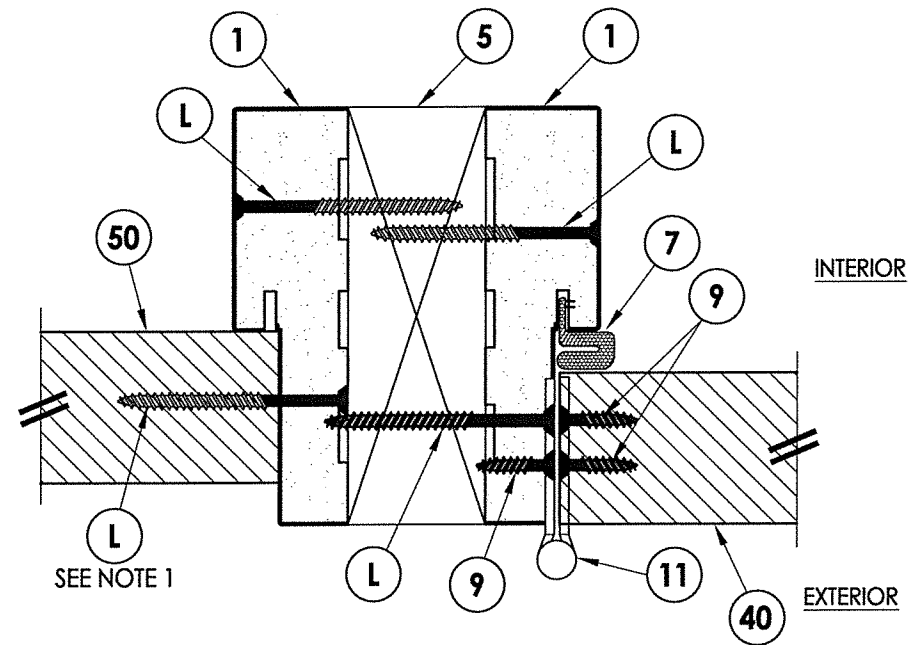

1 HORIZONTAL CROSS SECTION
5 Outswing shown (Inswing similar)
 2X Jamb Reinforcement

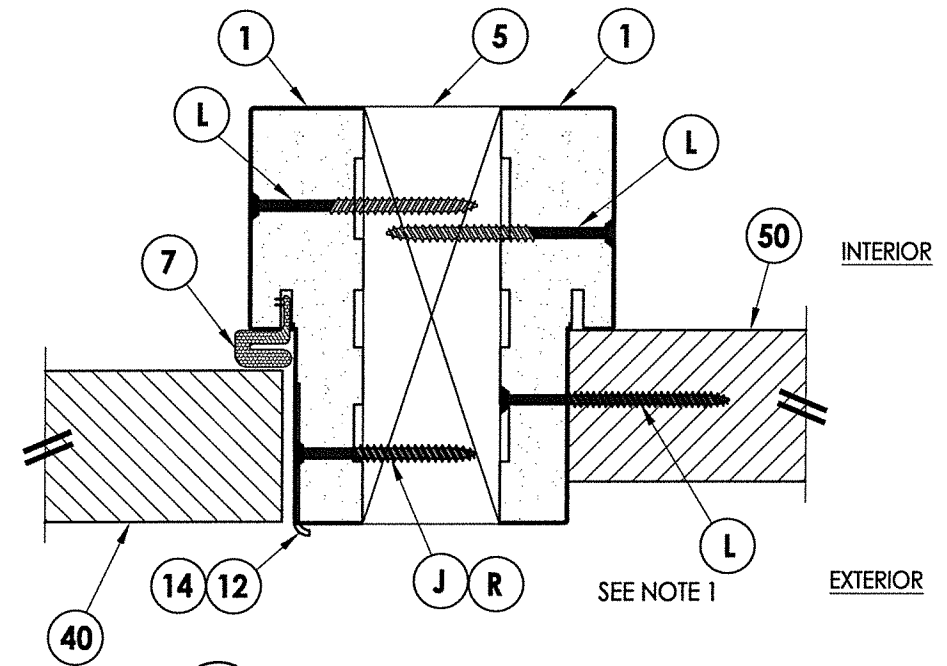

2 HORIZONTAL CROSS SECTION
5 Outswing shown (Inswing similar)
 2X Jamb Reinforcement

NOTE:
 1. Spacing for item L: 6" from each end and 3 more equally spaced along sidelite jamb (5 total).

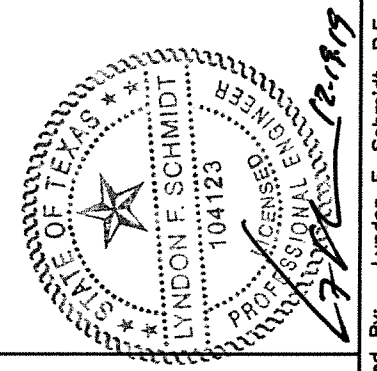

Documents Prepared By: Lyndon F. Schmidt, P.E.
 TEXAS P.E. #104123
RW BUILDING CONSULTANTS, INC.
 P.O. Box 230 Vairico FL 33595
 Phone No.: 813.659.9197
 TEXAS BOARD OF PROFESSIONAL ENGINEERS
 CERTIFICATE OF REGISTRATION # F-11852

PRODUCT: WINCORE
 FIBERGLASS ENTRY DOOR
 "Impact"
 PART OR ASSEMBLY:
 HORIZONTAL
 CROSS SECTIONS

NO.	DATE	BY	REVISIONS

DATE: 12/4/19
 SCALE: N.T.S.
 DWG. BY: RW
 CHK. BY: LFS
 DRAWING NO.: TX-4960
 SHEET 5 of 9

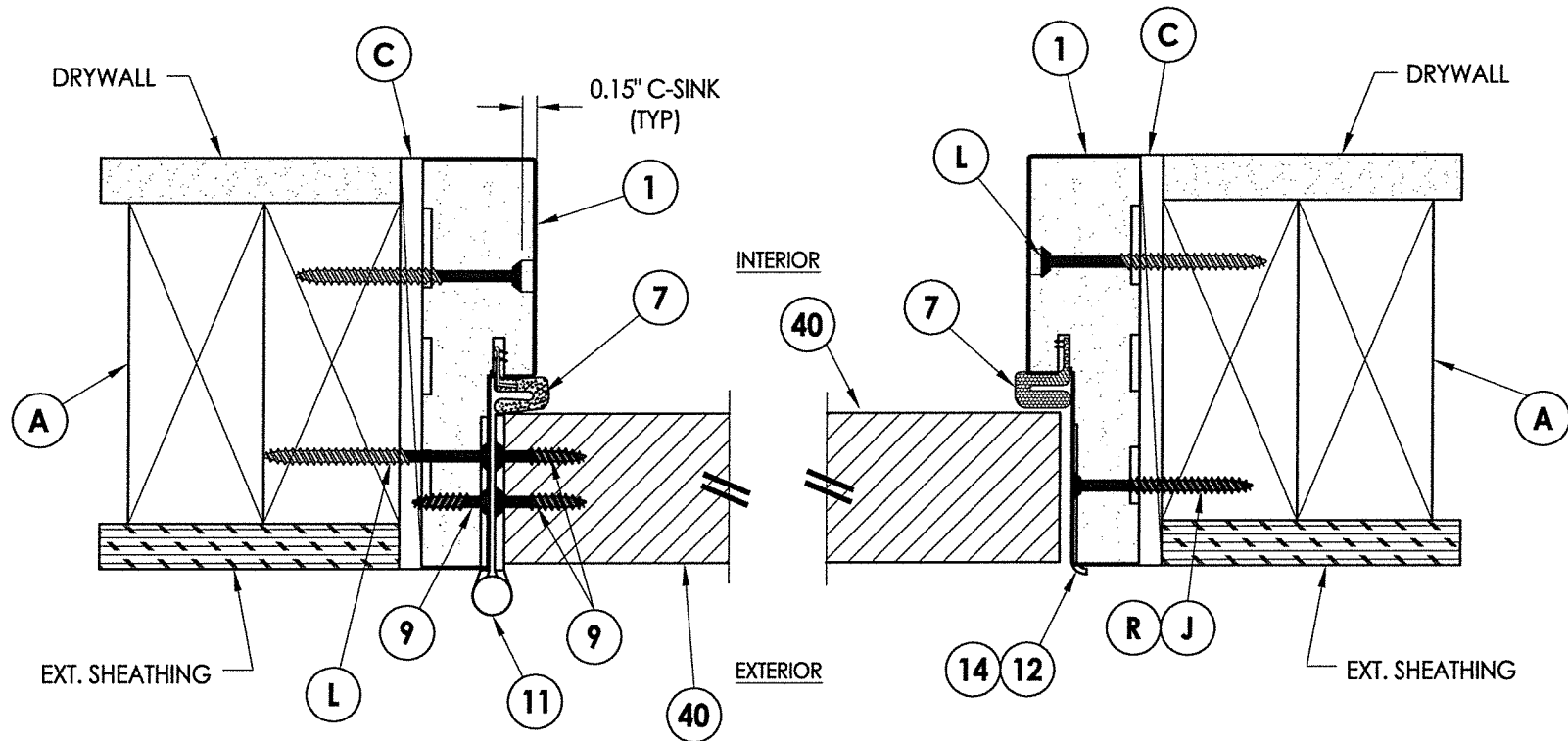

1 HORIZONTAL CROSS SECTION
6 Outswing shown (Inswing similar)

2 HORIZONTAL CROSS SECTION
6 Outswing shown (Inswing similar)

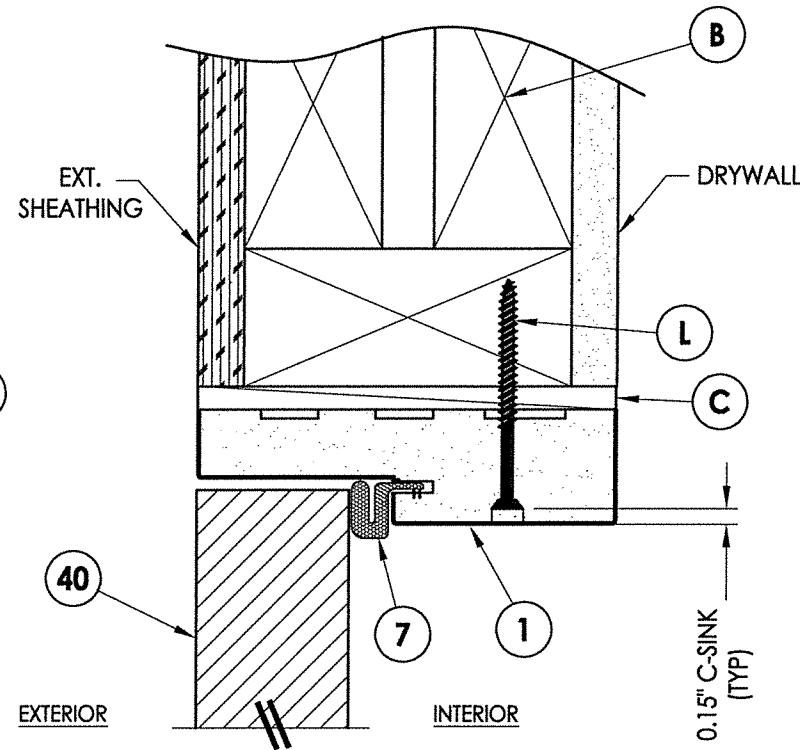

4 VERTICAL CROSS SECTION
6 Outswing shown (Inswing similar)

- NOTES:**
- Spacing for item L: 6" from each end and 3 more equally spaced along sidelite jamb (5 total).
 - Spacing for item L @ head & sill: 6" from each end, 1 @ centerline, 2 additional at 3" & 4.5" from end adjacent to door.

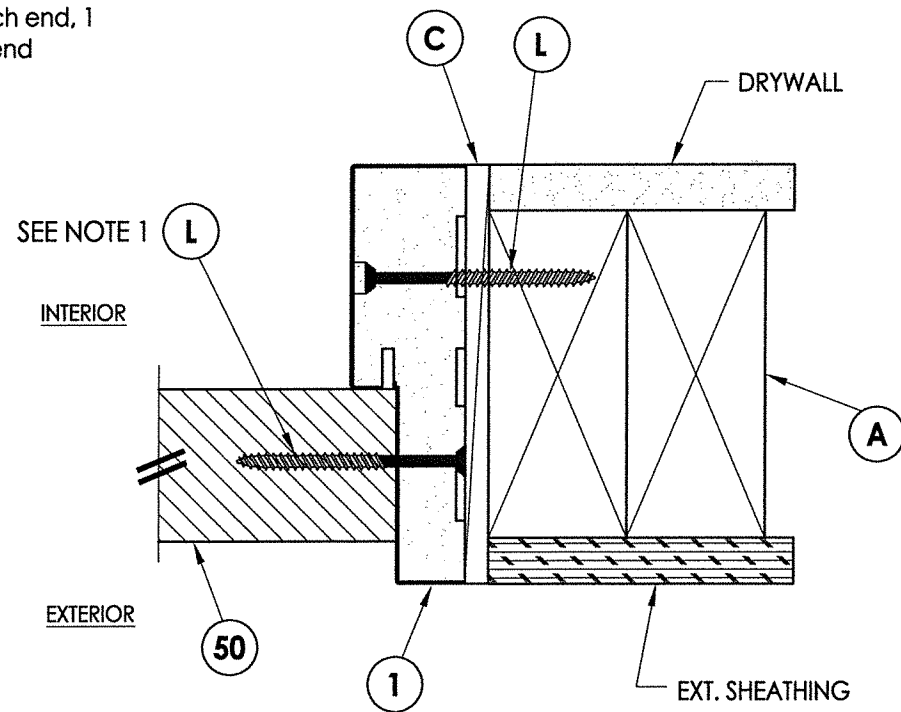

3 HORIZONTAL CROSS SECTION
6 Outswing shown (Inswing similar)

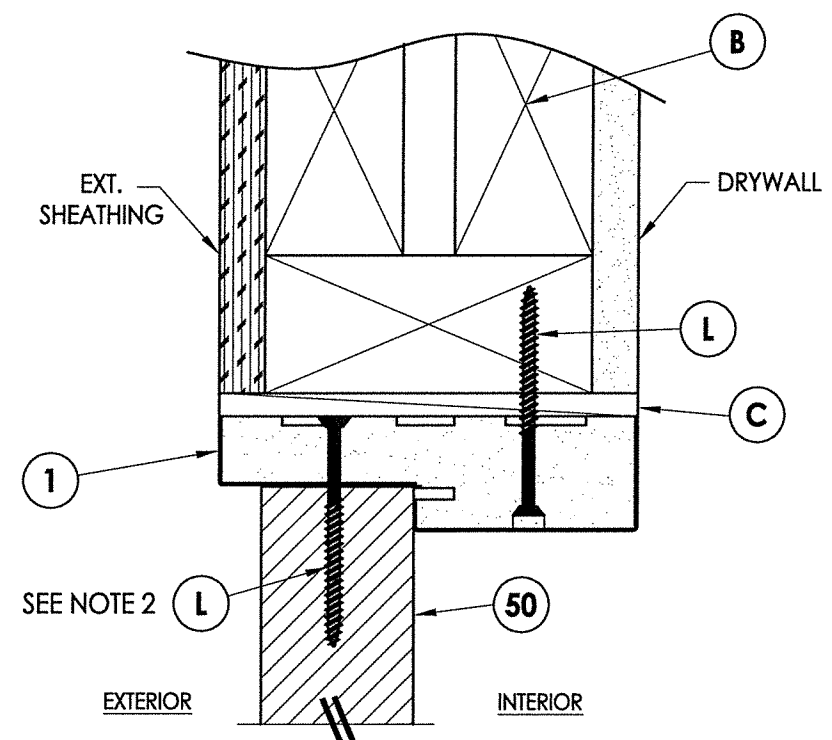

5 VERTICAL CROSS SECTION
6 Outswing shown (Inswing similar)

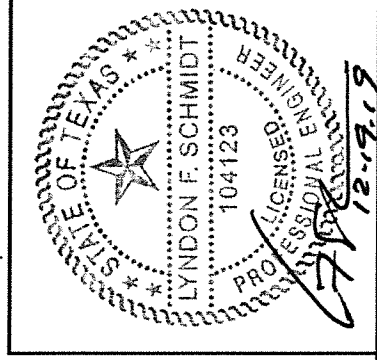

Documents Prepared By: Lyndon F. Schmidt, P.E.
TEXAS P.E. #104123

RW BUILDING CONSULTANTS, INC.
P.O. Box 230 Valrico FL 33595
Phone No.: 813.659.9197

TEXAS BOARD OF PROFESSIONAL ENGINEERS
CERTIFICATE OF REGISTRATION # F-11852

PRODUCT: WINCORE
FIBERGLASS ENTRY DOOR
"Impact"

PART OR ASSEMBLY:
HORIZONTAL & VERTICAL
CROSS SECTIONS

NO.	DATE	BY	REVISIONS

DATE: 12/4/19
SCALE: N.T.S.
DWG. BY: RW
CHK. BY: LFS
DRAWING NO.: TX-4960
SHEET 6 OF 9

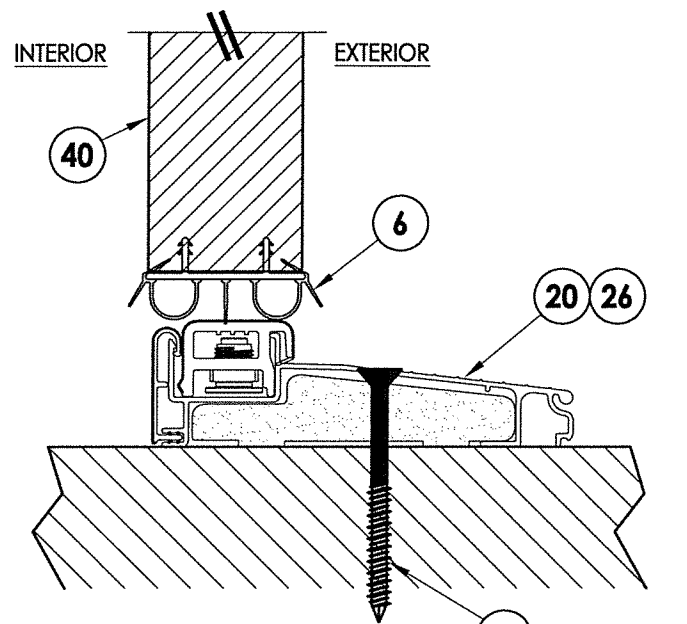

1 VERTICAL CROSS SECTION
7 Inswing sill

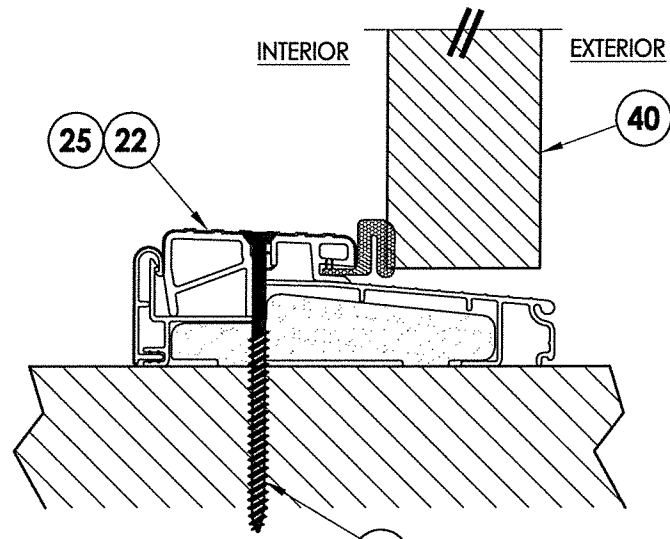

2 VERTICAL CROSS SECTION
7 Outswing sill

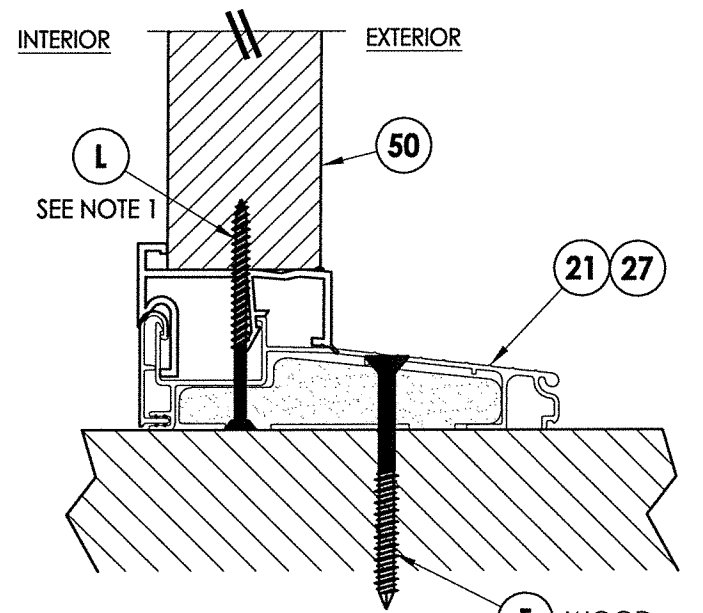

4 VERTICAL CROSS SECTION
7 Inswing sill

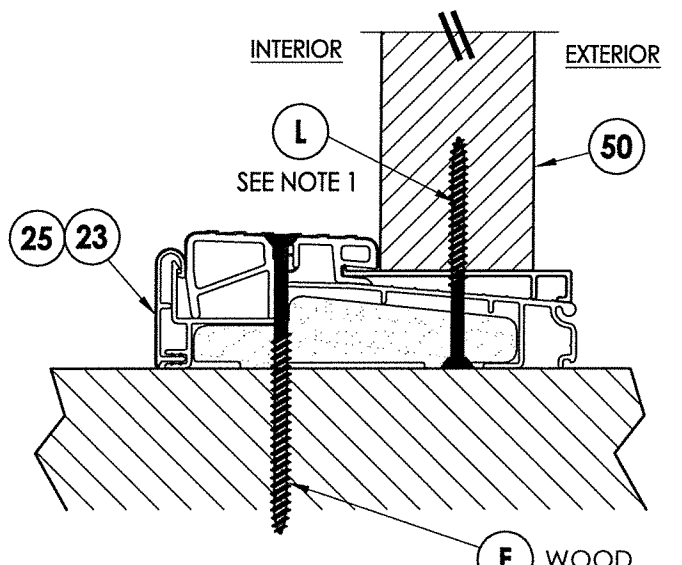

5 VERTICAL CROSS SECTION
7 Inswing sill

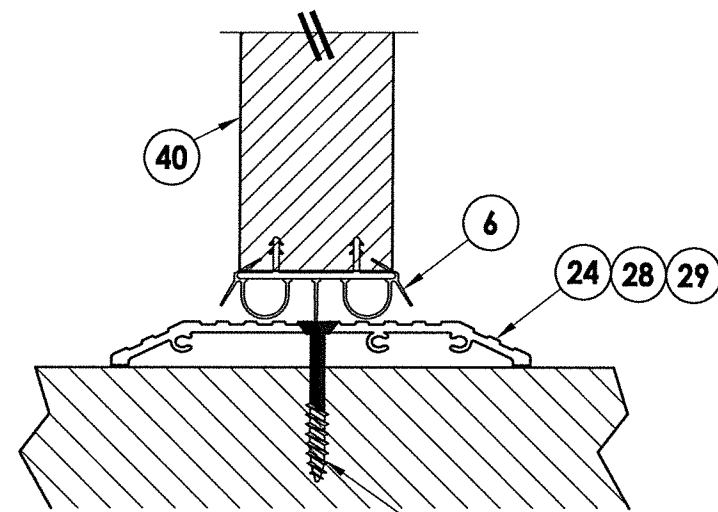

3 VERTICAL CROSS SECTION
7 ADA Sill

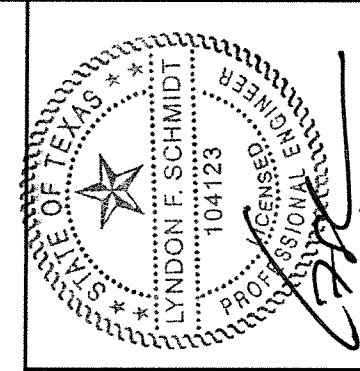

Documents Prepared By: Lyndon F. Schmidt, P.E.
TEXAS P.E. #104123

RW BUILDING CONSULTANTS, INC.
P.O. Box 230 Valrico FL, 33595
Phone No.: 813.659.9197

TEXAS BOARD OF PROFESSIONAL ENGINEERS
CERTIFICATE OF REGISTRATION # F-11852

PRODUCT: WINCORE
FIBERGLASS ENTRY DOOR
"Impact"

PART OR ASSEMBLY:
VERTICAL CROSS
SECTIONS

NO.	DATE	BY	REVISIONS

DATE: 12/4/19
SCALE: N.T.S.
DWG. BY: RW
CHK. BY: LFS
DRAWING NO.: TX-4960
SHEET 7 OF 9

NOTE:
1. Spacing for item L @ head & sill: 6" from each end,
1 @ centerline, 2 additional at 3" & 4.5" from end
adjacent to door.

R:\Clients\Wincore PERMANENT\B - Texas Dept of Ins\Doors\TDI XXX - OP FG Door, ImpactC - Drawings\TX-4960.61.dwg, 8.1

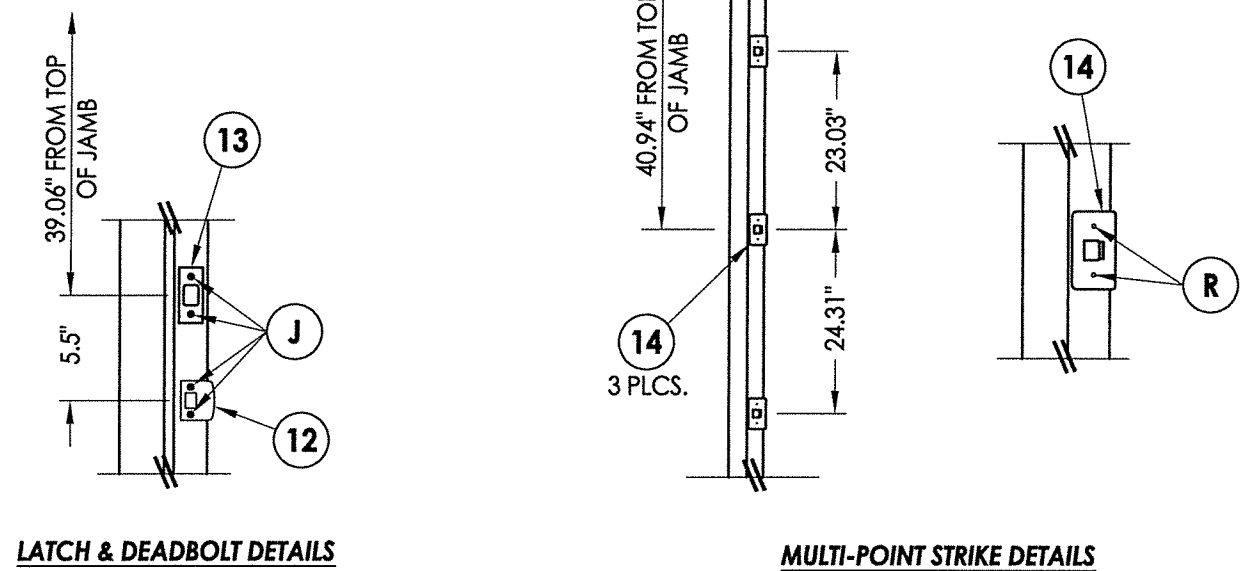
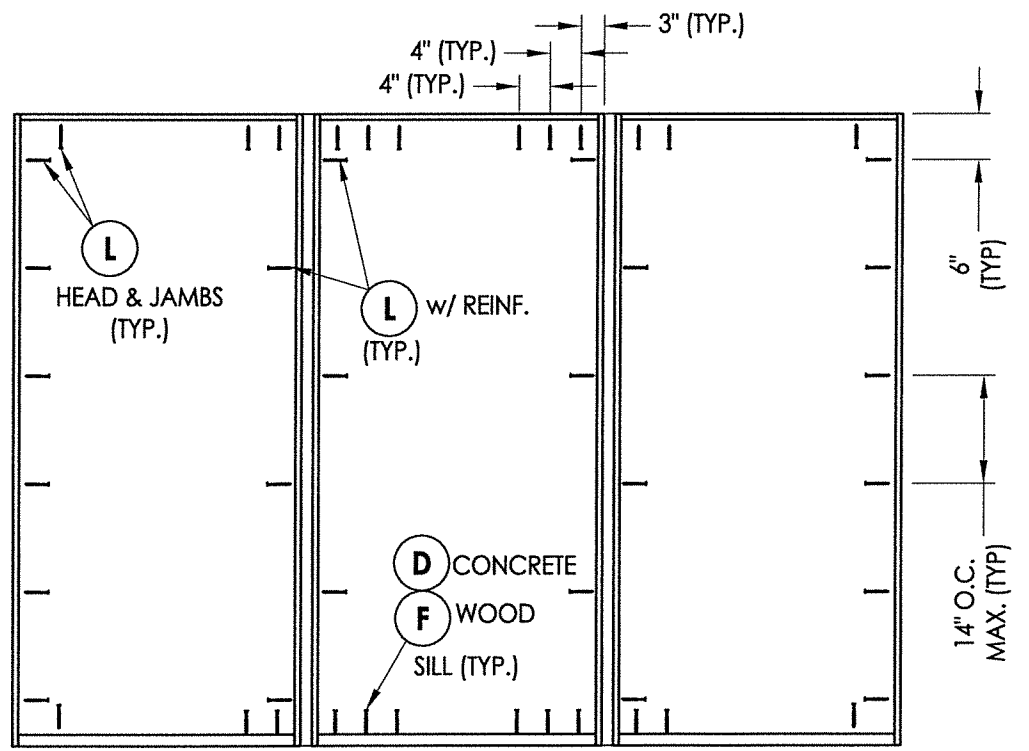
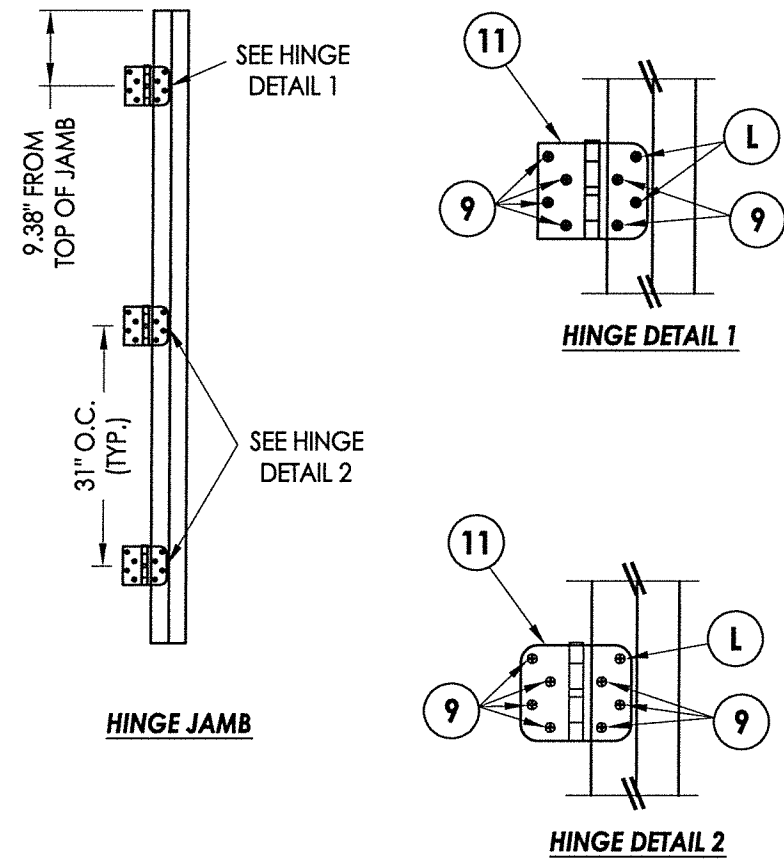
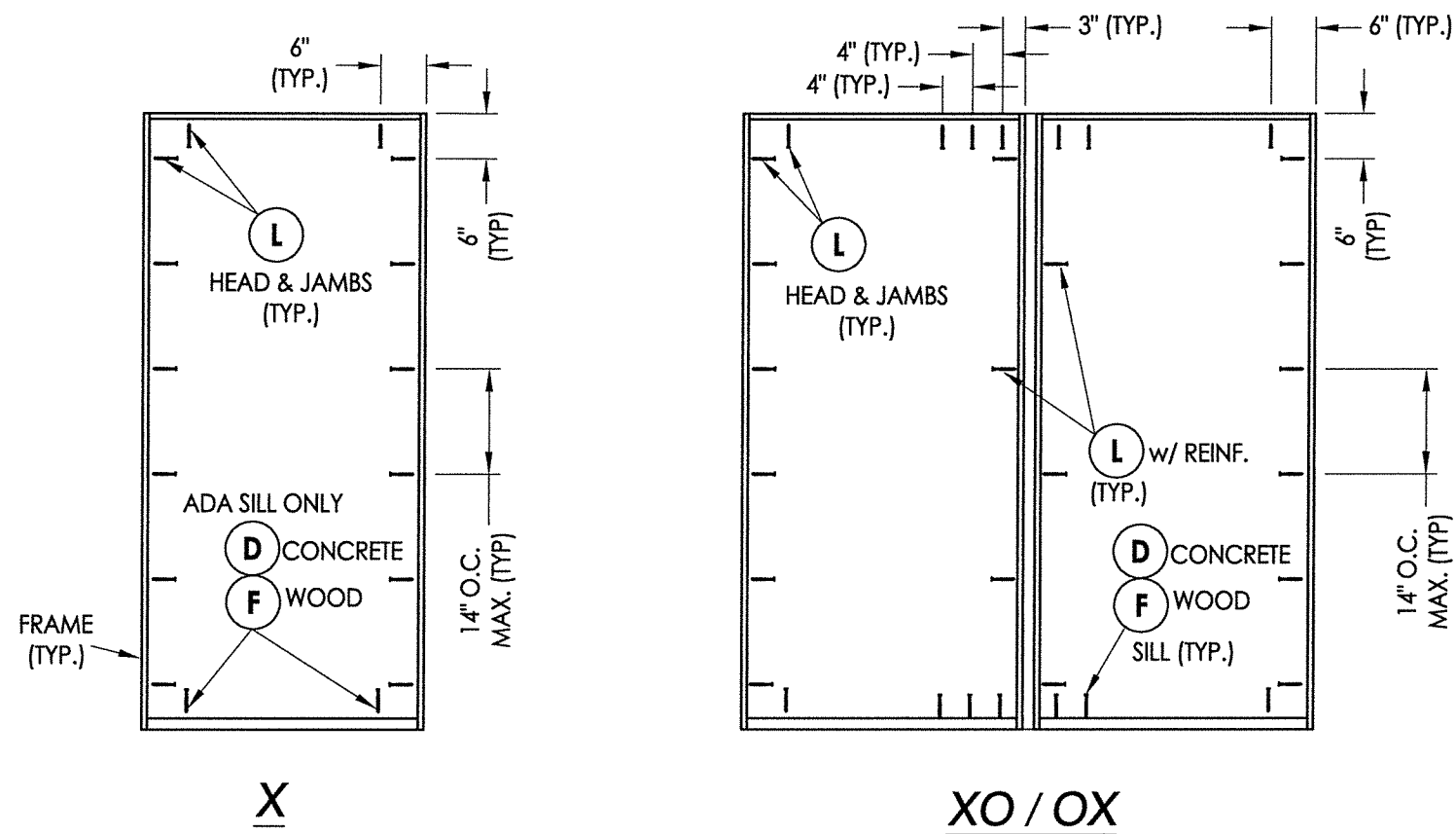

OXO
FRAME ANCHORING

HARDWARE DETAILS

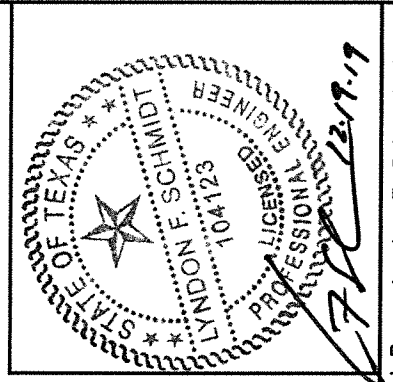

Documents Prepared By: Lyndon F. Schmidt, P.E.
TEXAS P.E. #104123

RW BUILDING CONSULTANTS, INC.
P.O. Box 230 Valrico FL, 33595
Phone No.: 813.659.9197

TEXAS BOARD OF PROFESSIONAL ENGINEERS
CERTIFICATE OF REGISTRATION # F-11852

PRODUCT: WINCORE
FIBERGLASS ENTRY DOOR
"Impact"

PART OR ASSEMBLY:
FRAME ANCHORING
& HARDWARE DETAILS

NO.	DATE	BY	REVISIONS

DATE: 12/4/19
SCALE: N.T.S.
DWG. BY: RW
CHK. BY: LFS
DRAWING NO.: TX-4960
SHEET 8 OF 9

