

REVISIONS			
REV	DESCRIPTION	DATE	APPROVED
A	REVISED PER NEW CODE	02/11/2021	R.L.

NOTES:

1. THE PRODUCT SHOWN HEREIN IS DESIGNED AND MANUFACTURED TO COMPLY WITH REQUIREMENTS OF 2018 IBC AND 2018 IRC.
2. WOOD FRAMING AND MASONRY OPENING TO BE DESIGNED AND ANCHORED TO PROPERLY TRANSFER ALL LOADS TO STRUCTURE. FRAMING AND MASONRY OPENING IS THE RESPONSIBILITY OF THE ARCHITECT OR ENGINEER OF RECORD.
3. 1X BUCK OVER MASONRY/CONCRETE IS OPTIONAL.
4. WHERE SHIM OR BUCK THICKNESS IS LESS THAN 1-1/2" UNITS MUST BE ANCHORED THROUGH THE FRAME IN ACCORDANCE WITH MANUFACTURER'S PUBLISHED INSTALLATION INSTRUCTIONS. ANCHORS SHALL BE SECURELY FASTENED DIRECTLY INTO MASONRY, CONCRETE OR OTHER STRUCTURAL SUBSTRATE MATERIAL.
5. WHERE WOOD BUCK THICKNESS IS 1-1/2" OR GREATER, BUCK SHALL BE SECURELY FASTENED TO MASONRY, CONCRETE OR OTHER STRUCTURAL SUBSTRATE. UNITS MAY BE ANCHORED THROUGH FRAME TO SECURED WOOD BUCK IN ACCORDANCE WITH MANUFACTURER'S PUBLISHED INSTALLATION INSTRUCTIONS.
6. WHERE 1X BUCK IS NOT USED DISSIMILAR MATERIALS MUST BE SEPARATED WITH APPROVED COATING OR MEMBRANE. SELECTION OF COATING OR MEMBRANE IS THE RESPONSIBILITY OF THE ARCHITECT OR ENGINEER OF RECORD.
7. BUCKS SHALL EXTEND BEYOND UNIT FRAME INTERIOR FACE SO THAT FULL FRAME SUPPORT IS PROVIDED.
8. SHIM AS REQUIRED AT EACH ANCHOR LOCATION WITH LOAD BEARING SHIM. SHIM WHERE SPACE OF 1/16" OR GREATER OCCURS. MAXIMUM ALLOWABLE SHIM STACK TO BE 1/4".
9. SHIMS SHALL BE LOCATED, APPLIED AND MADE FROM MATERIALS AND THICKNESS CAPABLE OF SUSTAINING APPLICABLE LOADS.
10. WIND LOAD DURATION FACTOR Cd=1.6 WAS USED FOR WOOD ANCHOR CALCULATIONS.
11. FRAME MATERIAL: FOAM PVC CO-EX.
12. UNITS MUST BE GLAZED PER ASTM E1300, SEE SHEET 2 FOR GLASS DETAILS.
13. APPROVED IMPACT PROTECTIVE SYSTEM IS NOT REQUIRED FOR THIS PRODUCT IN WIND BORNE DEBRIS REGIONS.
14. FOR ANCHORING THROUGH FRAME INTO WOOD FRAMING OR 2X BUCK USE #10 WOOD SCREWS WITH SUFFICIENT LENGTH TO ACHIEVE A 1 1/4" MINIMUM EMBEDMENT INTO SUBSTRATE. LOCATE ANCHORS AS SHOWN IN ELEVATIONS AND INSTALLATION DETAILS.

15. FOR ANCHORING THROUGH FRAME INTO MASONRY/CONCRETE USE 1/4" TAPCONS WITH SUFFICIENT LENGTH TO ACHIEVE A 1 1/4" MINIMUM EMBEDMENT INTO SUBSTRATE WITH 2" MINIMUM EDGE DISTANCE. LOCATE ANCHORS AS SHOWN IN ELEVATIONS AND INSTALLATION DETAILS.
16. FOR ANCHORING THROUGH FRAME INTO METAL STRUCTURE USE #10 SMS OR SELF DRILLING SCREWS WITH SUFFICIENT LENGTH TO ACHIEVE 3 THREADS MINIMUM BEYOND STRUCTURE INTERIOR WALL. LOCATE ANCHORS AS SHOWN IN ELEVATIONS AND INSTALLATION DETAILS.
17. ALL FASTENERS TO BE CORROSION RESISTANT.
18. INSTALLATION ANCHORS SHALL BE INSTALLED IN ACCORDANCE WITH ANCHOR MANUFACTURER'S INSTALLATION INSTRUCTIONS AND ANCHORS SHALL NOT BE USED IN SUBSTRATES WITH STRENGTHS LESS THAN THE MINIMUM STRENGTH SPECIFIED BELOW:
  - A. WOOD: MINIMUM SPECIFIC GRAVITY OF G=0.42
  - B. CONCRETE: MINIMUM COMPRESSIVE STRENGTH OF 2,000 PSI.
  - C. MASONRY: HOLLOW/FILLED BLOCK PER ASTM C90 WITH Fm=2,000PSI MINIMUM.
  - D. METAL STRUCTURE: STEEL 18GA (.048") FY=33KSI/FU=52KSI OR ALUMINUM 6063-T5 FU=30KSI .125" THICK MINIMUM

TABLE OF CONTENTS	
SHEET NO.	DESCRIPTION
1	NOTES
2	ELEVATION AND GLAZING DETAILS
3 - 6	INSTALLATION DETAILS
7	COMPONENTS

<b>NAN YA PLASTICS CORPORATION USA</b> 8989 NORTH LOOP EAST HOUSTON, TX 77029		
SERIES "PRBJ" FIBERGLASS OUTSWING FOLDING DOOR - IMPACT NOTES		
DRAWN: A.R.	DWG NO. 08-03236	REV A
SCALE NTS	DATE 04/10/18	SHEET 1 OF 7
L. ROBERTO LOMAS P.E. 1432 WOODFORD RD LEWISVILLE, NC 27023 434-688-0609 rllomas@lrlomaspe.com		

SIGNED: 04/01/2021



Luis R. Lomas P.E.  
TX No.: 101889

REVISIONS			
REV	DESCRIPTION	DATE	APPROVED
A	REVISED PER NEW CODE	02/11/2021	R.L.

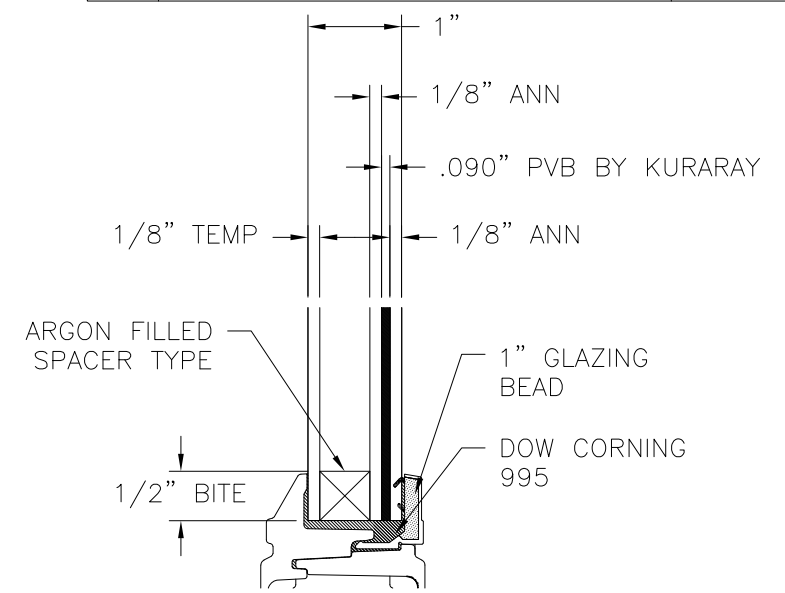
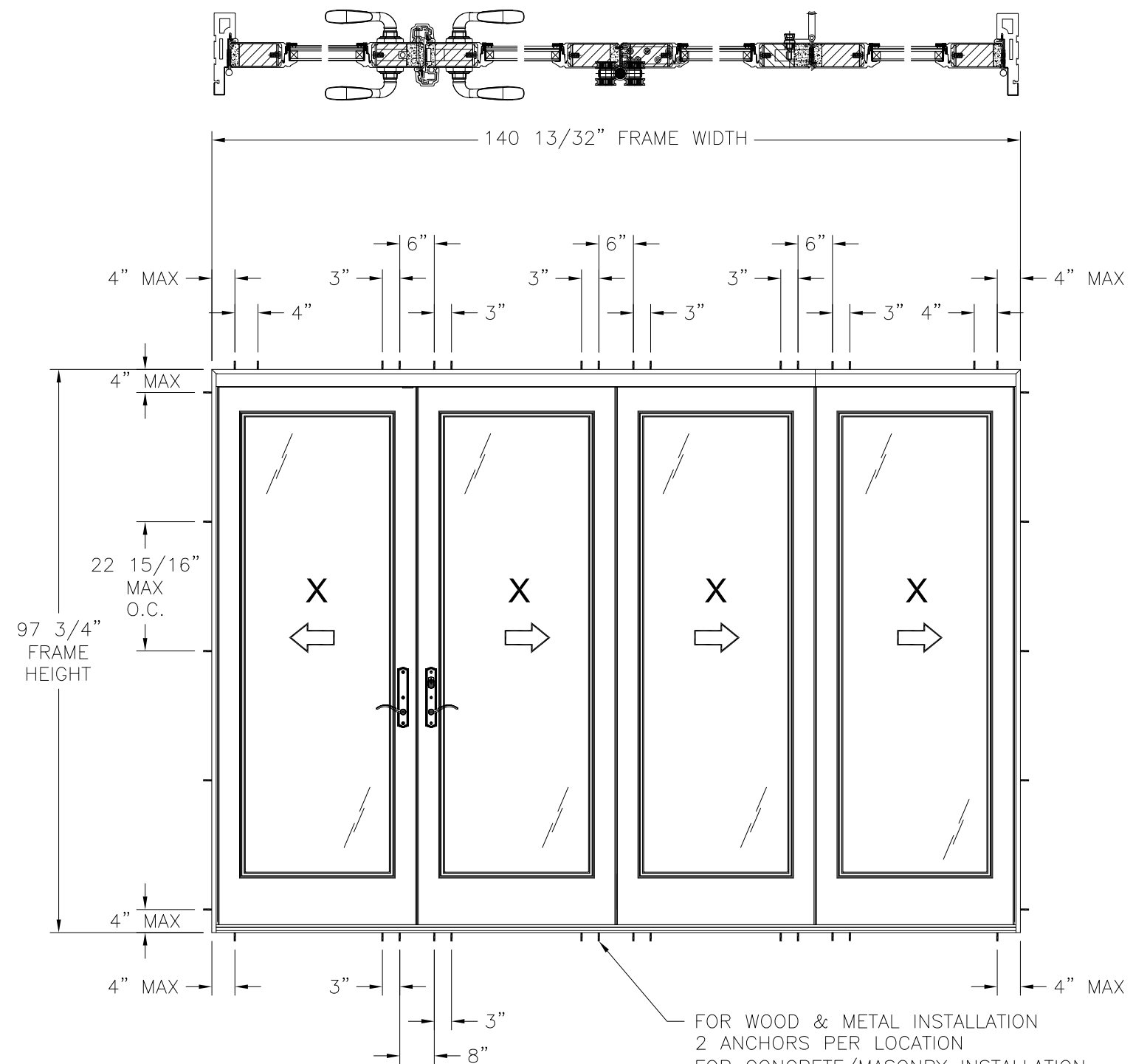

**GLAZING DETAIL**

HARDWARE SCHEDULE	
A.	(1) SLAB MULTI-POINT LOCK KEEPER (STAINLESS STEEL)
B.	(1) HOOK KEEPER (STAINLESS STEEL)
C.	TOP AND BOTTOM BAR KEEPER AT FRAME HEAD AND SILL (STAINLESS STEEL)
D.	(1) DRIVE BAR PLATE (STAINLESS STEEL)
E.	(1) DRIVE BAR PLATE GASKET (TPE)
F.	TOP AND BOTTOM DRIVE BAR SYSTEM (STAINLESS STEEL, STEEL)
G.	(1) FLUSH BOLT SYSTEM (DIE CAST, STEEL)
H.	(1) STEEL 4 X 3 1/4 DOOR HINGE (A)
J.	(1) STEEL 4 X 3 1/4 DOOR HINGE (B)
K.	(1) HANDLE SET AT ACTIVE AND PASSIVE PANEL WITH ASTRAGAL
L.	WOOD REINFORCEMENT 2 5/8" (A) (WHITE PINE)
M.	WOOD REINFORCEMENT 2 1/8" (B) (WHITE PINE)
N.	WOOD REINFORCEMENT 1 3/8" (C) (WHITE PINE)
O.	STEEL REINFORCEMENT 1/8" (SPHC)
P.	SCREW 11/32" X 19/32" (NYLON 66)
Q.	T-ASTRAGAL REINFORCEMENT (ALUMINUM)

- NOTES:**  
 1. PANEL SIZE.: 34 1/2" X 93 5/16"  
 2. D.L.O.: 25" X 79"

SIGNED: 04/01/2021

**SERIES "PRBJ" FIBERGLASS OUTSWING FOLDING DOOR**

DESIGN PRESSURE RATING	IMPACT RATING
±60.0PSF	LARGE AND SMALL MISSILE IMPACT

MISSILE LEVEL D, WIND ZONE 4

FOR WOOD & METAL INSTALLATION  
 2 ANCHORS PER LOCATION  
 FOR CONCRETE/MASONRY INSTALLATION  
 1 ANCHOR PER LOCATION

**NAN YA PLASTICS CORPORATION USA**  
 8989 NORTH LOOP EAST  
 HOUSTON, TX 77029

SERIES "PRBJ" FIBERGLASS  
 OUTSWING FOLDING DOOR – IMPACT  
 ELEVATION AND GLAZING DETAIL

DRAWN: A.R.	DWG NO. 08-03236	REV A
SCALE NTS	DATE 04/10/18	SHEET 2 OF 7

L. ROBERTO LOMAS P.E.  
 1432 WOODFORD RD LEWISVILLE, NC 27023  
 434-688-0609 rllomas@rlomaspe.com



Luis R. Lomas P.E.  
 TX No.: 101889

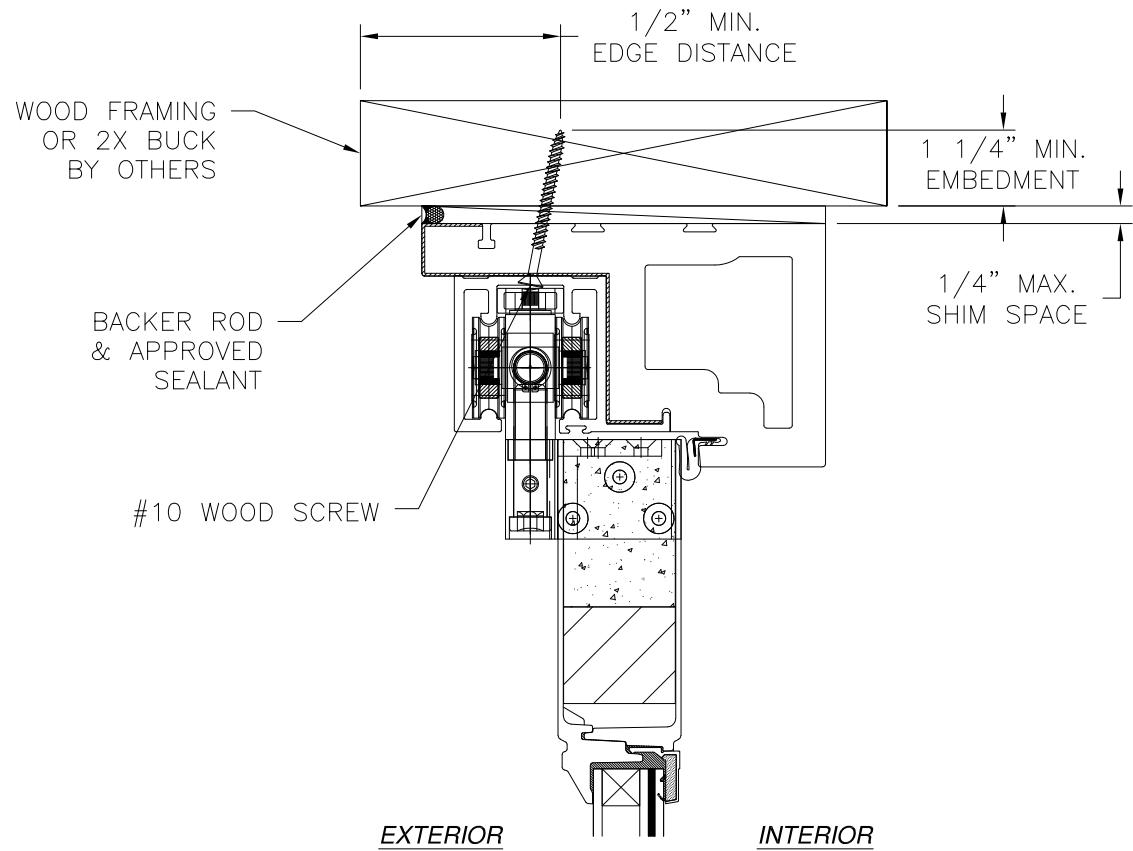

EXTERIOR INTERIOR

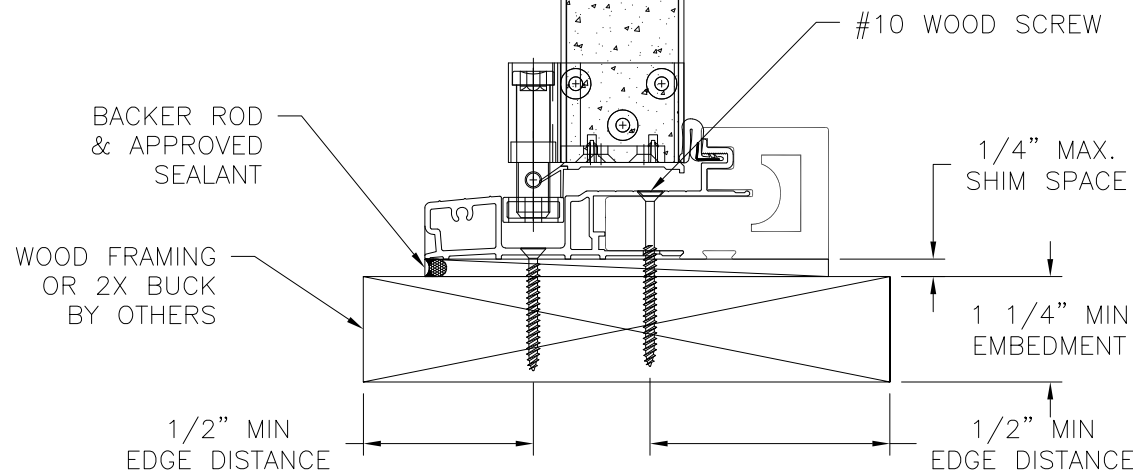

**VERTICAL CROSS SECTION**  
WOOD FRAMING OR 2X BUCK INSTALLATION

REVISIONS			
REV	DESCRIPTION	DATE	APPROVED
A	REVISED PER NEW CODE	02/11/2021	R.L.

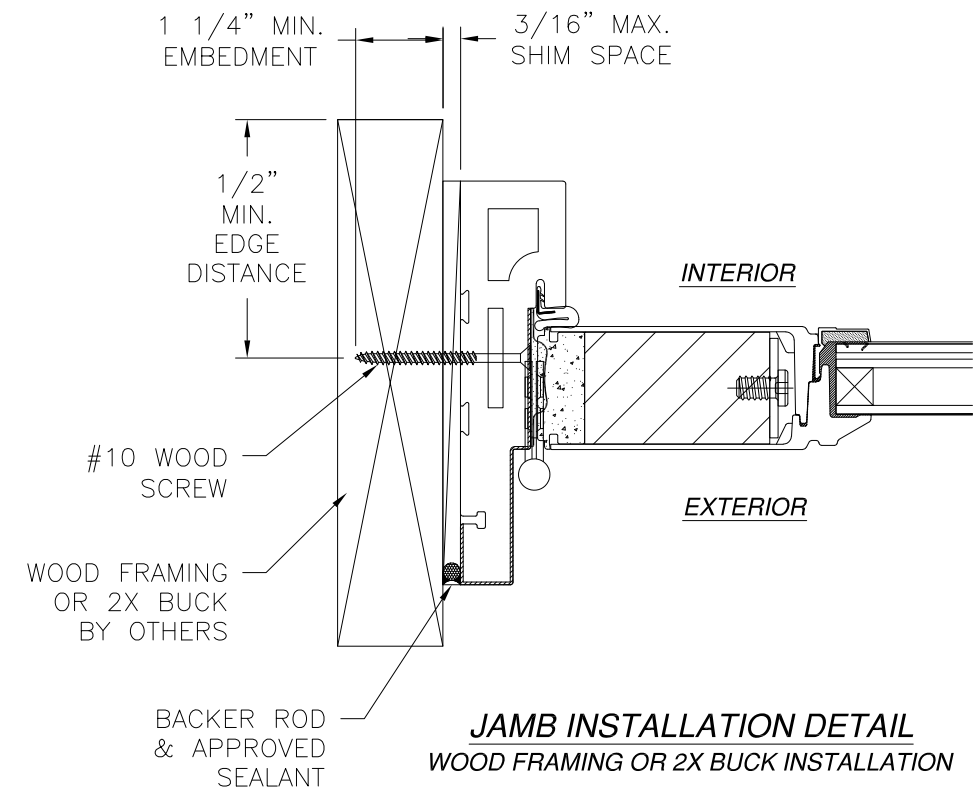

**JAMB INSTALLATION DETAIL**  
WOOD FRAMING OR 2X BUCK INSTALLATION

- NOTES:**
1. INTERIOR AND EXTERIOR FINISHES, BY OTHERS, NOT SHOWN FOR CLARITY.
  2. PERIMETER AND JOINT SEALANT BY OTHERS TO BE DESIGNED IN ACCORDANCE WITH ASTM E2112

SIGNED: 04/01/2021

**NAN YA PLASTICS CORPORATION USA**  
8989 NORTH LOOP EAST  
HOUSTON, TX 77029

SERIES "PRBJ" FIBERGLASS  
OUTSWING FOLDING DOOR - IMPACT  
INSTALLATION DETAILS

DRAWN: A.R.	DWG NO. 08-03236	REV A
SCALE NTS	DATE 04/10/18	SHEET 3 OF 7

L. ROBERTO LOMAS P.E.  
1432 WOODFORD RD LEWISVILLE, NC 27023  
434-688-0609 rllomas@rlomaspe.com



Luis R. Lomas P.E.  
TX No.: 101889

REVISIONS			
REV	DESCRIPTION	DATE	APPROVED
A	REVISED PER NEW CODE	02/11/2021	R.L.

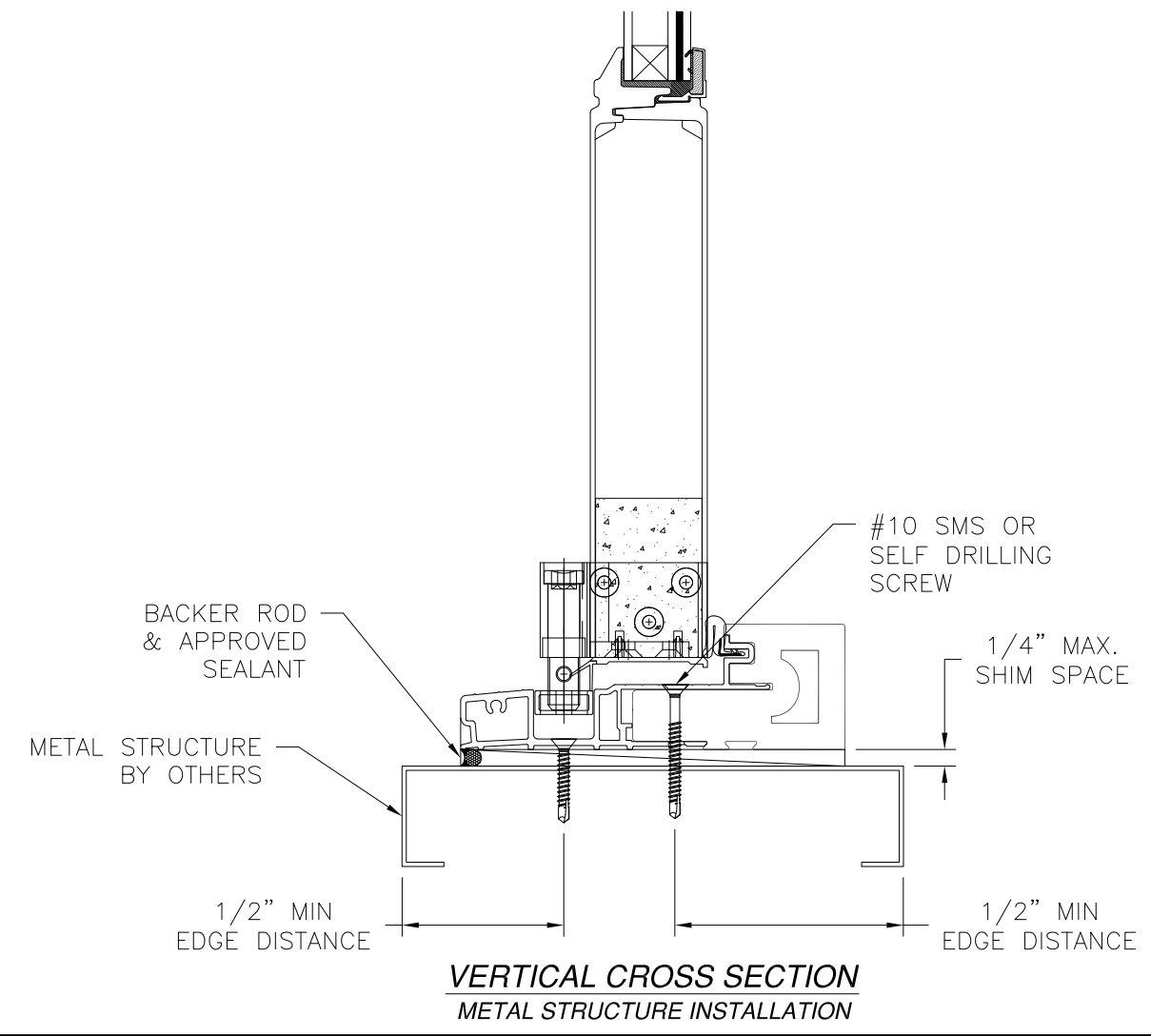
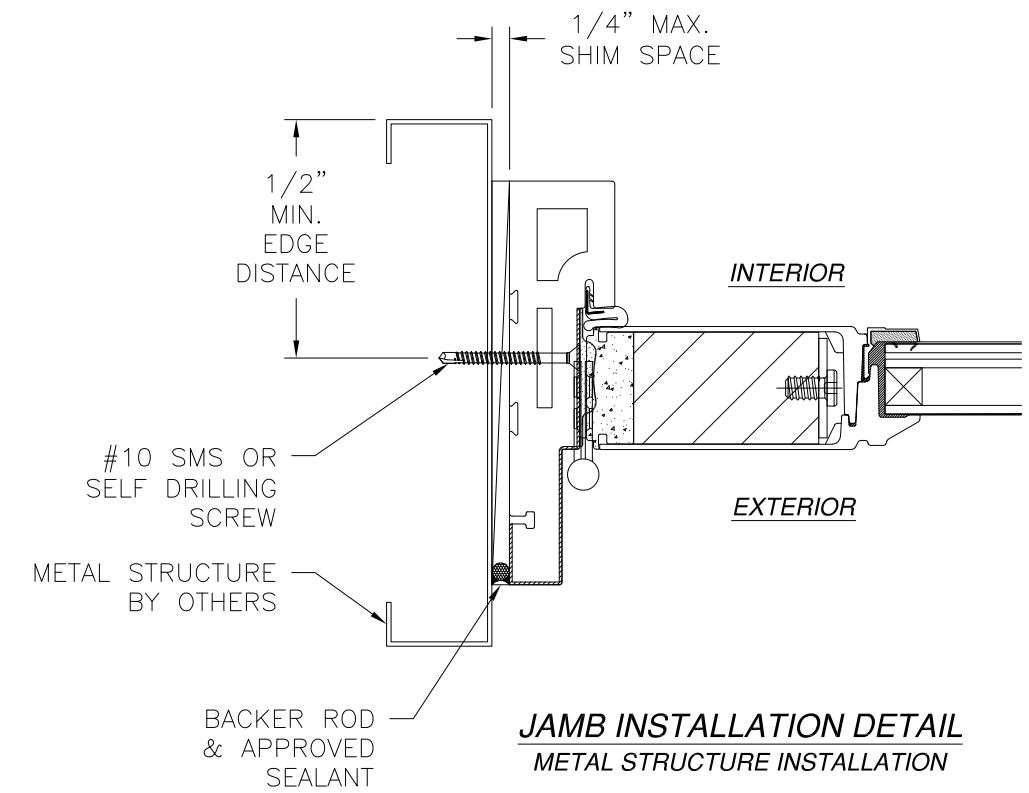
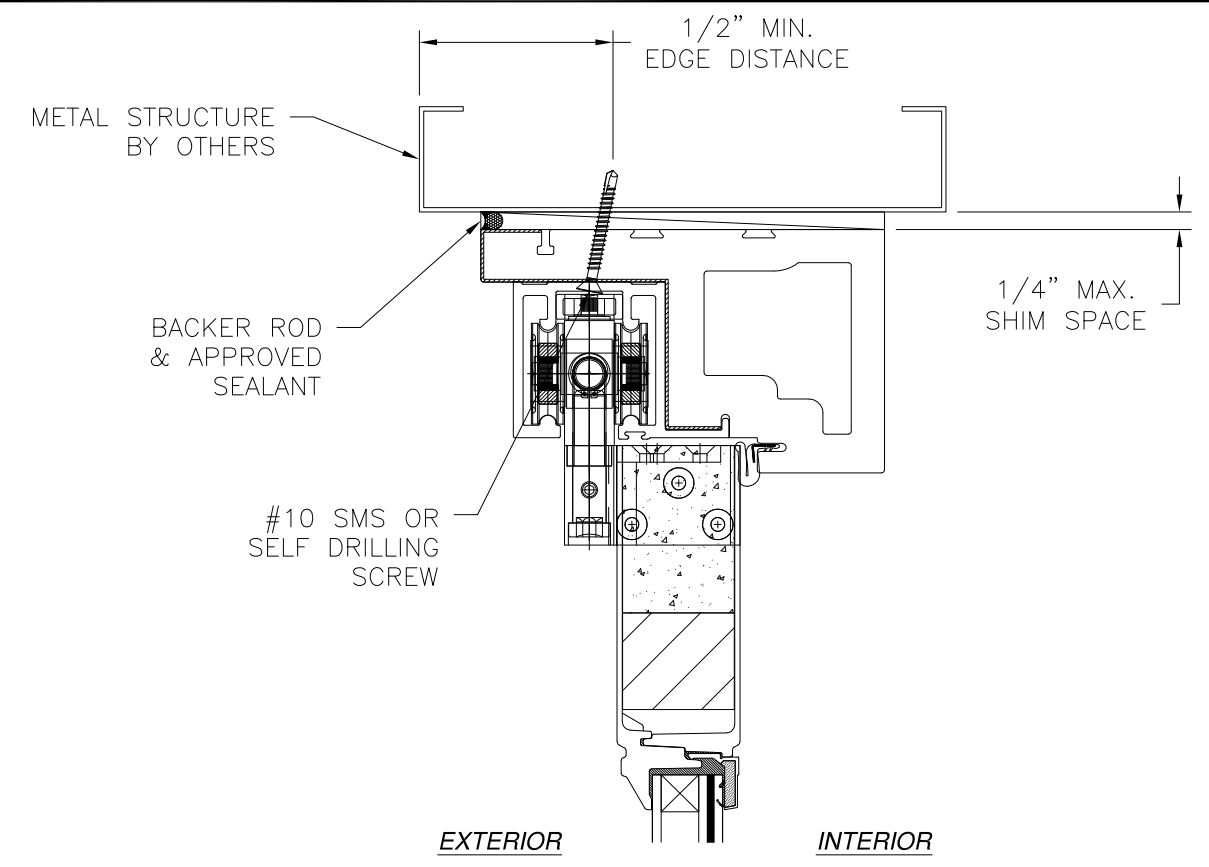

- NOTES:**
1. INTERIOR AND EXTERIOR FINISHES, BY OTHERS, NOT SHOWN FOR CLARITY.
  2. PERIMETER AND JOINT SEALANT BY OTHERS TO BE DESIGNED IN ACCORDANCE WITH ASTM E2112

SIGNED: 04/01/2021

**NAN YA PLASTICS CORPORATION USA**  
 8989 NORTH LOOP EAST  
 HOUSTON, TX 77029

SERIES "PRBJ" FIBERGLASS  
 OUTSWING FOLDING DOOR - IMPACT  
 INSTALLATION DETAILS

DRAWN: A.R.	DWG NO. 08-03236	REV A
SCALE NTS	DATE 04/10/18	SHEET 4 OF 7

L. ROBERTO LOMAS P.E.  
 1432 WOODFORD RD LEWISVILLE, NC 27023  
 434-688-0609 rllomas@rlomaspe.com



Luis R. Lomas P.E.  
 TX No.: 101889

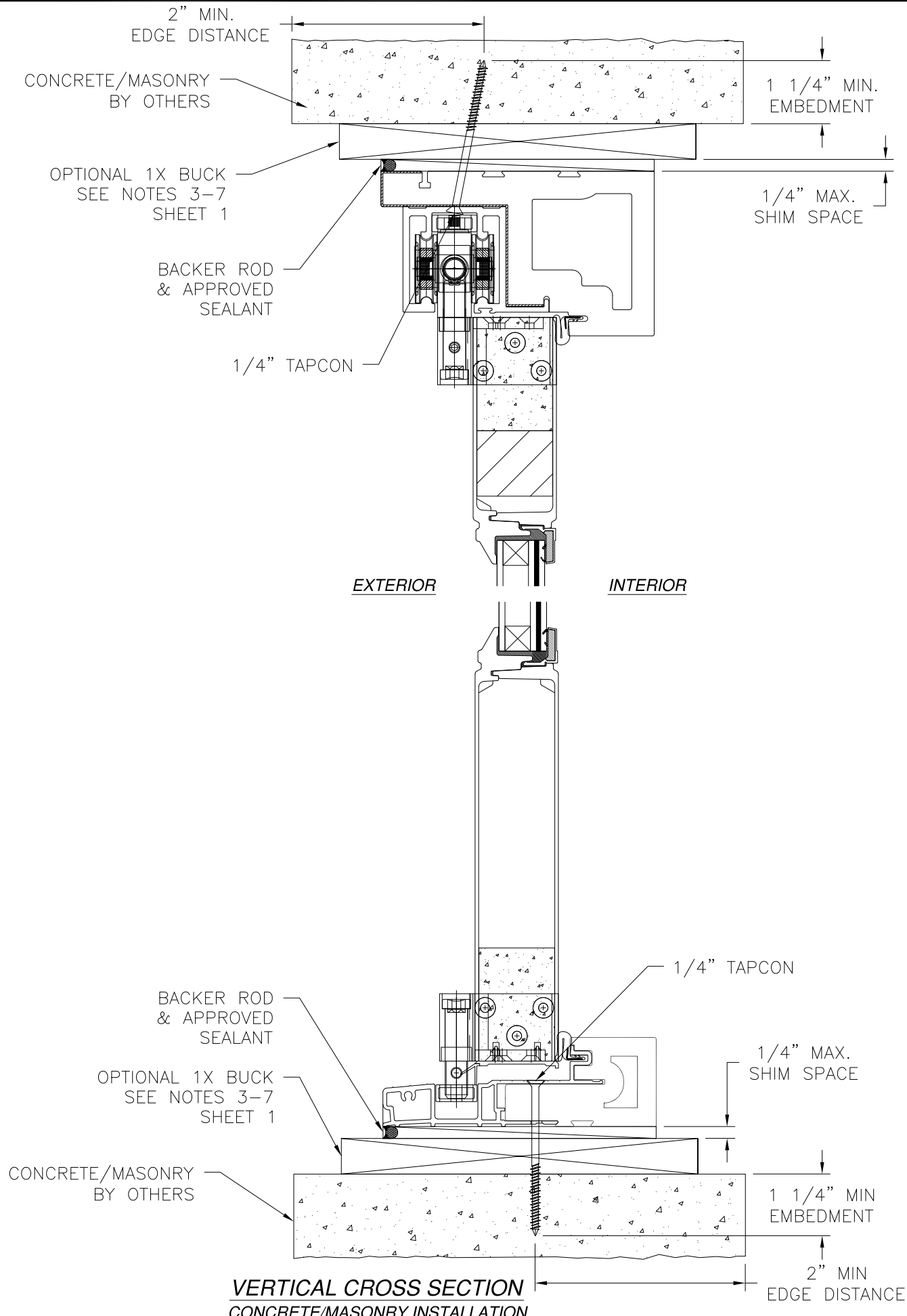

REVISIONS			
REV	DESCRIPTION	DATE	APPROVED
A	REVISED PER NEW CODE	02/11/2021	R.L.

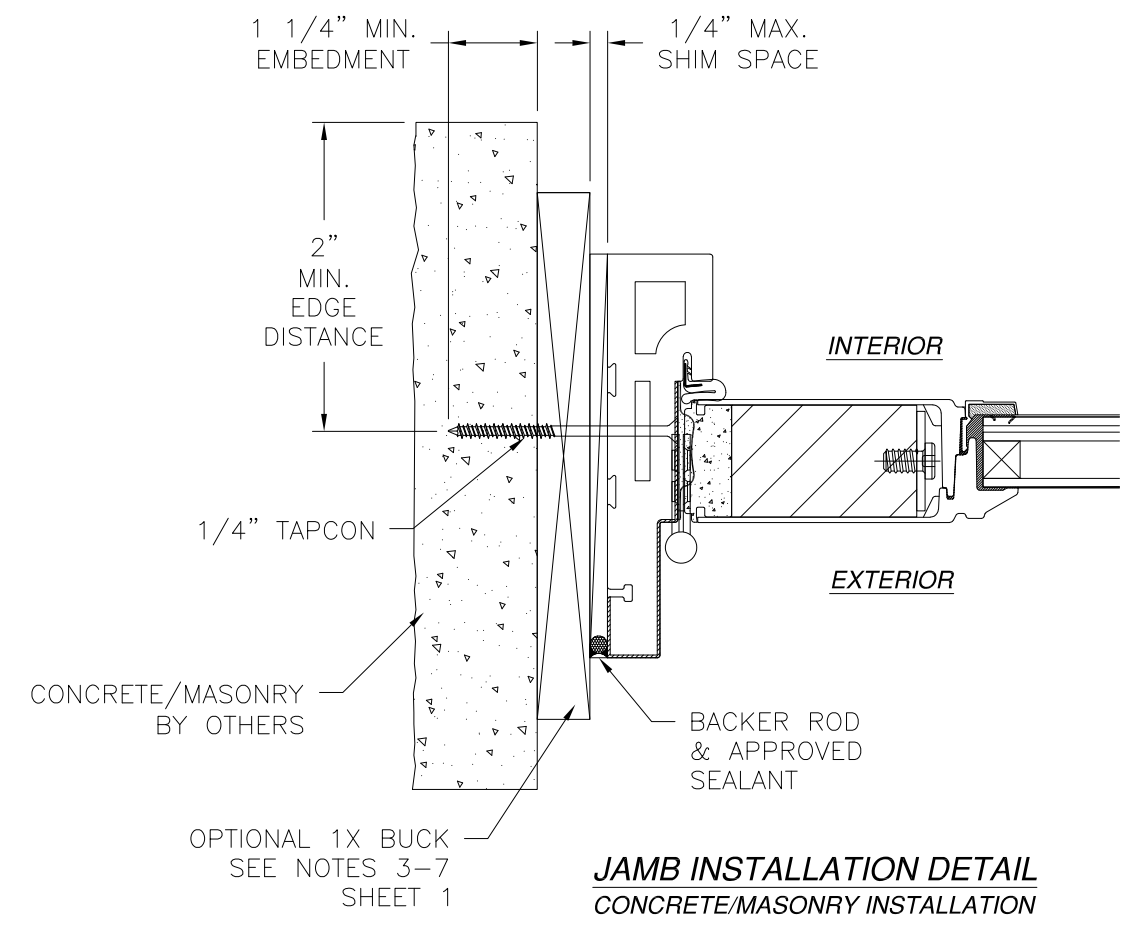

- NOTES:**
1. INTERIOR AND EXTERIOR FINISHES, BY OTHERS, NOT SHOWN FOR CLARITY.
  2. PERIMETER AND JOINT SEALANT BY OTHERS TO BE DESIGNED IN ACCORDANCE WITH ASTM E2112

SIGNED: 04/01/2021

NAN YA PLASTICS CORPORATION USA  
8989 NORTH LOOP EAST  
HOUSTON, TX 77029

SERIES "PRBJ" FIBERGLASS  
OUTSWING FOLDING DOOR - IMPACT  
INSTALLATION DETAILS

DRAWN: A.R.	DWG NO. 08-03236	REV A
SCALE NTS	DATE 04/10/18	SHEET 5 OF 7

L. ROBERTO LOMAS P.E.  
1432 WOODFORD RD LEWISVILLE, NC 27023  
434-688-0609 rllomas@lrlomaspe.com



Luis R. Lomas P.E.  
TX No.: 101889

REVISIONS			
REV	DESCRIPTION	DATE	APPROVED
A	REVISED PER NEW CODE	02/11/2021	R.L.

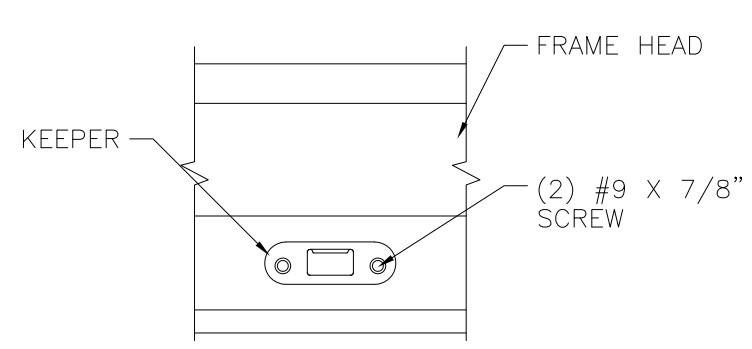

**HEAD BAR KEEPER DETAIL**

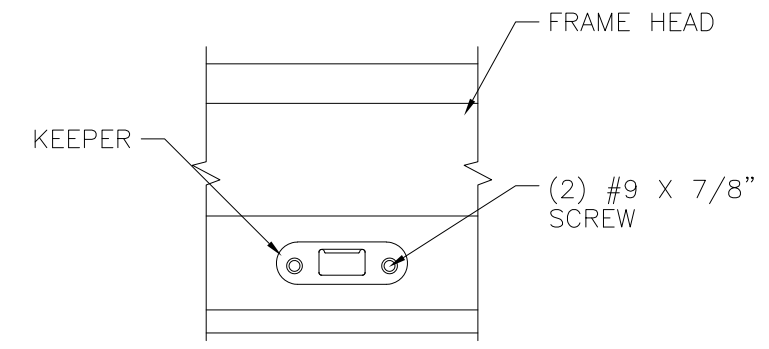

**SILL BAR KEEPER DETAIL**  
FOAM PVC CO-EX

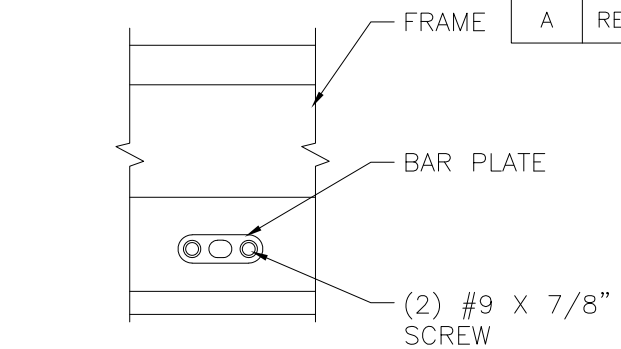

**DRIVE BAR PLATE DETAIL**

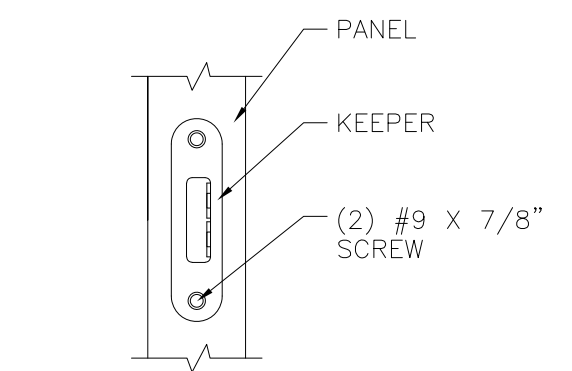

**HOOK KEEPER DETAIL**

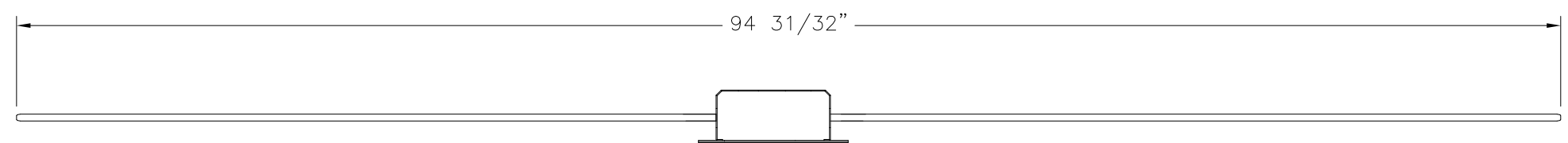

**TOP/BOTTOM DRIVE BAR SYSTEM**  
STAINLESS STEEL BY JAM YUAN ENTERPRISES CO., LTD.

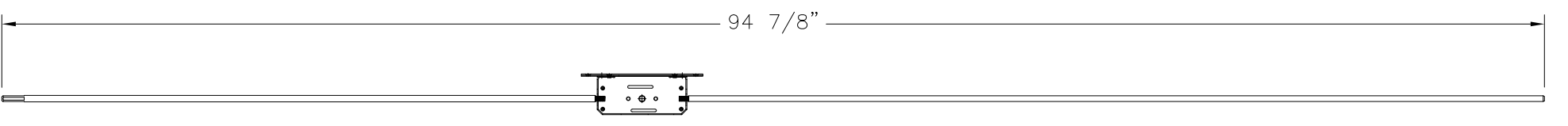

**FLUSH BOLT SYSTEM**  
STEEL BY JAM YUAN ENTERPRISES CO., LTD.

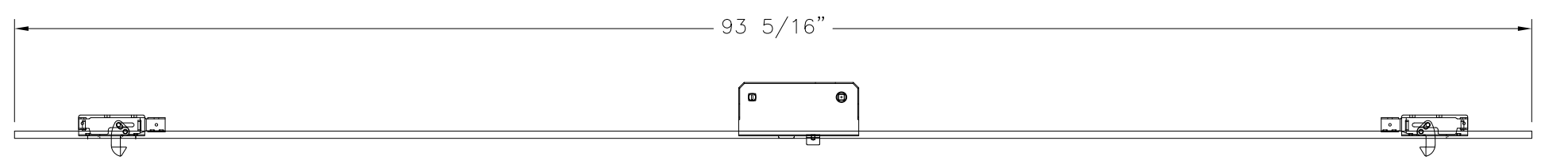

**MULTI-POINT LOCKING SYSTEM**  
STAINLESS STEEL BY JAM YUAN ENTERPRISES CO., LTD.

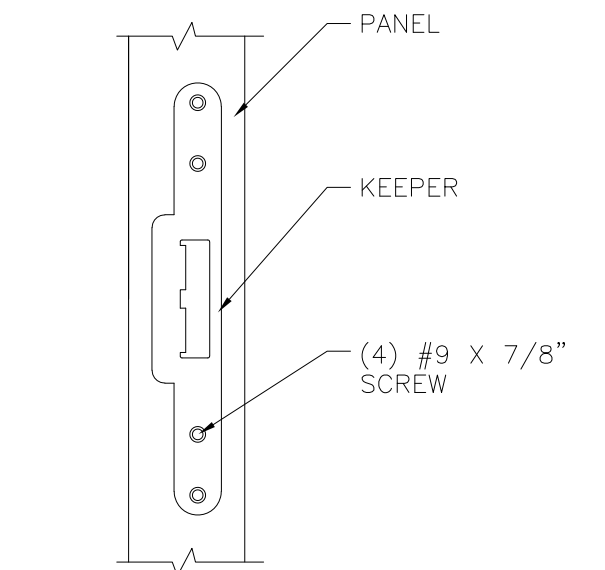

**SLAB MULTI-POINT LOCK KEEPER DETAIL**

SIGNED: 04/01/2021

NAN YA PLASTICS CORPORATION USA  
8989 NORTH LOOP EAST  
HOUSTON, TX 77029

SERIES "PRBJ" FIBERGLASS  
OUTSWING FOLDING DOOR - IMPACT  
COMPONENTS AND INSTALLATION DETAILS

DRAWN: A.R.	DWG NO. 08-03236	REV A
SCALE NTS	DATE 04/10/18	SHEET 6 OF 7

L. ROBERTO LOMAS P.E.  
1432 WOODFORD RD LEWISVILLE, NC 27023  
434-688-0609 rllomas@lrlomaspe.com



Luis R. Lomas P.E.  
TX No.: 101889

REVISIONS			
REV	DESCRIPTION	DATE	APPROVED
A	REVISED PER NEW CODE	02/11/2021	R.L.

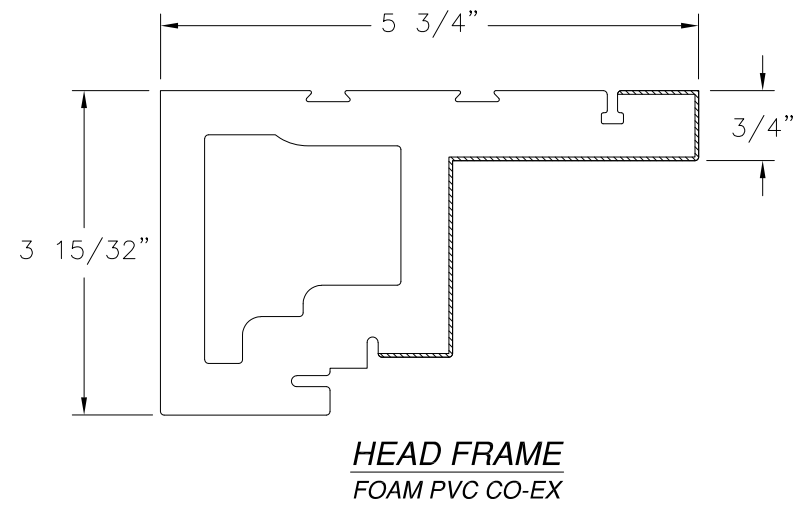

**HEAD FRAME**  
FOAM PVC CO-EX

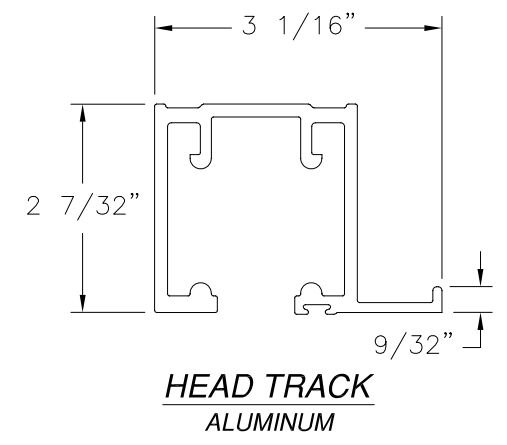

**HEAD TRACK**  
ALUMINUM

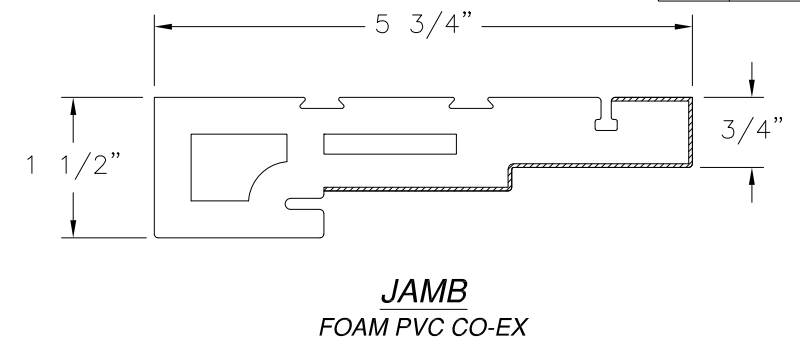

**JAMB**  
FOAM PVC CO-EX

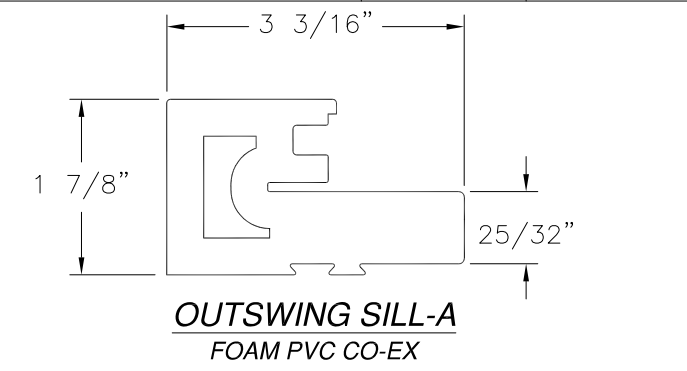

**OUTSWING SILL-A**  
FOAM PVC CO-EX

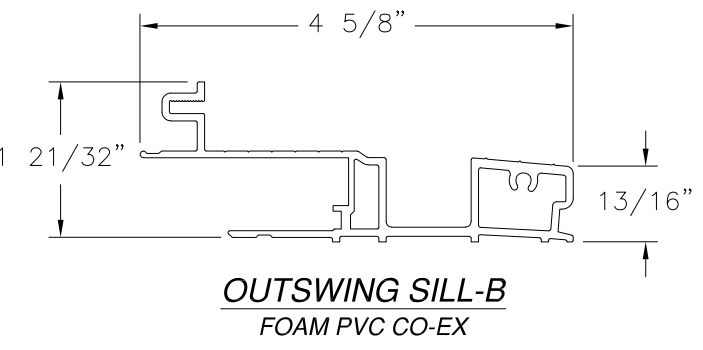

**OUTSWING SILL-B**  
FOAM PVC CO-EX

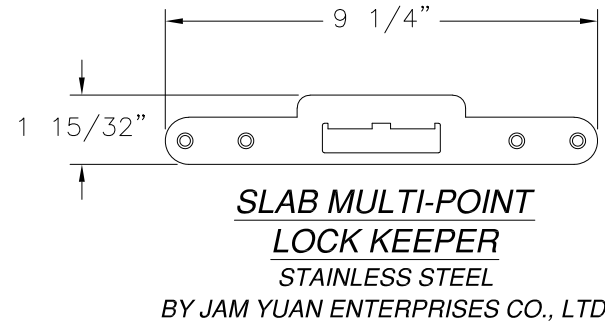

**SLAB MULTI-POINT LOCK KEEPER**  
STAINLESS STEEL  
BY JAM YUAN ENTERPRISES CO., LTD.

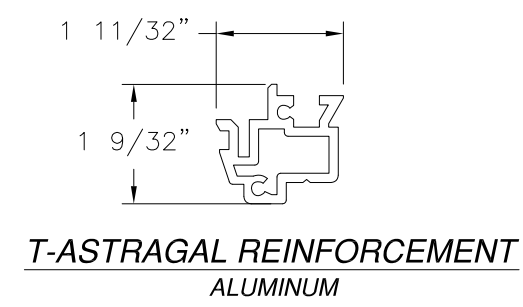

**T-ASTRAGAL REINFORCEMENT**  
ALUMINUM

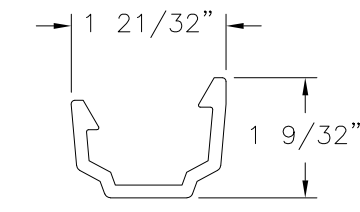

**T-ASTRAGAL RIGID PVC**



**TOP & BOTTOM BAR KEEPER**  
STAINLESS STEEL  
BY JIUH-CHUAN LOCKS CO., LTD

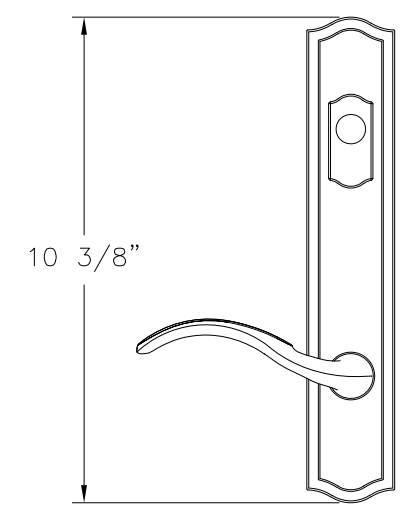

**ACTIVE DOOR HANDLE SET**  
DIE CAST

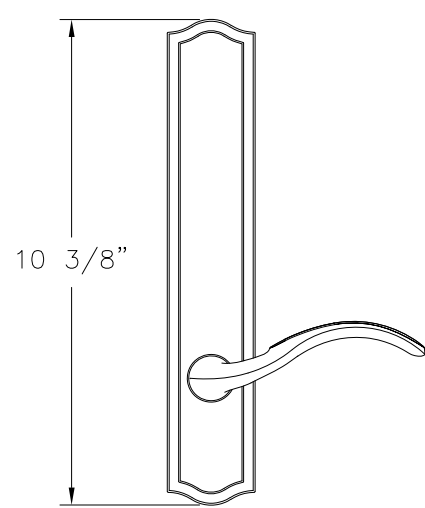

**PASSIVE DOOR HANDLE SET**  
DIE CAST

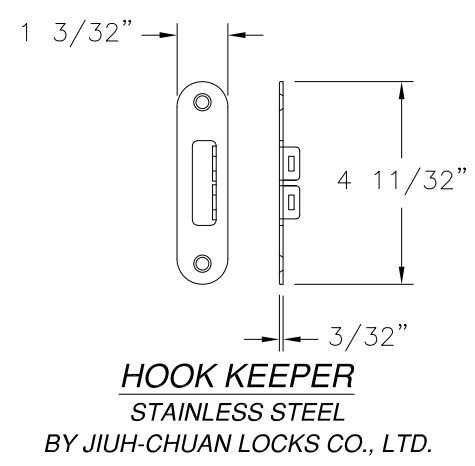

**HOOK KEEPER**  
STAINLESS STEEL  
BY JIUH-CHUAN LOCKS CO., LTD.

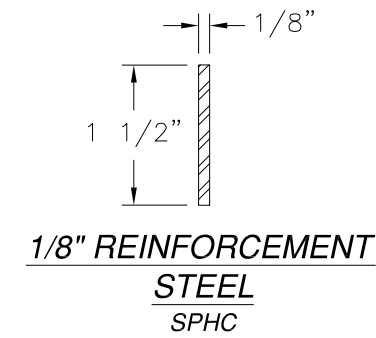

**1/8\"/>**

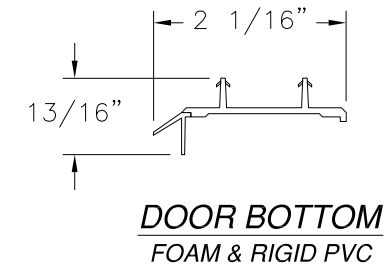

**DOOR BOTTOM**  
FOAM & RIGID PVC

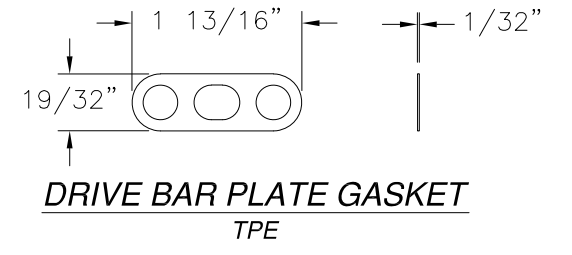

**DRIVE BAR PLATE GASKET**  
TPE

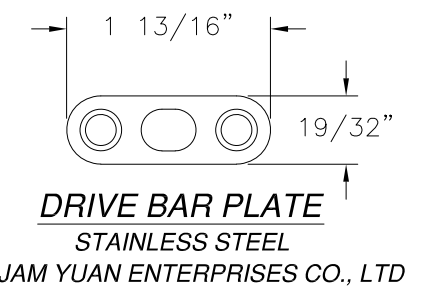

**DRIVE BAR PLATE**  
STAINLESS STEEL  
BY JAM YUAN ENTERPRISES CO., LTD

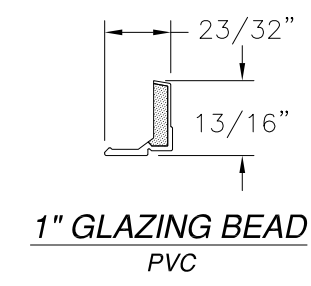

**1\"/>**

SIGNED: 04/01/2021

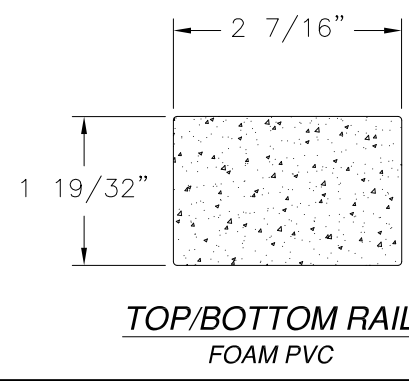

**TOP/BOTTOM RAIL**  
FOAM PVC

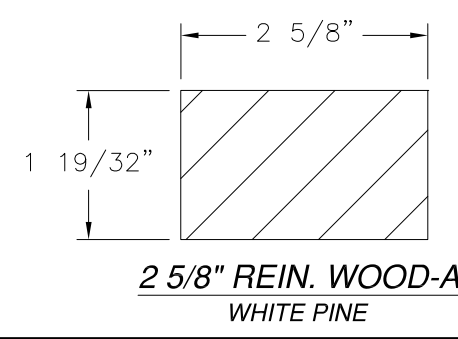

**2 5/8\"/>**

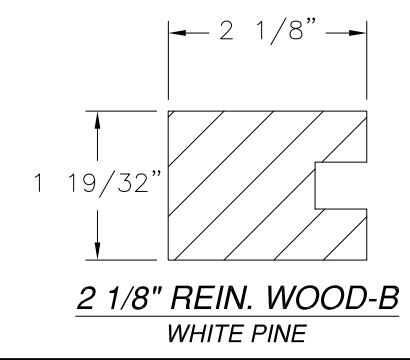

**2 1/8\"/>**

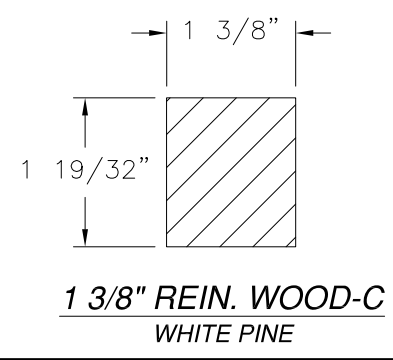

**1 3/8\"/>**

NAN YA PLASTICS CORPORATION USA  
8989 NORTH LOOP EAST  
HOUSTON, TX 77029

SERIES "PRBJ" FIBERGLASS  
OUTSWING FOLDING DOOR - IMPACT  
COMPONENTS

DRAWN: A.R.	DWG NO. 08-03236	REV A
SCALE NTS	DATE 04/10/18	SHEET 7 OF 7

L. ROBERTO LOMAS P.E.  
1432 WOODFORD RD LEWISVILLE, NC 27023  
434-688-0609 rllomas@rlomaspe.com



Luis R. Lomas P.E.  
TX No.: 101889