

REVISIONS			
REV	DESCRIPTION	DATE	APPROVED
A	REVISED TO ADD 3/4 LITE PANEL	02/11/2021	R.L.
B	REVISED TO ADD INSTALLATION DETAILS	03/15/2022	R.L.

NOTES:

1. THE PRODUCT SHOWN HEREIN IS DESIGNED AND MANUFACTURED TO COMPLY WITH REQUIREMENTS OF THE 2018 IBC AND 2018 IRC.
2. WOOD FRAMING AND MASONRY OPENING TO BE DESIGNED AND ANCHORED TO PROPERLY TRANSFER ALL LOADS TO STRUCTURE. FRAMING AND MASONRY OPENING IS THE RESPONSIBILITY OF THE ARCHITECT OR ENGINEER OF RECORD.
3. WHERE SHIM OR BUCK THICKNESS IS LESS THAN 1-1/2" WINDOW UNITS MUST BE ANCHORED THROUGH THE FRAME IN ACCORDANCE WITH MANUFACTURER'S PUBLISHED INSTALLATION INSTRUCTIONS. ANCHORS SHALL BE SECURELY FASTENED DIRECTLY INTO MASONRY, CONCRETE OR OTHER STRUCTURAL SUBSTRATE MATERIAL.
4. WHERE WOOD BUCK THICKNESS IS 1-1/2" OR GREATER, BUCK SHALL BE SECURELY FASTENED TO MASONRY, CONCRETE OR OTHER STRUCTURAL SUBSTRATE. WINDOW UNITS MAY BE ANCHORED THROUGH FRAME TO SECURED WOOD BUCK IN ACCORDANCE WITH MANUFACTURER'S PUBLISHED INSTALLATION INSTRUCTIONS.
5. WHERE 1X BUCK IS NOT USED DISSIMILAR MATERIALS MUST BE SEPARATED WITH APPROVED COATING OR MEMBRANE. SELECTION OF COATING OR MEMBRANE IS THE RESPONSIBILITY OF THE ARCHITECT OR ENGINEER OF RECORD.
6. BUCKS SHALL EXTEND BEYOND WINDOW INTERIOR FACE SO THAT FULL FRAME SUPPORT IS PROVIDED.
7. SHIM AS REQUIRED AT EACH ANCHOR LOCATION WITH LOAD BEARING SHIM. SHIM WHERE SPACE OF 1/16" OR GREATER OCCURS. MAXIMUM ALLOWABLE SHIM STACK TO BE 1/4".
8. SHIMS SHALL BE LOCATED, APPLIED AND MADE FROM MATERIALS AND THICKNESS CAPABLE OF SUSTAINING APPLICABLE LOADS.
9. WIND LOAD DURATION FACTOR Cd=1.6 WAS USED FOR WOOD ANCHOR CALCULATIONS.
10. FRAME MATERIAL: CO-EXTRUDED PVC FOAM.
11. UNITS MUST BE GLAZED PER ASTM E1300, SEE SHEET 17 FOR GLAZING DETAILS.
12. APPROVED IMPACT PROTECTIVE SYSTEM IS NOT REQUIRED FOR THIS PRODUCT IN WIND BORNE DEBRIS REGIONS.
13. FOR ANCHORING INTO WOOD FRAMING OR 2X BUCK USE #10 WOOD SCREWS WITH SUFFICIENT LENGTH TO ACHIEVE A 1 1/4" MINIMUM EMBEDMENT INTO SUBSTRATE. LOCATE ANCHORS AS SHOWN IN ELEVATIONS AND INSTALLATION DETAILS.

14. FOR ANCHORING INTO MASONRY/CONCRETE USE 3/16" TAPCONS WITH SUFFICIENT LENGTH TO ACHIEVE A 1 1/4" MINIMUM EMBEDMENT INTO SUBSTRATE WITH 2" MINIMUM EDGE DISTANCE. LOCATE ANCHORS AS SHOWN IN ELEVATIONS AND INSTALLATION DETAILS.
15. FOR ANCHORING INTO METAL STRUCTURE USE #10 SMS OR SELF DRILLING SCREWS WITH SUFFICIENT LENGTH TO ACHIEVE 3 THREADS MINIMUM BEYOND STRUCTURE INTERIOR WALL. LOCATE ANCHORS AS SHOWN IN ELEVATIONS AND INSTALLATION DETAILS.
16. ALL FASTENERS TO BE CORROSION RESISTANT.
17. INSTALLATION ANCHORS SHALL BE INSTALLED IN ACCORDANCE WITH ANCHOR MANUFACTURER'S INSTALLATION INSTRUCTIONS AND ANCHORS SHALL NOT BE USED IN SUBSTRATES WITH STRENGTHS LESS THAN THE MINIMUM STRENGTH SPECIFIED BELOW:
  - A. WOOD - MINIMUM SPECIFIC GRAVITY OF G=0.42
  - B. CONCRETE - MINIMUM COMPRESSIVE STRENGTH OF 3,192 PSI.
  - C. MASONRY - STRENGTH CONFORMANCE TO ASTM C-90, GRADE N, TYPE 1 (OR GREATER).
  - D. METAL STRUCTURE: STEEL 18GA, 33KSI OR ALUMINUM 6063-T5 .125" THICK MINIMUM
18. APPROVED CONFIGURATIONS: X, X/O, O/X, OX, XO, OX/O, XO/O, XX, XX/O, O/XX, OXX, XXO, OXX/O AND O/XXO, SEE SHEET 3.
19. SIDELITES ARE ASSEMBLED TO FRAME WITH #10 X 3" WOOD SCREWS LOCATED 4" FROM EACH END AND 19 1/8" MAX O.C. THEREAFTER AT JAMBS AND 4" FROM EACH END AND ONE AT MIDSPAN AT HEAD AND SILL.

TABLE OF CONTENTS	
SHEET NO.	DESCRIPTION
1	NOTES
2	ELEVATIONS
3 - 4	APPROVED CONFIGURATIONS
5 - 6	ANCHORING LAYOUTS
7 - 15	INSTALLATION DETAILS
16 - 17	COMPONENTS & GLAZING DETAIL

**NAN YA PLASTICS CORPORATION U.S.A.**  
8989 NORTH LOOP EAST  
HOUSTON, TX 77029

---

SERIES "SLPS" GLAZED FIBERGLASS INSWING  
SIDE-HINGED DOOR W/SIDELITES - IMPACT  
NOTES

DRAWN: A.R.	DWG NO. 08-03313	REV B
SCALE NTS	DATE 09/27/18	SHEET 1 OF 17

**L. ROBERTO LOMAS P.E.**  
400 S. PALM AVE, INDIALANTIC, FL 32903  
434-688-0609 rllomas@rlomaspe.com

SIGNED: 03/25/2022



Luis R. Lomas P.E.  
TX No.: 101889  
Firm No: F-23130

REVISIONS			
REV	DESCRIPTION	DATE	APPROVED
A	REVISED TO ADD 3/4 LITE PANEL	02/11/2021	R.L.
B	REVISED TO ADD INSTALLATION DETAILS	03/15/2022	R.L.

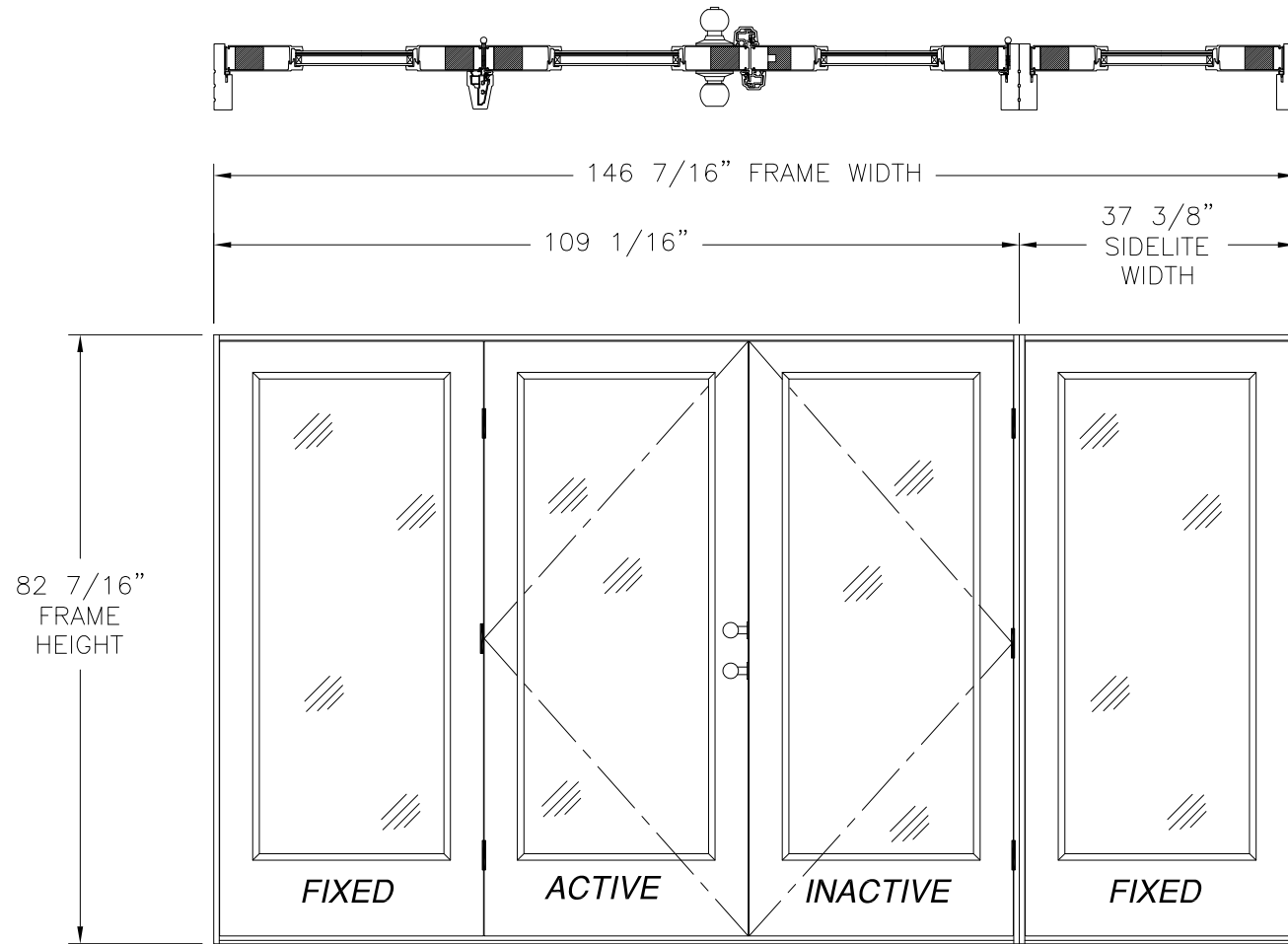

**SERIES SLPS IN-SWING SIDE-HINGED DOOR W/SIDELITES**  
EXTERIOR VIEW  
FULL LITE PANEL

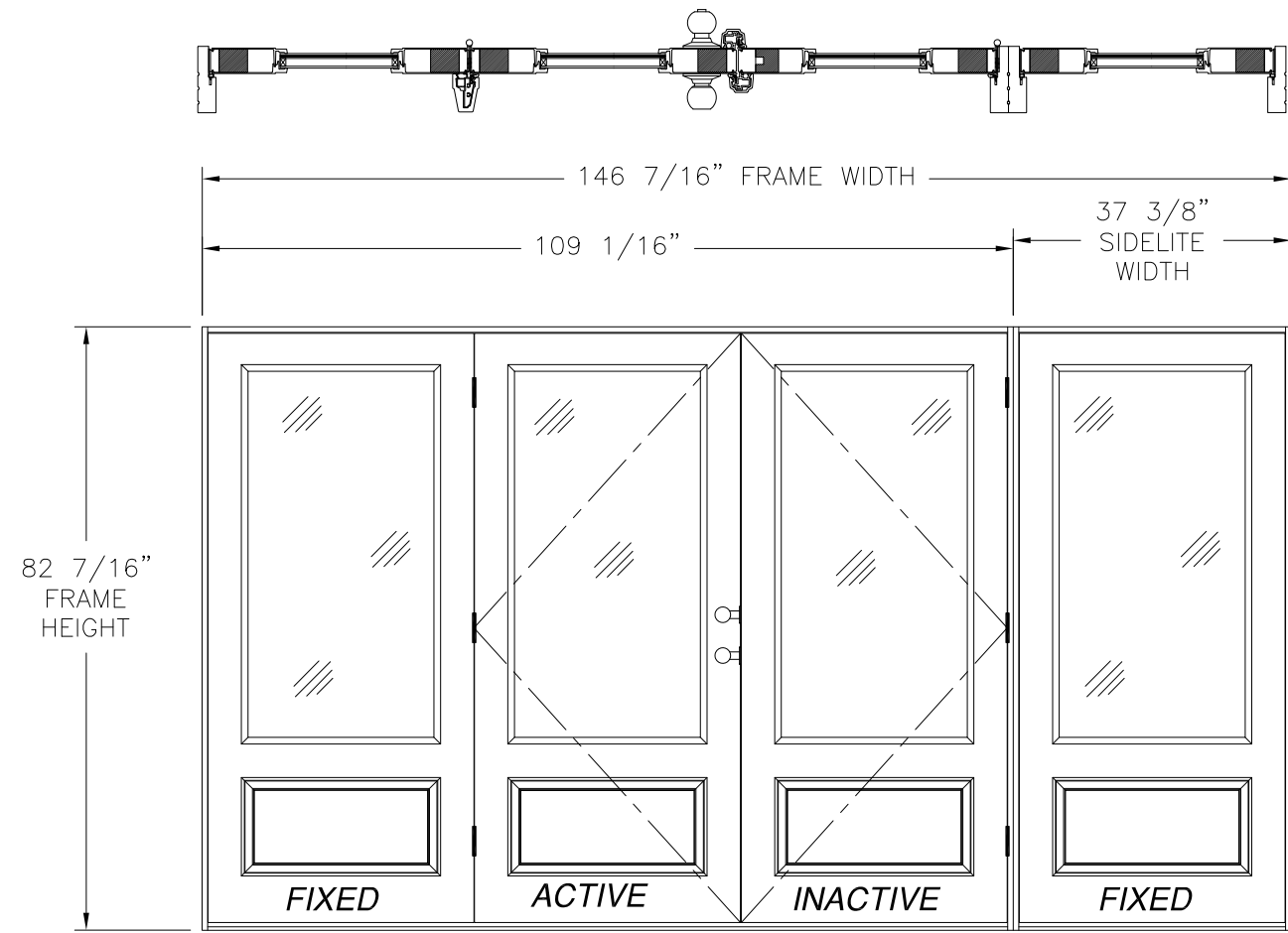

**SERIES SLPS IN-SWING SIDE-HINGED DOOR W/SIDELITES**  
EXTERIOR VIEW  
3/4" LITE PANEL

DESIGN PRESSURE RATING	IMPACT RATING
±40.0PSF	LARGE AND SMALL MISSILE IMPACT

MISSILE LEVEL D, WIND ZONE 4

**NOTES:**

- PANEL SIZE: 35 3/4" X 79 1/4"
- D.L.O.: 25" X 63"

**HARDWARE SCHEDULE**

A.	HANDLE SETS AT ACTIVE PANEL
B.	STAINLESS STEEL FLUSH BOLT BAR WITH STRIKE PLATES AT PASSIVE PANEL
C.	FLUSH BOLT MECHANISM (DIE CAST, STEEL, POM) AT PASSIVE PANEL
D.	STEEL DEADBOLT WITH KEEPER AT ACTIVE PANEL, AT 38 3/4" FROM FRAME HEAD
E.	STEEL LATCH WITH KEEPER AT ACTIVE PANEL, AT 44 1/4" FROM FRAME HEAD
F.	(3) 4X4 DOOR HINGE AT STILE OF ACTIVE AND PASSIVE PANEL, AT 8 5/8", 40 3/8" AND 72 3/16" FROM FRAME HEAD
G.	T-ASTRAGAL AT ACTIVE AND PASSIVE PANELS
H.	ALUMINUM REINFORCEMENT (A) AT ASTRAGAL
I.	ALUMINUM MULLION REINFORCEMENT (B) AT INTEGRAL MULLION

SIGNED: 03/25/2022

NAN YA PLASTICS CORPORATION U.S.A.  
8989 NORTH LOOP EAST  
HOUSTON, TX 77029

SERIES "SLPS" GLAZED FIBERGLASS INSWING  
SIDE-HINGED DOOR W/SIDELITES - IMPACT  
ELEVATIONS

DRAWN: A.R.	DWG NO. 08-03313	REV B
SCALE NTS	DATE 09/27/18	SHEET 2 OF 17
L. ROBERTO LOMAS P.E. 400 S. PALM AVE, INDIALANTIC, FL 32903 434-688-0609 rllomas@rlomaspe.com		



Luis R. Lomas P.E.  
TX No.: 101889  
Firm No: F-23130

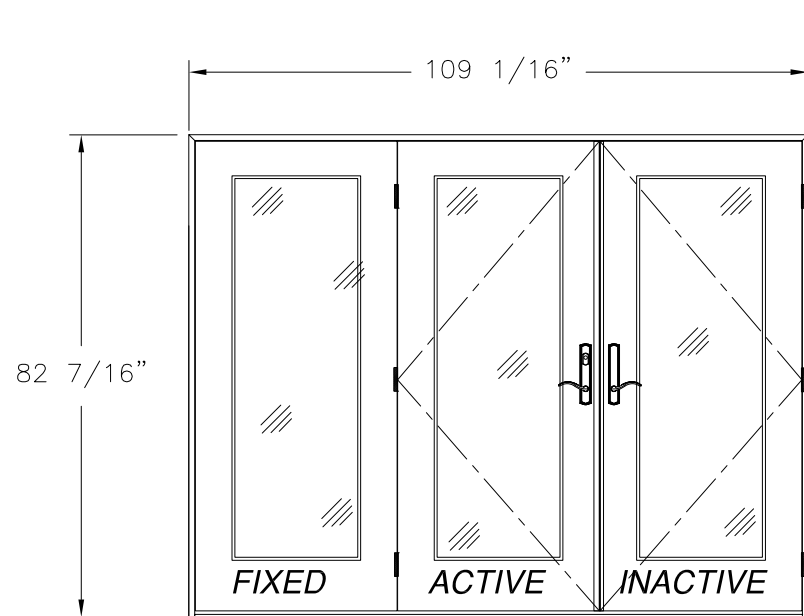

**DOUBLE W/SIDELITE**  
EXTERIOR VIEW

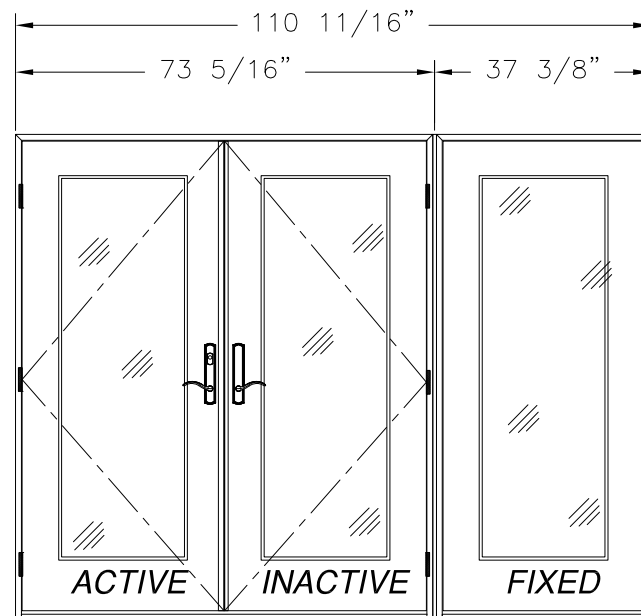

**DOUBLE W/SIDELITE (MULL)**  
EXTERIOR VIEW

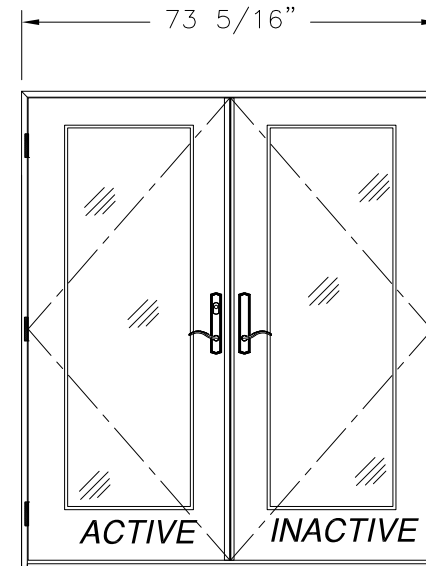

**DOUBLE**  
EXTERIOR VIEW

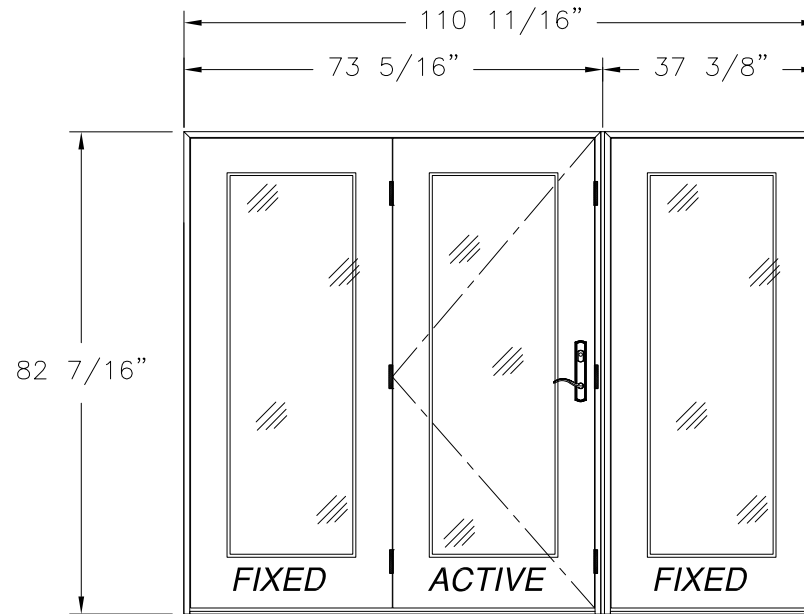

**SINGLE W/SIDELITE (MULL)**  
EXTERIOR VIEW

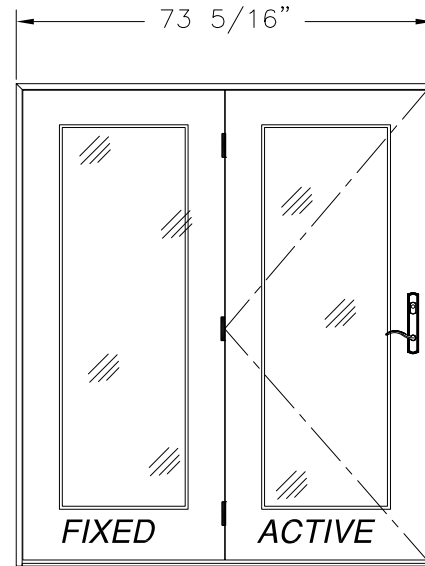

**SINGLE W/SIDELITE**  
EXTERIOR VIEW

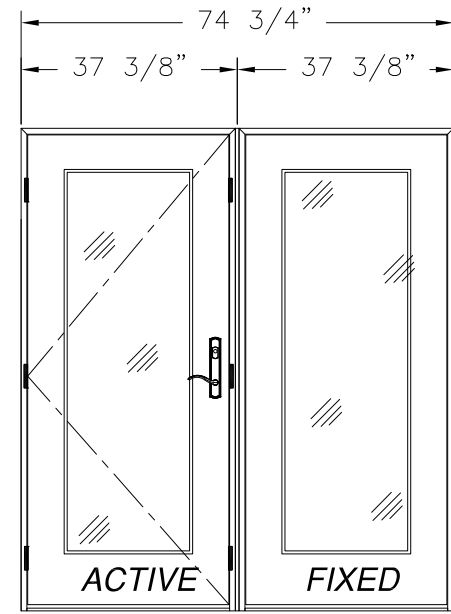

**SINGLE W/SIDELITE (MULL)**  
EXTERIOR VIEW

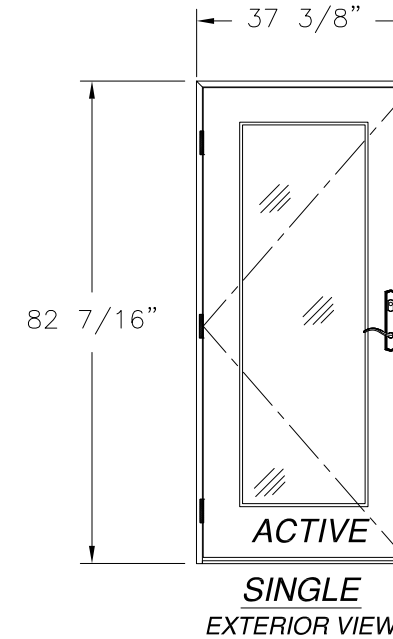

**SINGLE**  
EXTERIOR VIEW

REVISIONS			
REV	DESCRIPTION	DATE	APPROVED
A	REVISED TO ADD 3/4 LITE PANEL	02/11/2021	R.L.
B	REVISED TO ADD INSTALLATION DETAILS	03/15/2022	R.L.

NOTE:  
ALL APPROVED CONFIGURATIONS ARE SHOWN AS LEFT  
HAND ACTIVE, RIGHT HAND ACTIVE IS ALSO APPROVED.

SIGNED: 03/25/2022

NAN YA PLASTICS CORPORATION U.S.A.  
8989 NORTH LOOP EAST  
HOUSTON, TX 77029

SERIES "SLPS" GLAZED FIBERGLASS INSWING  
SIDE-HINGED DOOR W/SIDELITES - IMPACT  
APPROVED CONFIGURATIONS FULL LITE PANEL

DRAWN: A.R.	DWG NO. 08-03313	REV B
----------------	---------------------	----------

SCALE NTS	DATE 09/27/18	SHEET 3 OF 17
-----------	---------------	---------------

L. ROBERTO LOMAS P.E.  
400 S. PALM AVE, INDIALANTIC, FL 32903  
434-688-0609 rllomas@rlomaspe.com



Luis R. Lomas P.E.  
TX No.: 101889  
Firm No: F-23130

REVISIONS			
REV	DESCRIPTION	DATE	APPROVED
A	REVISED TO ADD 3/4 LITE PANEL	02/11/2021	R.L.
B	REVISED TO ADD INSTALLATION DETAILS	03/15/2022	R.L.

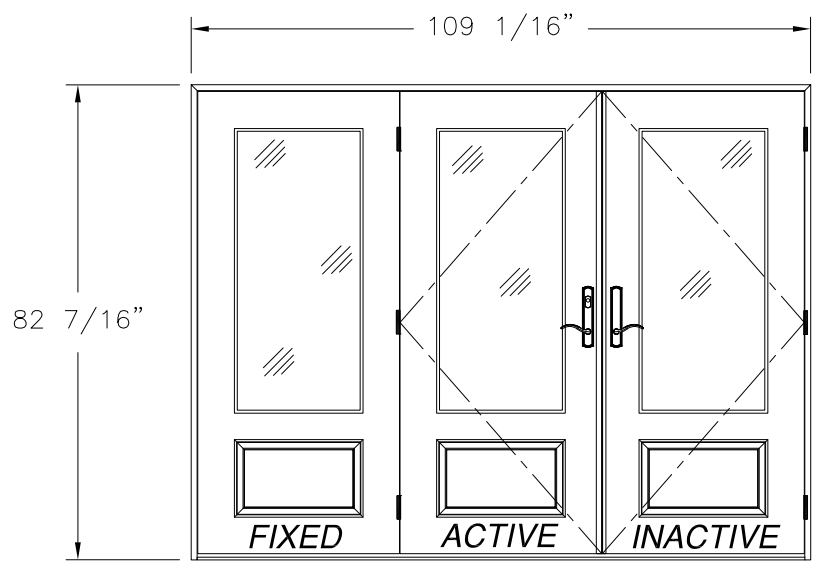

**DOUBLE W/SIDELITE**  
EXTERIOR VIEW

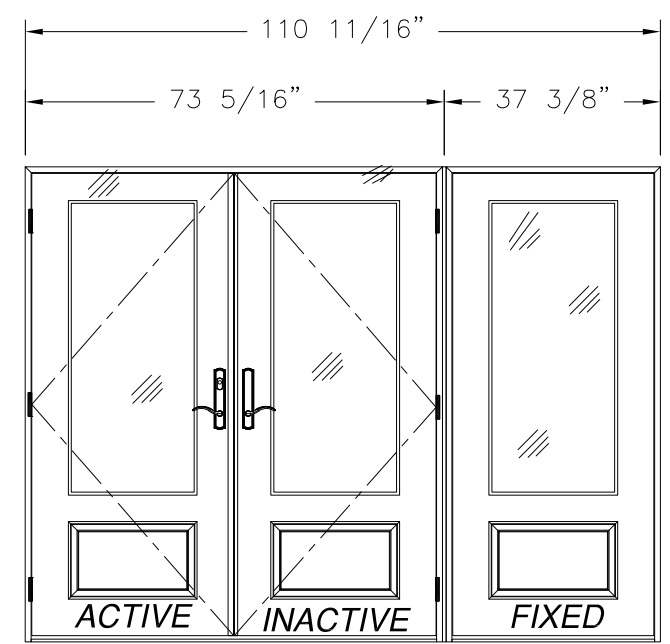

**DOUBLE W/SIDELITE (MULL)**  
EXTERIOR VIEW

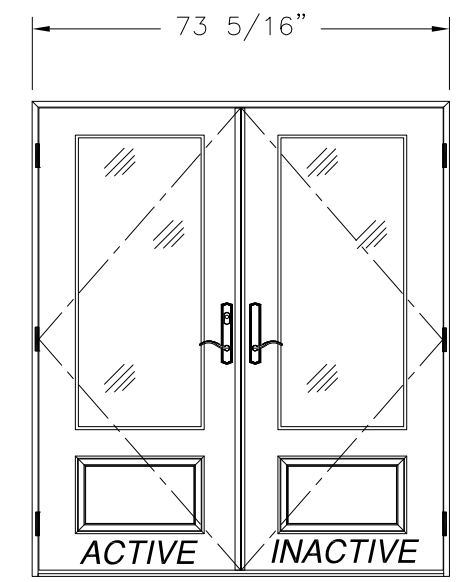

**DOUBLE**  
EXTERIOR VIEW

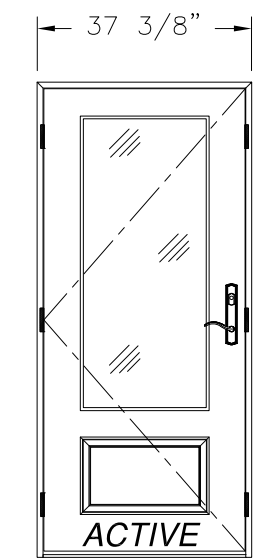

**SINGLE**  
EXTERIOR VIEW

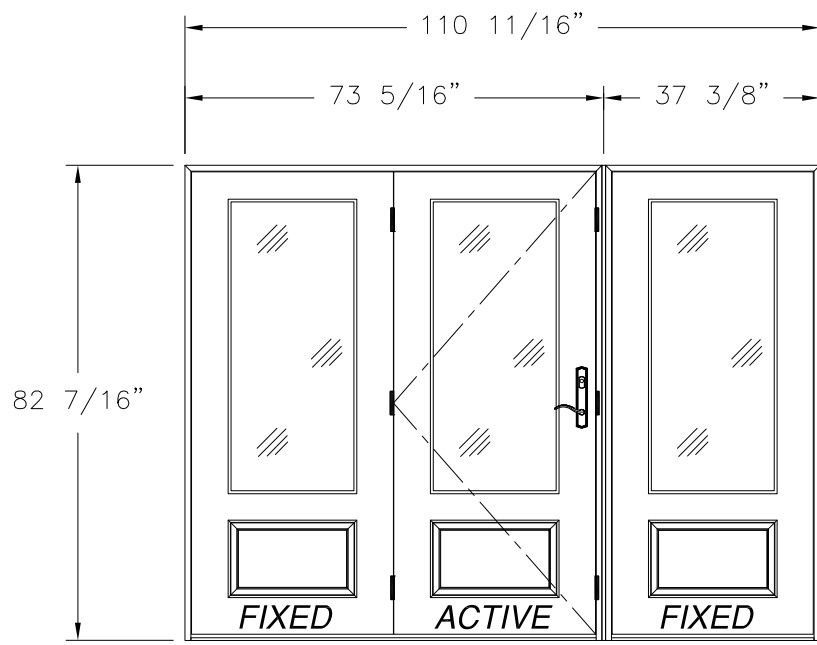

**SINGLE W/SIDELITE (MULL)**  
EXTERIOR VIEW

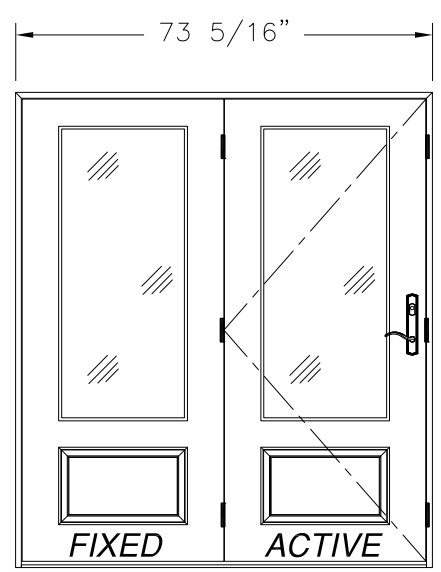

**SINGLE W/SIDELITE**  
EXTERIOR VIEW

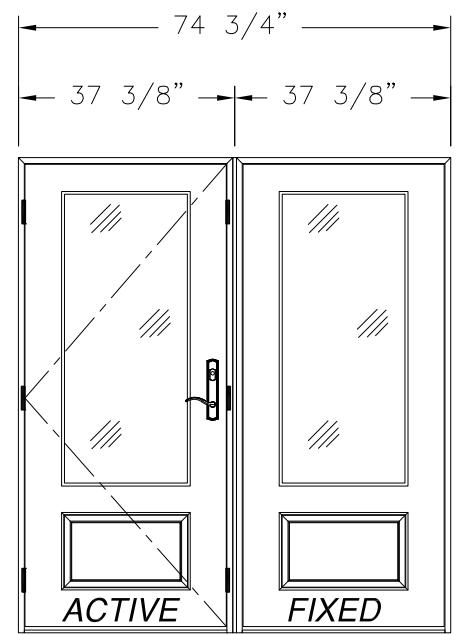

**SINGLE W/SIDELITE (MULL)**  
EXTERIOR VIEW

NOTE:  
ALL APPROVED CONFIGURATIONS ARE SHOWN AS LEFT  
HAND ACTIVE, RIGHT HAND ACTIVE IS ALSO APPROVED.

SIGNED: 03/25/2022

NAN YA PLASTICS CORPORATION U.S.A.  
8989 NORTH LOOP EAST  
HOUSTON, TX 77029

SERIES "SLPS" GLAZED FIBERGLASS INSWING  
SIDE-HINGED DOOR W/SIDELITES - IMPACT  
APPROVED CONFIGURATIONS 3/4 LITE PANEL

DRAWN: A.R.	DWG NO. 08-03313	REV B
SCALE NTS	DATE 09/27/18	SHEET 4 OF 17

L. ROBERTO LOMAS P.E.  
400 S. PALM AVE, INDIALANTIC, FL 32903  
434-688-0609 rllomas@rlomaspe.com



Luis R. Lomas P.E.  
TX No.: 101889  
Firm No: F-23130

REVISIONS			
REV	DESCRIPTION	DATE	APPROVED
A	REVISED TO ADD 3/4 LITE PANEL	02/11/2021	R.L.
B	REVISED TO ADD INSTALLATION DETAILS	03/15/2022	R.L.

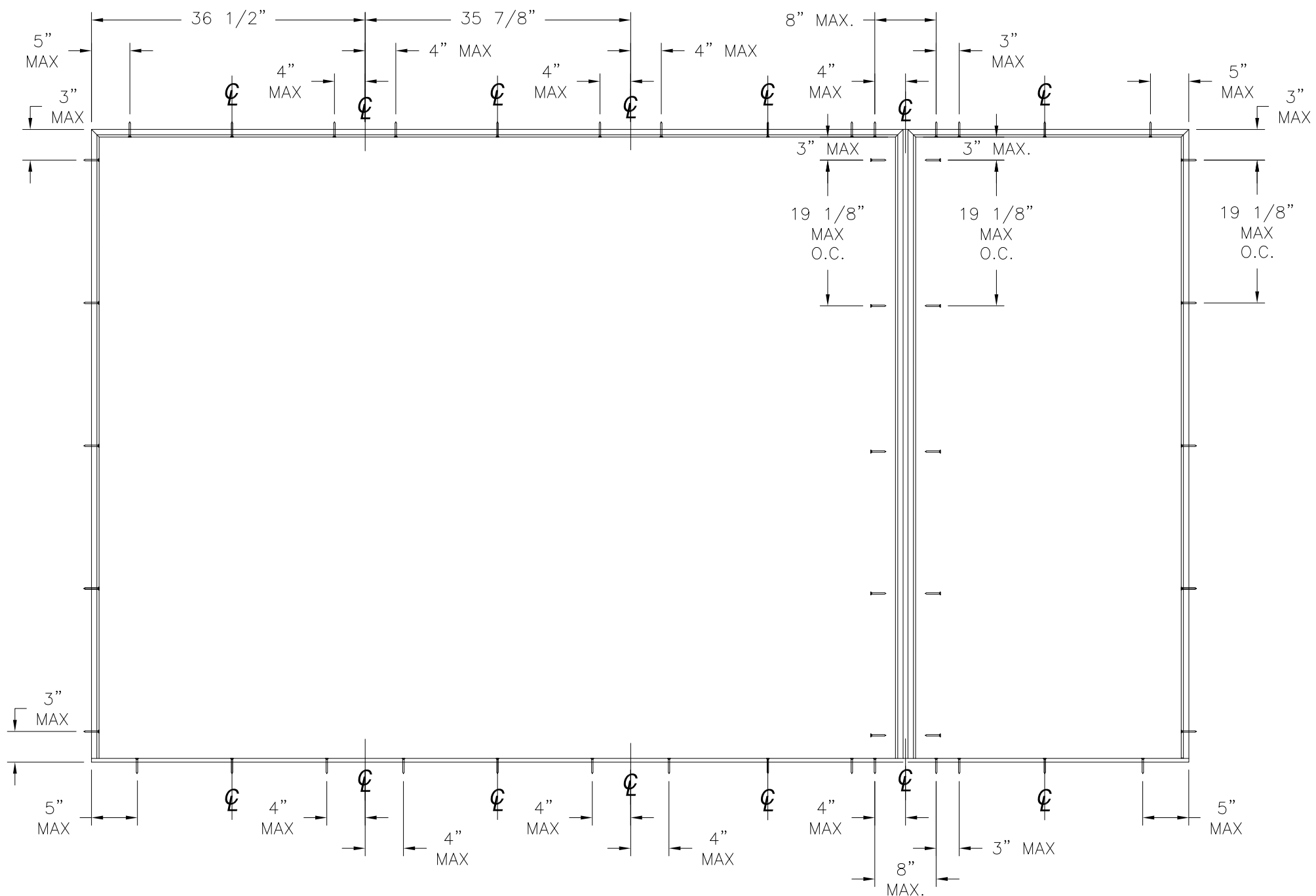

ANCHORING LAYOUT

SIGNED: 03/25/2022

NAN YA PLASTICS CORPORATION U.S.A.  
 8989 NORTH LOOP EAST  
 HOUSTON, TX 77029

SERIES "SLPS" GLAZED FIBERGLASS INSWING  
 SIDE-HINGED DOOR W/SIDELITES - IMPACT  
 ANCHORING LAYOUT

DRAWN: A.R.	DWG NO. 08-03313	REV B
SCALE NTS	DATE 09/27/18	SHEET 5 OF 17

L. ROBERTO LOMAS P.E.  
 400 S. PALM AVE, INDIALANTIC, FL 32903  
 434-688-0609 rllomas@rlomaspe.com



Luis R. Lomas P.E.  
 TX No.: 101889  
 Firm No: F-23130

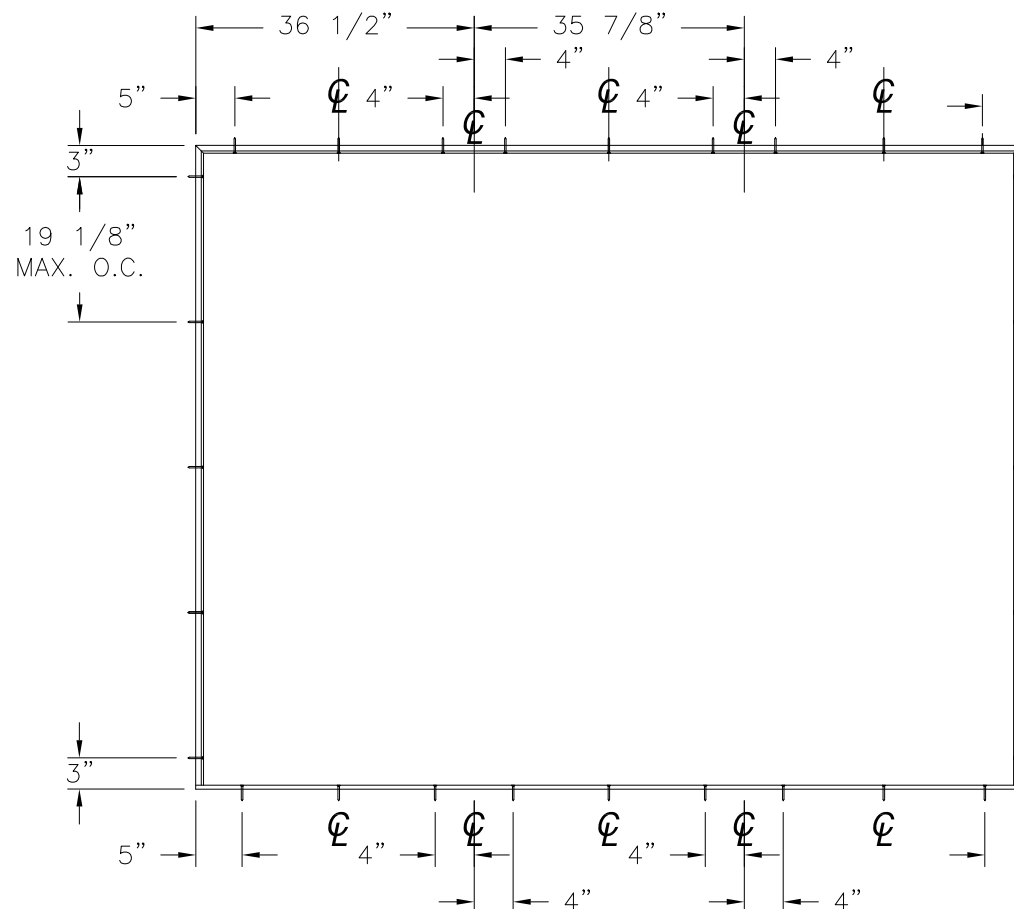

**ANCHORING LAYOUT FOR OXO, XXO AND OXX**

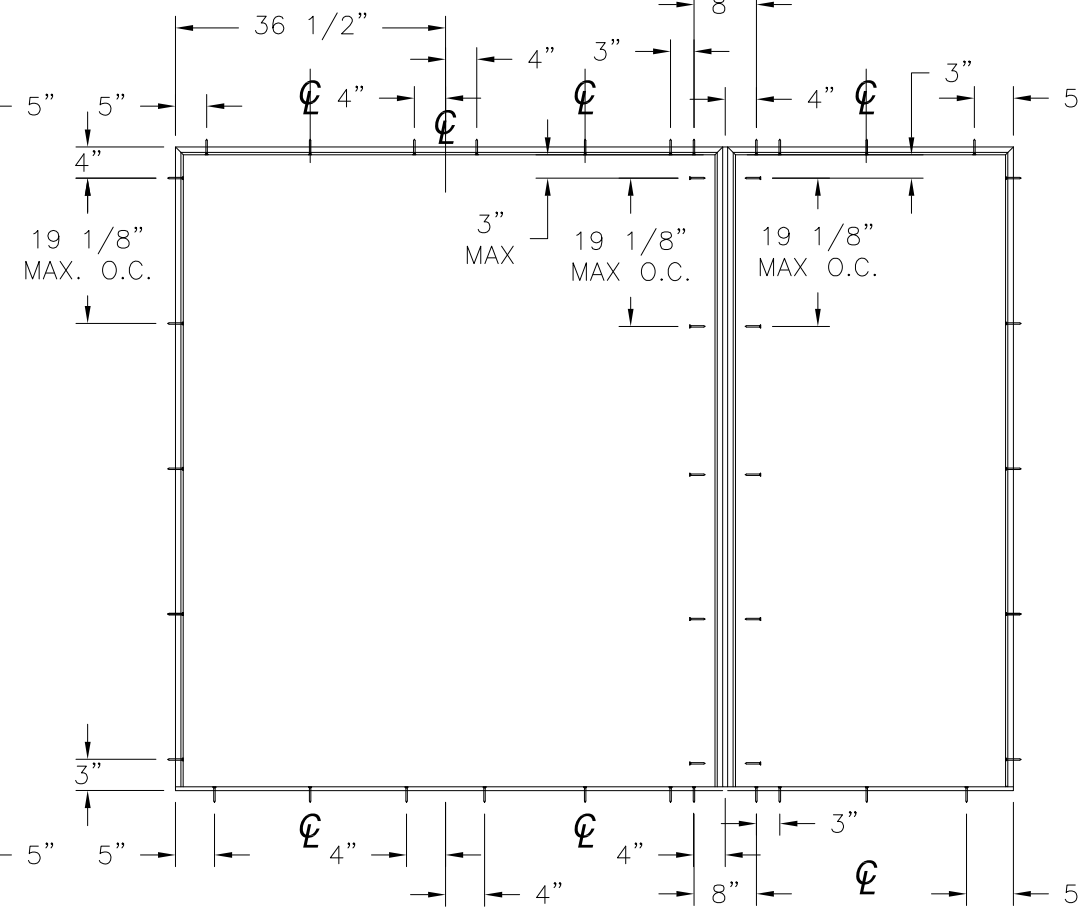

**ANCHORING LAYOUT FOR OXO, XXO AND OXX (MULL)**

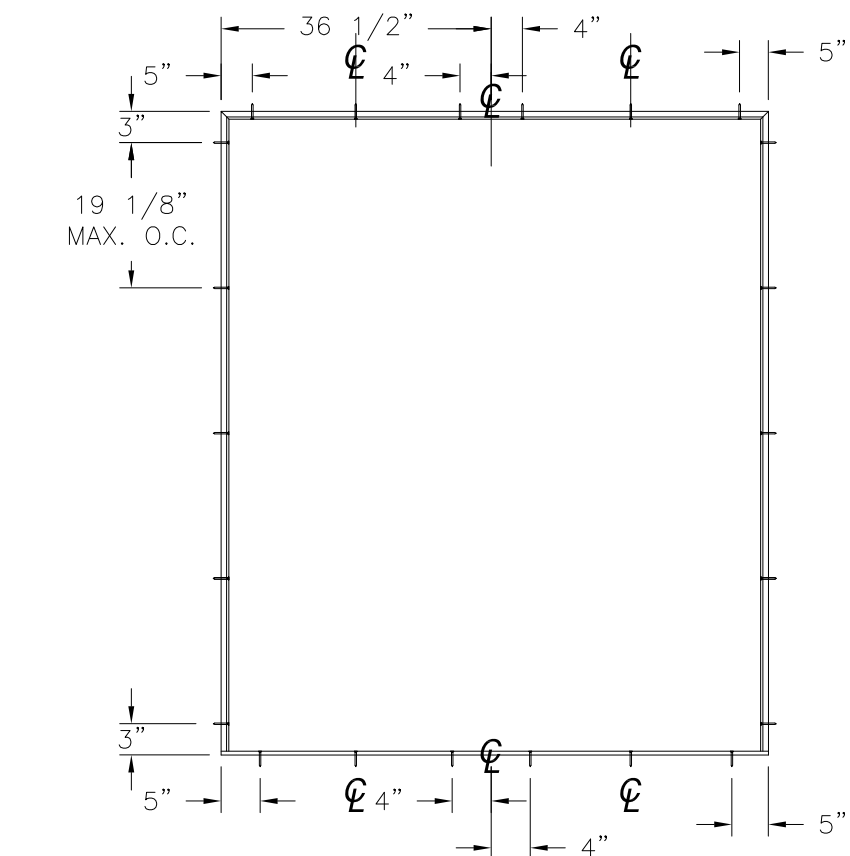

**ANCHORING LAYOUT FOR XX, OX AND XO**

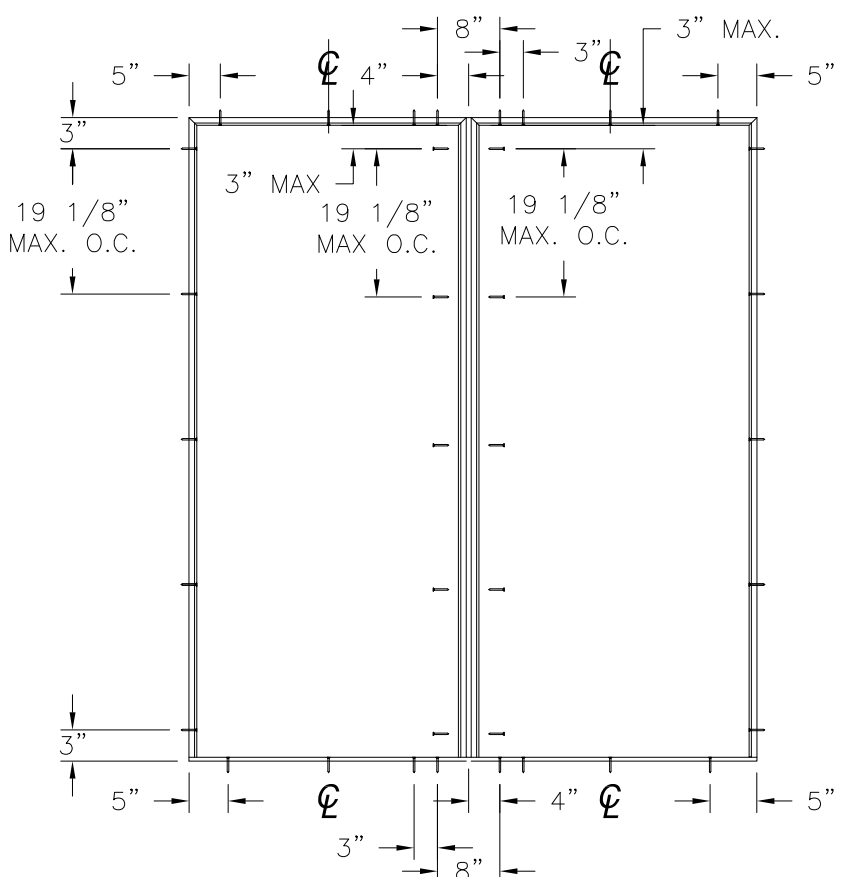

**ANCHORING LAYOUT FOR OX AND XO (MULL)**

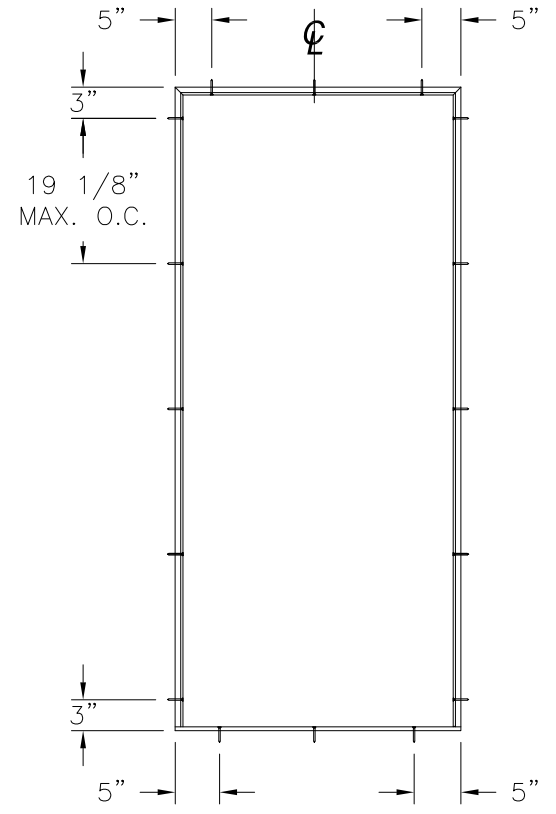

**ANCHORING LAYOUT FOR X**

REVISIONS			
REV	DESCRIPTION	DATE	APPROVED
A	REVISED TO ADD 3/4 LITE PANEL	02/11/2021	R.L.
B	REVISED TO ADD INSTALLATION DETAILS	03/15/2022	R.L.

**NAN YA PLASTICS CORPORATION U.S.A.**  
 8989 NORTH LOOP EAST  
 HOUSTON, TX 77029

SERIES "SLPS" GLAZED FIBERGLASS INSWING  
 SIDE-HINGED DOOR W/SIDELITES - IMPACT  
 ANCHORING LAYOUTS

DRAWN: A.R.	DWG NO. 08-03313	REV B
SCALE NTS	DATE 09/27/18	SHEET 6 OF 17

L. ROBERTO LOMAS P.E.  
 400 S. PALM AVE, INDIALANTIC, FL 32903  
 434-688-0609 rllomas@rlomaspe.com

SIGNED: 03/25/2022



Luis R. Lomas P.E.  
 TX No.: 101889  
 Firm No: F-23130

REVISIONS			
REV	DESCRIPTION	DATE	APPROVED
A	REVISED TO ADD 3/4 LITE PANEL	02/11/2021	R.L.
B	REVISED TO ADD INSTALLATION DETAILS	03/15/2022	R.L.

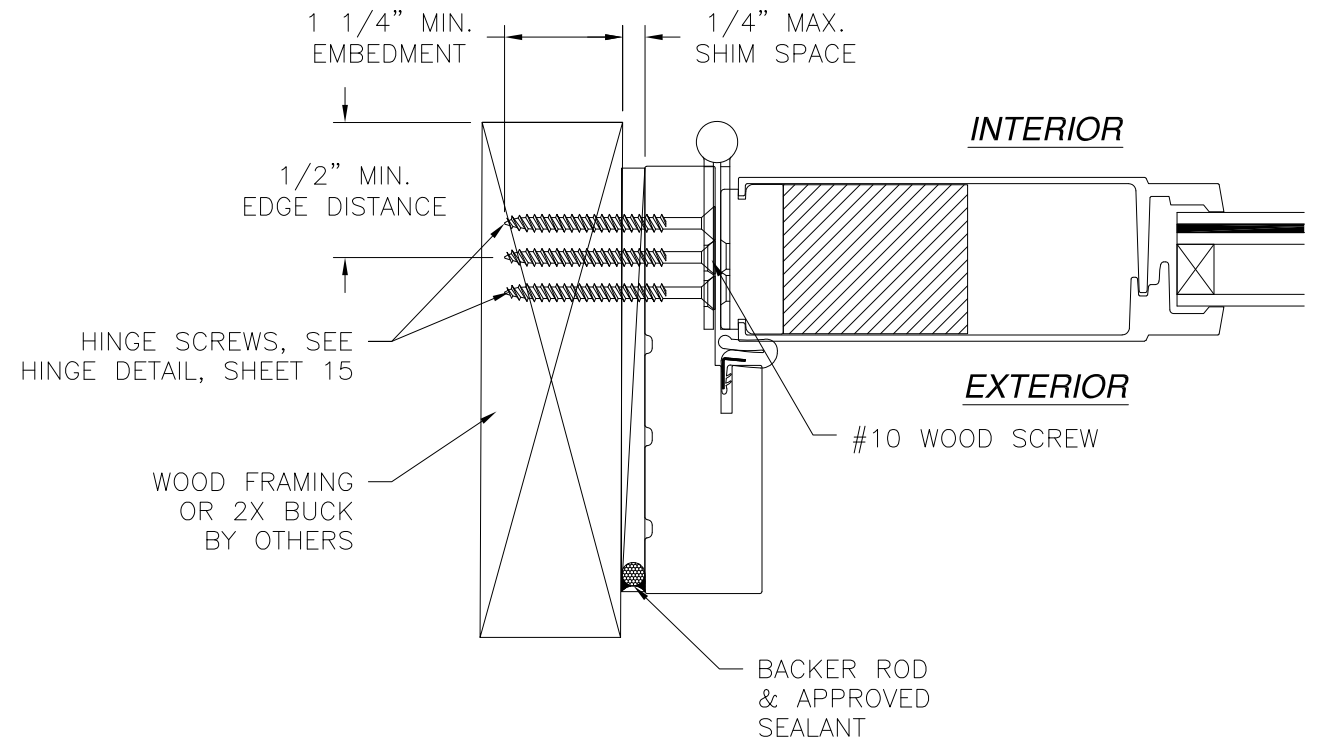
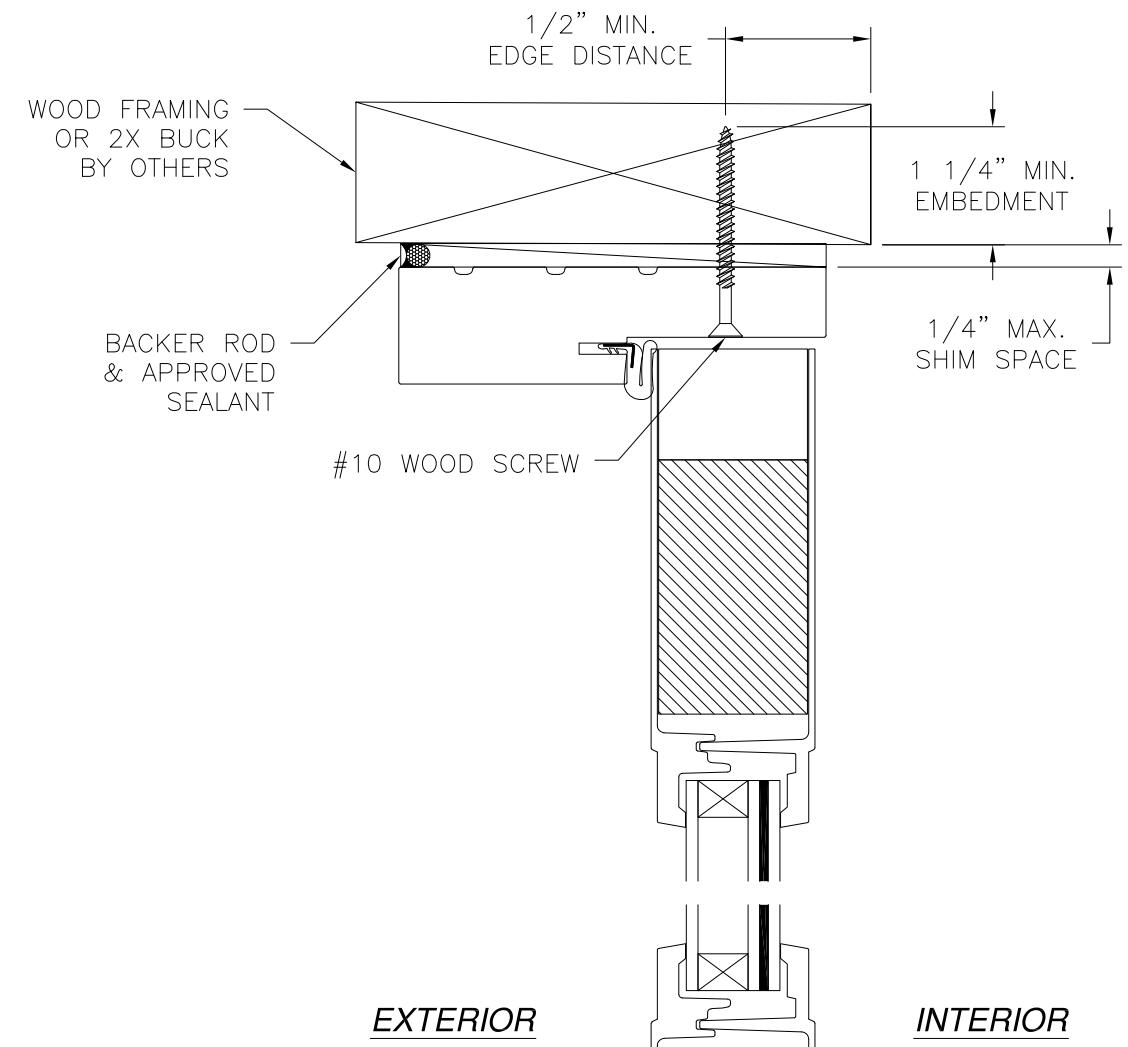

**DOOR INSTALLATION DETAIL**  
WOOD FRAMING OR 2X BUCK INSTALLATION

- NOTES:**
1. INTERIOR AND EXTERIOR FINISHES, BY OTHERS, NOT SHOWN FOR CLARITY.
  2. PERIMETER AND JOINT SEALANT BY OTHERS TO BE DESIGNED IN ACCORDANCE WITH ASTM E2112

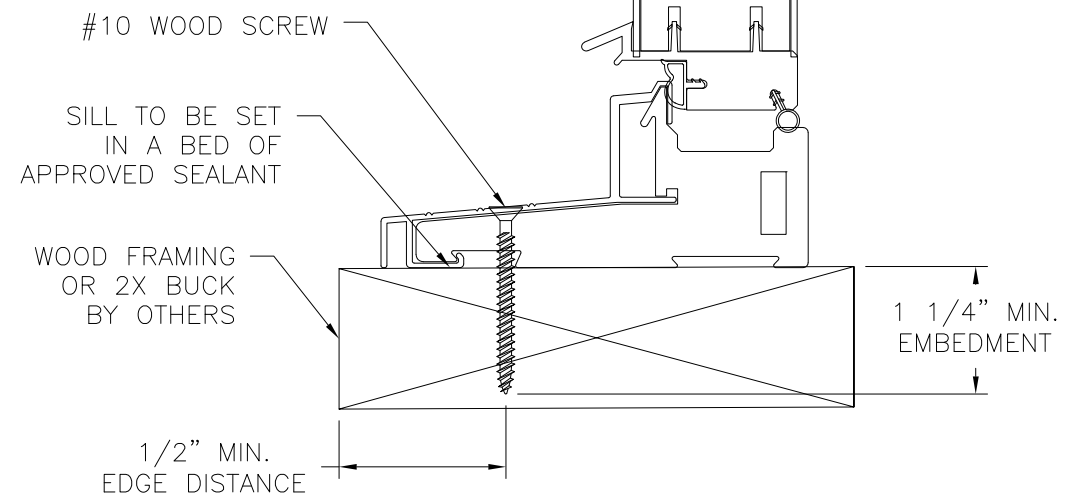

**DOOR INSTALLATION DETAIL**  
2X BUCK/WOOD FRAMING INSTALLATION

SIGNED: 03/25/2022

NAN YA PLASTICS CORPORATION U.S.A.  
8989 NORTH LOOP EAST  
HOUSTON, TX 77029

SERIES "SLPS" GLAZED FIBERGLASS INSWING  
SIDE-HINGED DOOR W/SIDELITES - IMPACT  
DOOR INSTALLATION DETAILS

DRAWN: A.R.	DWG NO. 08-03313	REV B
SCALE NTS	DATE 09/27/18	SHEET 7 OF 17

L. ROBERTO LOMAS P.E.  
400 S. PALM AVE, INDIALANTIC, FL 32903  
434-688-0609 rllomas@rlomaspe.com



Luis R. Lomas P.E.  
TX No.: 101889  
Firm No: F-23130

REVISIONS			
REV	DESCRIPTION	DATE	APPROVED
A	REVISED TO ADD 3/4 LITE PANEL	02/11/2021	R.L.
B	REVISED TO ADD INSTALLATION DETAILS	03/15/2022	R.L.

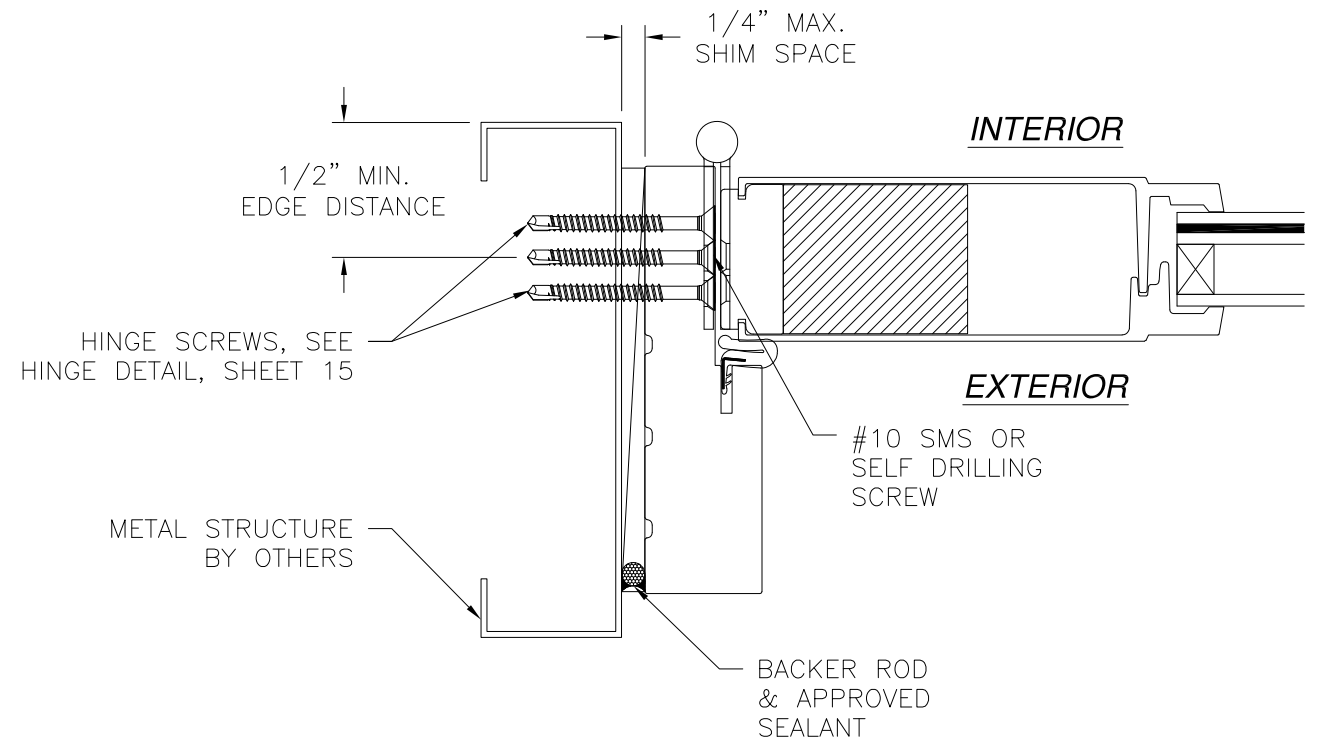
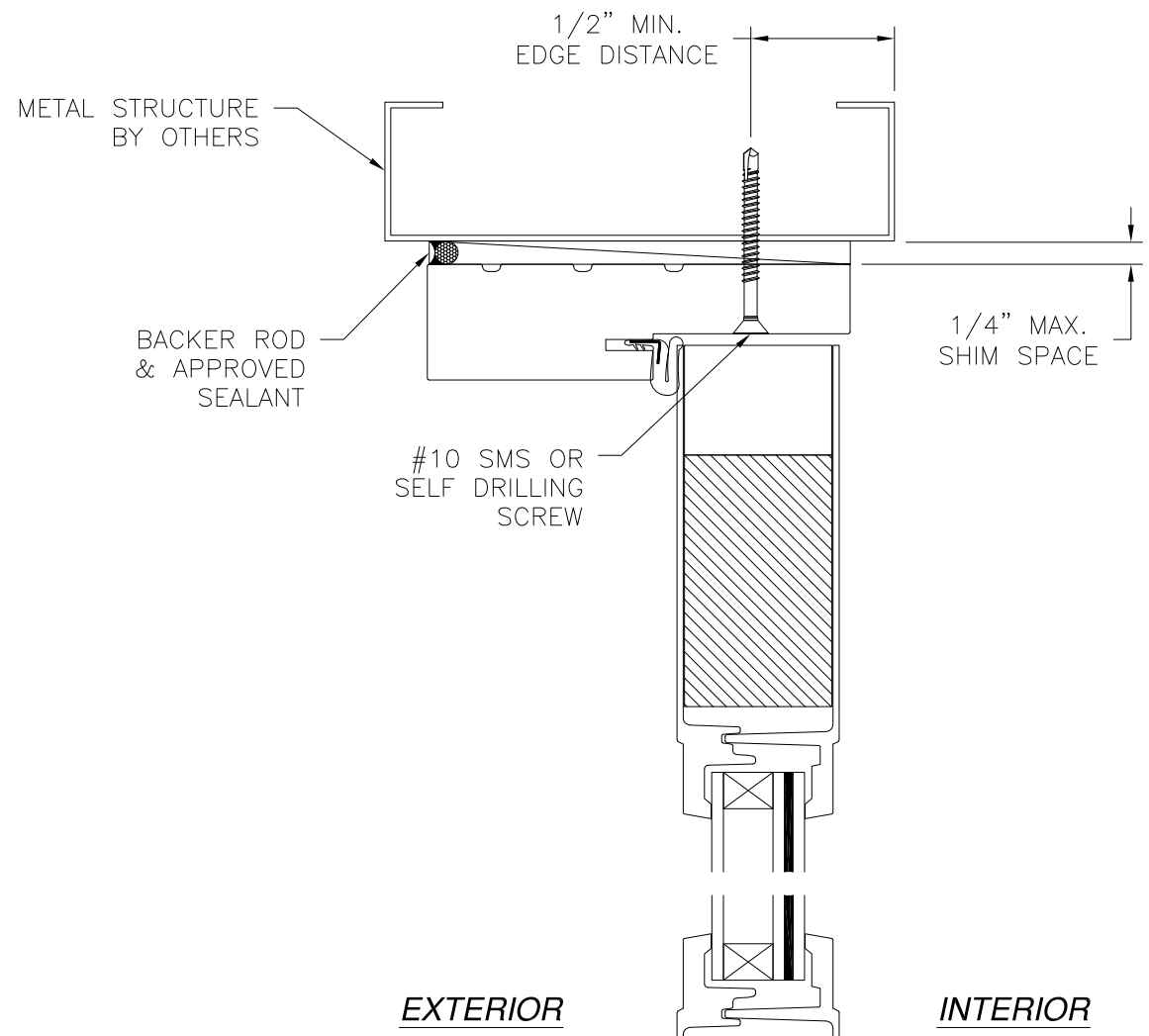

**DOOR INSTALLATION DETAIL**  
METAL STRUCTURE INSTALLATION

- NOTES:**
1. INTERIOR AND EXTERIOR FINISHES, BY OTHERS, NOT SHOWN FOR CLARITY.
  2. PERIMETER AND JOINT SEALANT BY OTHERS TO BE DESIGNED IN ACCORDANCE WITH ASTM E2112

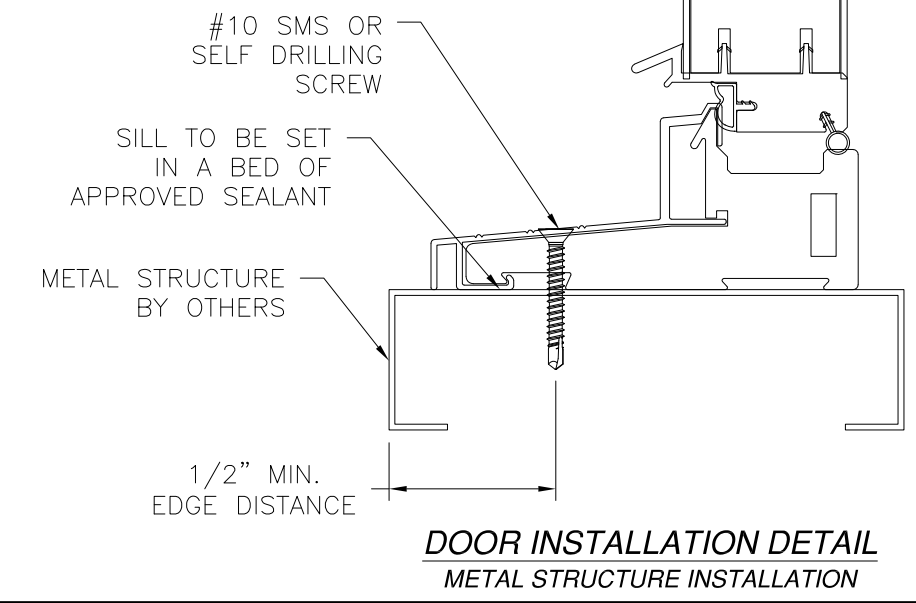

**DOOR INSTALLATION DETAIL**  
METAL STRUCTURE INSTALLATION

SIGNED: 03/25/2022

NAN YA PLASTICS CORPORATION U.S.A.  
8989 NORTH LOOP EAST  
HOUSTON, TX 77029

SERIES "SLPS" GLAZED FIBERGLASS INSWING  
SIDE-HINGED DOOR W/SIDELITES - IMPACT  
DOOR INSTALLATION DETAILS

DRAWN: A.R.	DWG NO. 08-03313	REV B
SCALE NTS	DATE 09/27/18	SHEET 8 OF 17

L. ROBERTO LOMAS P.E.  
400 S. PALM AVE, INDIALANTIC, FL 32903  
434-688-0609 rllomas@rlomaspe.com



Luis R. Lomas P.E.  
TX No.: 101889  
Firm No: F-23130



REVISIONS			
REV	DESCRIPTION	DATE	APPROVED
A	REVISED TO ADD 3/4 LITE PANEL	02/11/2021	R.L.
B	REVISED TO ADD INSTALLATION DETAILS	03/15/2022	R.L.

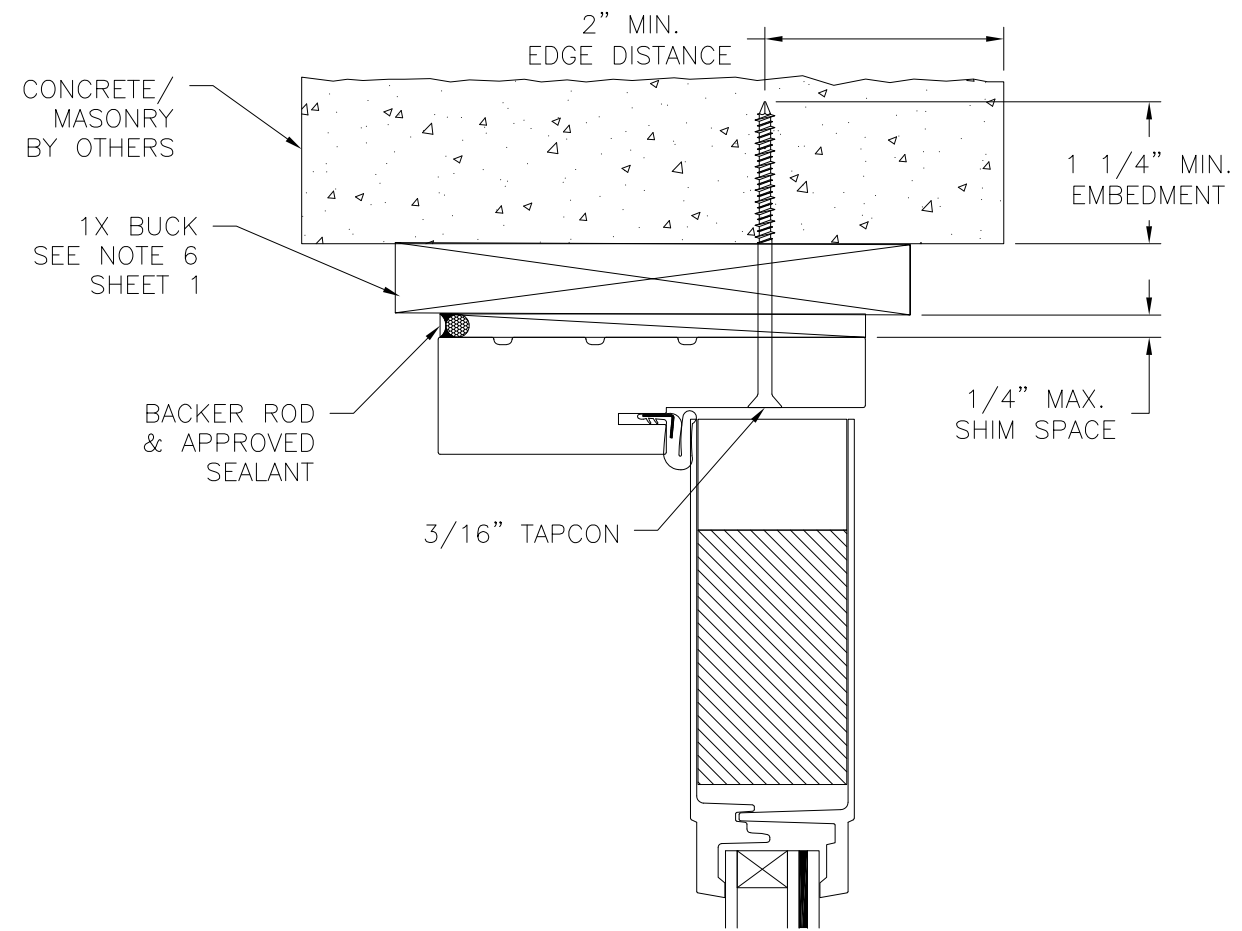

**EXTERIOR** **INTERIOR**

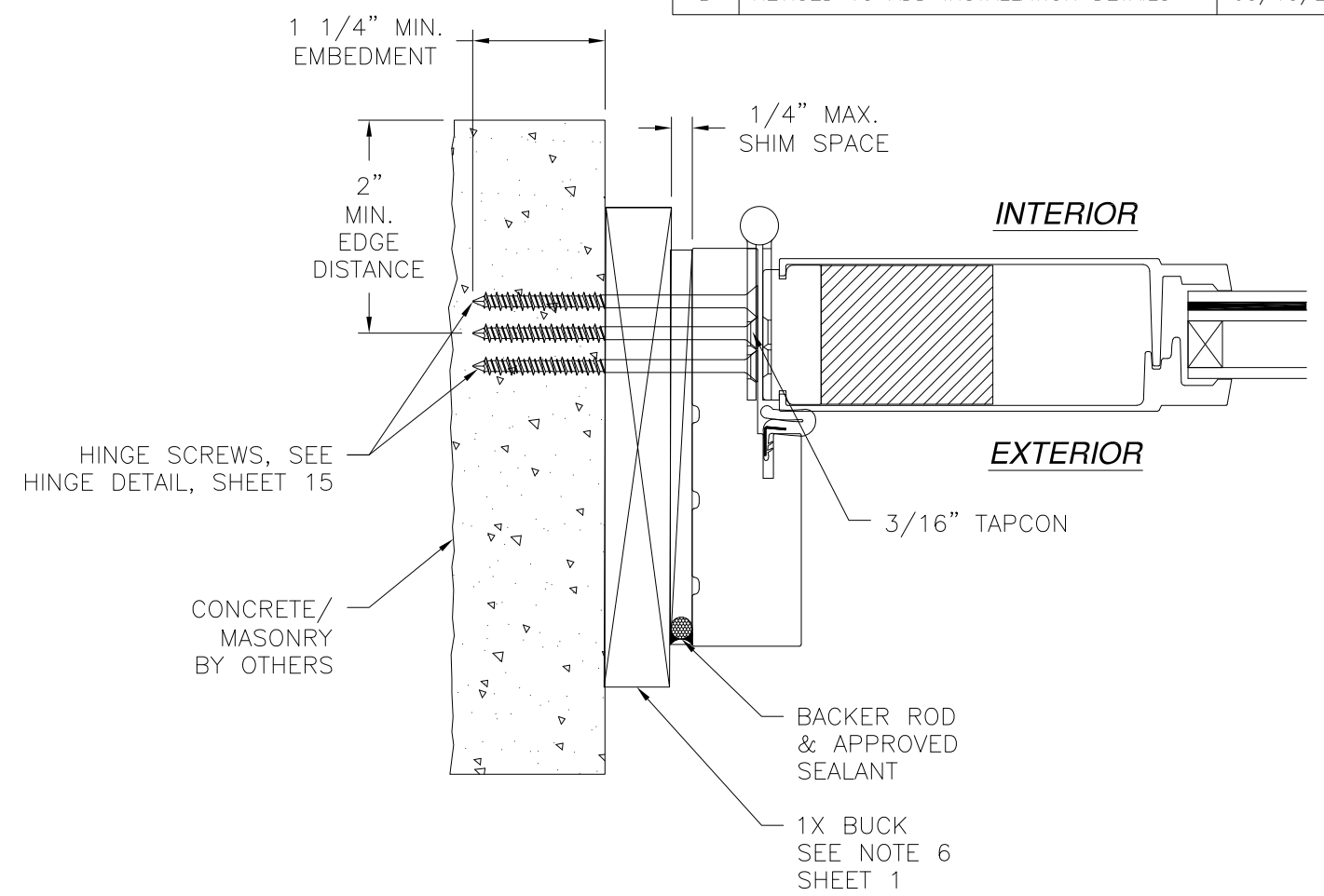

**DOOR INSTALLATION DETAIL**  
CONCRETE/MASONRY W/1X BUCK INSTALLATION

- NOTES:**
1. INTERIOR AND EXTERIOR FINISHES, BY OTHERS, NOT SHOWN FOR CLARITY.
  2. PERIMETER AND JOINT SEALANT BY OTHERS TO BE DESIGNED IN ACCORDANCE WITH ASTM E2112

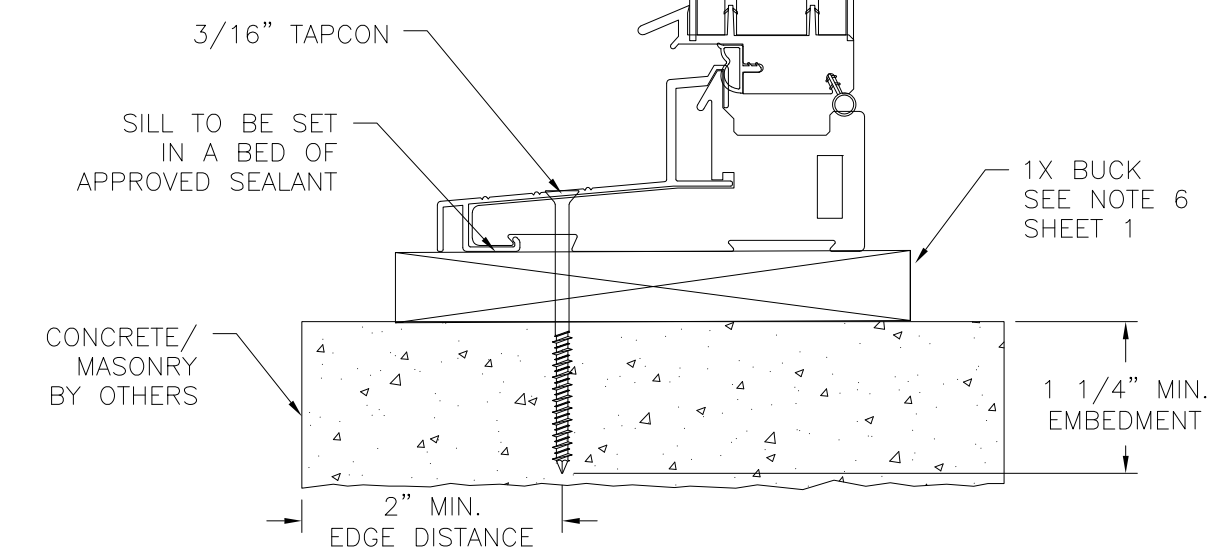

**DOOR INSTALLATION DETAIL**  
CONCRETE/MASONRY W/1X BUCK INSTALLATION

SIGNED: 03/25/2022

**NAN YA PLASTICS CORPORATION U.S.A.**  
8989 NORTH LOOP EAST  
HOUSTON, TX 77029

SERIES "SLPS" GLAZED FIBERGLASS INSWING  
SIDE-HINGED DOOR W/SIDELITES - IMPACT  
DOOR INSTALLATION DETAILS

DRAWN: A.R.	DWG NO. 08-03313	REV B
SCALE NTS	DATE 09/27/18	SHEET 9 OF 17

L. ROBERTO LOMAS P.E.  
400 S. PALM AVE, INDIALANTIC, FL 32903  
434-688-0609 rllomas@rllomaspe.com



Luis R. Lomas P.E.  
TX No.: 101889  
Firm No: F-23130

REVISIONS			
REV	DESCRIPTION	DATE	APPROVED
A	REVISED TO ADD 3/4 LITE PANEL	02/11/2021	R.L.
B	REVISED TO ADD INSTALLATION DETAILS	03/15/2022	R.L.

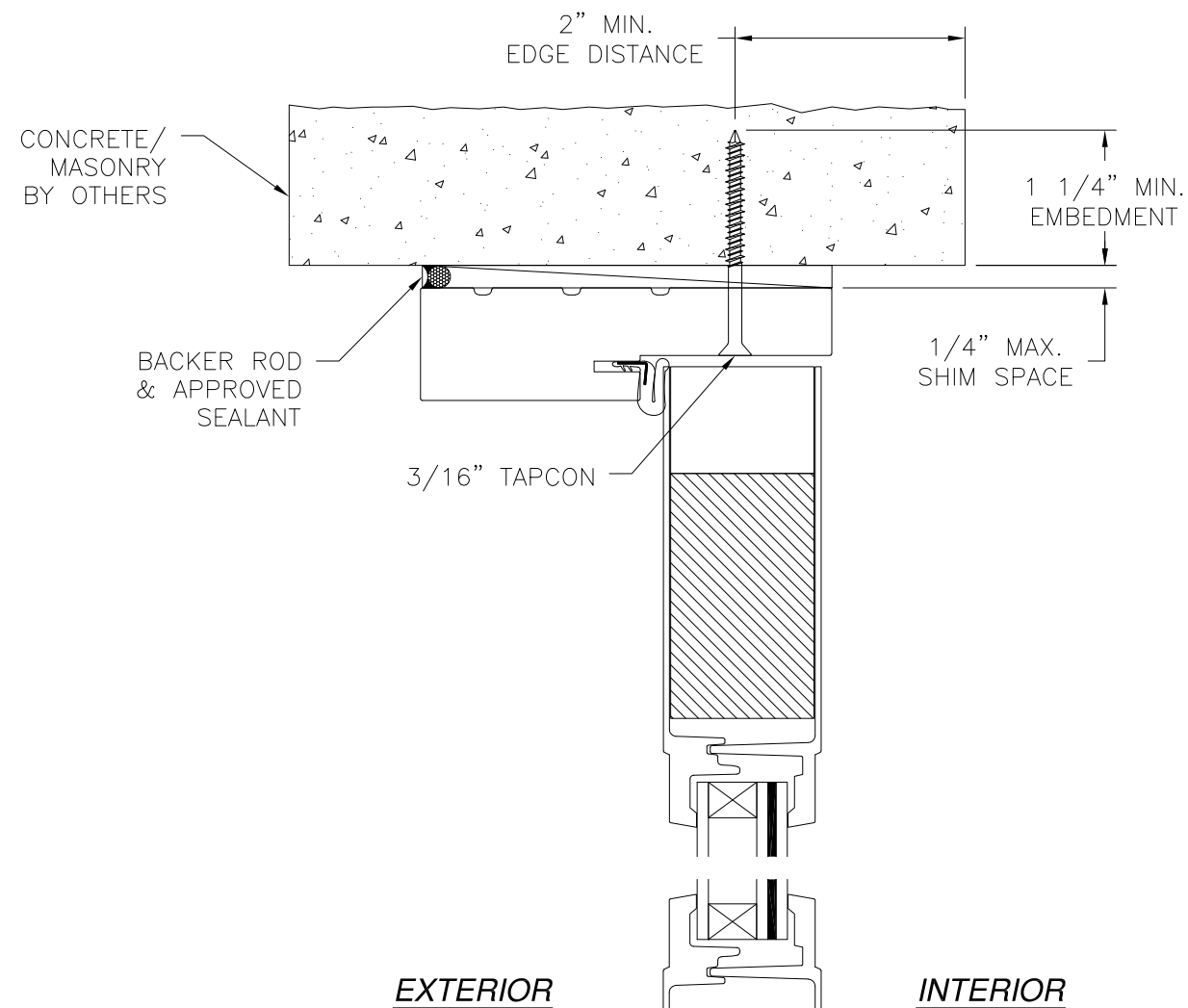

EXTERIOR

INTERIOR

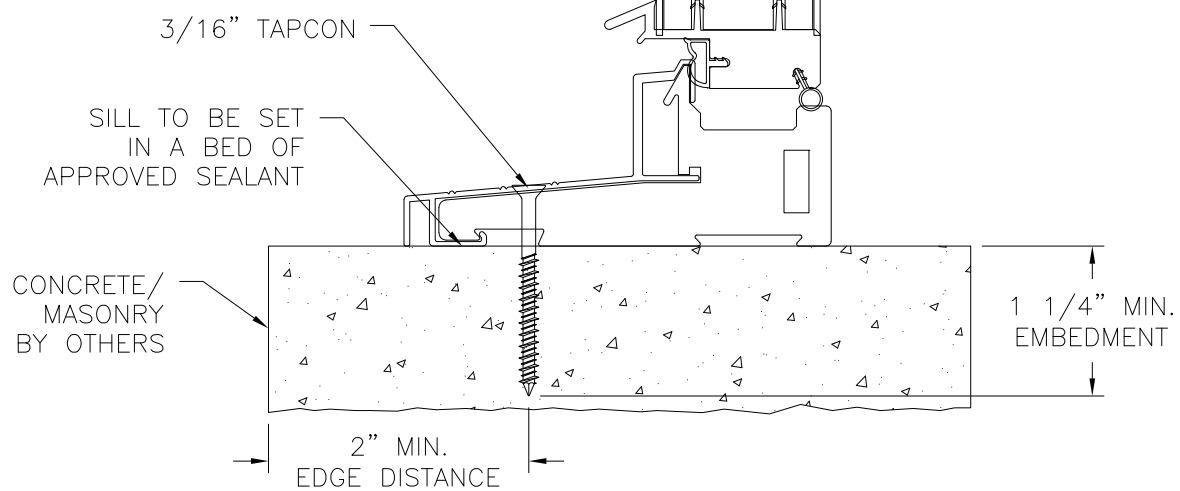

**DOOR INSTALLATION DETAIL**  
**CONCRETE/MASONRY INSTALLATION**

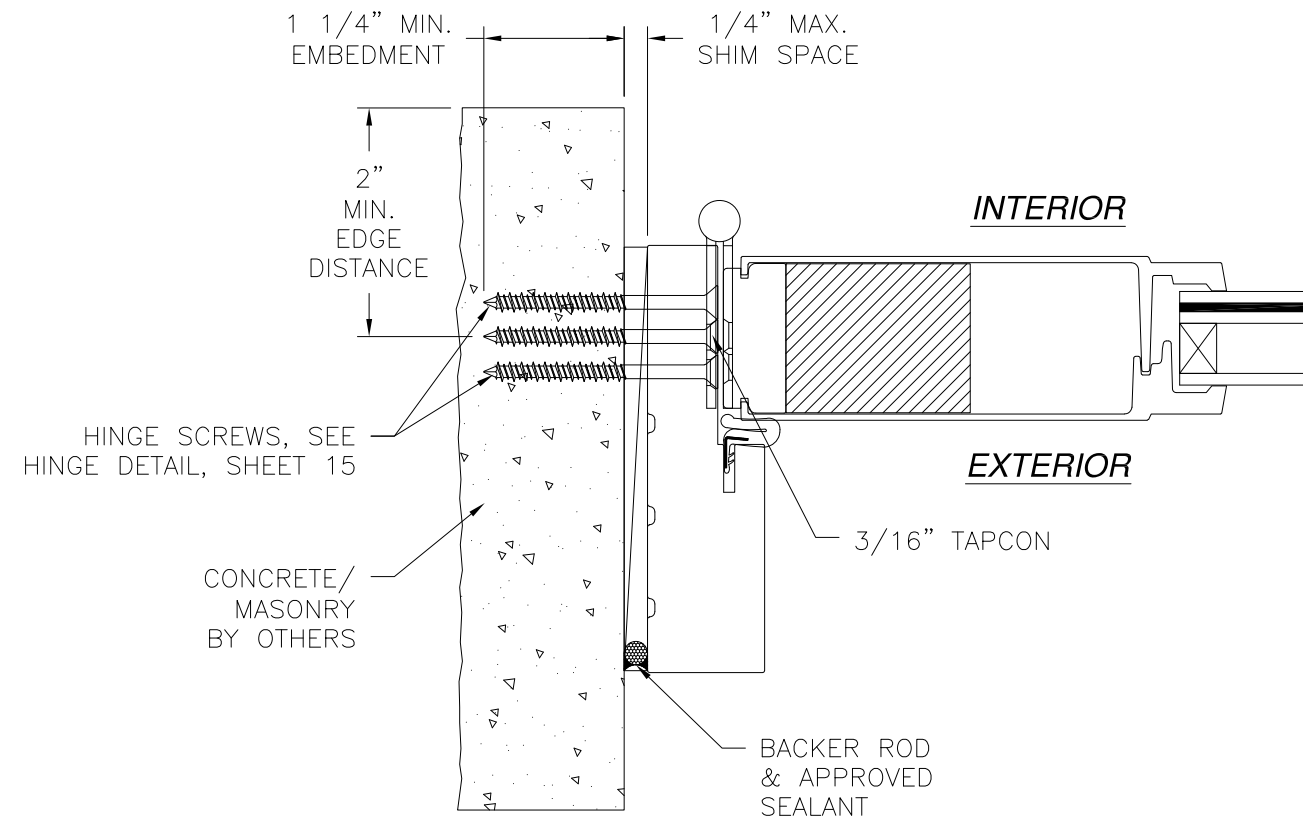

**DOOR INSTALLATION DETAIL**  
**CONCRETE/MASONRY INSTALLATION**

**NOTES:**

1. INTERIOR AND EXTERIOR FINISHES, BY OTHERS, NOT SHOWN FOR CLARITY.
2. PERIMETER AND JOINT SEALANT BY OTHERS TO BE DESIGNED IN ACCORDANCE WITH ASTM E2112

SIGNED: 03/25/2022

NAN YA PLASTICS CORPORATION U.S.A.  
8989 NORTH LOOP EAST  
HOUSTON, TX 77029

SERIES "SLPS" GLAZED FIBERGLASS INSWING  
SIDE-HINGED DOOR W/SIDELITES - IMPACT  
DOOR INSTALLATION DETAILS

DRAWN: A.R.	DWG NO. 08-03313	REV B
----------------	---------------------	----------

SCALE NTS	DATE 09/27/18	SHEET 10 OF 17
--------------	------------------	-------------------

L. ROBERTO LOMAS P.E.  
400 S. PALM AVE, INDIALANTIC, FL 32903  
434-688-0609 rllomas@rlomaspe.com



Luis R. Lomas P.E.  
TX No.: 101889  
Firm No: F-23130

REVISIONS			
REV	DESCRIPTION	DATE	APPROVED
A	REVISED TO ADD 3/4 LITE PANEL	02/11/2021	R.L.
B	REVISED TO ADD INSTALLATION DETAILS	03/15/2022	R.L.

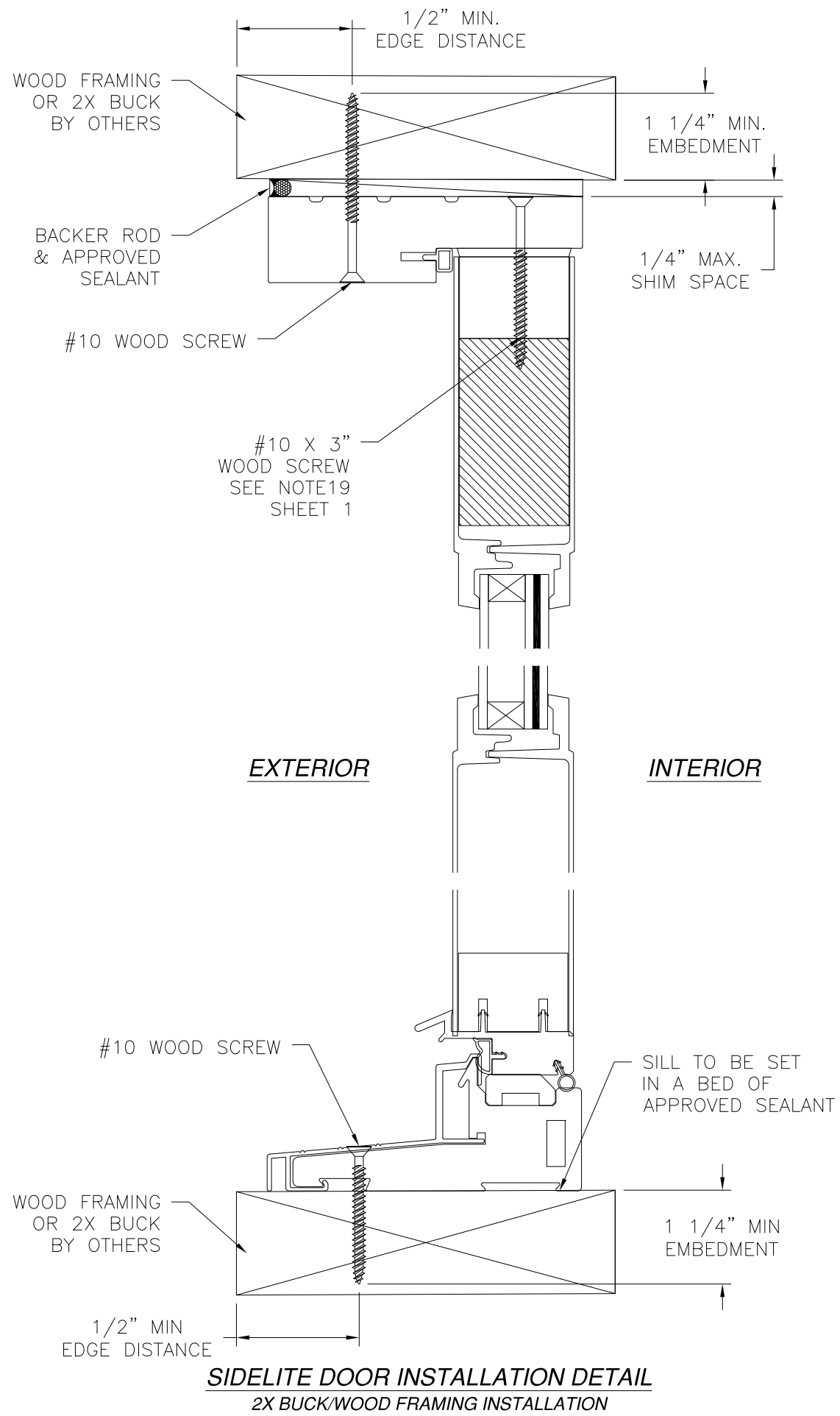

**SIDELITE DOOR INSTALLATION DETAIL**  
2X BUCK/WOOD FRAMING INSTALLATION

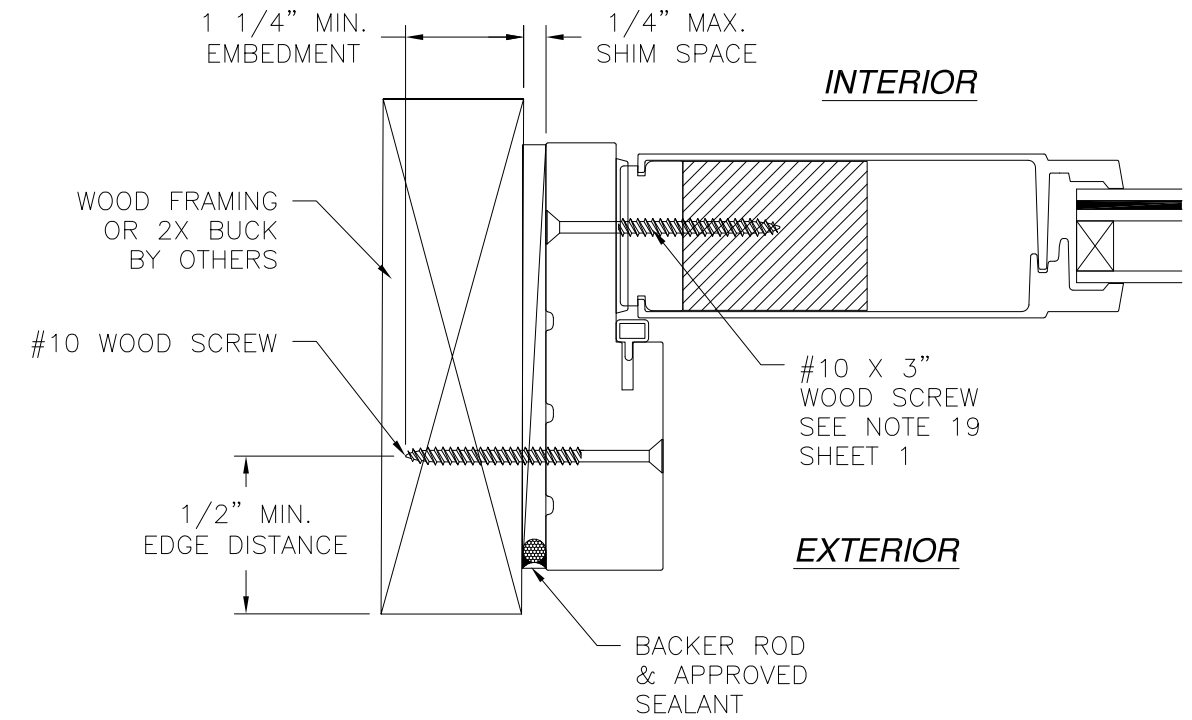

**SIDELITE INSTALLATION DETAIL**  
WOOD FRAMING OR 2X BUCK INSTALLATION

- NOTES:**
1. INTERIOR AND EXTERIOR FINISHES, BY OTHERS, NOT SHOWN FOR CLARITY.
  2. PERIMETER AND JOINT SEALANT BY OTHERS TO BE DESIGNED IN ACCORDANCE WITH ASTM E2112

SIGNED: 03/25/2022

NAN YA PLASTICS CORPORATION U.S.A.  
8989 NORTH LOOP EAST  
HOUSTON, TX 77029

SERIES "SLPS" GLAZED FIBERGLASS INSWING  
SIDE-HINGED DOOR W/SIDELITES - IMPACT  
SIDELITE INSTALLATION DETAILS

DRAWN: A.R.	DWG NO. 08-03313	REV B
SCALE NTS	DATE 09/27/18	SHEET 11 OF 17

L. ROBERTO LOMAS P.E.  
400 S. PALM AVE, INDIALANTIC, FL 32903  
434-688-0609 rllomas@rlomaspe.com



Luis R. Lomas P.E.  
TX No.: 101889  
Firm No: F-23130

REVISIONS			
REV	DESCRIPTION	DATE	APPROVED
A	REVISED TO ADD 3/4 LITE PANEL	02/11/2021	R.L.
B	REVISED TO ADD INSTALLATION DETAILS	03/15/2022	R.L.

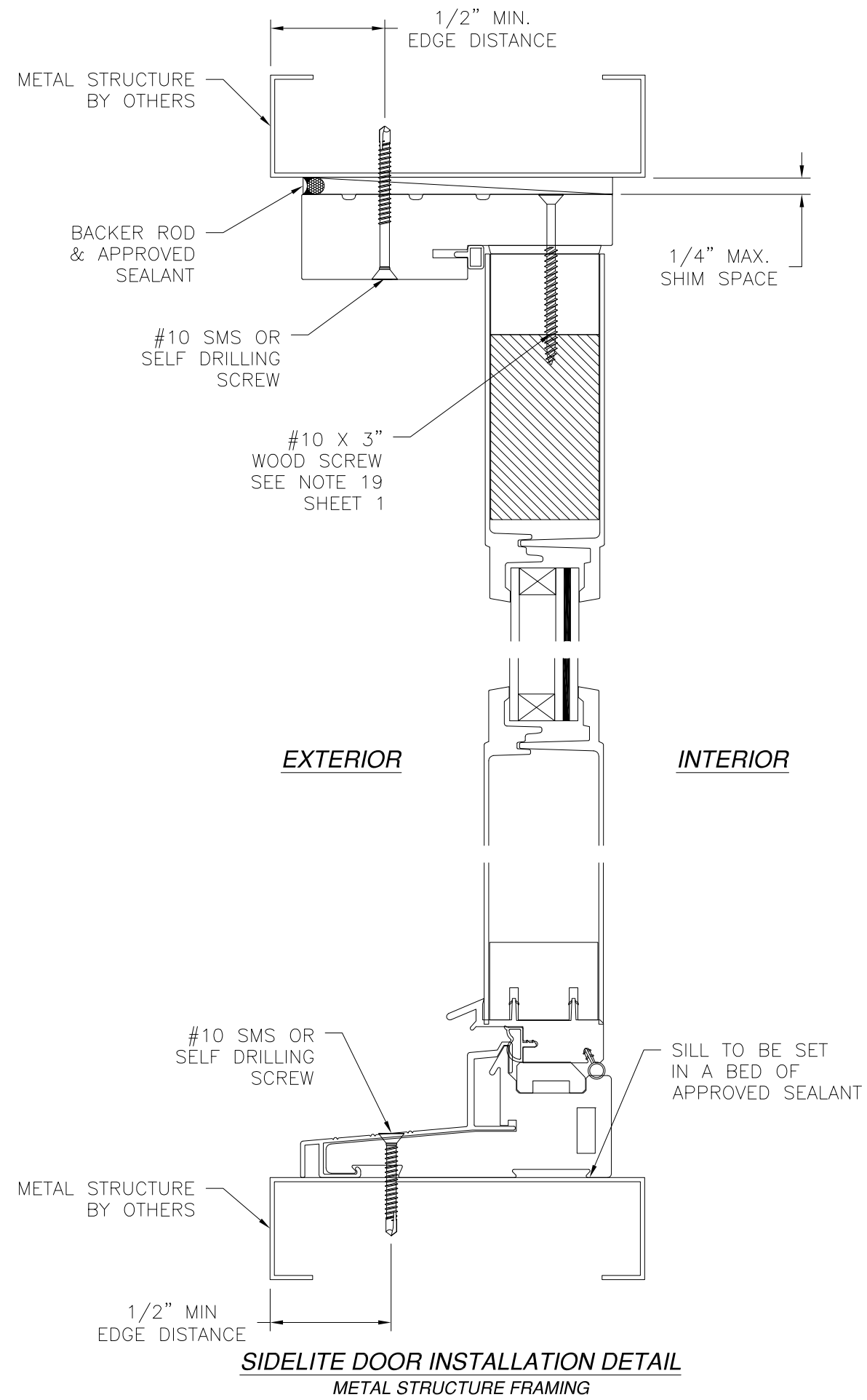

**SIDELITE DOOR INSTALLATION DETAIL**  
METAL STRUCTURE FRAMING

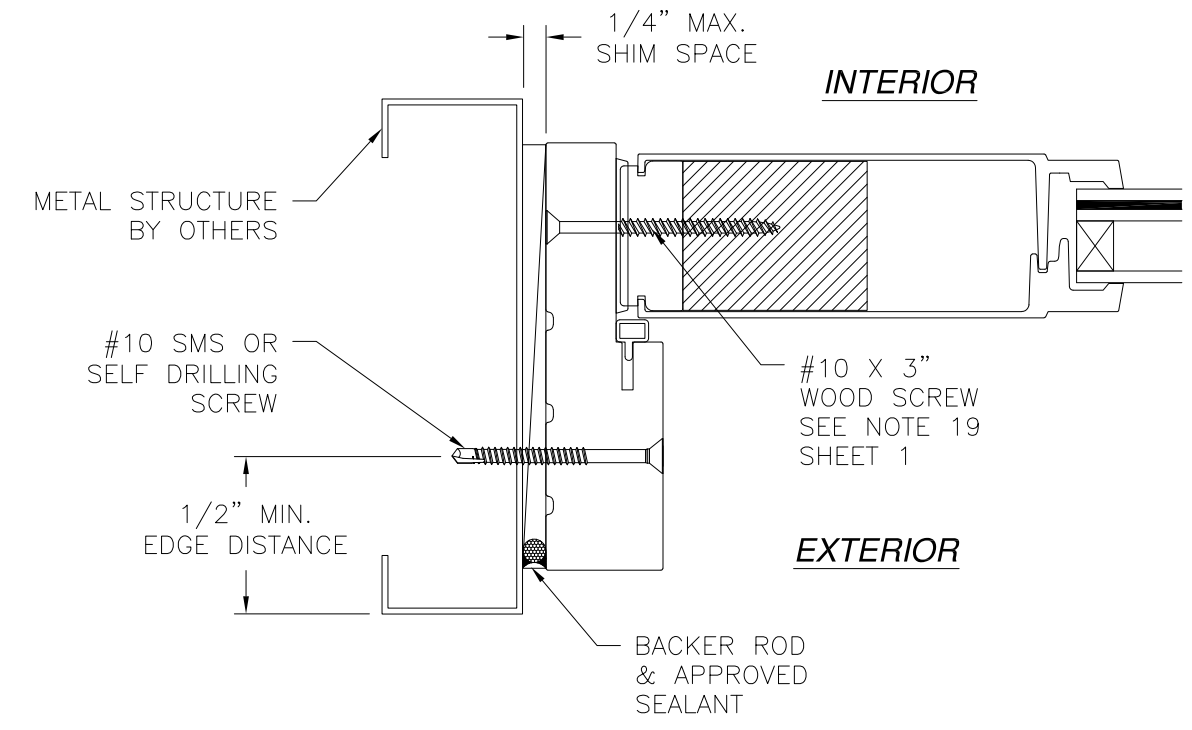

**SIDELITE INSTALLATION DETAIL**  
METAL STRUCTURE INSTALLATION

- NOTES:**
1. INTERIOR AND EXTERIOR FINISHES, BY OTHERS, NOT SHOWN FOR CLARITY.
  2. PERIMETER AND JOINT SEALANT BY OTHERS TO BE DESIGNED IN ACCORDANCE WITH ASTM E2112

SIGNED: 03/25/2022

NAN YA PLASTICS CORPORATION U.S.A.  
8989 NORTH LOOP EAST  
HOUSTON, TX 77029

SERIES "SLPS" GLAZED FIBERGLASS INSWING  
SIDE-HINGED DOOR W/SIDELITES - IMPACT  
SIDELITE INSTALLATION DETAILS

DRAWN: A.R.	DWG NO. 08-03313	REV B
SCALE NTS	DATE 09/27/18	SHEET 12 OF 17

L. ROBERTO LOMAS P.E.  
400 S. PALM AVE, INDIALANTIC, FL 32903  
434-688-0609 rllomas@rlomaspe.com



Luis R. Lomas P.E.  
TX No.: 101889  
Firm No: F-23130

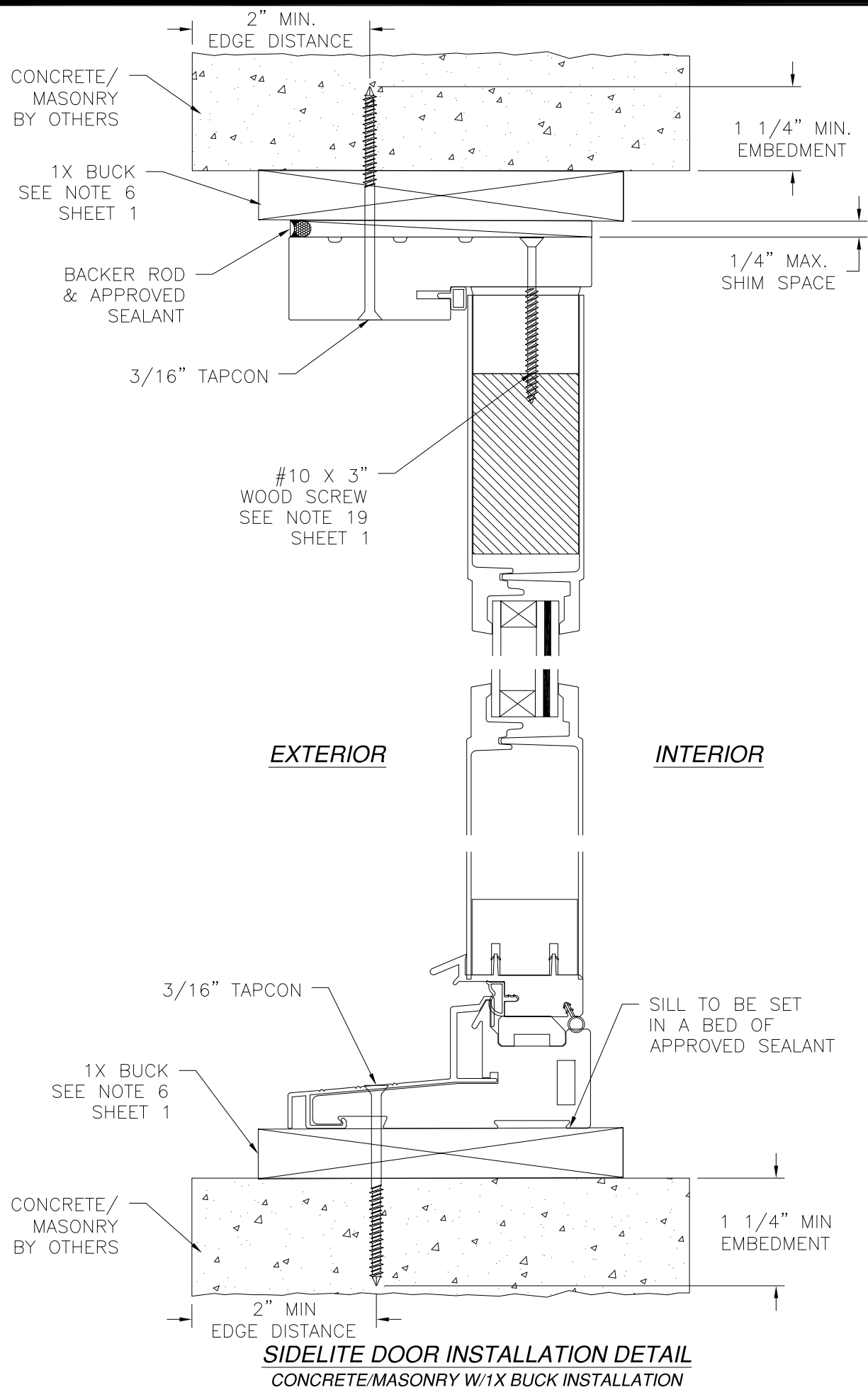

**SIDELITE DOOR INSTALLATION DETAIL**  
 CONCRETE/MASONRY W/1X BUCK INSTALLATION

REVISIONS			
REV	DESCRIPTION	DATE	APPROVED
A	REVISED TO ADD 3/4 LITE PANEL	02/11/2021	R.L.
B	REVISED TO ADD INSTALLATION DETAILS	03/15/2022	R.L.

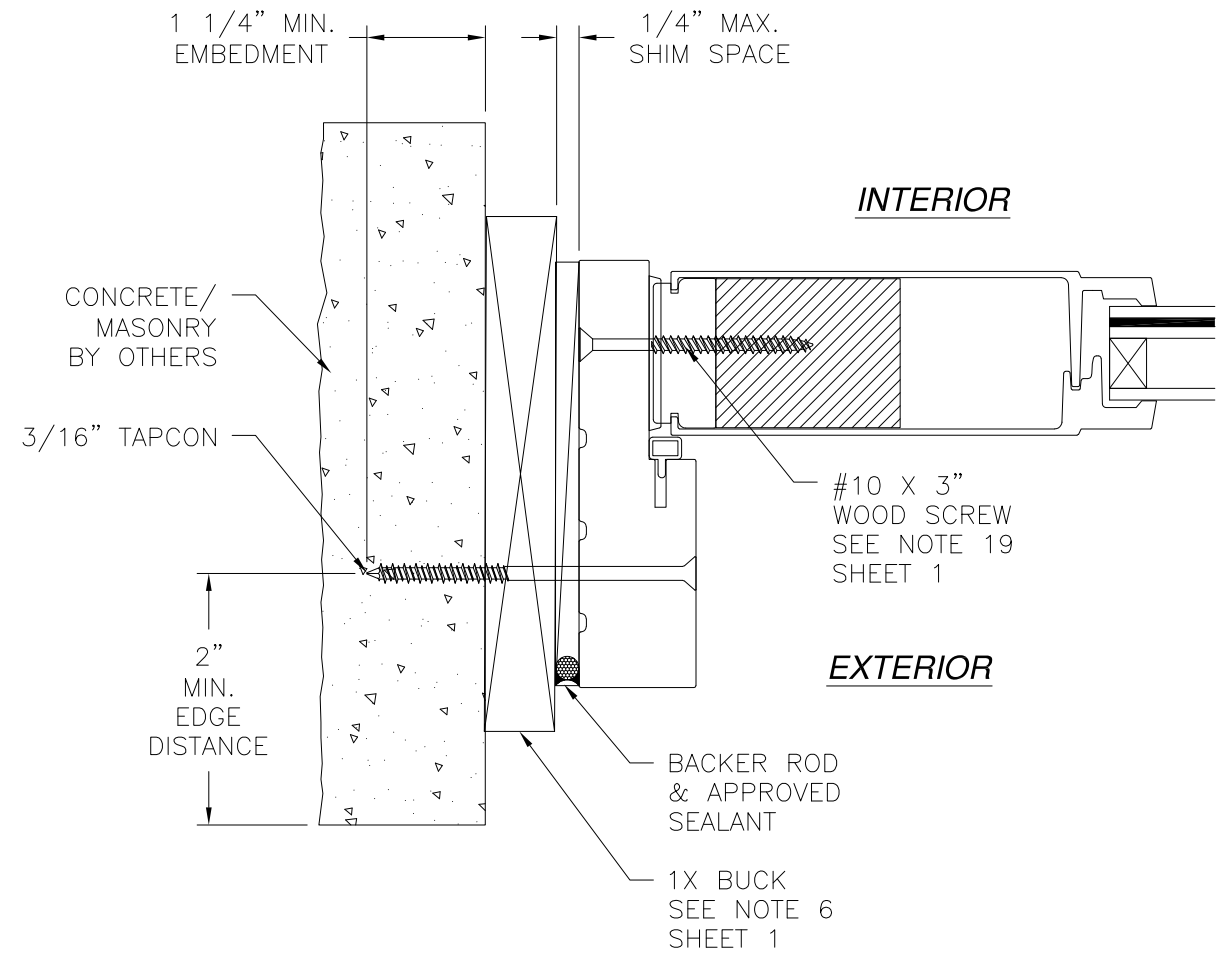

**SIDELITE INSTALLATION DETAIL**  
 CONCRETE/MASONRY W/1X BUCK INSTALLATION

- NOTES:**
1. INTERIOR AND EXTERIOR FINISHES, BY OTHERS, NOT SHOWN FOR CLARITY.
  2. PERIMETER AND JOINT SEALANT BY OTHERS TO BE DESIGNED IN ACCORDANCE WITH ASTM E2112

SIGNED: 03/25/2022

NAN YA PLASTICS CORPORATION U.S.A.  
 8989 NORTH LOOP EAST  
 HOUSTON, TX 77029

SERIES "SLPS" GLAZED FIBERGLASS INSWING SIDE-HINGED DOOR W/SIDELITES - IMPACT  
 SIDELITE INSTALLATION DETAILS

DRAWN: A.R.	DWG NO. 08-03313	REV B
SCALE NTS	DATE 09/27/18	SHEET 13 OF 17

L. ROBERTO LOMAS P.E.  
 400 S. PALM AVE, INDIALANTIC, FL 32903  
 434-688-0609 rllomas@rlomaspe.com



Luis R. Lomas P.E.  
 TX No.: 101889  
 Firm No: F-23130

REVISIONS			
REV	DESCRIPTION	DATE	APPROVED
A	REVISED TO ADD 3/4 LITE PANEL	02/11/2021	R.L.
B	REVISED TO ADD INSTALLATION DETAILS	03/15/2022	R.L.

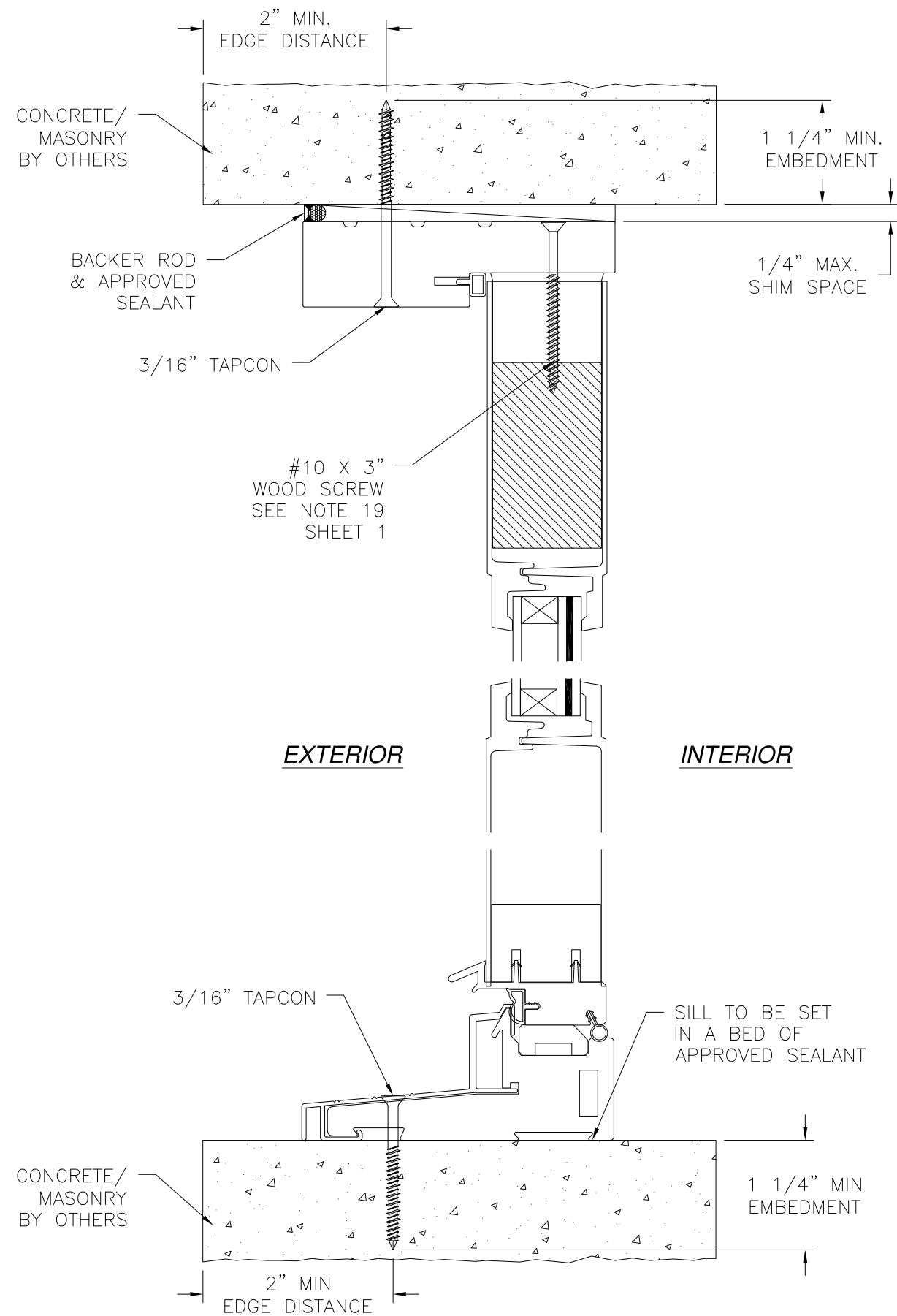

**SIDELITE DOOR INSTALLATION DETAIL**  
CONCRETE/MASONRY INSTALLATION

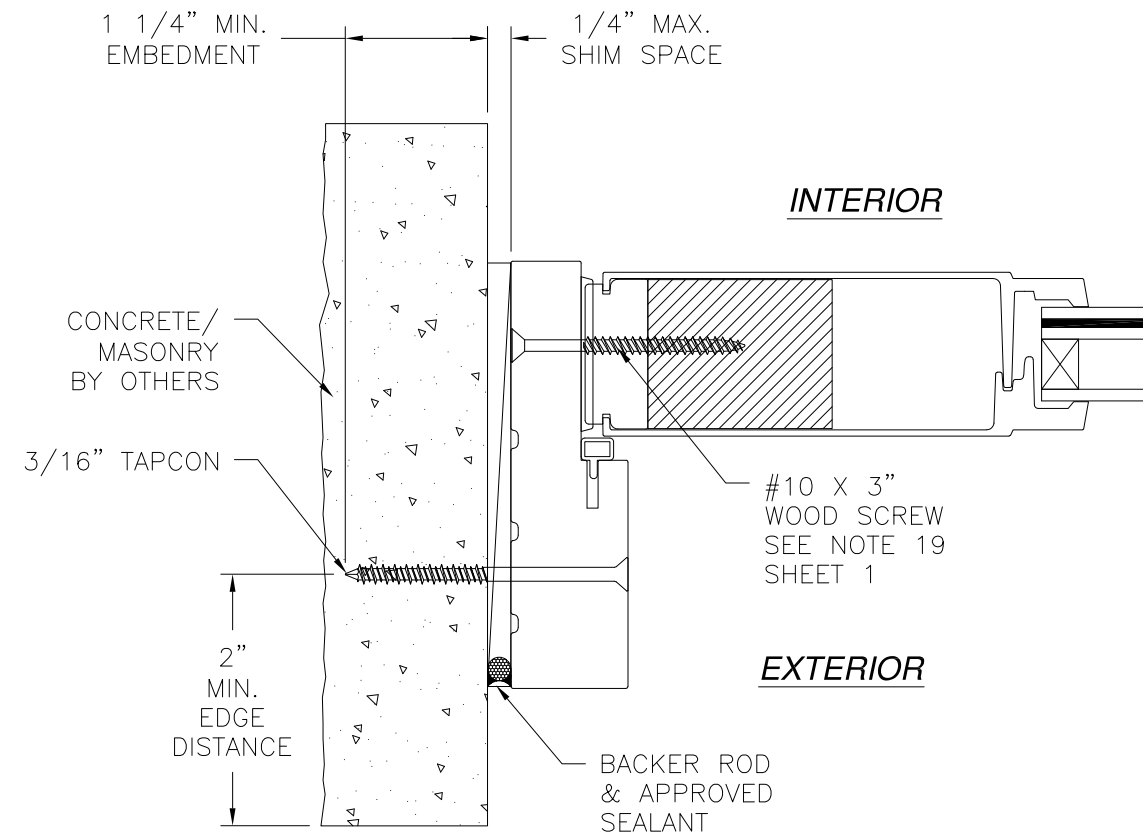

**SIDELITE INSTALLATION DETAIL**  
CONCRETE/MASONRY INSTALLATION

**NOTES:**

1. INTERIOR AND EXTERIOR FINISHES, BY OTHERS, NOT SHOWN FOR CLARITY.
2. PERIMETER AND JOINT SEALANT BY OTHERS TO BE DESIGNED IN ACCORDANCE WITH ASTM E2112

SIGNED: 03/25/2022

NAN YA PLASTICS CORPORATION U.S.A.  
8989 NORTH LOOP EAST  
HOUSTON, TX 77029

SERIES "SLPS" GLAZED FIBERGLASS INSWING  
SIDE-HINGED DOOR W/SIDELITES - IMPACT  
SIDELITE INSTALLATION DETAILS

DRAWN: A.R.	DWG NO. 08-03313	REV B
SCALE NTS	DATE 09/27/18	SHEET 14 OF 17

L. ROBERTO LOMAS P.E.  
400 S. PALM AVE, INDIALANTIC, FL 32903  
434-688-0609 rllomas@rlomaspe.com



Luis R. Lomas P.E.  
TX No.: 101889  
Firm No: F-23130

REVISIONS			
REV	DESCRIPTION	DATE	APPROVED
A	REVISED TO ADD 3/4 LITE PANEL	02/11/2021	R.L.
B	REVISED TO ADD INSTALLATION DETAILS	03/15/2022	R.L.

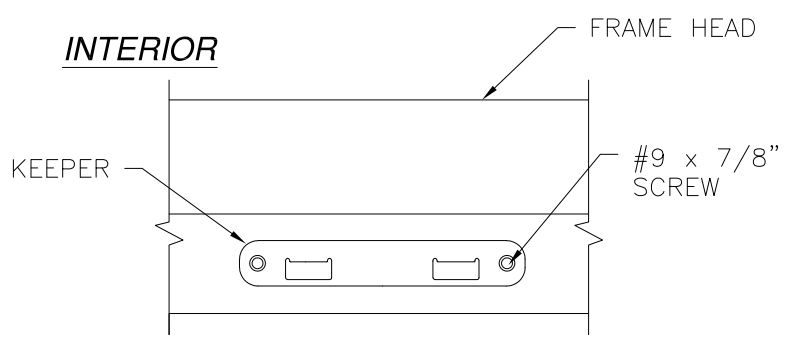

**EXTERIOR**  
**HEAD KEEPER DETAIL**

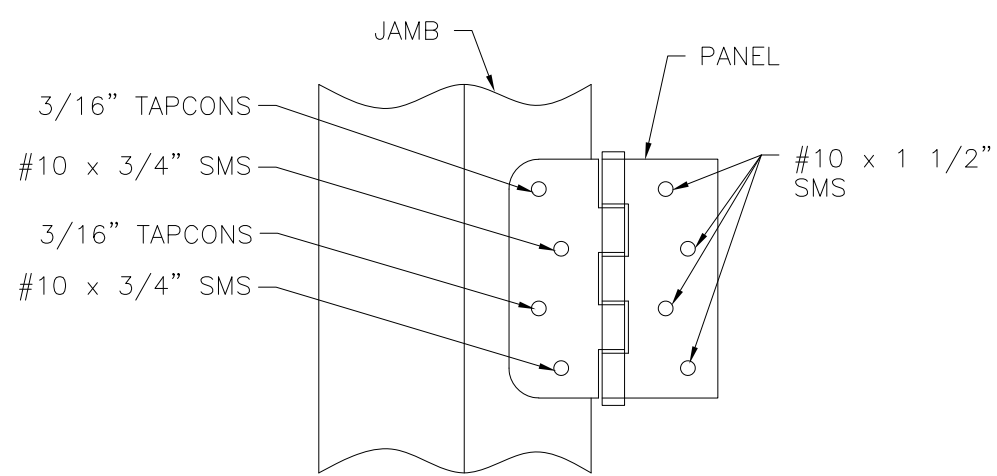

**HINGE INSTALLATION DETAIL**  
**MASONRY/CONCRETE INSTALLATION**

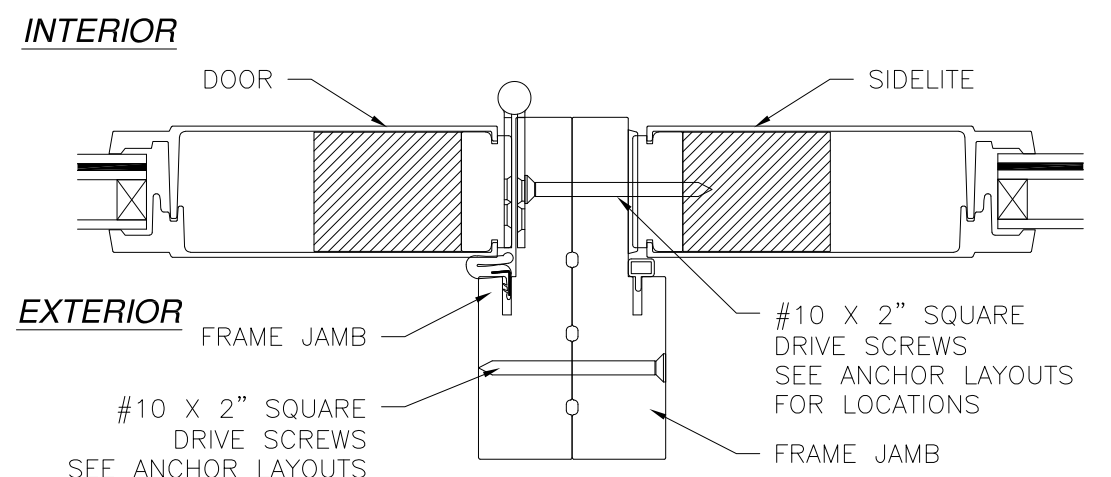

**MULLION DETAIL**  
**DOOR ANCHORS SCREWS**  
**NOT SHOWN FOR CLARITY**

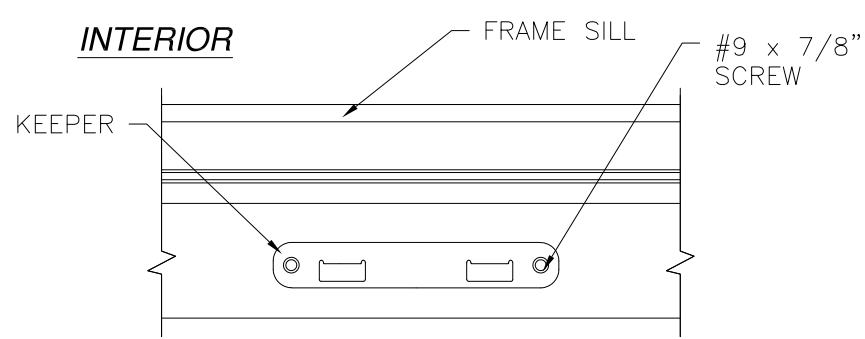

**EXTERIOR**  
**SILL KEEPER DETAIL**

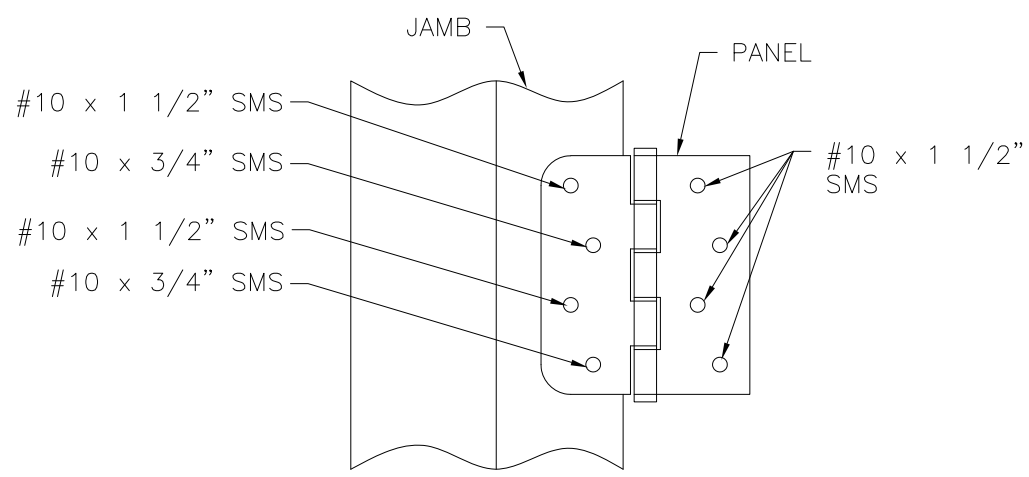

**HINGE INSTALLATION DETAIL**  
**WOOD AND METAL INSTALLATION**

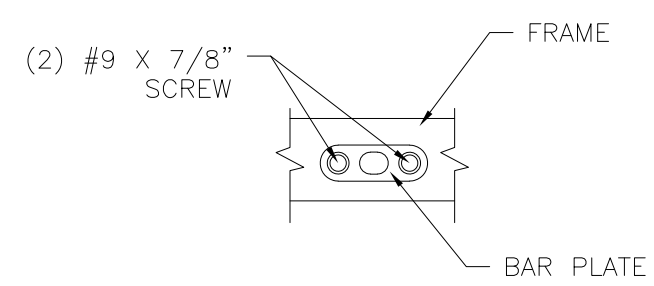

**DRIVE BAR PLATE DETAIL**

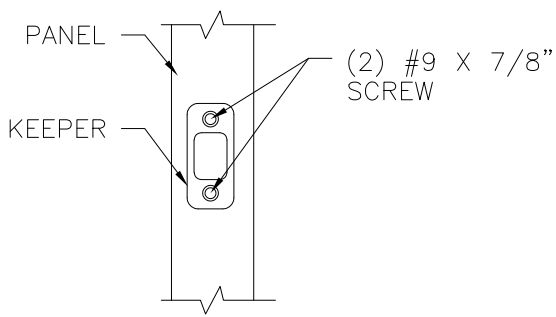

**DEADBOLT KEEPER DETAIL**

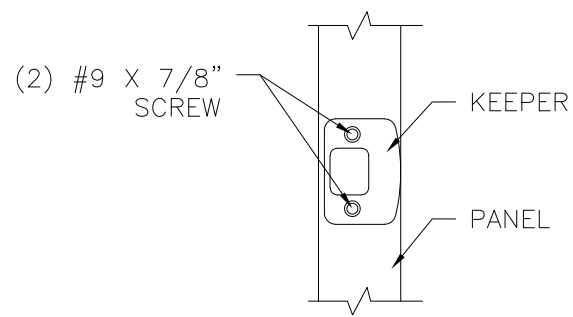

**LATCH KEEPER DETAIL**

SIGNED: 03/25/2022

NAN YA PLASTICS CORPORATION U.S.A.  
 8989 NORTH LOOP EAST  
 HOUSTON, TX 77029

SERIES "SLPS" GLAZED FIBERGLASS INSWING  
 SIDE-HINGED DOOR W/SIDELITES - IMPACT  
 INSTALLATION DETAILS & COMPONENTS

DRAWN: A.R.	DWG NO. 08-03313	REV B
SCALE NTS	DATE 09/27/18	SHEET 15 OF 17

L. ROBERTO LOMAS P.E.  
 400 S. PALM AVE, INDIALANTIC, FL 32903  
 434-688-0609 rllomas@rlomaspe.com



Luis R. Lomas P.E.  
 TX No.: 101889  
 Firm No: F-23130

REVISIONS			
REV	DESCRIPTION	DATE	APPROVED
A	REVISED TO ADD 3/4 LITE PANEL	02/11/2021	R.L.
B	REVISED TO ADD INSTALLATION DETAILS	03/15/2022	R.L.

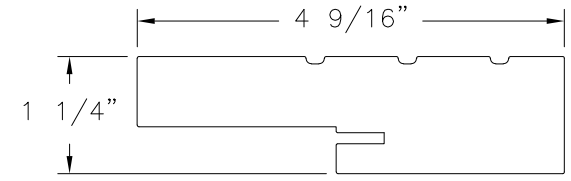

**HEAD FRAME & JAMB**  
FOAM PVC CO-EX

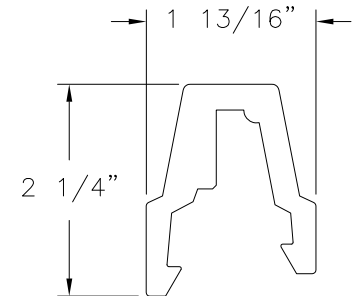

**MULLION COVER (B)**  
FOAM PVC

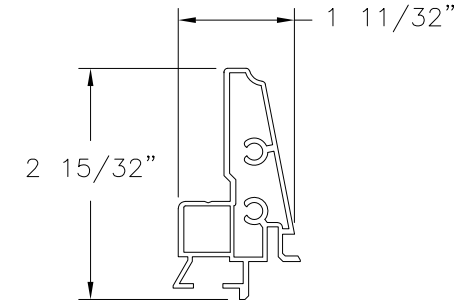

**REINFORCEMENT (B)**  
ALUMINUM

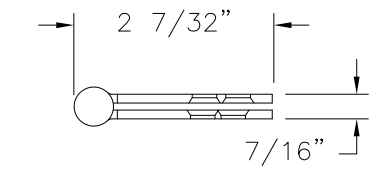

**4" X 4" DOOR HINGE**  
STEEL

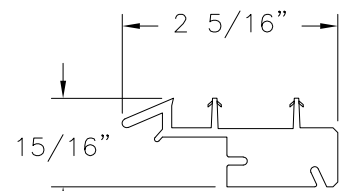

**DOOR BOTTOM-A**  
PVC CO-EX

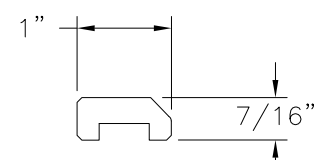

**STATIONARY BASE**  
FOAM PVC

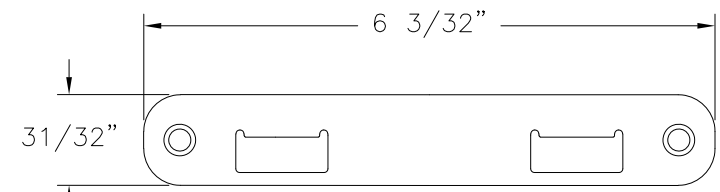

**TOP/BOTTOM BAR KEEPER**  
STAINLESS STEEL (SS92P)  
BY JAM YUAN ENTERPRISES CO., LTD

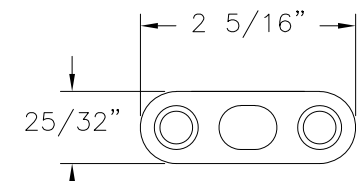

**DRIVE BAR PLATE**  
STAINLESS STEEL  
BY JAM YUAN ENTERPRISES CO., LTD.

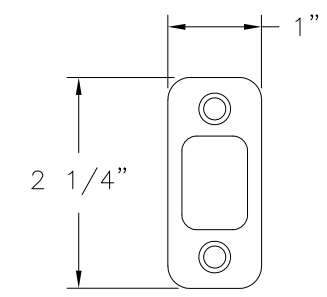

**DEADBOLT KEEPER**  
STAINLESS STEEL  
BY JAM YUAN ENTERPRISES CO., LTD

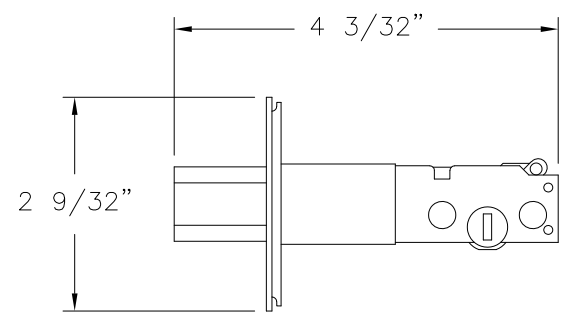

**DOOR DEADBOLT**  
STEEL (SS92Y)  
BY JAM YUAN ENTERPRISES CO., LTD

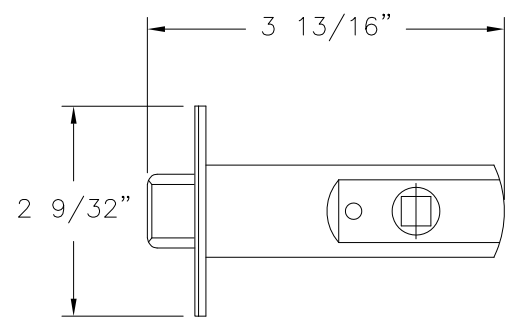

**DOOR LATCH**  
STEEL (SS92Y)  
BY JAM YUAN ENTERPRISES CO., LTD

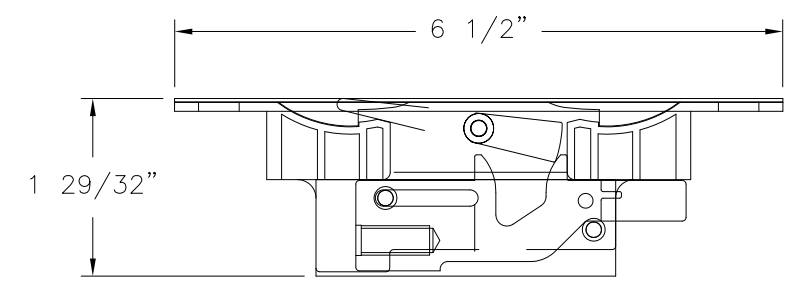

**FLUSH BOLT MECHANISM**  
DIE CAST, STEEL, POM (SS93X)  
BY JAM YUAN ENTERPRISES CO., LTD

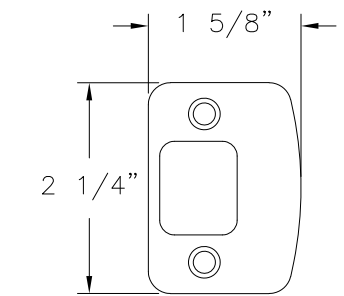

**LATCH KEEPER**  
STAINLESS STEEL  
BY JAM YUAN ENTERPRISES CO., LTD

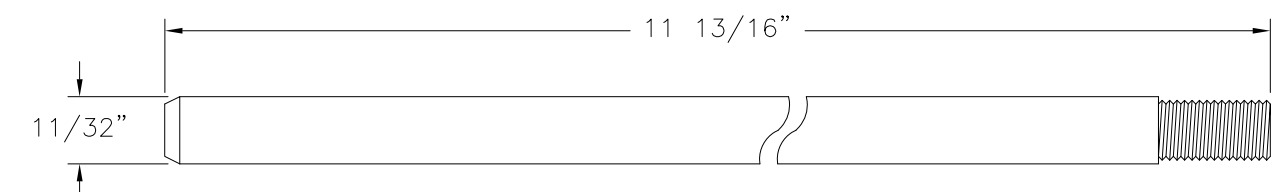

**FLUSH BOLT BAR**  
STAINLESS STEEL (SS93B)  
BY JAM YUAN ENTERPRISES CO., LTD

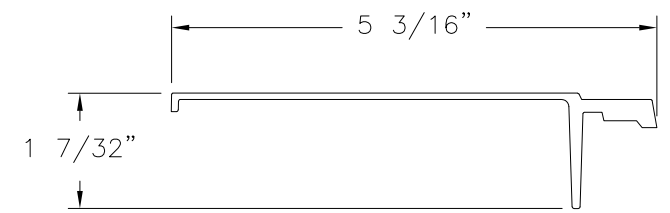

**SHEET MOLDING COMPOUND SKIN-1**  
FIBERGLASS

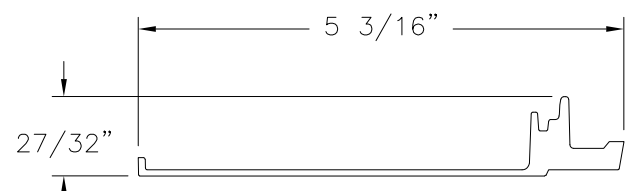

**SHEET MOLDING COMPOUND SKIN-2**  
FIBERGLASS

SIGNED: 03/25/2022

NAN YA PLASTICS CORPORATION U.S.A.  
8989 NORTH LOOP EAST  
HOUSTON, TX 77029

SERIES "SLPS" GLAZED FIBERGLASS INSWING  
SIDE-HINGED DOOR W/SIDELITES - IMPACT  
COMPONENTS

DRAWN: A.R.	DWG NO. 08-03313	REV B
SCALE NTS	DATE 09/27/18	SHEET 16 OF 17

L. ROBERTO LOMAS P.E.  
400 S. PALM AVE, INDIALANTIC, FL 32903  
434-688-0609 rllomas@rlomaspe.com



Luis R. Lomas P.E.  
TX No.: 101889  
Firm No: F-23130



REVISIONS			
REV	DESCRIPTION	DATE	APPROVED
A	REVISED TO ADD 3/4 LITE PANEL	02/11/2021	R.L.
B	REVISED TO ADD INSTALLATION DETAILS	03/15/2022	R.L.

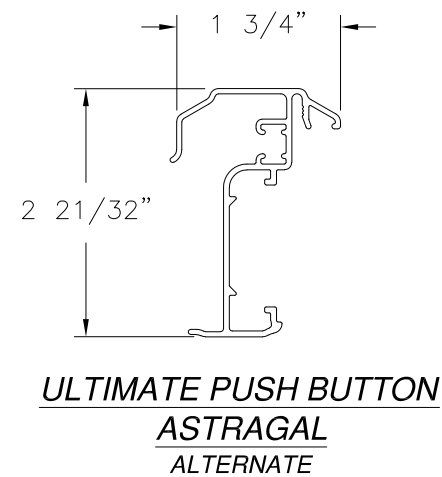
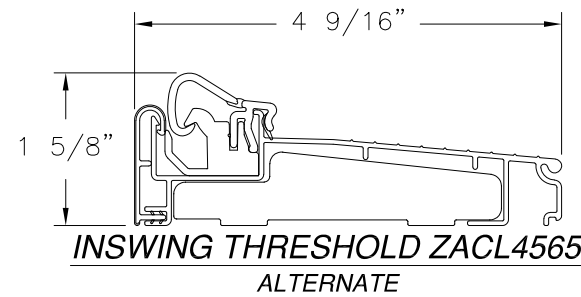
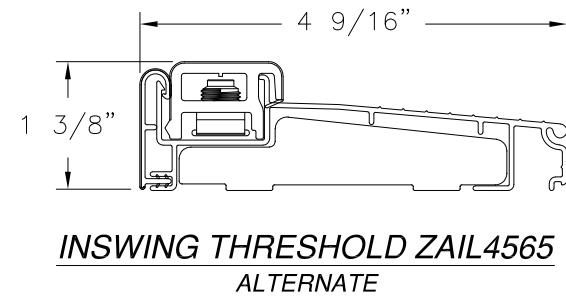
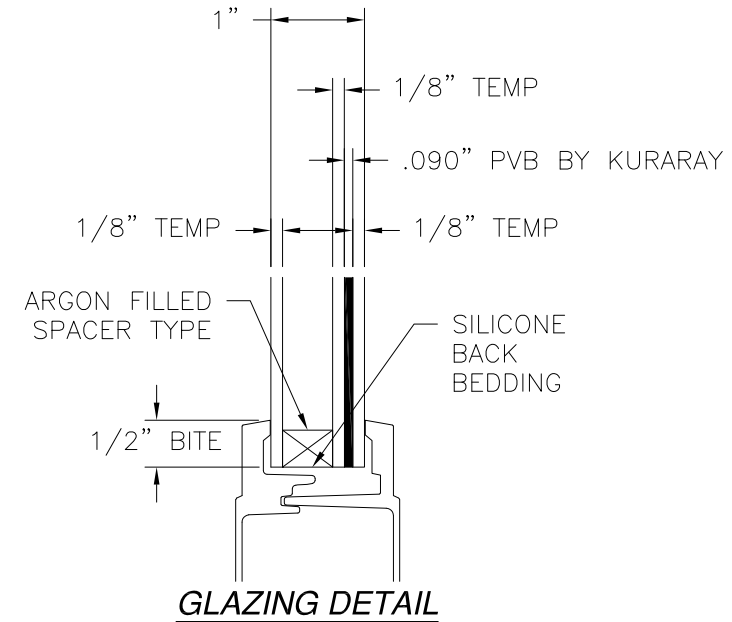
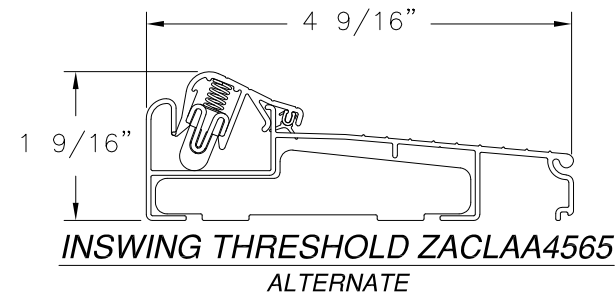
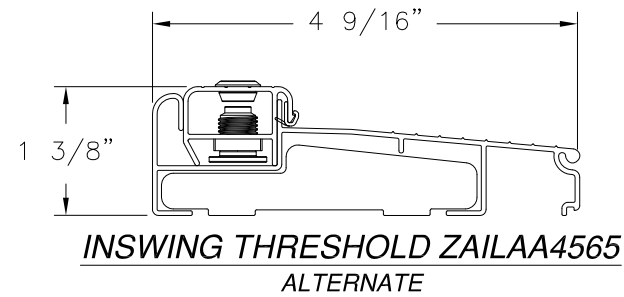
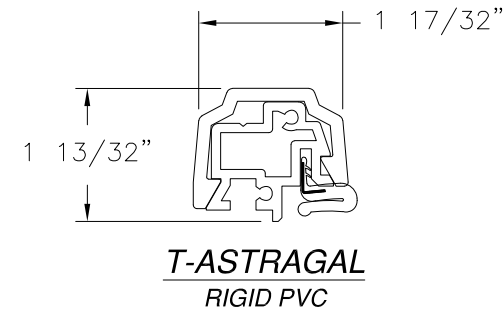
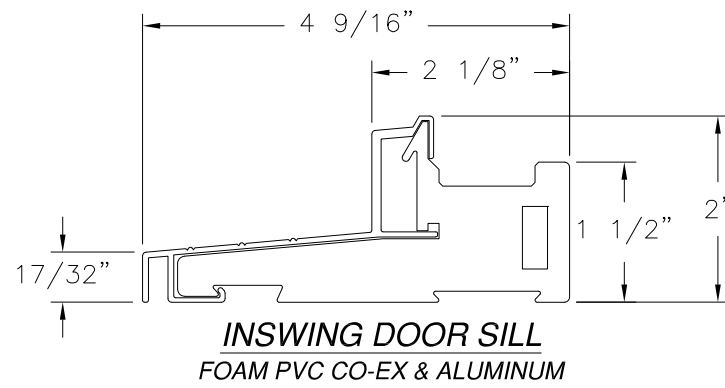

SIGNED: 03/25/2022

NAN YA PLASTICS CORPORATION U.S.A.  
8989 NORTH LOOP EAST  
HOUSTON, TX 77029

SERIES "SLPS" GLAZED FIBERGLASS INSWING  
SIDE-HINGED DOOR W/SIDELITES - IMPACT  
COMPONENTS & GLAZING DETAILS

DRAWN: A.R.	DWG NO. 08-03313	REV B
SCALE NTS	DATE 09/27/18	SHEET 17 OF 17

L. ROBERTO LOMAS P.E.  
400 S. PALM AVE, INDIALANTIC, FL 32903  
434-688-0609 rllomas@rlomaspe.com



Luis R. Lomas P.E.  
TX No.: 101889  
Firm No: F-23130