

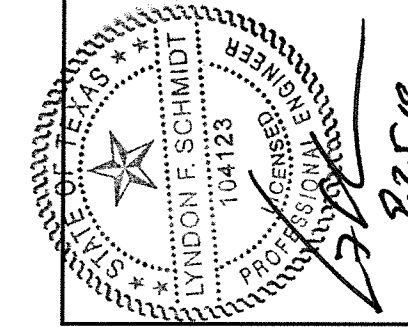

"FusionFrame"



Glazed Fiberglass Door

"NON-IMPACT"
INSWING / OUTSWING

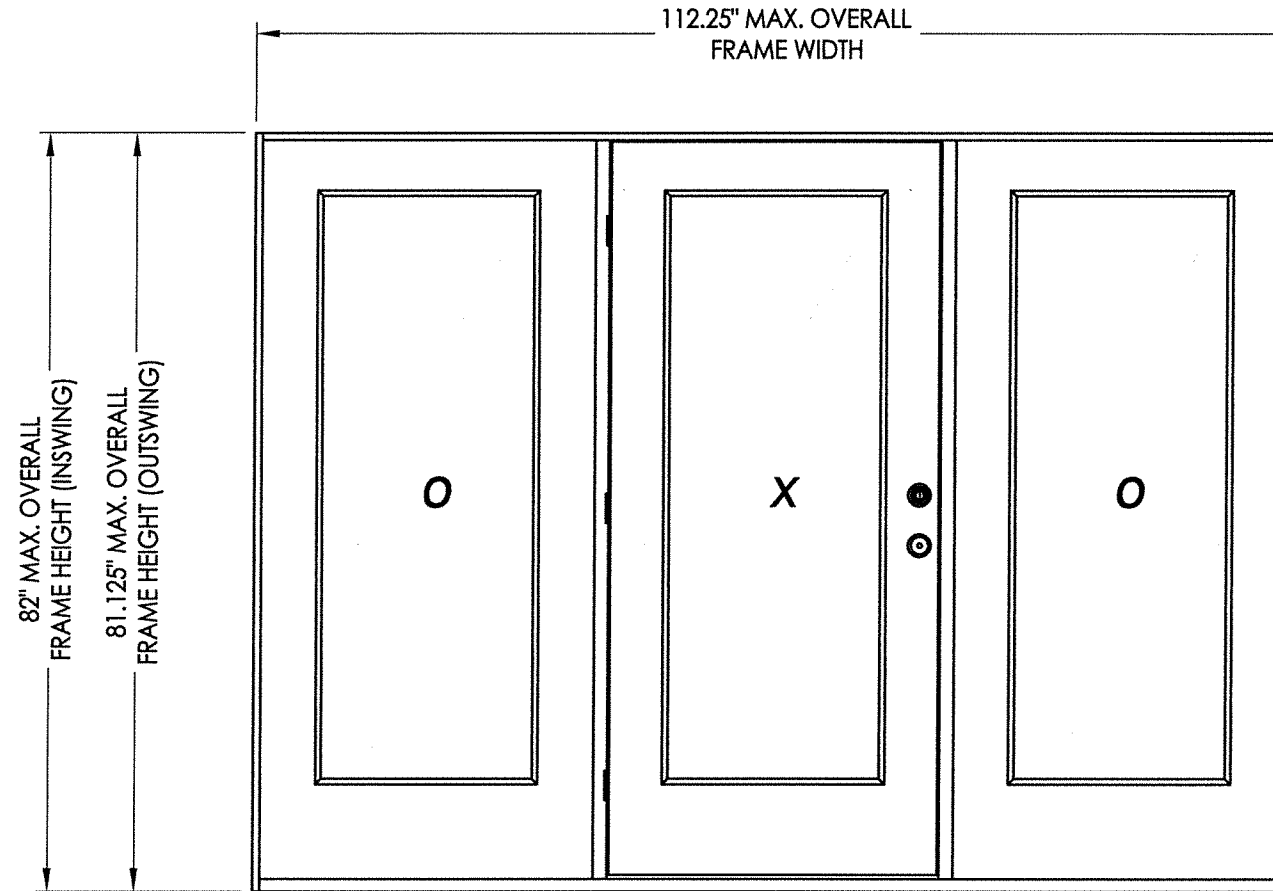

EVALUATED FOR USE IN THE STATE OF TEXAS

The Glazed Fiberglass Door system described herein complies with the 2018 International Residential Code (IRC), Sections R301 & R609 and the 2018 International Building Code (IBC), Sections 1404.13, 1609, 1709.5, 2403 and 2404 subject to the following conditions:

1. Anchors shall be as listed and spaced as shown in the details. Anchor embedment to base material shall be beyond wall dressing or stucco.
2. When used in areas requiring wind-borne debris protection this product is required to be protected with an impact resistant covering that complies with Section R301.2.1.2 of the IRC and Section 1609.2 of the IBC.
3. Allowable design pressure requirements must be equal to or less than the design pressure rating shown in the design pressure chart, sheet 1 of this drawing.
4. Conditions not covered by this drawing are subject to further engineering analysis.

TABLE OF CONTENTS	
SHEET#	DESCRIPTION
1	Typical elevations, design pressures & general notes
2	Door panel details (lip lite insert glazing)
3	Slidelite panel details (lip lite insert glazing)
4	Horizontal cross sections
5	Vertical cross sections
6	Vertical cross sections
7	Frame anchoring

CONFIG.	MODEL	DESIGN PRESSURE (PSF)	
		POSITIVE	NEGATIVE
OXO	INSWING	+50.0	-50.0
OXO	OUTSWING	+40.0	-40.0

Documents Prepared By: Lyndon F. Schmidt, P.E.
TEXAS P.E. #104123

RW BUILDING CONSULTANTS, INC.
P.O. Box 230 Valrico FL 33595
Phone No.: 813.659.9197
TEXAS BOARD OF PROFESSIONAL ENGINEERS
CERTIFICATE OF REGISTRATION # F-11852

PRODUCT: ENDURA
PART OR ASSEMBLY: TYPICAL ELEVATION, DESIGN PRESSURES & GENERAL NOTES

NO.	DATE	REVISIONS
1	9/23/19	ADD "FusionFrame" OPTION & UPDATE TO 2018 IBC/IRC CODE

DATE: 11/8/18
SCALE: N.T.S.
DWG. BY: JK
CHK. BY: LFS
DRAWING NO.: TX-4905
SHEET 1 OF 7

R:\Clients\Endura PERMANENT\B - Texas Dept of Ins\TDI - DR-1018 Flush GLZ Masonite FG door (4904-4909)\C - Drawings\TX-4905-08.dwg, 2.3

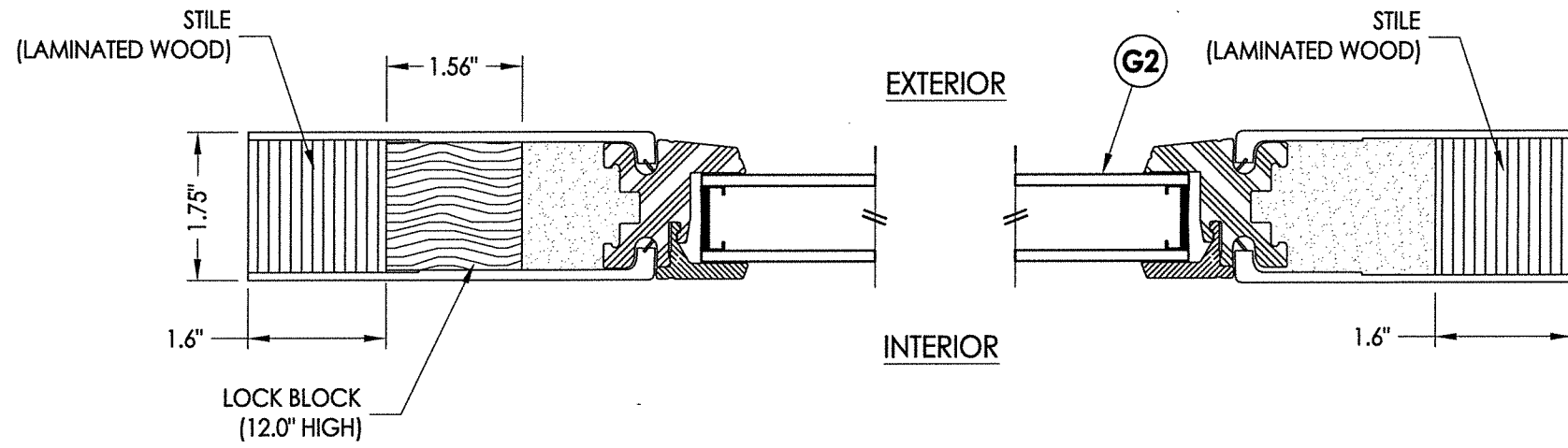

1
2 HORIZONTAL CROSS SECTION

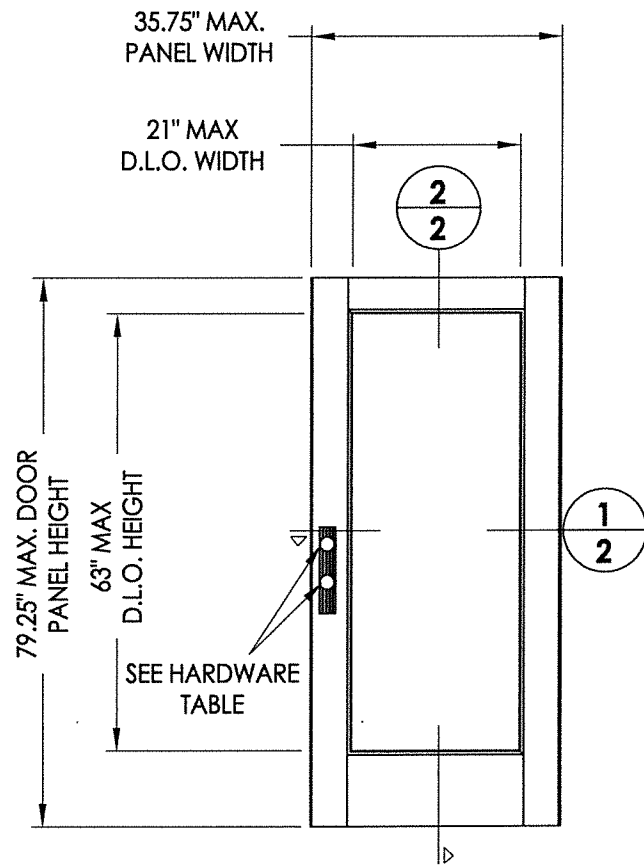

MASONITE
Flush glazed
(fiberglass)

HARDWARE TABLE	
MANUFACTURER	MODEL
KWIKSET	LATCH: KWIKSET SIGNATURE SERIES (991) DEADBOLT: KWIKSET SIGNATURE SERIES (980/985)

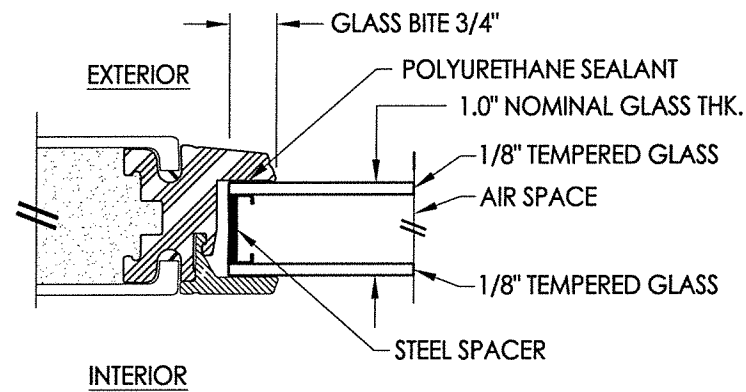

G2 GLAZING DETAIL
Flush Glazing

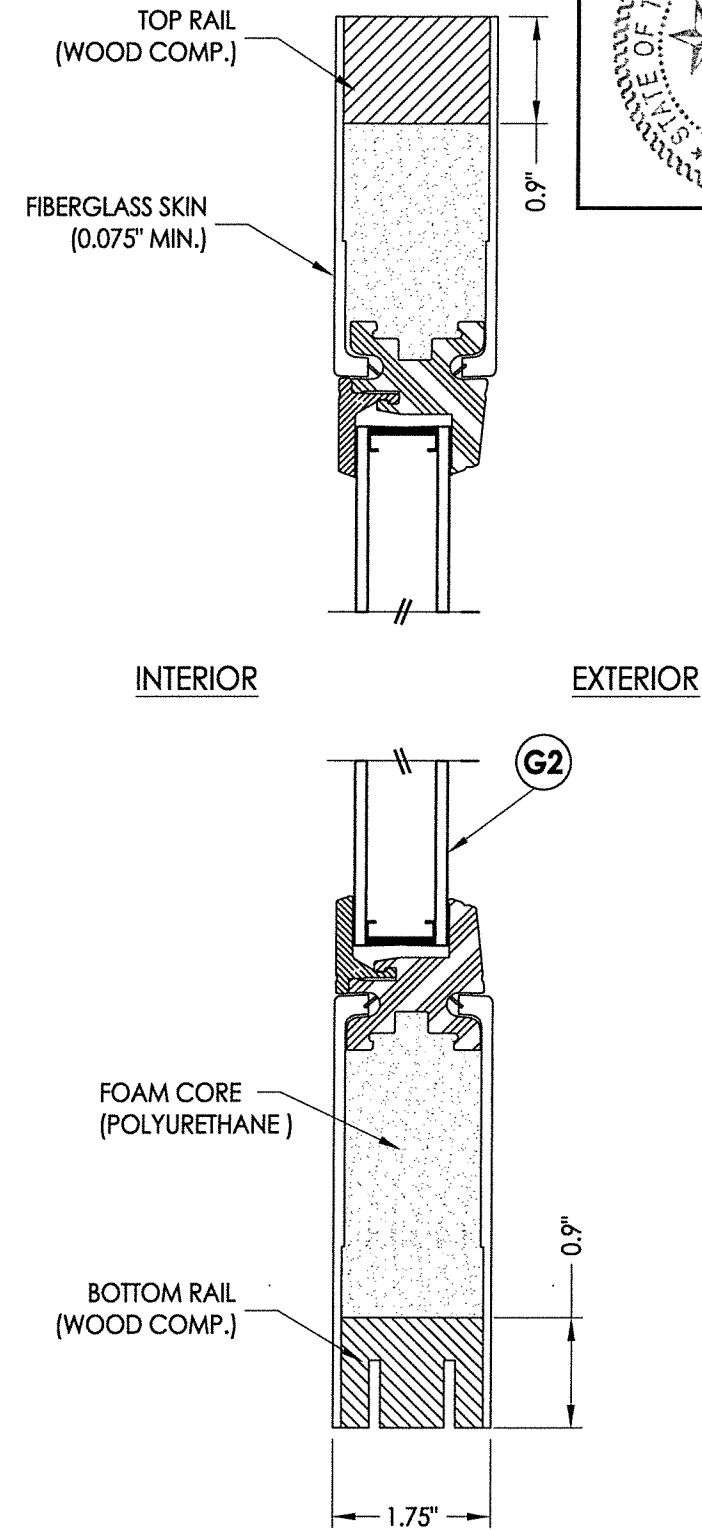

2
2 VERTICAL CROSS SECTION

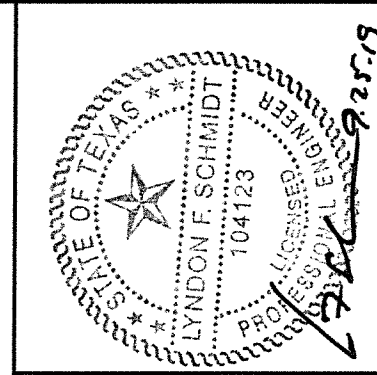

Documents Prepared By: Lyndon F. Schmidt, P.E.
TEXAS P.E. #104123

RW BUILDING CONSULTANTS, INC.
P.O. Box 230 Valrico FL 33595
Phone No.: 813.659.9197
TEXAS BOARD OF PROFESSIONAL ENGINEERS
CERTIFICATE OF REGISTRATION # F-11852

PRODUCT:	ENDURA	
PART OR ASSEMBLY:	DOOR PANEL DETAILS (FLUSH GLAZING)	
NO.	DATE	BY
1	9/23/19	LFS
ADD "FusionFrame" OPTION & UPDATE TO 2018 IBC/IRC CODE		
REVISIONS		
DATE:	11/8/18	
SCALE:	N.T.S.	
DWG. BY:	JK	
CHK. BY:	LFS	
DRAWING NO.:	TX-4905	
SHEET	2	OF 7

© 2018 R.W. BUILDING CONSULTANTS INC.

R:\Clients\Endura PERMANENT\B - Texas Dept of Ins\TDI - DR-1018 Flush GLZ Masonite FG door (4904-4909)\C - Drawings\TX-4905-08.dwg, 3.3

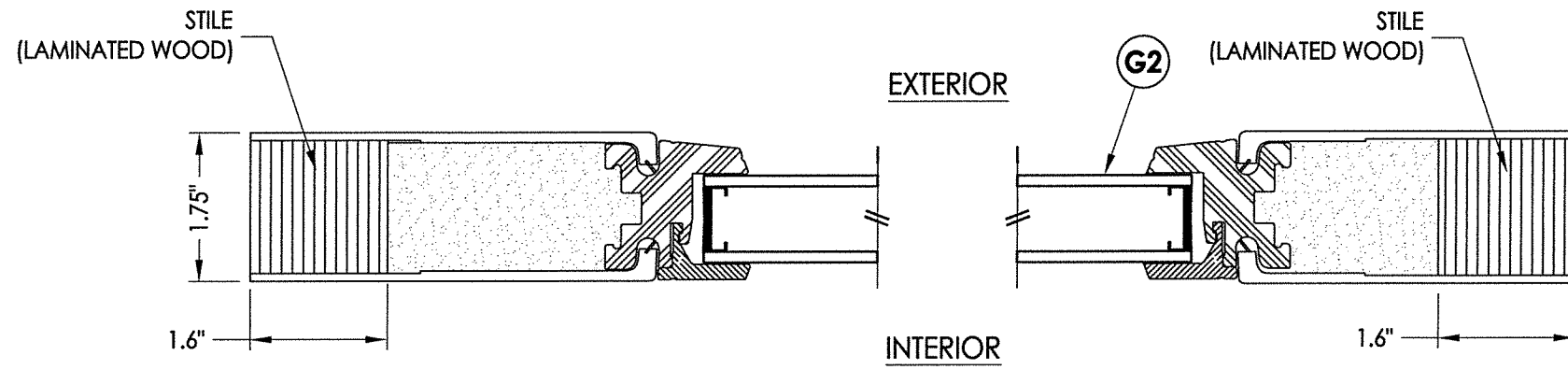

1
3 HORIZONTAL CROSS SECTION

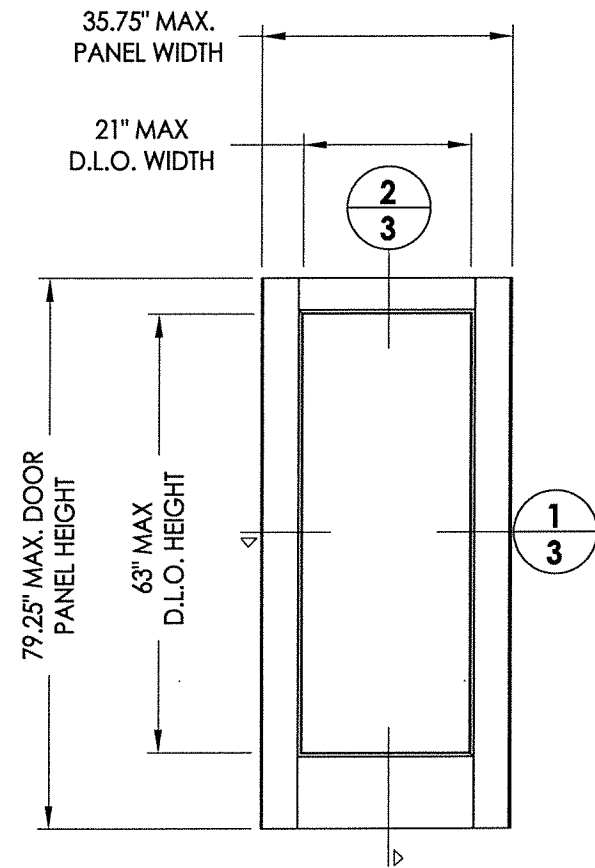

MASONITE
Flush glazed
(fiberglass)

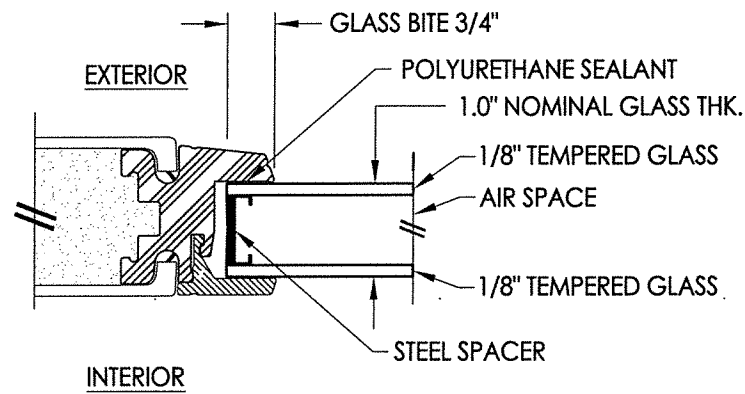

G2 GLAZING DETAIL
Flush Glazing

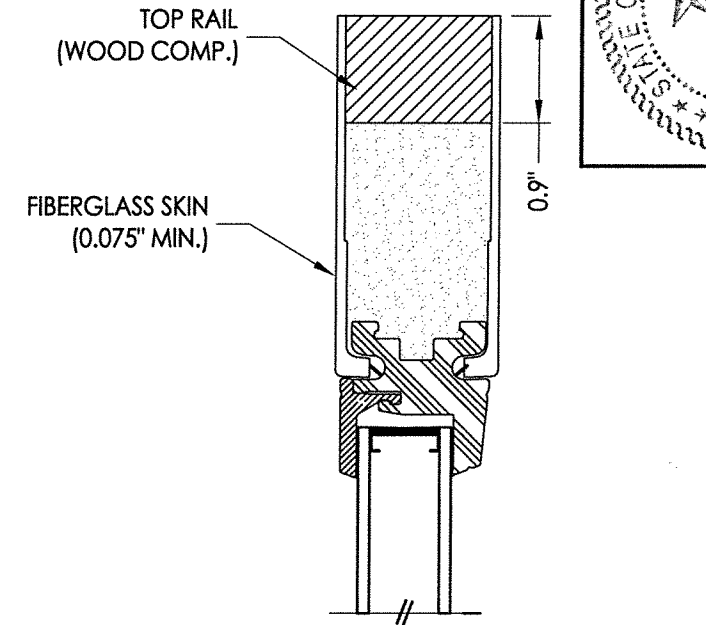

2
3 VERTICAL CROSS SECTION

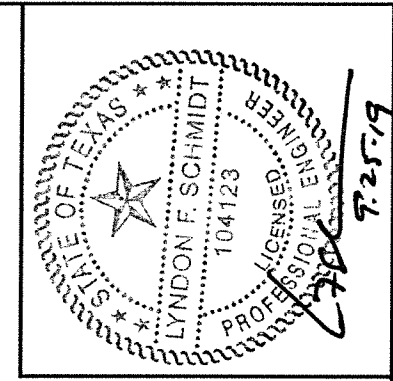
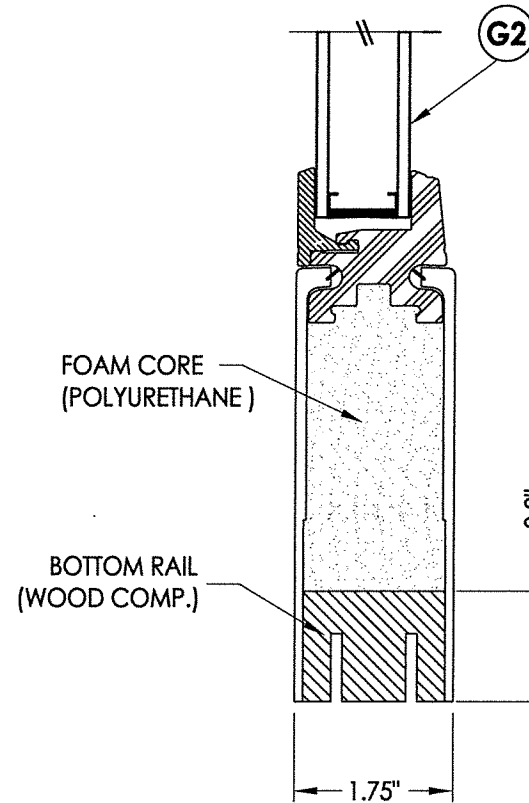

Documents Prepared By: Lyndon F. Schmidt, P.E.
TEXAS P.E. #104123

RW BUILDING CONSULTANTS, INC.
P.O. Box 230 Valrico FL, 33595
Phone No.: 813.659.9197
TEXAS BOARD OF PROFESSIONAL ENGINEERS
CERTIFICATE OF REGISTRATION # F-11852

PRODUCT: ENDURA
PART OR ASSEMBLY: SIDELITE PANEL DETAILS (FLUSH GLAZING)

REVISIONS	
NO.	DATE
1	9/23/19
ADD "FusionFrame" OPTION & UPDATE TO 2018 IBC/IRC CODE	
LFS	BY

DATE: 11/8/18
SCALE: N.T.S.
DWG. BY: JK
CHK. BY: LFS
DRAWING NO.: TX-4905
SHEET 3 OF 7

R:\Clients\Endura PERMANENT\B - Texas Dept of Ins\TDI - DR-1018 Flush GLZ Masonite FG door (4904-4909)C - Drawings\TX-4905-08.dwg, 4.3

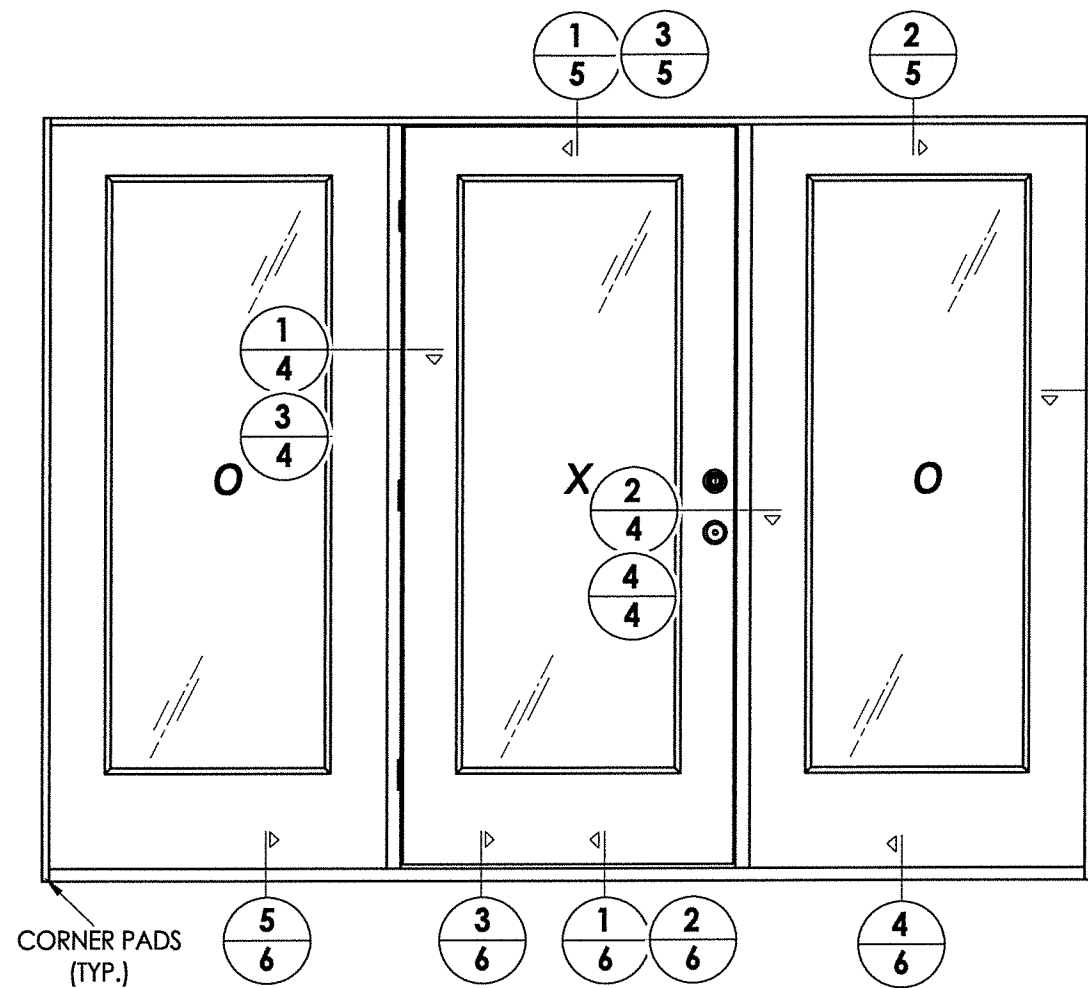

CORNER PADS (TYP.)

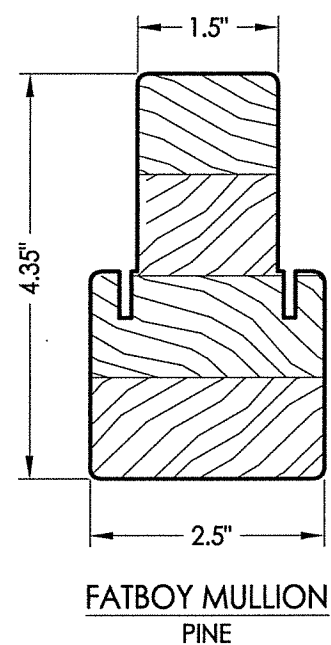

FATBOY MULLION PINE

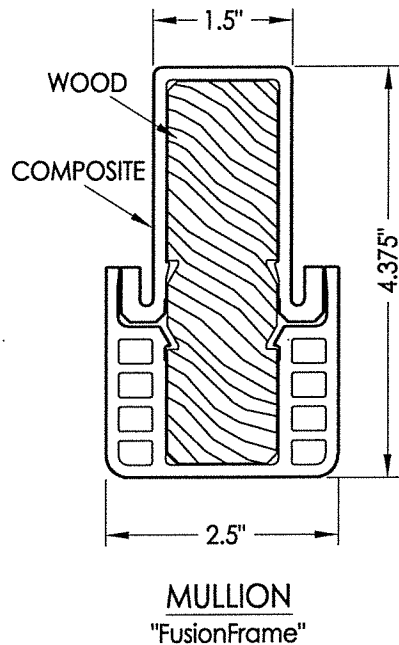

MULLION "FusionFrame"

- NOTES:
1. Spacing for sidelite screws: 6.5", 38.5" and 69" from head to sill (3 total).
 2. Spacing for mullion screws: 6" from each end plus 3 more equally spaced (5 total).

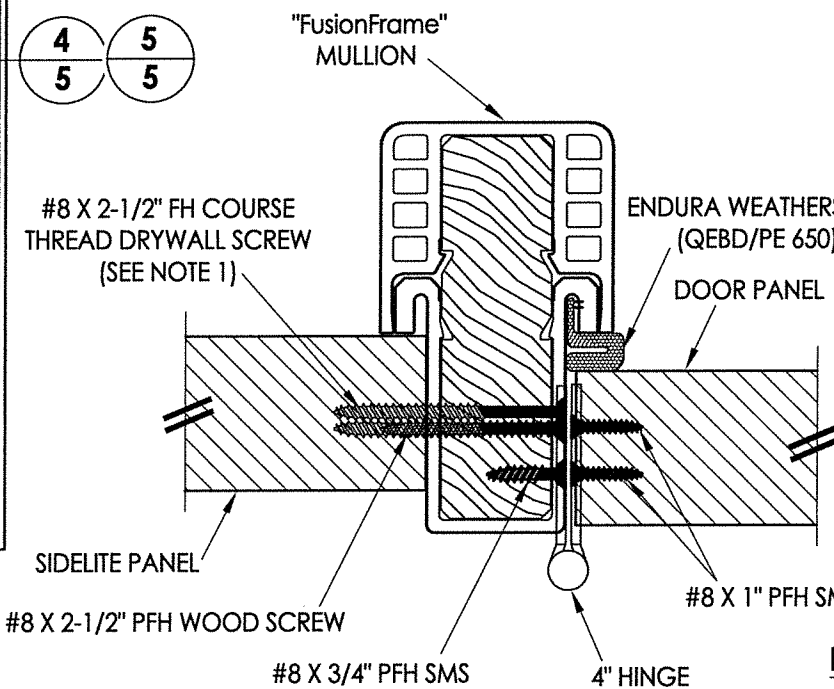

3 HORIZONTAL CROSS SECTION
4 Outswing shown - Inswing also approved

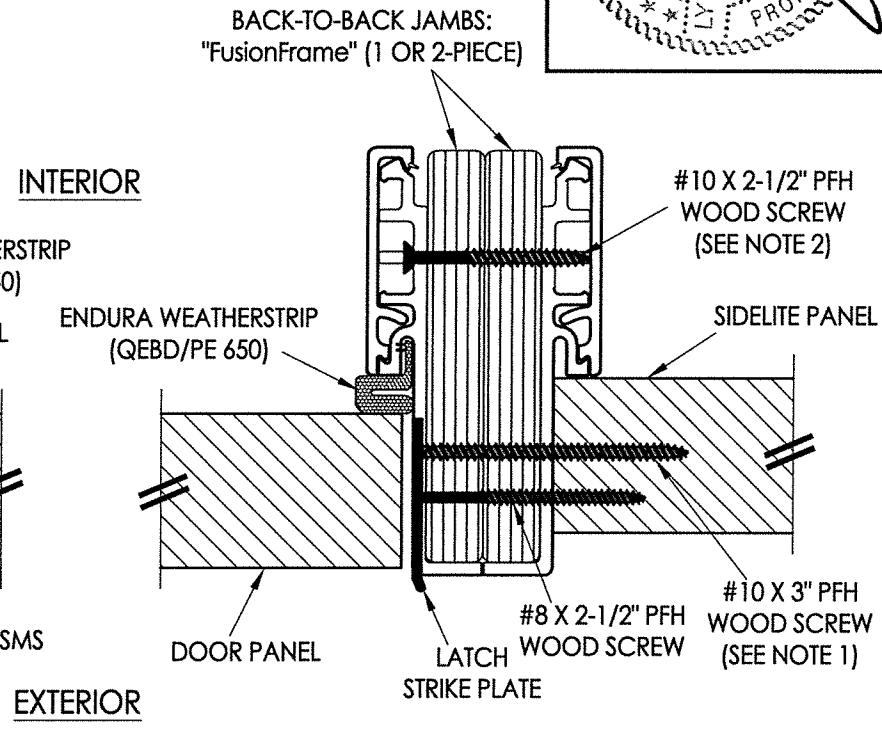

4 HORIZONTAL CROSS SECTION
4 Outswing shown - Inswing also approved

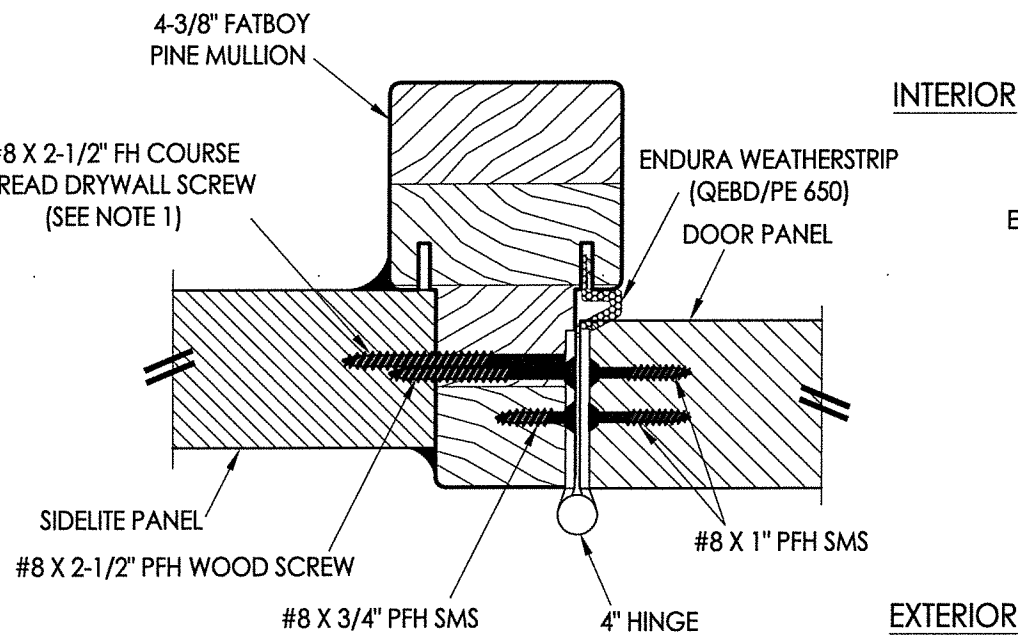

1 HORIZONTAL CROSS SECTION
4 Outswing shown - Inswing also approved

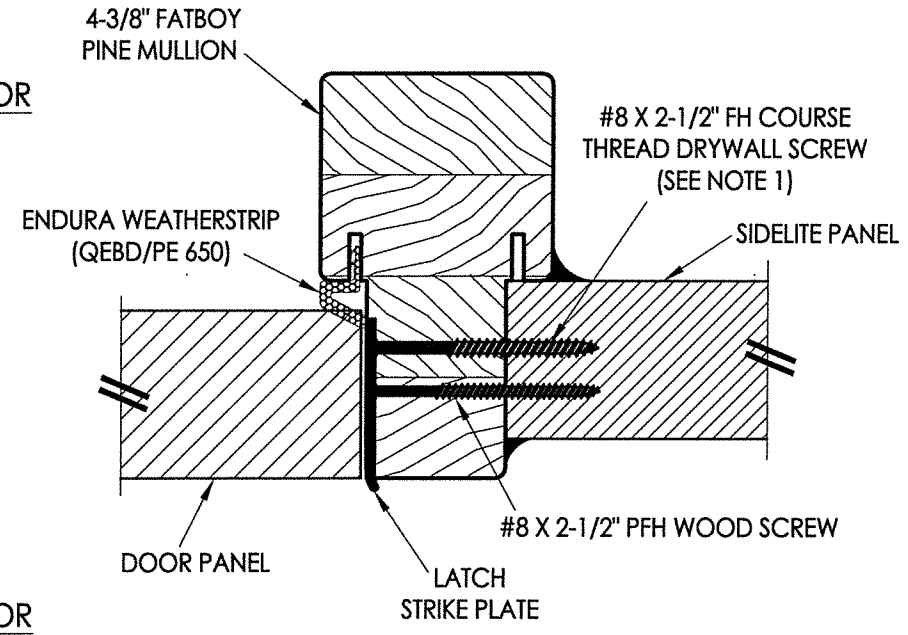

2 HORIZONTAL CROSS SECTION
4 Outswing shown - Inswing also approved

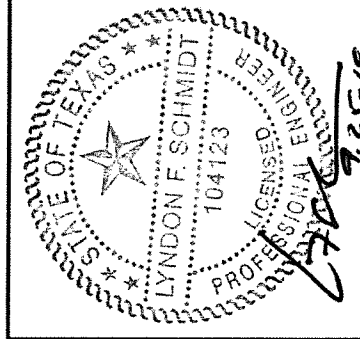

Documents Prepared By: Lyndon F. Schmidt, P.E.
TEXAS P.E. #104123

RW BUILDING CONSULTANTS, INC.
P.O. Box 230 Vairco FL 33595
Phone No.: 813.659.9197
TEXAS BOARD OF PROFESSIONAL ENGINEERS
CERTIFICATE OF REGISTRATION # F-11852

PRODUCT:	ENDURA
PART OR ASSEMBLY:	FIBERGLASS DOOR
BY:	LFS
DATE:	NO. DATE
REVISIONS	

DATE:	11/8/18
SCALE:	N.T.S.
DWG. BY:	JK
CHK. BY:	LFS
DRAWING NO.:	TX-4905
SHEET	4 OF 7

© 2018 R.W. BUILDING CONSULTANTS INC.

R:\Clients\Endura PERMANENT\B - Texas Dept of Ins\TDI - DR-1018 Flush GLZ Masonite FG door (4904-4909)C - Drawings\TX-4905-08.dwg, 5.3

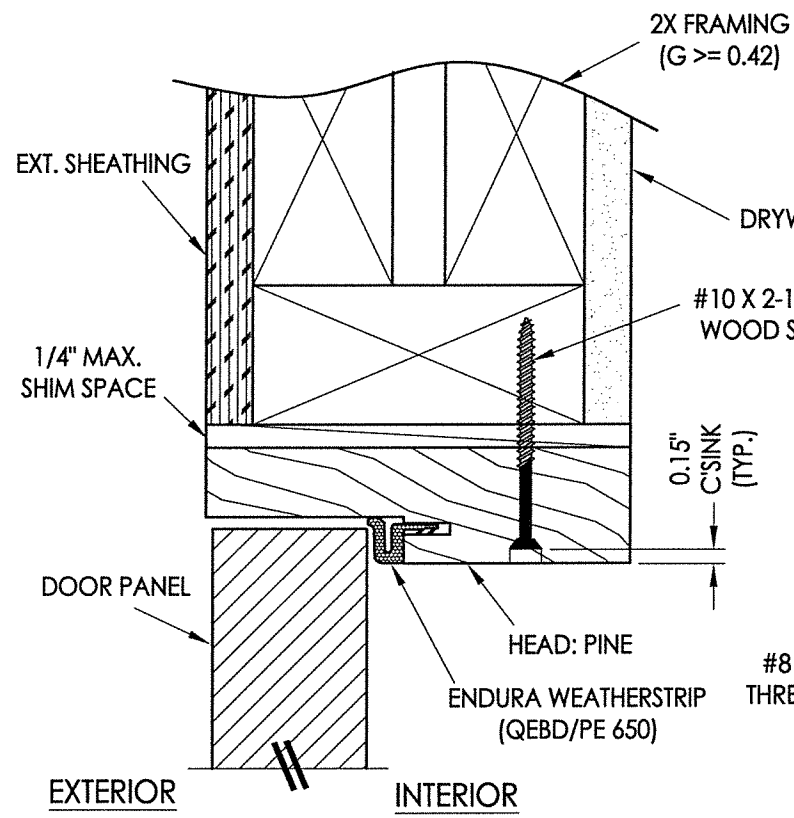

1 VERTICAL CROSS SECTION
5 Outswing shown - inswing also approved

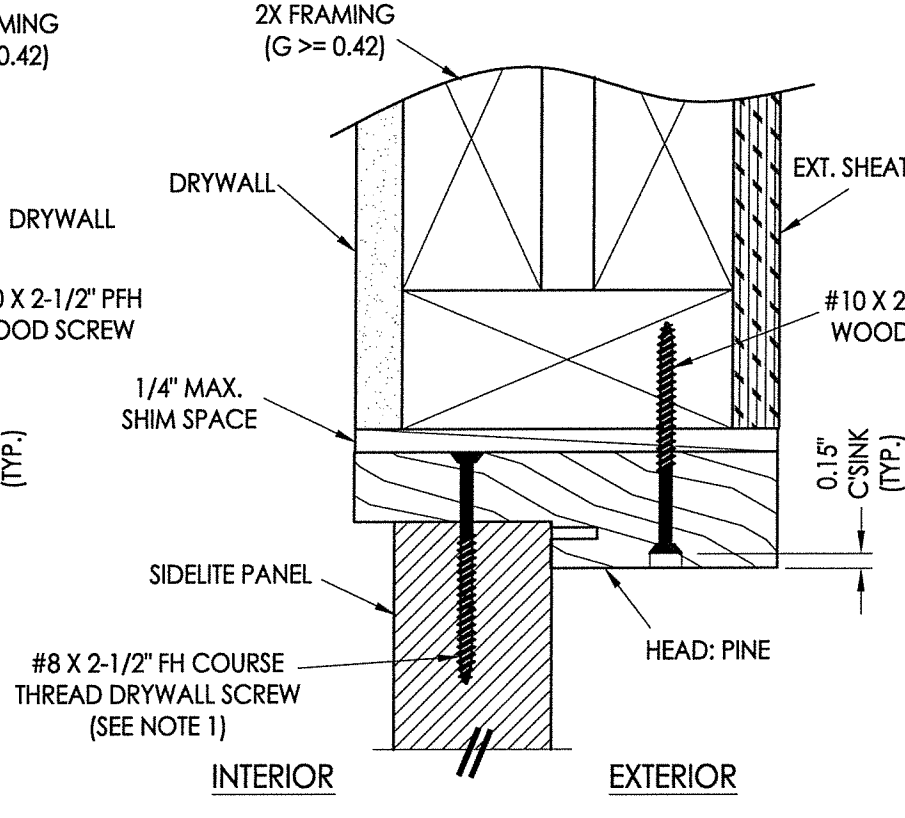

2 VERTICAL CROSS SECTION
5 Inswing shown - Outswing also approved

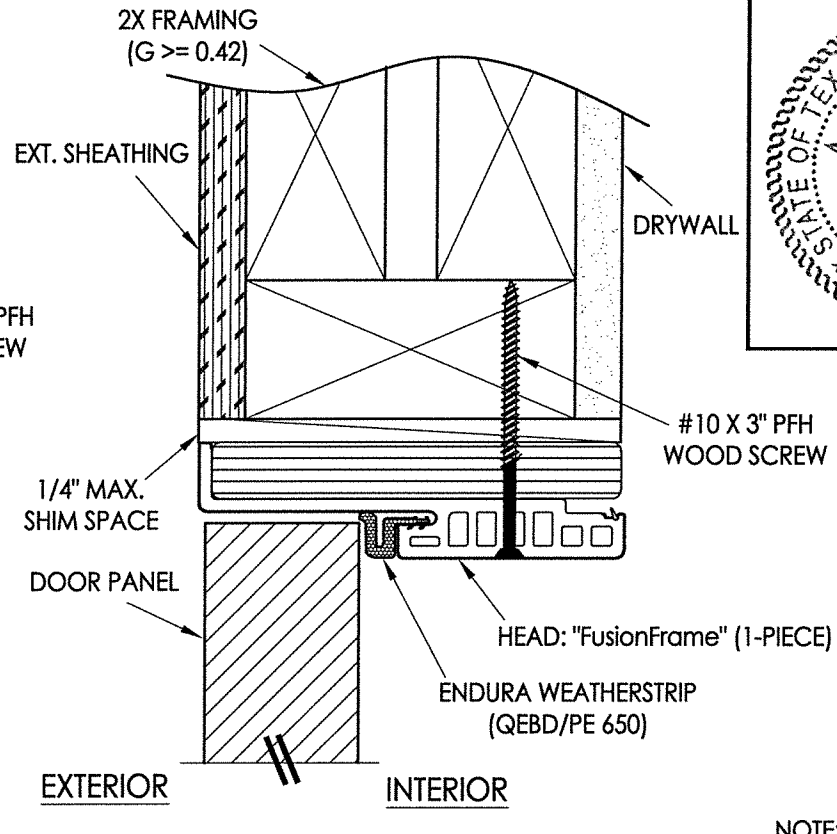

3 VERTICAL CROSS SECTION
5 Outswing shown - inswing also approved

NOTE:
 1. Spacing for sidelite screws:
 6" from each end (2 total).

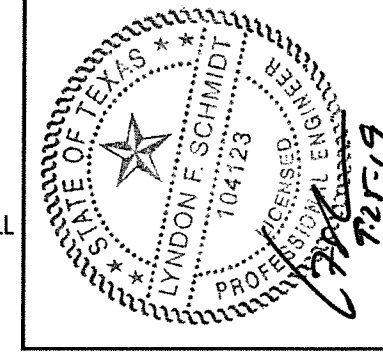

Documents Prepared By: Lyndon F. Schmidt, P.E.
 TEXAS P.E. #104123
RW BUILDING CONSULTANTS, INC.
 P.O. Box 230 Valrico FL 33595
 Phone No.: 813.659.9197
 TEXAS BOARD OF PROFESSIONAL ENGINEERS
 CERTIFICATE OF REGISTRATION # F-11852

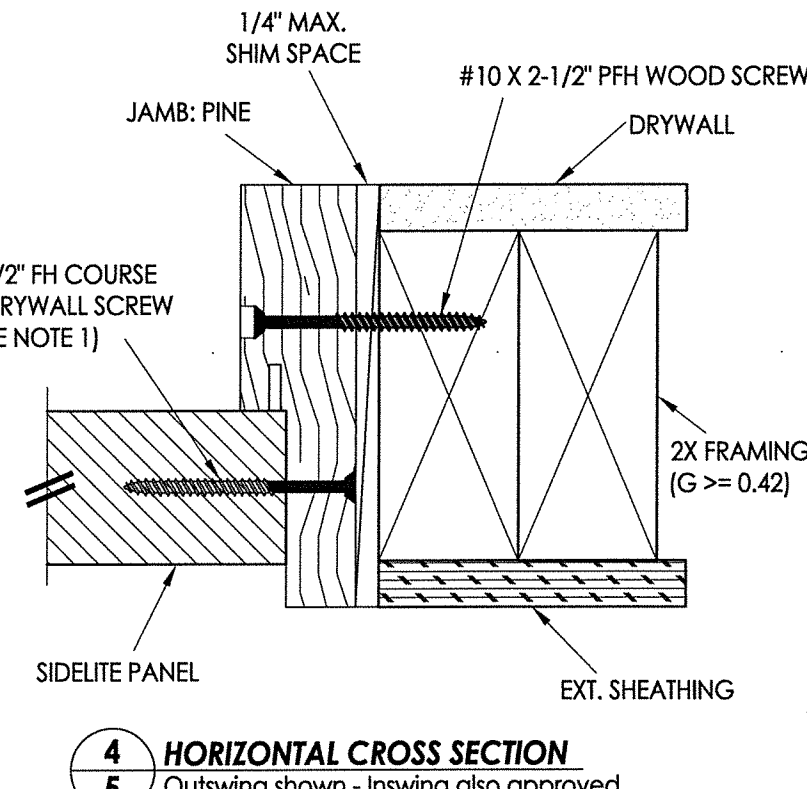
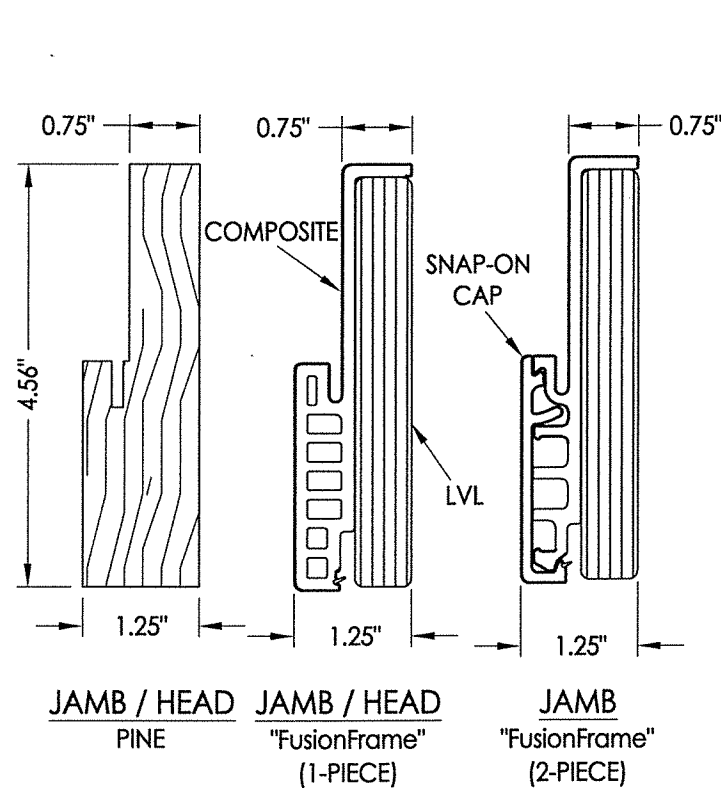

4 HORIZONTAL CROSS SECTION
5 Outswing shown - Inswing also approved

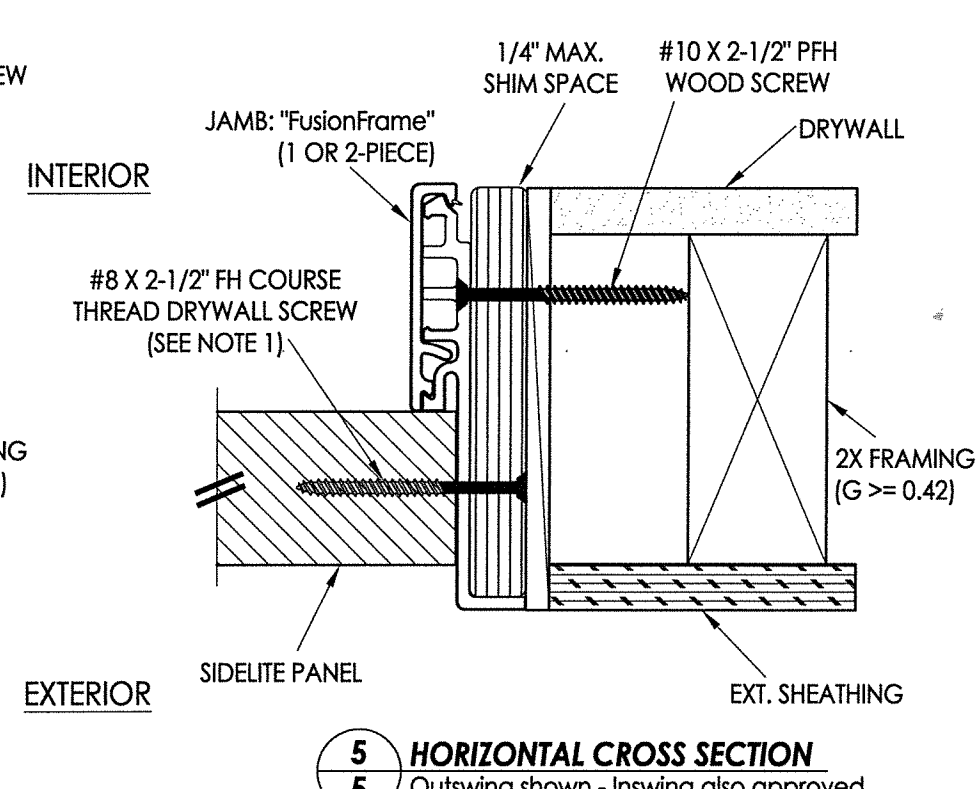

5 HORIZONTAL CROSS SECTION
5 Outswing shown - Inswing also approved

PRODUCT:	ENDURA	
PART OR ASSEMBLY:	VERTICAL CROSS SECTIONS	
NO.	DATE	BY
1	9/23/19	LFS
ADD "FusionFrame" OPTION & UPDATE TO 2018 IBC/IRC CODE		
REVISIONS		
DATE:	11/8/18	
SCALE:	N.T.S.	
DWG. BY:	JK	
CHK. BY:	LFS	
DRAWING NO.:	TX-4905	
SHEET	5	OF 7

R:\Clients\Endura PERMANENT\B - Texas Dept of Ins\TDI - DR-1018 Flush GLZ Masonite FG door (4904-4909)\C - Drawings\TX-4905-08.dwg, 6.3

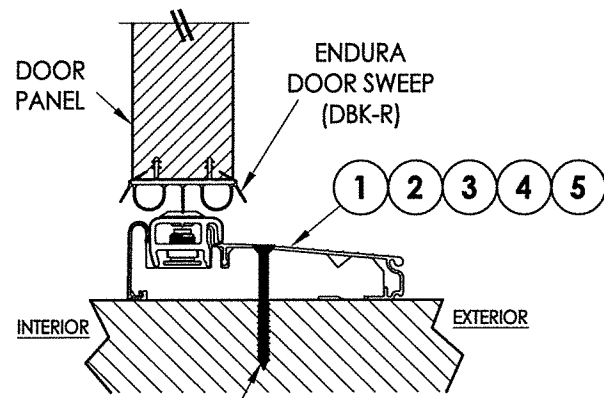

#10 X 2.5" PFH WOOD SCREW OR
1/4" X 2-3/4" ELCO OR ITW CONCRETE SCREW

1 VERTICAL CROSS SECTION
6 Inswing Adjustable Threshold

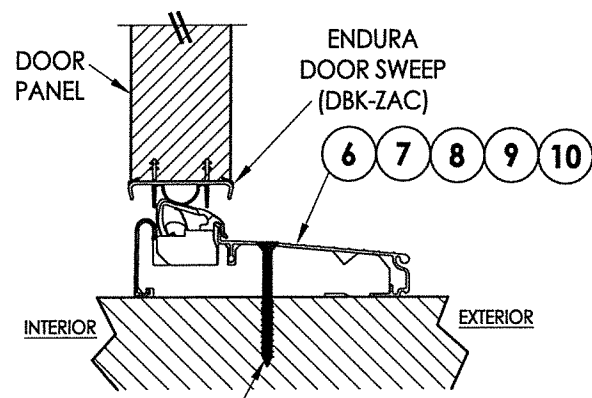

#10 X 2.5" PFH WOOD SCREW OR
1/4" X 2-3/4" ELCO OR ITW CONCRETE SCREW

2 VERTICAL CROSS SECTION
6 Inswing Articulating Threshold

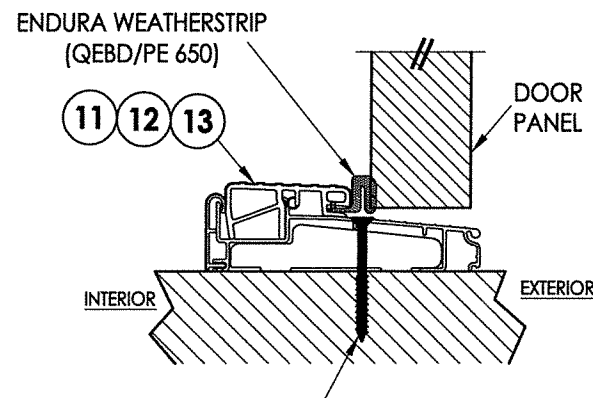

#10 X 2.5" PFH WOOD SCREW OR
1/4" X 2-3/4" ELCO OR ITW CONCRETE SCREW

3 VERTICAL CROSS SECTION
6 Outswing Bump Threshold

NOTE:
1. Spacing for sidelite screws:
6" from each end (2 total).

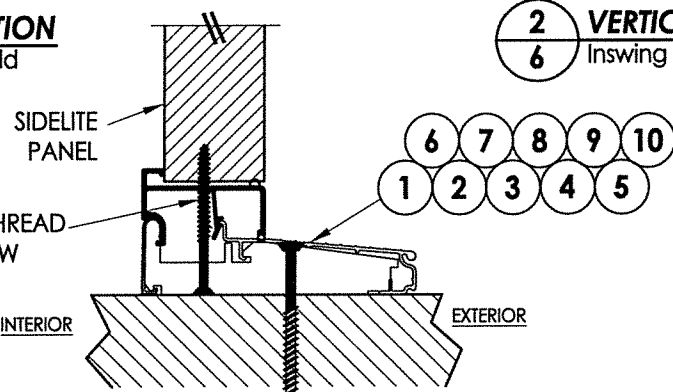

#8 X 2.5" COURSE THREAD
DRYWALL SCREW
(SEE NOTE 1)

#10 X 2.5" PFH WOOD SCREW OR
1/4" X 2-3/4" ELCO OR ITW CONCRETE SCREW

4 VERTICAL CROSS SECTION
6 Inswing configuration

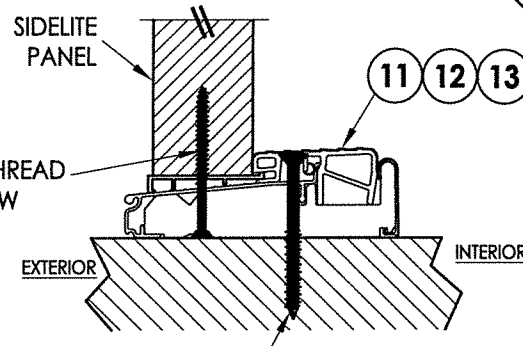

#8 X 2.5" COURSE THREAD
DRYWALL SCREW
(SEE NOTE 1)

#10 X 2.5" PFH WOOD SCREW OR
1/4" X 2-3/4" ELCO OR ITW CONCRETE SCREW

5 VERTICAL CROSS SECTION
6 Outswing configuration

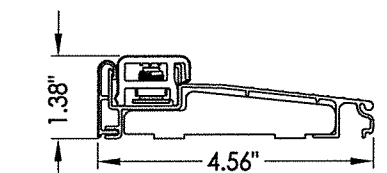

1 INSWING ADJUSTABLE THRESHOLD
ZAIL4565

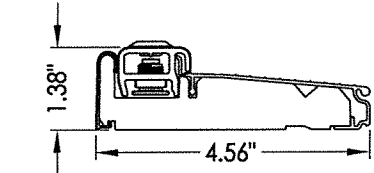

2 INSWING ADJUSTABLE THRESHOLD
ZAI4565FN

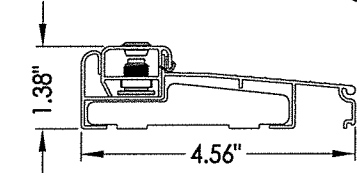

3 INSWING ADJUSTABLE THRESHOLD
ZAILAA4565

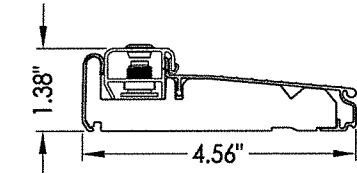

4 INSWING ADJUSTABLE THRESHOLD
ZAI4565FN

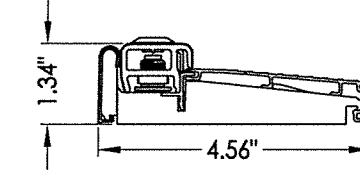

5 INSWING ADJUSTABLE THRESHOLD
ZAI4565RDS

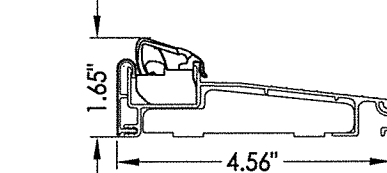

6 INSWING ARTICULATING THRESHOLD
ZACL4565

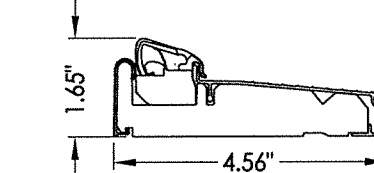

7 INSWING ARTICULATING THRESHOLD
ZAC4565FN

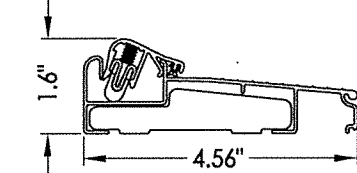

8 INSWING ARTICULATING THRESHOLD
ZACLA4565

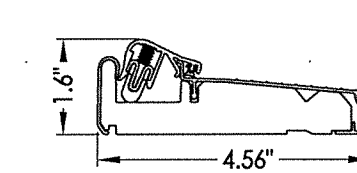

9 INSWING ARTICULATING THRESHOLD
ZACAA4565FN

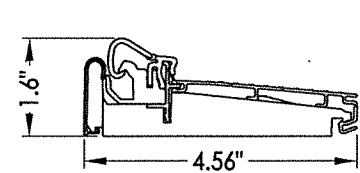

10 INSWING ARTICULATING THRESHOLD
ZAC4565RDS

MAX. DESIGN PRESSURE = ±45 PSF

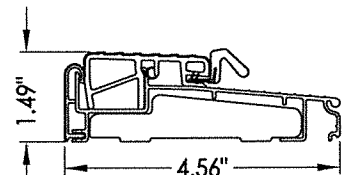

11 OUTSWING THRESHOLD
ZOBL4565

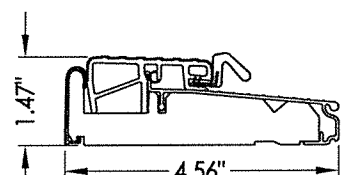

12 OUTSWING THRESHOLD
ZOB4565FN

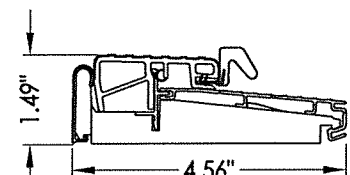

13 OUTSWING THRESHOLD
ZOB4565RDS

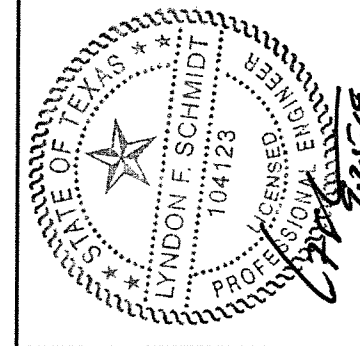

Documents Prepared By: Lyndon F. Schmidt, P.E.
TEXAS P.E. #104123

RW BUILDING CONSULTANTS, INC.
P.O. Box 230 Vairico FL 33595
Phone No.: 813.659.9197

TEXAS BOARD OF PROFESSIONAL ENGINEERS
CERTIFICATE OF REGISTRATION # F-11852

PRODUCT: ENDURA
FIBERGLASS DOOR
PART OR ASSEMBLY: LFS
VERTICAL CROSS SECTIONS

NO.	DATE	REVISIONS
1	9/23/19	ADD "FusionFrame" OPTION & UPDATE TO 2018 IBC/IRC CODE

DATE: 11/8/18
SCALE: N.T.S.
DWG. BY: JK
CHK. BY: LFS
DRAWING NO.: TX-4905
SHEET 6 OF 7

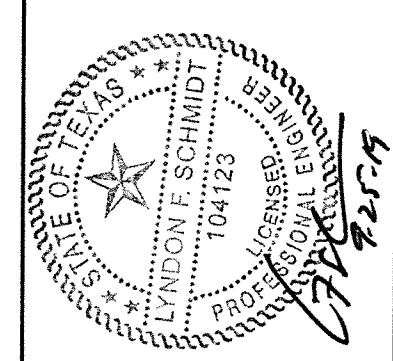
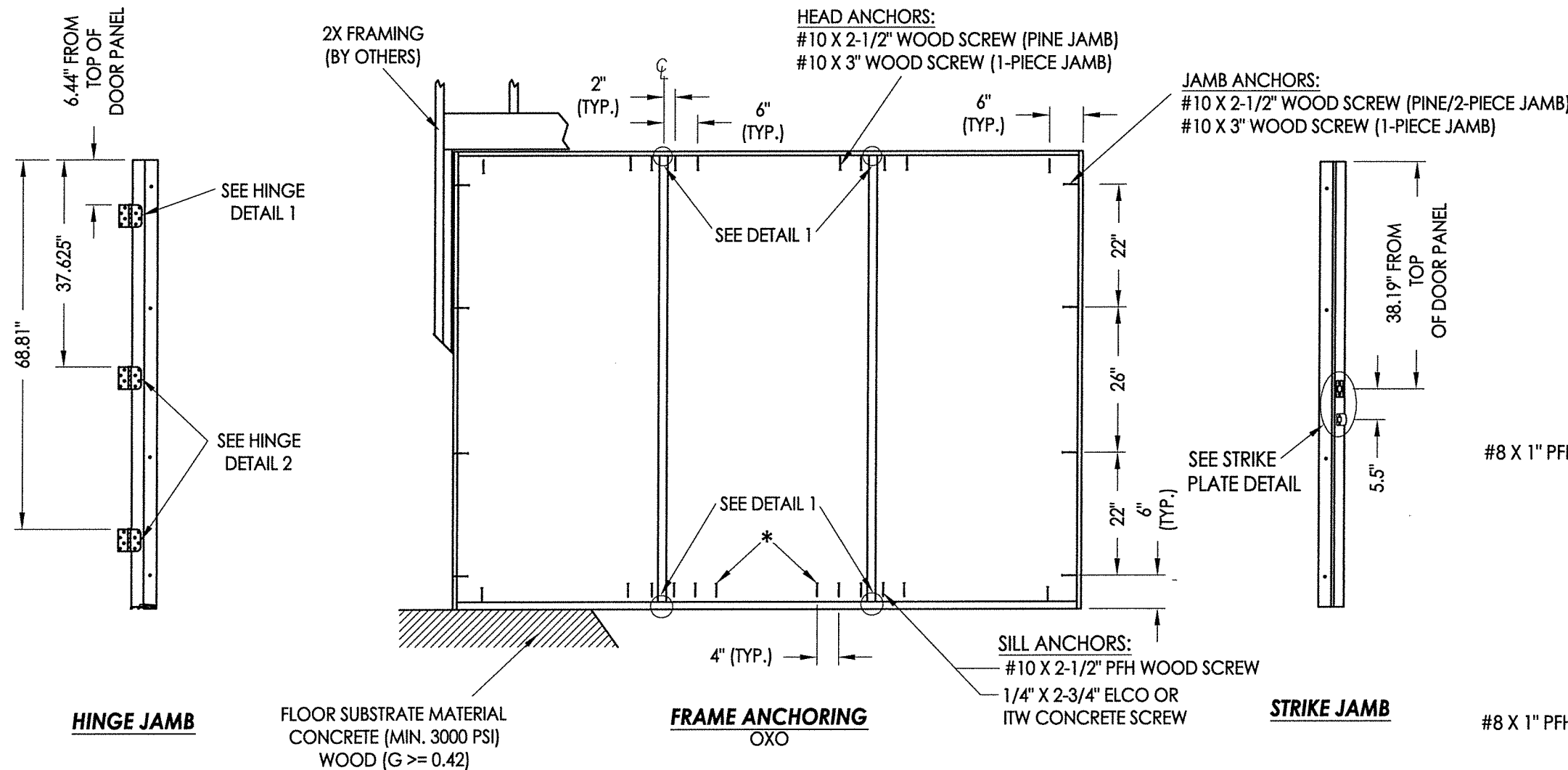

Documents Prepared By: Lyndon F. Schmidt, P.E.
 TEXAS P.E. #104123

RW BUILDING CONSULTANTS, INC.
 P.O. Box 230 Volrico FL 33595
 Phone No.: 813.659.9197

TEXAS BOARD OF PROFESSIONAL ENGINEERS
 CERTIFICATE OF REGISTRATION # F-11852

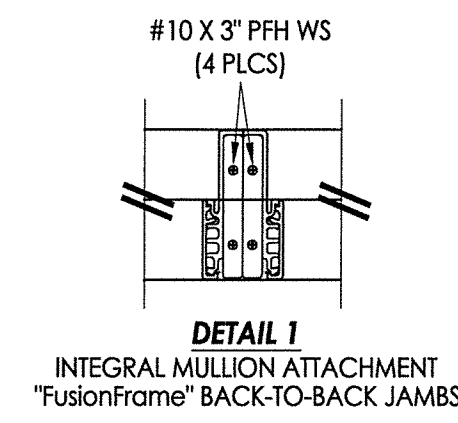
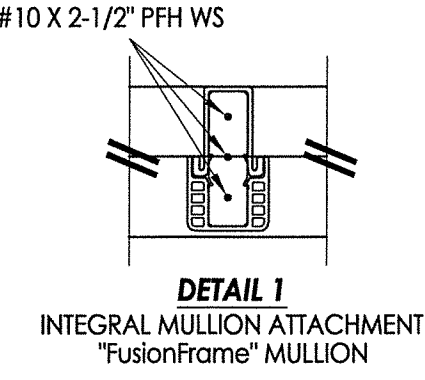
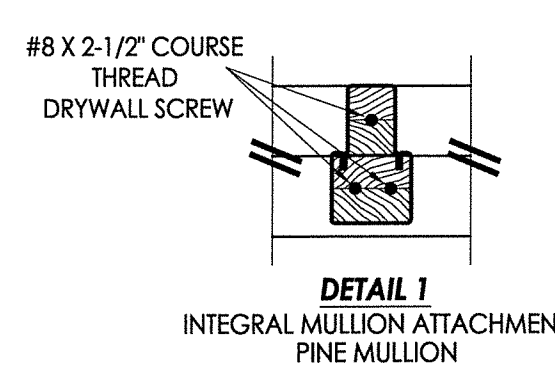
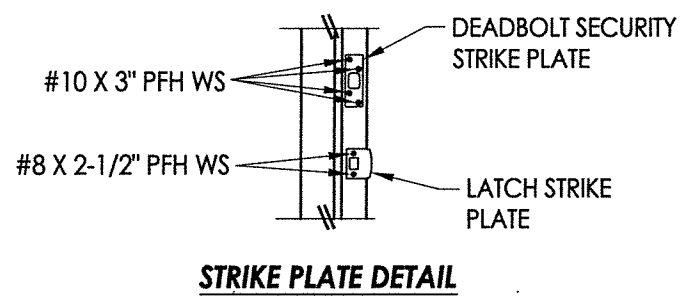
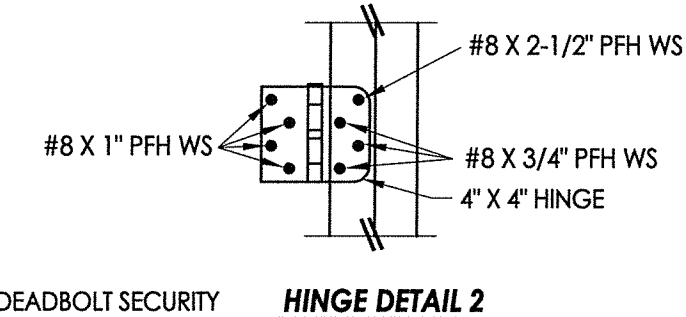
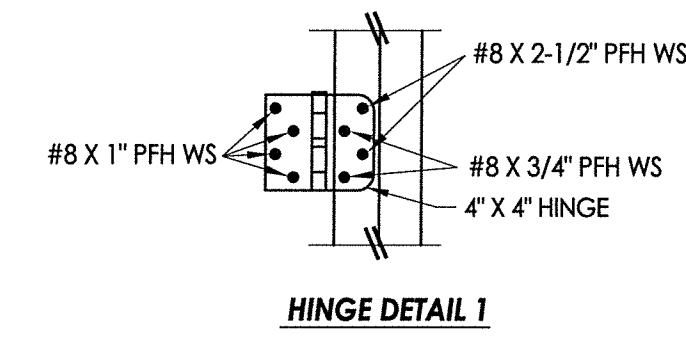

* NOTE: THESE ADDITIONAL ANCHORS ARE REQUIRED FOR D.P. > 40 PSF.

- JAMB NOTES:**
 THE PINE OR "FusionFrame" 1-PIECE JAMB MAY BE INSTALLED @ THE HEAD OR SIDE JAMB.
 THE FusionFrame" 2-PIECE JAMB MAY BE INSTALLED @ THE SIDE JAMBS ONLY.
- INTEGRAL MULLION NOTES:**
 THE FATBOY PINE MULLION, "FusionFrame" MULLION, OR THE "FusionFrame" BACK-TO-BACK JAMB (1-PIECE OR 2-PIECE) MAY ALL BE USED AS THE INTEGRAL MULLION.
- CONCRETE ANCHOR NOTES:**
- Concrete anchor locations at the corners may be adjusted to maintain the min. edge distance to mortar joints.
 - Concrete anchor locations noted as "MAX. ON CENTER" must be adjusted to maintain the min. edge distance to mortar joints, additional concrete anchors may be required to ensure the "MAX. ON CENTER" dimension are not exceeded.
 - Concrete anchor table:

ANCHOR TYPE	ANCHOR SIZE	MIN. EMBEDMENT	MIN. CLEARANCE TO MASONRY EDGE	MIN. CLEARANCE TO ADJACENT ANCHOR
ITW TAPCON®	1/4"	1-3/4"	2-1/2"	3"
ELCO ULTRACON®	1/4"	1-3/4"	1"	3"

PRODUCT:	ENDURA	
PART OR ASSEMBLY:	FRAME ANCHORING	
NO.	DATE	BY
1	9/23/19	LFS
ADD "FusionFrame" OPTION & UPDATE TO 2018 IBC/IRC CODE		
DATE:	11/8/18	
SCALE:	N.T.S.	
DWG. BY:	JK	
CHK. BY:	LFS	
DRAWING NO.:	TX-4905	
SHEET	7 OF 7	