

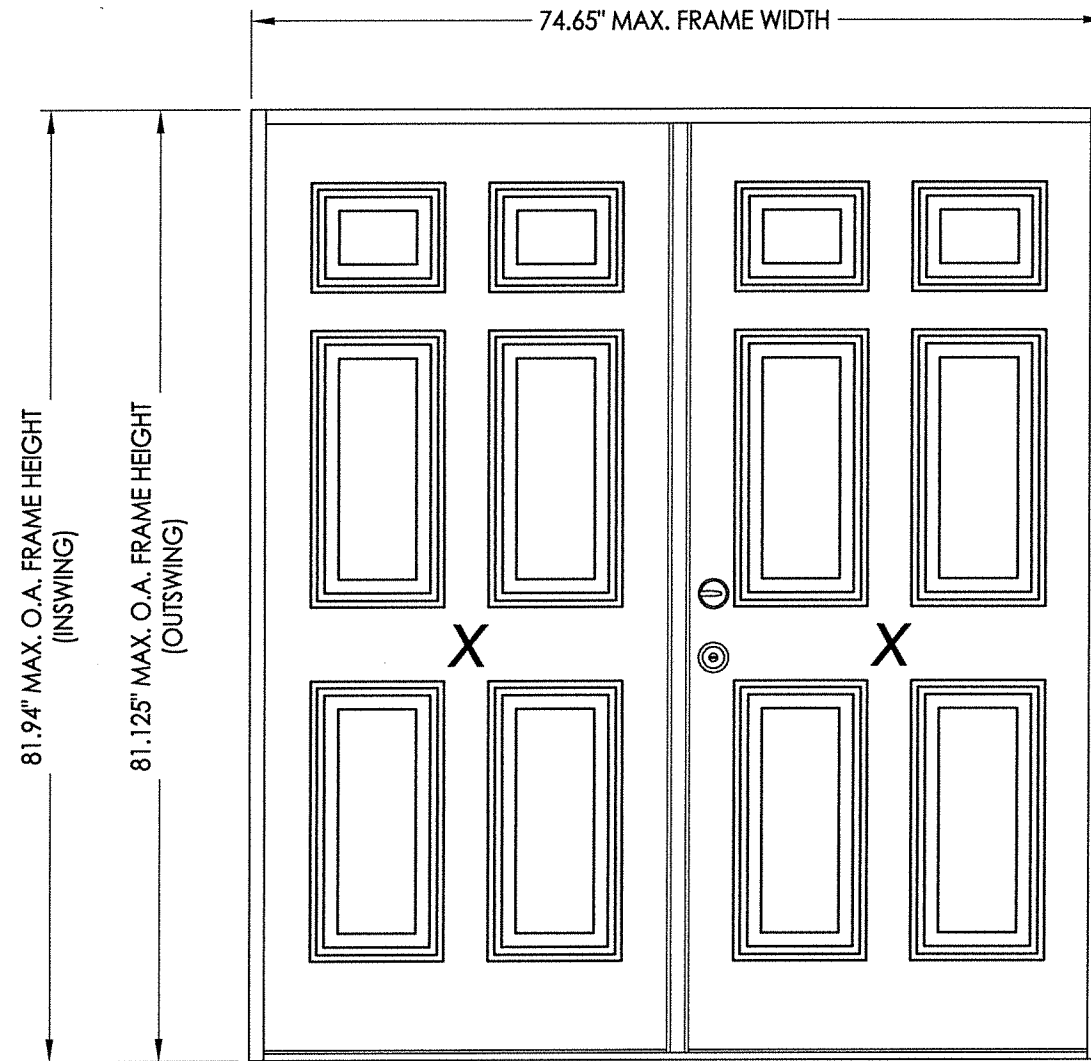

Opaque Fiberglass Door

"NON-IMPACT"
INSWING / OUTSWING



EVALUATED FOR USE IN THE STATE OF TEXAS

The Opaque Fiberglass Door system described herein complies with the 2018 International Residential Code (IRC), Sections R301 & R609 and the 2018 International Building Code (IBC), Sections 1404.13, 1609, 1709.5, 2403 and 2404 subject to the following conditions:

1. Anchors shall be as listed and spaced as shown in the details. Anchor embedment to base material shall be beyond wall dressing or stucco.
2. When used in areas requiring wind-borne debris protection this product is required to be protected with an impact resistant covering that complies with Section R301.2.1.2 of the IRC and Section 1609.2 of the IBC.
3. Allowable design pressure requirements must be equal to or less than the design pressure rating shown in the design pressure chart, sheet 1 of this drawing.
4. Conditions not covered by this drawing are subject to further engineering analysis.

TABLE OF CONTENTS

SHEET #	DESCRIPTION
1	Typical elevations, design pressures & general notes
2	Astragal details
3	Door panel details
4	Horizontal & vertical cross sections
5	Vertical cross sections
6	Frame anchoring

MODEL	DESIGN PRESSURE (PSF) w/ PINE FRAME & FATBOY PINE MULLIONS		DESIGN PRESSURE (PSF) w/ "FusionFrame" FRAME & MULLIONS	
	POSITIVE	NEGATIVE	POSITIVE	NEGATIVE
INSWING	+50.0	-55.0	+50.0	-50.0
OUTSWING	+60.0	-60.0	+50.0	-50.0

SEE SHEET 5 FOR THRESHOLD DESIGN PRESSURE LIMITATIONS

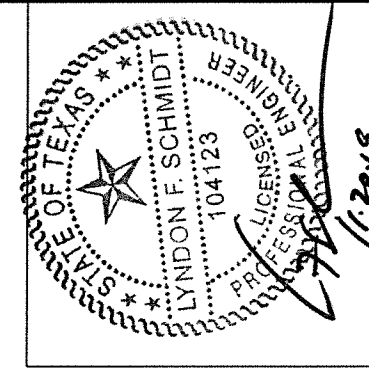

Documents Prepared By: Lyndon F. Schmidt, P.E.
TEXAS P.E. #104123

RW BUILDING CONSULTANTS, INC.
P.O. Box 230 Valrico FL 33595
Phone No.: 813.659.9197
TEXAS BOARD OF PROFESSIONAL ENGINEERS
CERTIFICATE OF REGISTRATION # F-11852

PRODUCT: ENDURA
PART OR ASSEMBLY:
TYPICAL ELEVATION, DESIGN PRESSURES & GENERAL NOTES

NO.	DATE	REVISIONS
1	11/20/19	ADD "FusionFrame" OPTION & UPDATE TO 2018 IBC/IRC CODE

DATE: 10/31/18
SCALE: N.T.S.
DWG. BY: JK
CHK. BY: LFS
DRAWING NO.: TX-4894
SHEET 1 OF 6

R:\Clients\Endura PERMANENT\B - Texas Dept of Ins\TDI - DR-1011 Opaque Therma-Tru FG door XX (LK, DB) (4894-4895)\C - Drawings\TX-4894-95.dwg, 1-2

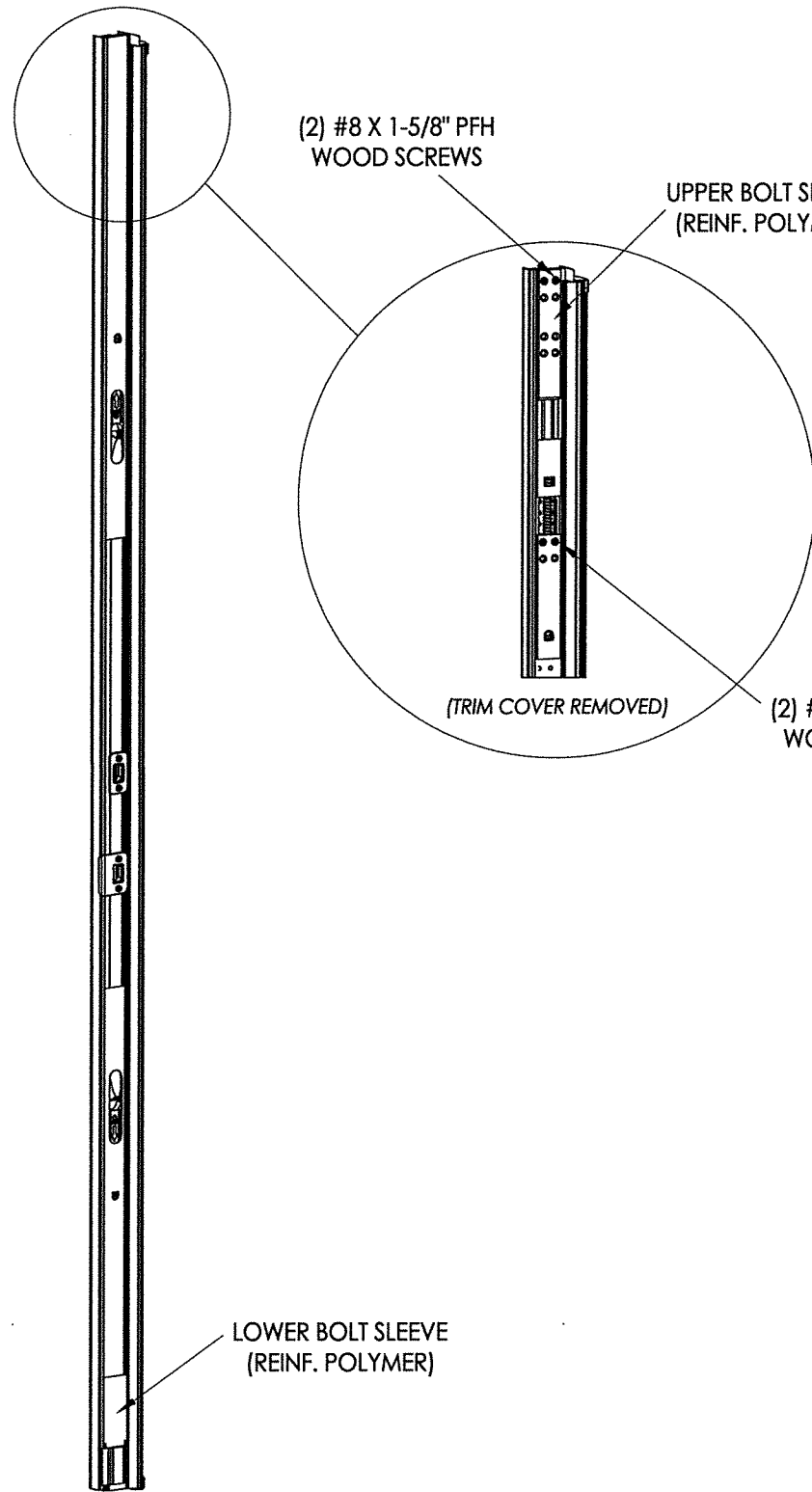

ULTIMATE/ULTIMATE COMPATIBLE HURRICANE ASTRAGAL

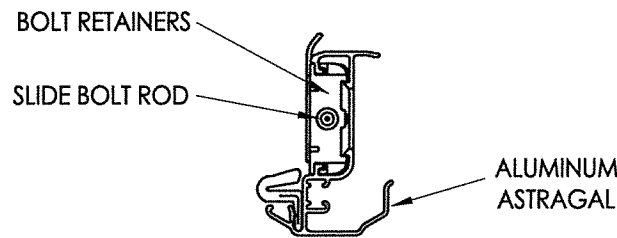
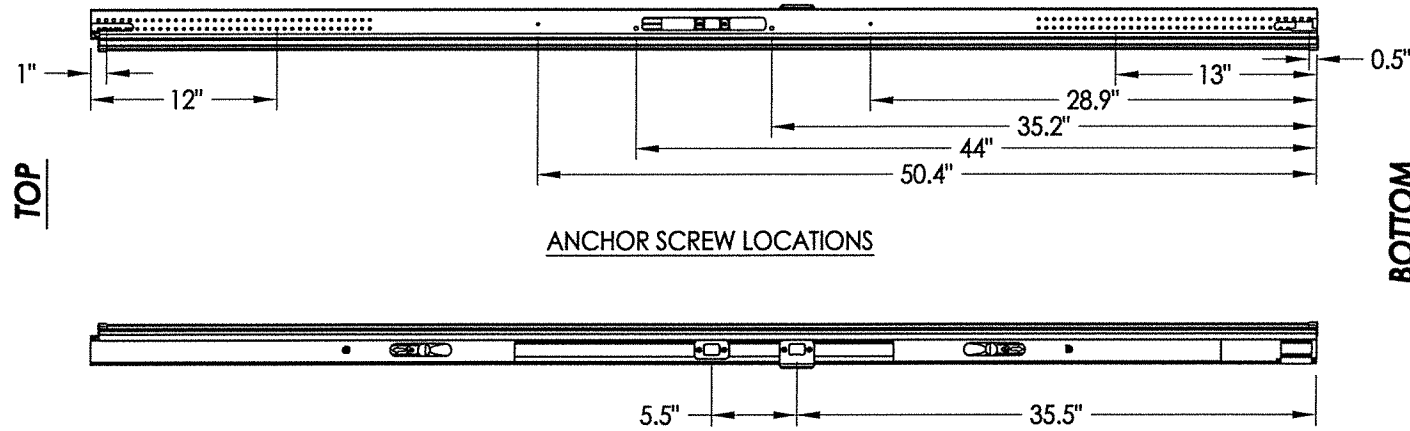

ALUMINUM ASTRAGAL ASSEMBLY

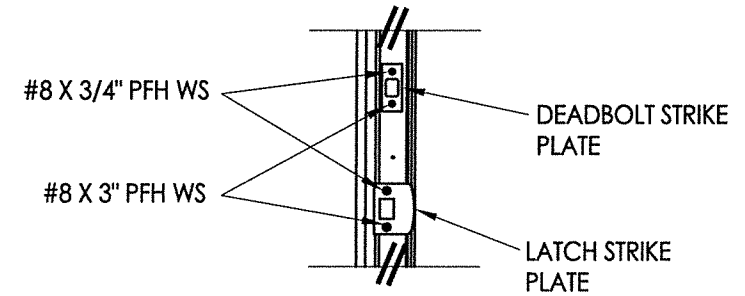

LATCH & DEADBOLT DETAIL

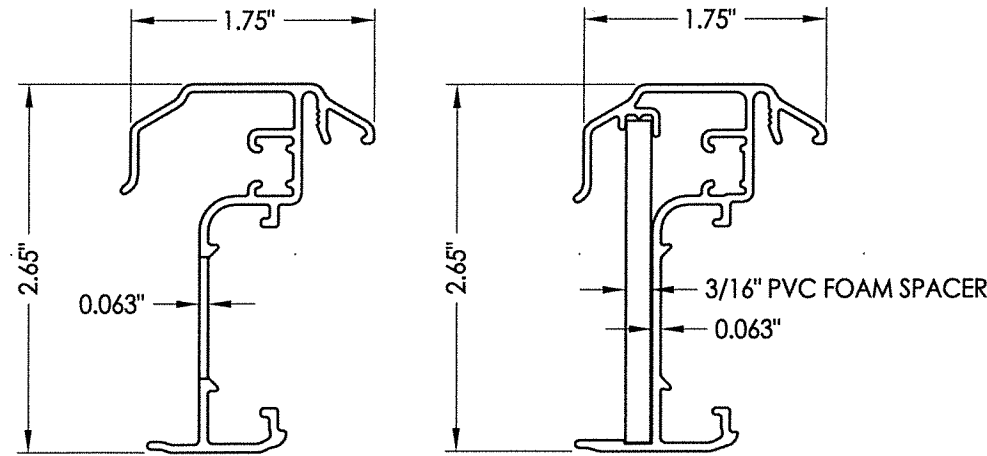

ULTIMATE HURRICANE ASTRAGAL

ULTIMATE COMPATIBLE* HURRICANE ASTRAGAL (OPTIONAL)

ASTRAGAL SECTIONS

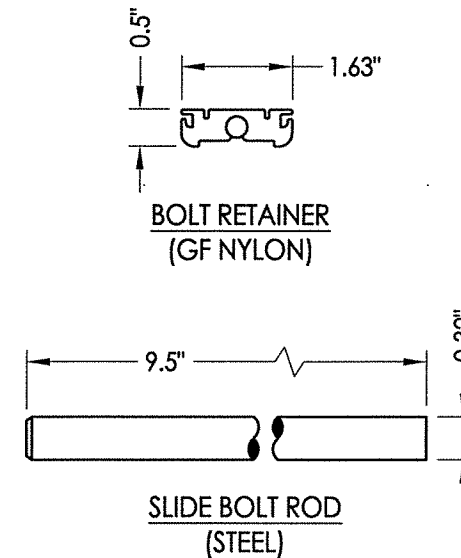

* NOTE: INCREASE THE MAXIMUM FRAME WIDTH BY 3/16" TO ACCOMODATE THE OPTIONAL ULTIMATE COMPATIBLE HURRICANE ASTRAGAL WHEN USED.

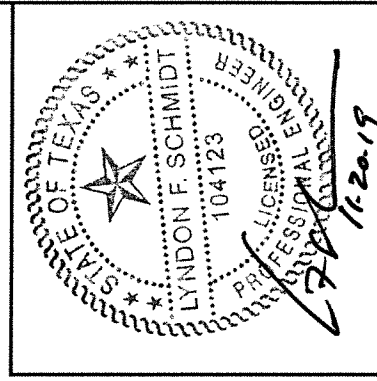

Documents Prepared By: Lyndon F. Schmidt, P.E.
TEXAS P.E. #104123

RW BUILDING CONSULTANTS, INC.
P.O. Box 230 Valrico FL, 33595
Phone No.: 813.659.9197

TEXAS BOARD OF PROFESSIONAL ENGINEERS
CERTIFICATE OF REGISTRATION # F-11852

PRODUCT: ENDURA		PART OR ASSEMBLY: ASTRAGAL DETAILS	
NO.	DATE	BY	REVISIONS
1	11/20/19	LFS	ADD "FusionFrame" OPTION & UPDATE TO 2018 IBC/IRC CODE
DATE: 10/31/18		SCALE: N.T.S.	
DWG. BY: JK		CHK. BY: LFS	
DRAWING NO.: TX-4894		SHEET 2 OF 6	

R:\Clients\Endura PERMANENT\B - Texas Dept of Ins\TDI - DR-1011 Opaque Thermo-Tru FG door XX (LK, DB) (4894-4895)\C - Drawings\TX-4894-95.dwg, 1-3

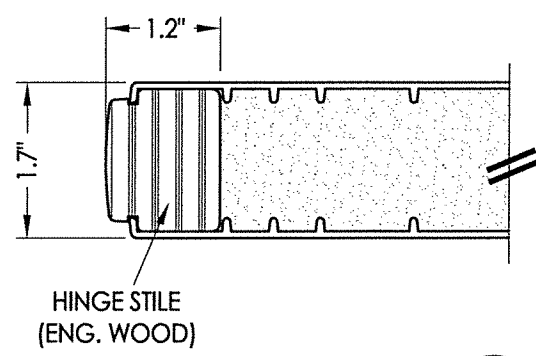

EXTERIOR

INTERIOR

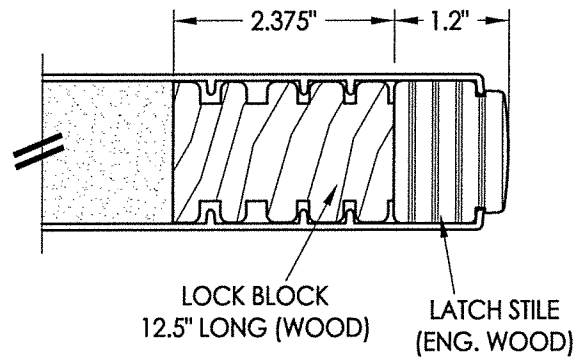

LOCK BLOCK
12.5" LONG (WOOD)

LATCH STILE
(ENG. WOOD)

1
3 **HORIZONTAL CROSS SECTION**

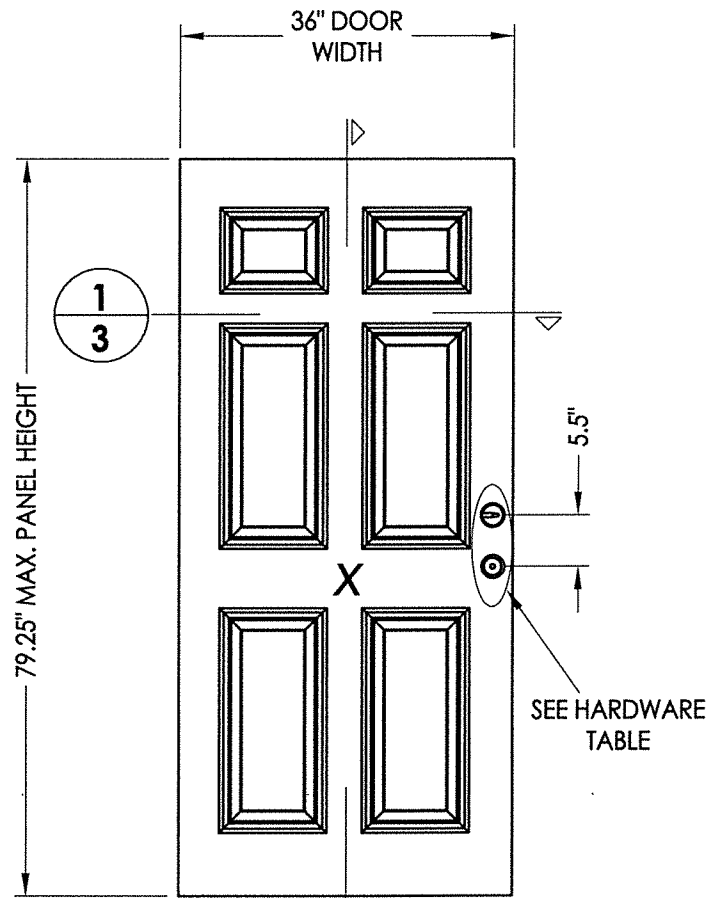

2
3 **40 DOOR PANEL**
Therma-Tru Fiberglass

HARDWARE TABLE	
MANUFACTURER	MODEL
KWIKSET	LATCH: KWIKSET SIGNATURE SERIES (991) DEADBOLT: KWIKSET SIGNATURE SERIES (980/985)

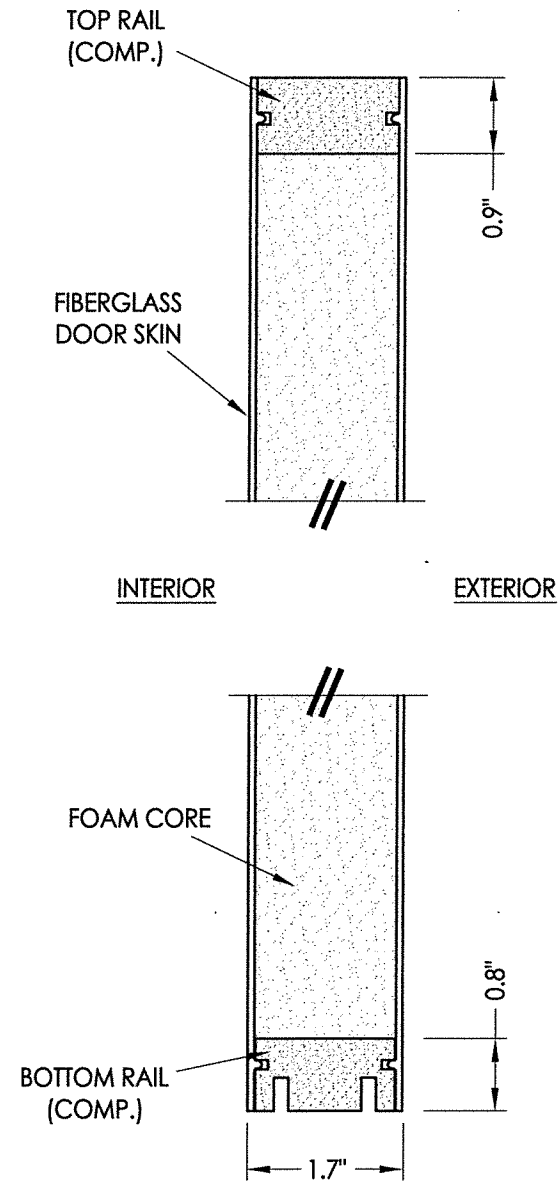

2
3 **VERTICAL CROSS SECTION**

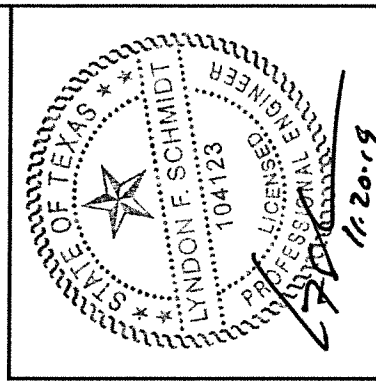

Documents Prepared By: Lyndon F. Schmidt, P.E.
TEXAS P.E. #104123

RW BUILDING CONSULTANTS, INC.
P.O. Box 230 Valrico FL 33595
Phone No.: 813.659.9197

TEXAS BOARD OF PROFESSIONAL ENGINEERS
CERTIFICATE OF REGISTRATION # F-11852

PRODUCT:	ENDURA	
PART OR ASSEMBLY:	DOOR PANEL DETAILS	
NO.	DATE	BY
1	11/20/19	LFS
ADD "FusionFrame" OPTION & UPDATE TO 2018 IBC/IRC CODE		
REVISIONS		
DATE: 10/31/18		
SCALE: N.T.S.		
DWG. BY: JK		
CHK. BY: LFS		
DRAWING NO.: TX-4894		
SHEET 3 OF 6		

DOOR SKIN: FIBERGLASS (0.075" MIN. THICKNESS)
CORE MATERIAL: POLYURETHANE FOAM

© 2018 R.W. BUILDING CONSULTANTS INC.

R:\Clients\Endura PERMANENT\B - Texas Dept of Ins\TDI - DR-1011 Opaque Therma-Tru FG door XX (LK, DB) (4894-4895)\C - Drawings\TX-4894-95.dwg, 1-4

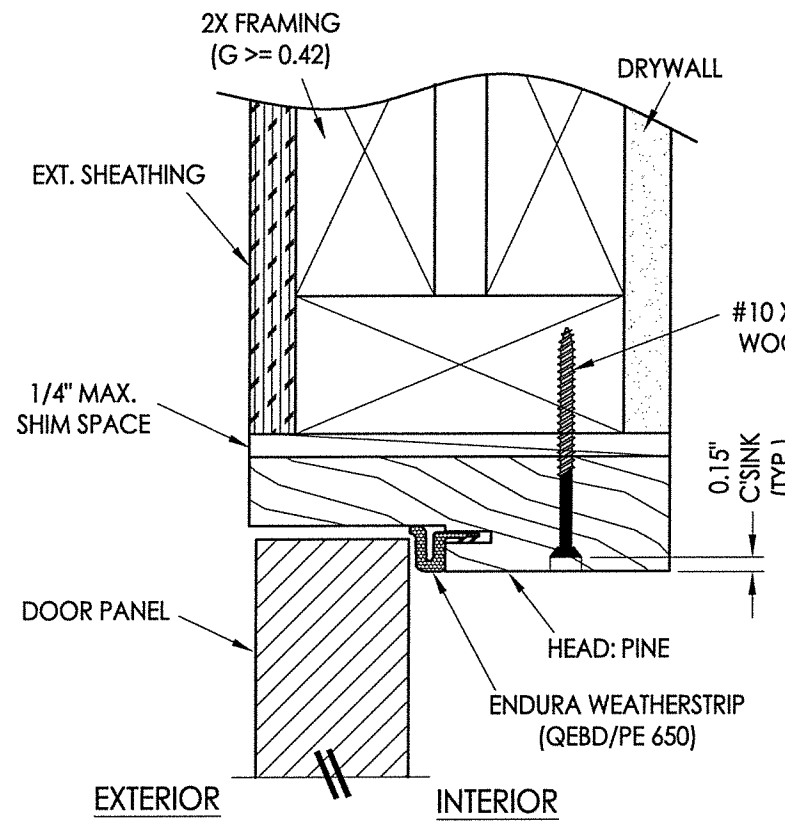
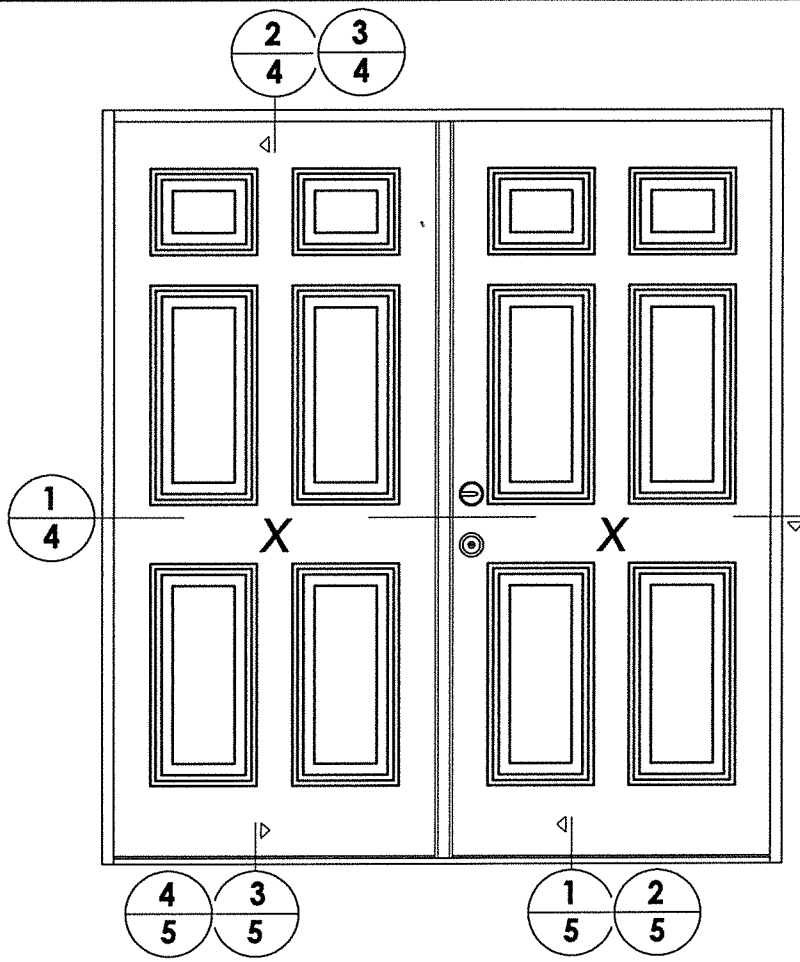

2 VERTICAL CROSS SECTION
4 Outswing shown - inswing also approved

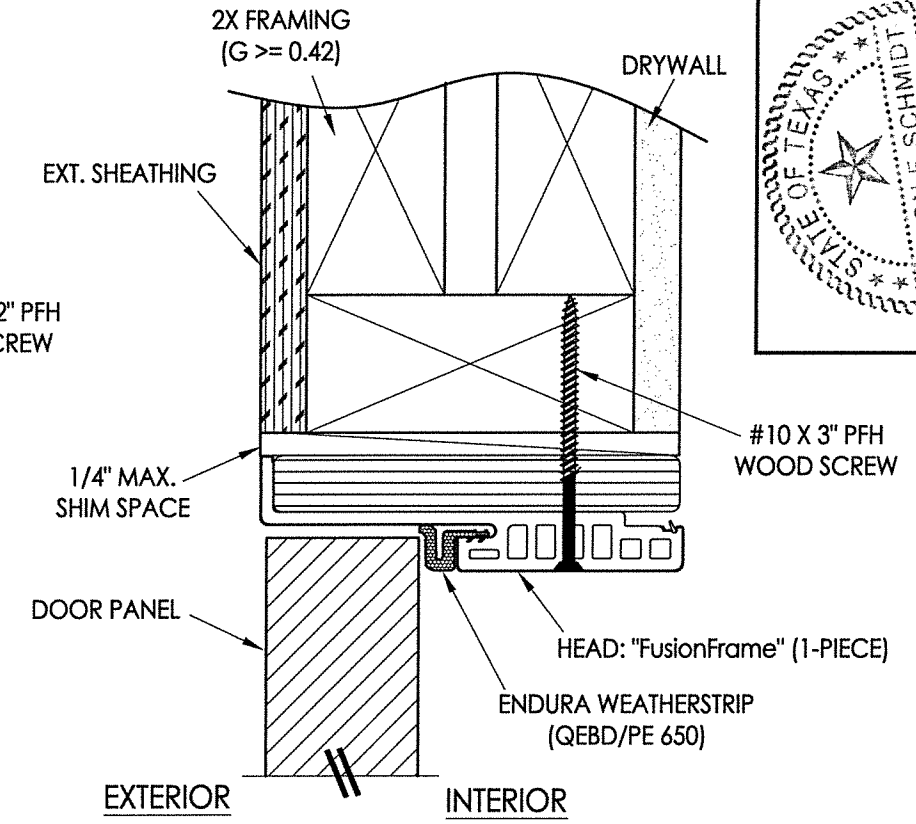

3 VERTICAL CROSS SECTION
4 Outswing shown - inswing also approved

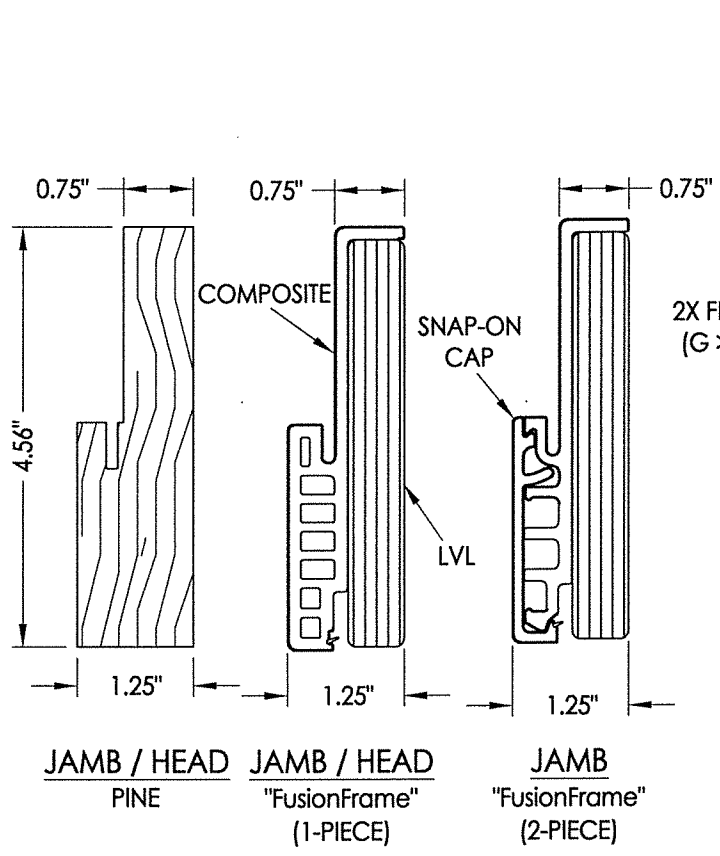

1 HORIZONTAL CROSS SECTION
4 Inswing shown - Outswing also approved

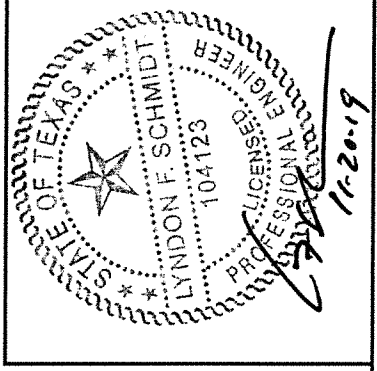
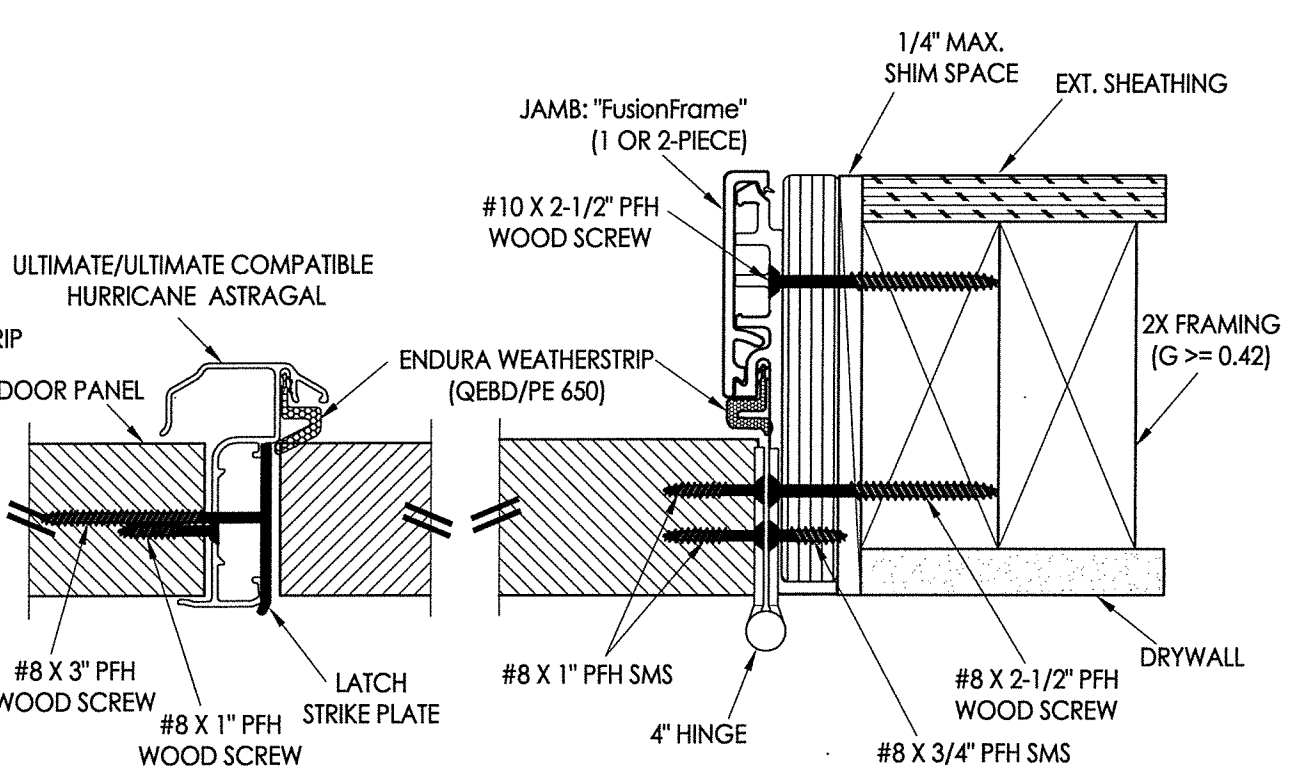
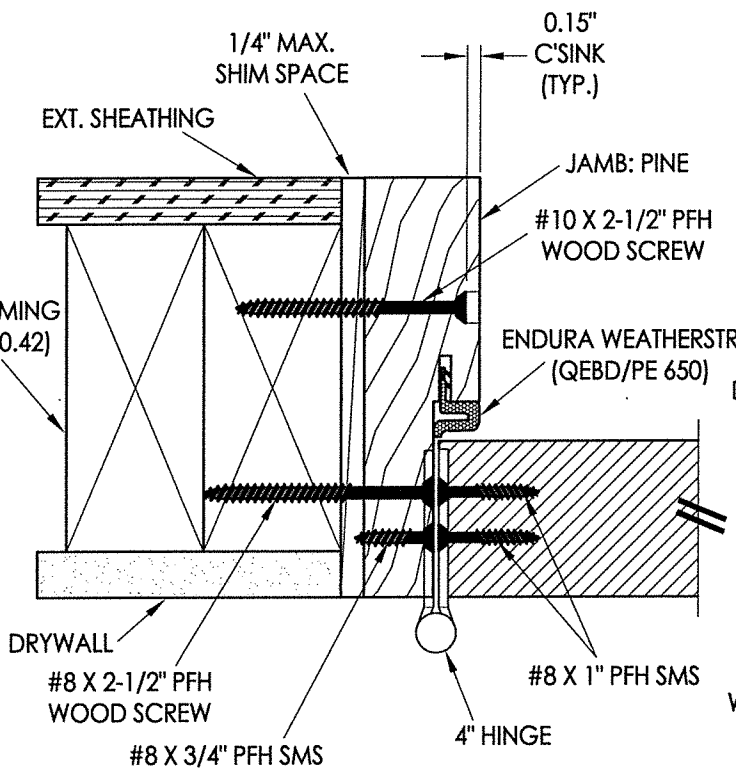

Documents Prepared By: Lyndon F. Schmidt, P.E.
 TEXAS P.E. #104123

RW BUILDING CONSULTANTS, INC.
 P.O. Box 230 Valrico FL 33595
 Phone No.: 813.659.9197

TEXAS BOARD OF PROFESSIONAL ENGINEERS
 CERTIFICATE OF REGISTRATION # F-11852

PRODUCT:	ENDURA	
PART OR ASSEMBLY:	HORIZONTAL & VERTICAL CROSS SECTIONS	
NO.	DATE	BY
1	11/20/19	LFS
ADD "FusionFrame" OPTION & UPDATE TO 2018 IBC/IRC CODE		
REVISIONS		
DATE:	10/31/18	
SCALE:	N.T.S.	
DWG. BY:	JK	
CHK. BY:	LFS	
DRAWING NO.:	TX-4894	
SHEET	4	OF 6

R:\Clients\Endura PERMANENT.B - Texas Dept of Ins\TDI - DR-1011 Opaque Therma-Tru FG door XX (LK, DB) (4894-4895)\C - Drawings\TX-4894-95.dwg, 1-5

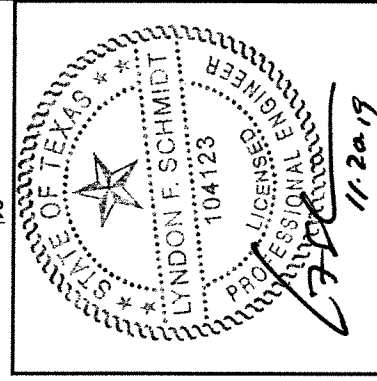
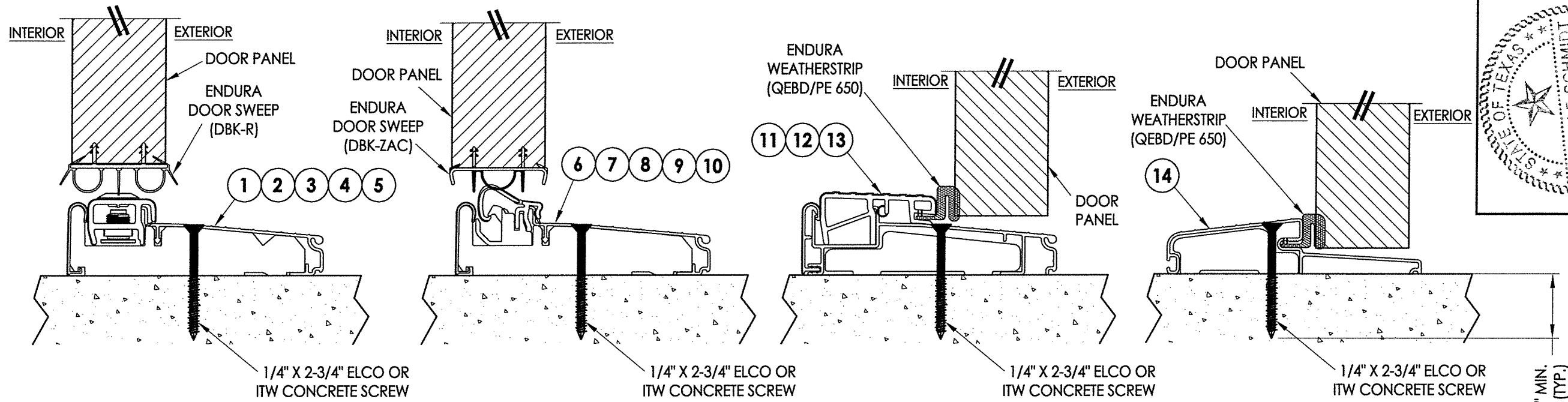

Documents Prepared By: Lyndon F. Schmidt, P.E.
TEXAS P.E. #104123

RW BUILDING CONSULTANTS, INC.
P.O. Box 230 Valrico FL, 33595
Phone No.: 813.659.9197
TEXAS BOARD OF PROFESSIONAL ENGINEERS
CERTIFICATE OF REGISTRATION # F-11852

1 VERTICAL CROSS SECTION
5 Inswing Adjustable Threshold

2 VERTICAL CROSS SECTION
5 Inswing Articulating Threshold w/ Pin Capture

3 VERTICAL CROSS SECTION
5 Outswing Bump Threshold

4 VERTICAL CROSS SECTION
5 Outswing Bump Threshold

1-1/4" MIN.
EMB. (TYP.)

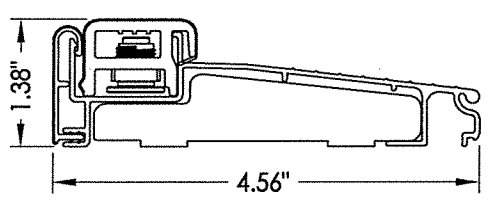

1 INSWING ADJUSTABLE THRESHOLD
ZAIL4565

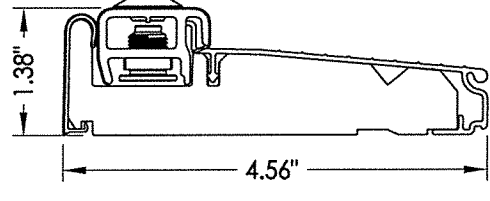

2 INSWING ADJUSTABLE THRESHOLD
ZAI4565FN
MAX. DESIGN PRESSURE = ±45 PSF

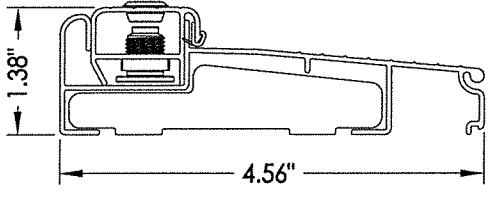

3 INSWING ADJUSTABLE THRESHOLD
ZAILAA4565

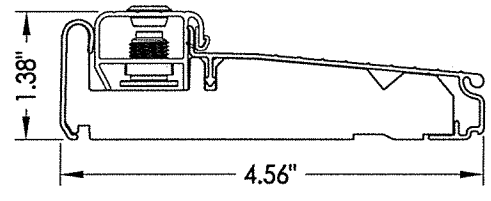

4 INSWING ADJUSTABLE THRESHOLD
ZAIAA4565FN
MAX. DESIGN PRESSURE = ±45 PSF

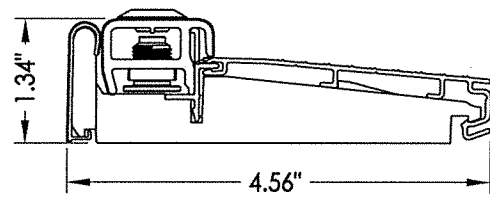

5 INSWING ADJUSTABLE THRESHOLD
ZAI4565RDS
MAX. DESIGN PRESSURE = ±50 PSF

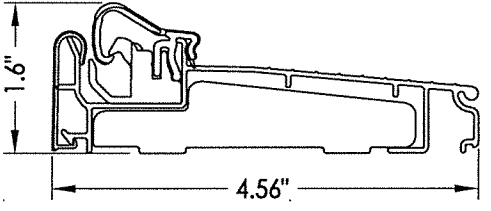

6 INSWING ARTICULATING THRESHOLD
ZACL4565
MAX. DESIGN PRESSURE = ±45 PSF

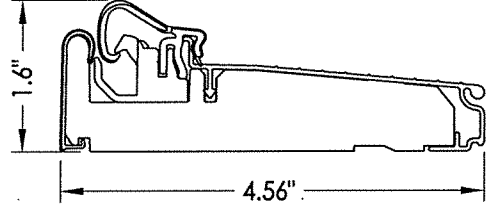

7 INSWING ARTICULATING THRESHOLD
ZAC4565FN
MAX. DESIGN PRESSURE = ±45 PSF

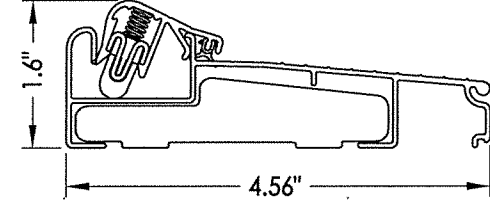

8 INSWING ARTICULATING THRESHOLD
ZACLAA4565
MAX. DESIGN PRESSURE = ±45 PSF

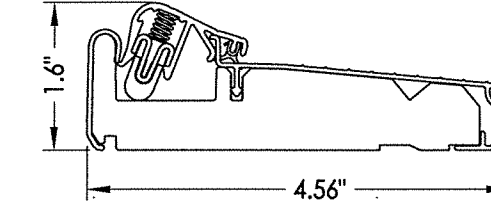

9 INSWING ARTICULATING THRESHOLD
ZACAA4565FN
MAX. DESIGN PRESSURE = ±45 PSF

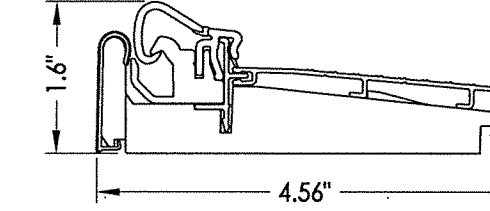

10 INSWING ARTICULATING THRESHOLD
ZAC4565RDS
MAX. DESIGN PRESSURE = ±45 PSF

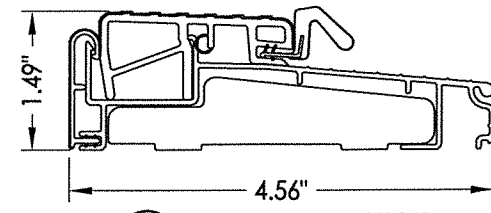

11 OUTSWING THRESHOLD
ZOBL4565

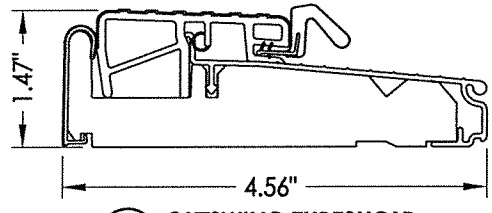

12 OUTSWING THRESHOLD
ZOB4565FN

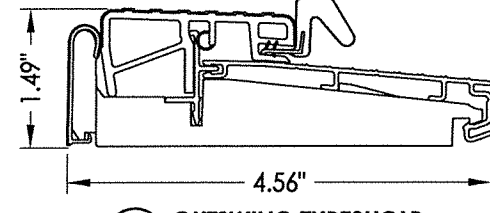

13 OUTSWING THRESHOLD
ZOB4565RDS
MAX. DESIGN PRESSURE = ±55 PSF

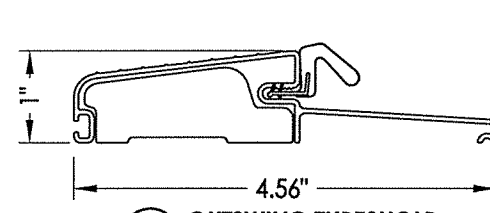

14 OUTSWING THRESHOLD
FOB4566

PRODUCT:	ENDURA	
PART OR ASSEMBLY:	VERTICAL CROSS SECTIONS	
NO.	DATE	BY
1	11/20/19	LFS
ADD "FusionFrame" OPTION & UPDATE TO 2018 IBC/IRC CODE		
REVISIONS		
DATE:	10/31/18	
SCALE:	N.T.S.	
DWG. BY:	JK	
CHK. BY:	LFS	
DRAWING NO.:	TX-4894	
SHEET	5	OF 6

© 2018 R.W. BUILDING CONSULTANTS INC.

R:\Clients\Endura PERMANENT\B - Texas Dept of Ins\TDI - DR-1011 Opaque Therma-Tru FG door XX (LK, DB) (4894-4895)\C - Drawings\TX-4894-95.dwg, 1-6

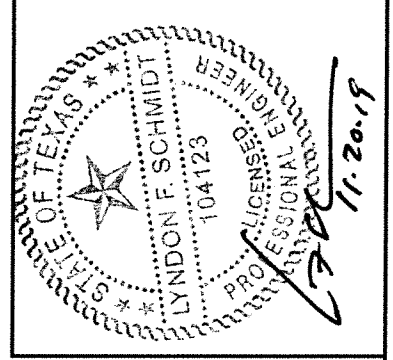
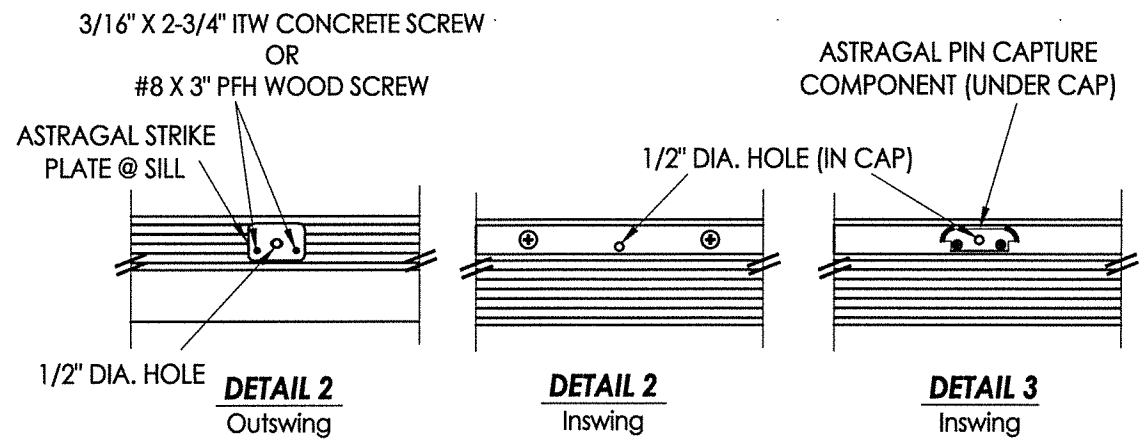
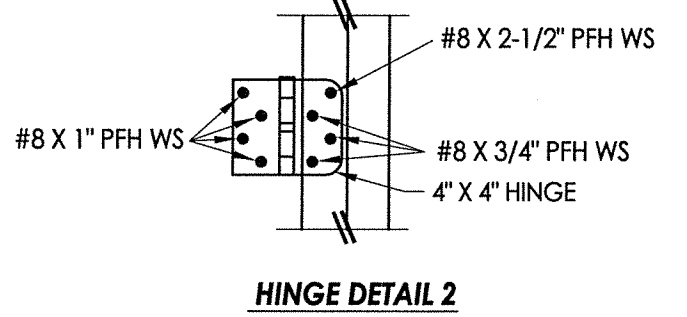
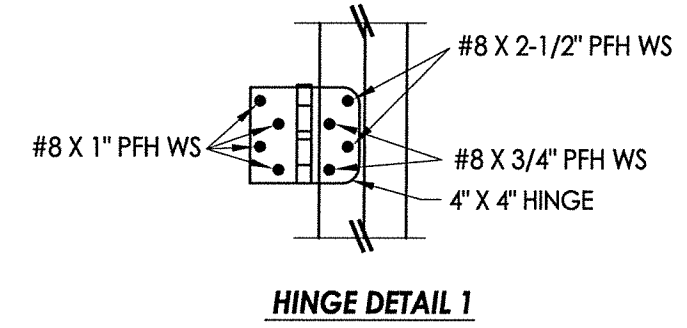
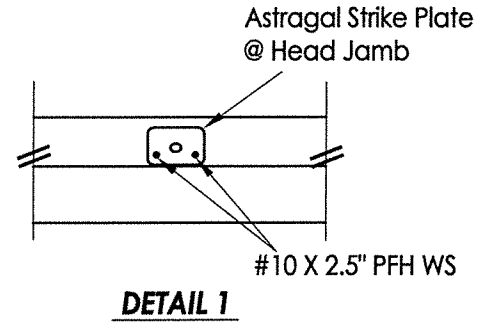
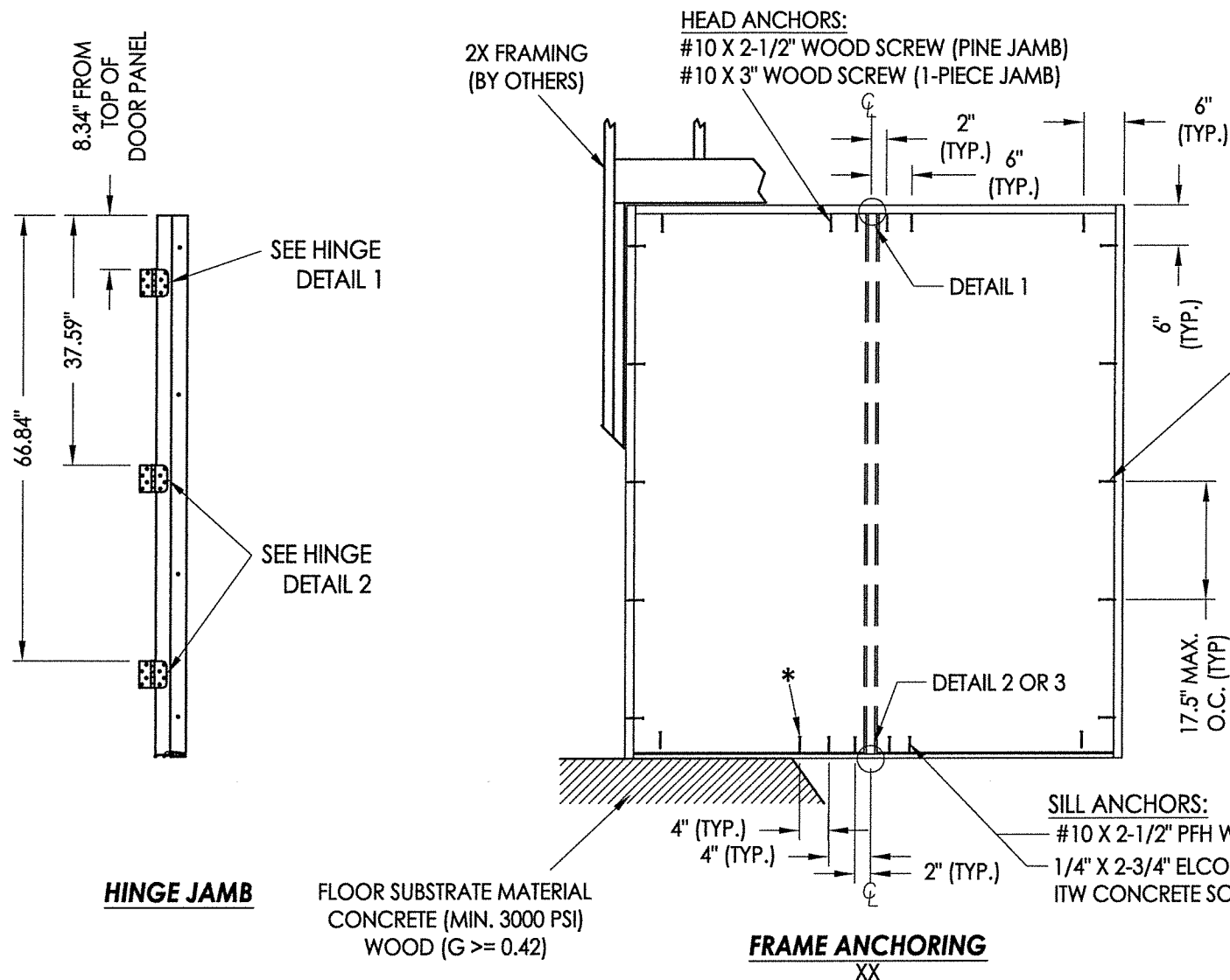

Documents Prepared By: Lyndon F. Schmidt, P.E.
TEXAS P.E. #104123

RW BUILDING CONSULTANTS, INC.
P.O. Box 230 Valrico FL 33595
Phone No.: 813.659.9197

TEXAS BOARD OF PROFESSIONAL ENGINEERS
CERTIFICATE OF REGISTRATION # F-11852

PRODUCT: ENDURA

PART OR ASSEMBLY: FRAME ANCHORING

NO.	DATE	REVISIONS
1	11/20/19	ADD "FusionFrame" OPTION & UPDATE TO 2018 IBC/IRC CODE

DATE: 10/31/18

SCALE: N.T.S.

DWG. BY: JK

CHK. BY: LFS

DRAWING NO.: TX-4894

SHEET 6 OF 6

JAMB NOTES:
THE PINE OR "FusionFrame" 1-PIECE JAMB MAY BE INSTALLED @ THE HEAD OR SIDE JAMB.
THE FusionFrame" 2-PIECE JAMB MAY BE INSTALLED @ THE SIDE JAMBS ONLY.

- CONCRETE ANCHOR NOTES:**
- Concrete anchor locations at the corners may be adjusted to maintain the min. edge distance to mortar joints.
 - Concrete anchor locations noted as "MAX. ON CENTER" must be adjusted to maintain the min. edge distance to mortar joints, additional concrete anchors may be required to ensure the "MAX. ON CENTER" dimension are not exceeded.
 - Concrete anchor table:

ANCHOR TYPE	ANCHOR SIZE	MIN. EMBEDMENT	MIN. CLEARANCE TO MASONRY EDGE	MIN. CLEARANCE TO ADJACENT ANCHOR
ITW TAPCON®	3/16"	1-3/4"	3"	1-1/2"
ITW TAPCON®	1/4"	1-3/4"	1-1/2"	4"
ELCO ULTRACON®	1/4"	1-3/4"	1"	4"

WOOD SCREW INSTALLATION NOTES:

- Maintain a minimum 5/8" edge distance, 1" end distance, & 1" o.c. spacing of wood screws to prevent the splitting of wood.

© 2018 R.W. BUILDING CONSULTANTS INC.