

plastpro

5200 W. CENTURY BLVD.
LOS ANGELES, CA 90045

GLAZED FIBERGLASS DOUBLE DOOR w/ or w/o SIDELITES IN SWING / OUT SWING "IMPACT"

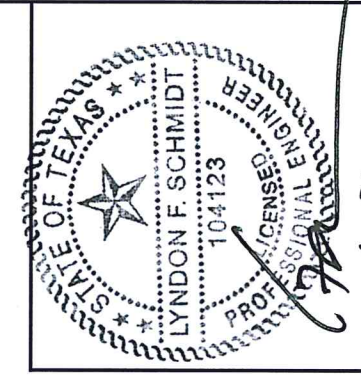

Documents Prepared By: Lyndon F. Schmidt, P.E.
TEXAS P.E. #104123

RW BUILDING CONSULTANTS, INC.
P.O. Box 230 Vairico FL 33595
Phone No.: 813.659.9197
TEXAS BOARD OF PROFESSIONAL ENGINEERS
CERTIFICATE OF REGISTRATION # F-11852

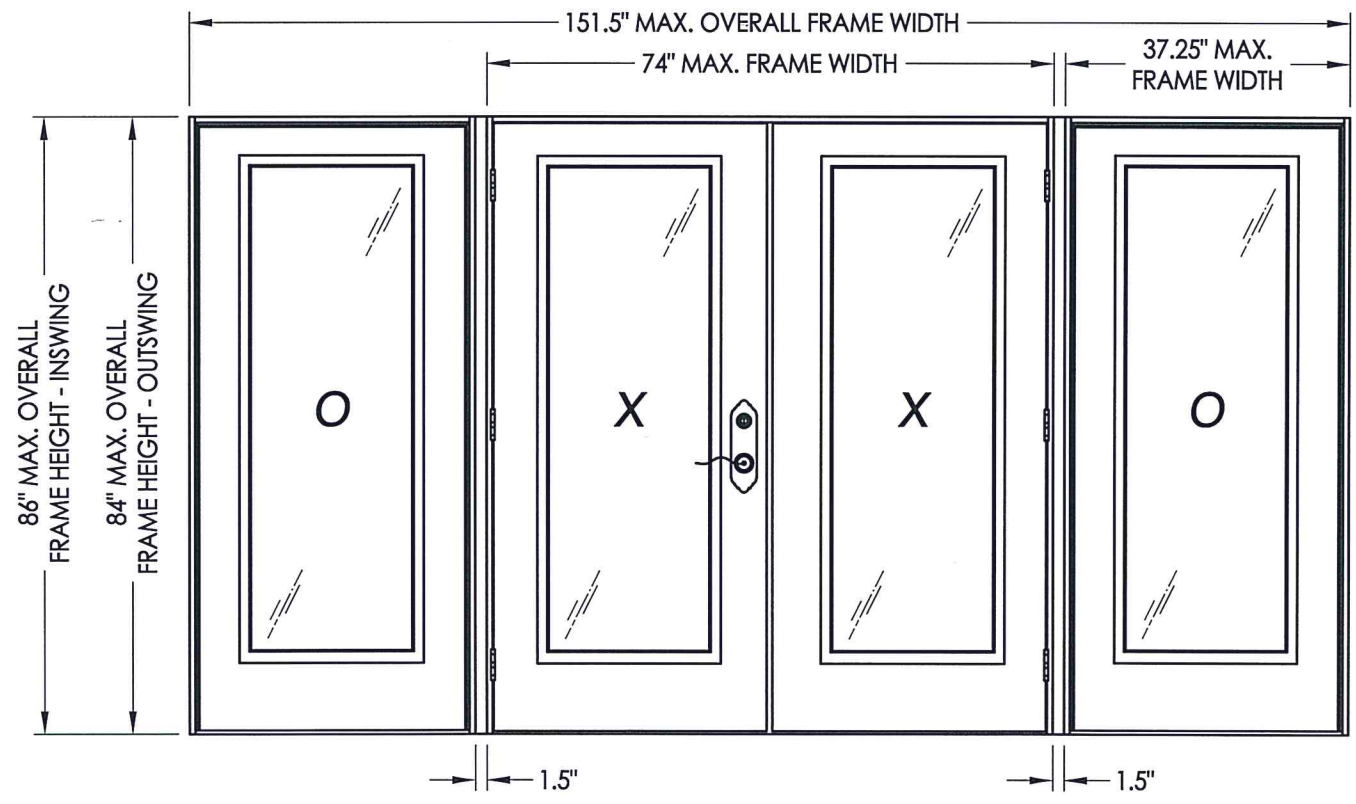
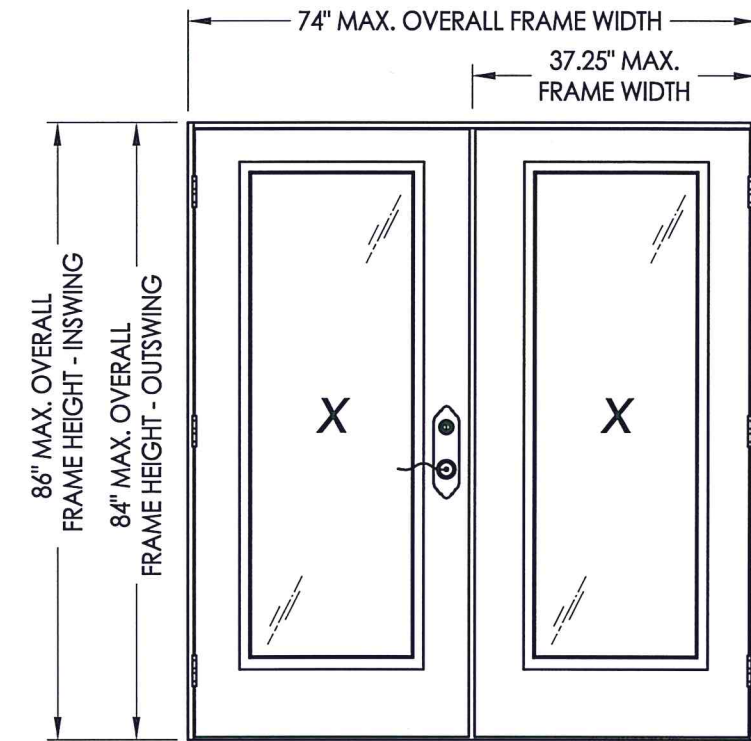

EVALUATED FOR USE IN THE STATE OF TEXAS

The Fiberglass Door system described herein complies with the 2018 International Residential Code (IRC), Sections R301 & R609 and the 2018 International Building Code (IBC), Sections 1404.13, 1609, 1709.5, 2403 and 2404 subject to the following conditions:

1. Anchors shall be as listed and spaced as shown in the details. Anchor embedment to base material shall be beyond wall dressing or stucco.
2. This system has been tested and evaluated as a large missile impact protective system for installation in areas that require wind borne debris protection. This product meets missile level "D" as defined in ASTM E 1996.
3. Allowable design pressure requirements must be equal to or less than the design pressure rating shown in the design pressure chart, sheet 1 of this drawing.
4. Conditions not covered by this drawing are subject to further engineering analysis.

TABLE OF CONTENTS

SHEET#	DESCRIPTION
1	Typical elevations, design pressures & general notes
2	Door panel & glazing details
3	Sidelite panel & glazing details
4	Elevations
5	Horizontal cross sections
6	Vertical cross sections
7	Vertical cross sections
8	Frame anchoring
9	Frame anchoring
10	Astragal & multi-point lock details
11	Lite frame & glazing details
12	Bill of materials and components

CONFIGURATION	MAX. FRAME DIMENSION	MAX. D.L.O. DIMENSION	GLASS TYPE	DESIGN PRESSURE (PSF) INSWING		DESIGN PRESSURE (PSF) OUTSWING	
				POSITIVE	NEGATIVE	POSITIVE	NEGATIVE
XX	74.0" x 86.0"	20.63" x 62.63"	G1	+50.0	-55.0	+50.0	-50.0
OXXO	151.5" x 86.0"	20.63" x 62.63"		+50.0	-55.0	+50.0	-50.0

PRODUCT: PLASTPRO FIBERGLASS DOOR
PART OR ASSEMBLY: TYPICAL ELEVATION, DESIGN PRESSURES & GENERAL NOTES

NO.	DATE	REVISIONS
1	9/21/22	UPDATE TO 2018 IBC/IRC CODE AND REVISE IMPACT LITE FRAME

DATE: 04/13/10
SCALE: N.T.S.
DWG. BY: JK
CHK. BY: LFS
DRAWING NO.: TX-4069
SHEET 1 OF 12

Z:\Clients\Plastpro, Inc PERMANENT\B - TD\DR 440 Glazed Fiberglass (Impact)\C - Drawings\TX-4068-69.dwg

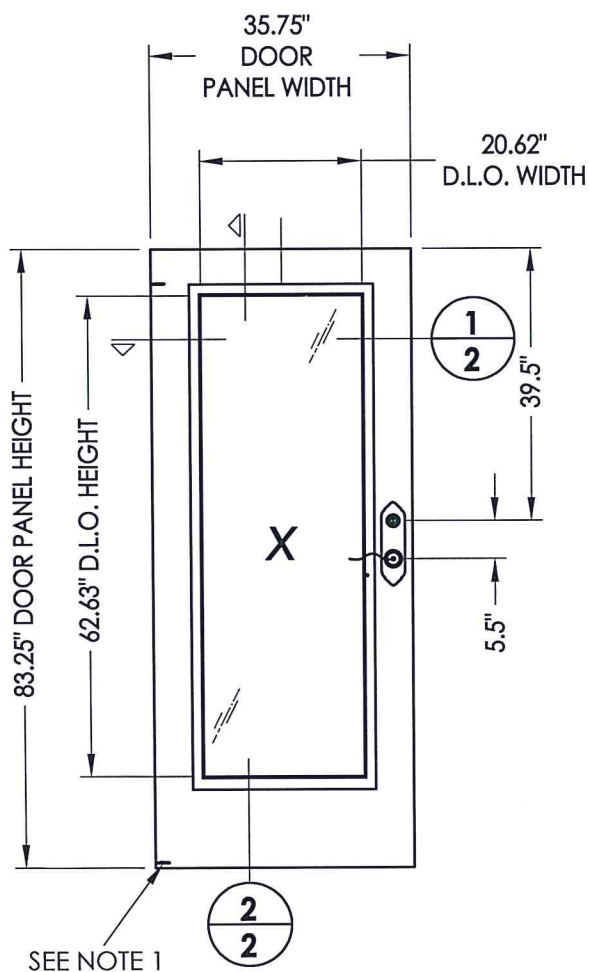
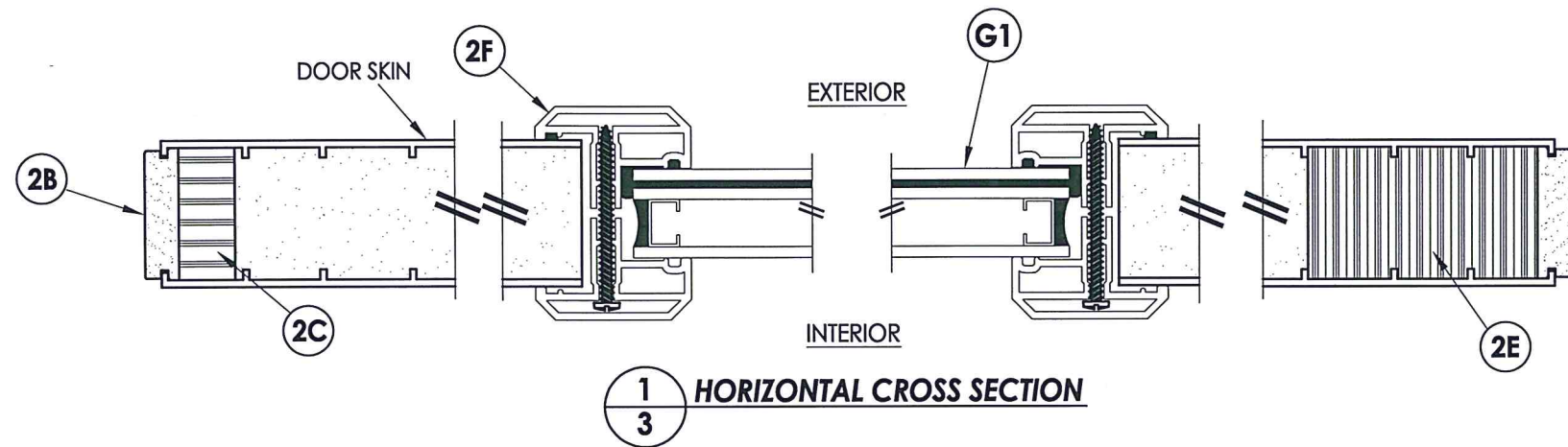

40 DOOR PANEL

NOTE:
1. #8 x 2" PFH wood screw through hinge cap into top and bottom rails for D.P. > 47 PSF.

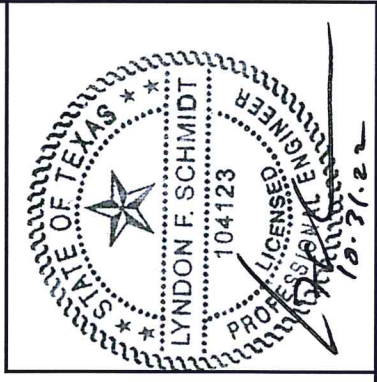
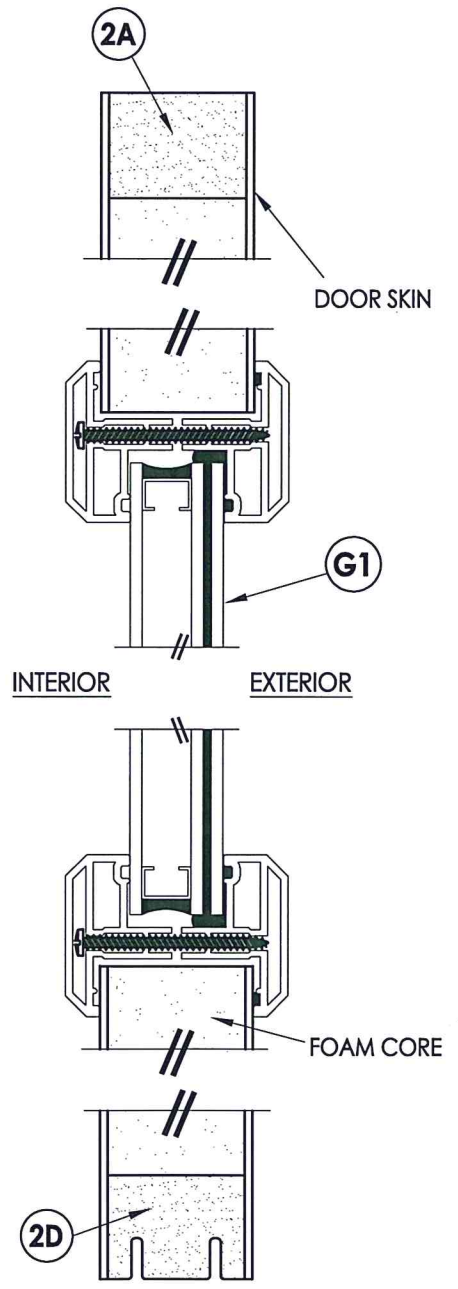
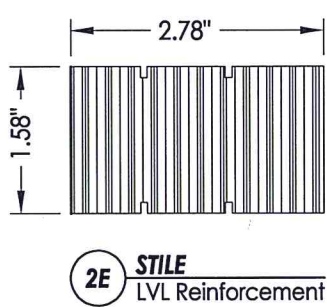
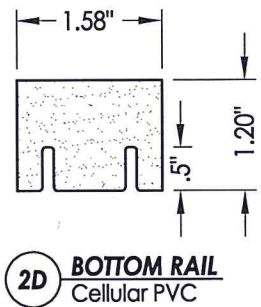
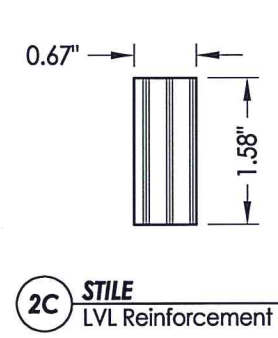
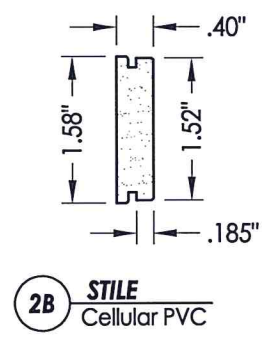
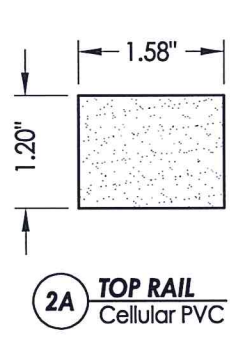

Documents Prepared By: Lyndon F. Schmidt, P.E.
TEXAS P.E. #104123

RW BUILDING CONSULTANTS, INC.
P.O. Box 230 Valrico FL, 33595
Phone No.: 813.659.9197

TEXAS BOARD OF PROFESSIONAL ENGINEERS
CERTIFICATE OF REGISTRATION # F-11852

PRODUCT: PLASTPRO FIBERGLASS DOOR
PART OR ASSEMBLY: DOOR PANEL DETAILS

NO.	DATE	BY
1	9/21/22	LFS
UPDATE TO 2018 IBC/IRC CODE AND REVISE IMPACT LITE FRAME		

DATE: 10/08/09
SCALE: N.T.S.
DWG. BY: JK
CHK. BY: LFS
DRAWING NO.: TX-4069
SHEET 2 OF 12

Z:\Clients\Plastpro, Inc PERMANENT\B - TD\DR 440 Glazed Fiberglass (Impact)\C - Drawings\TX-4068-69.dwg

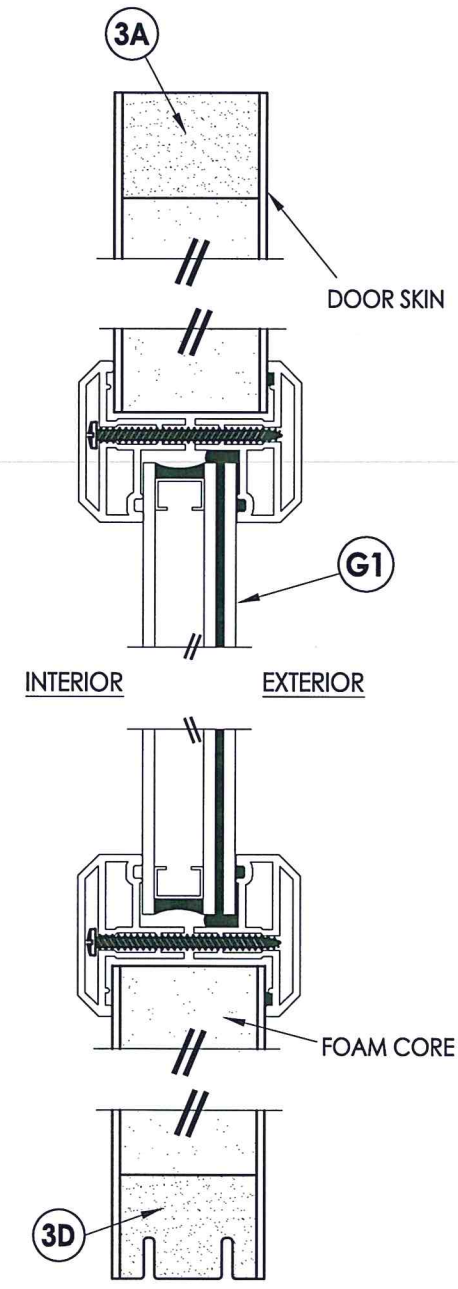
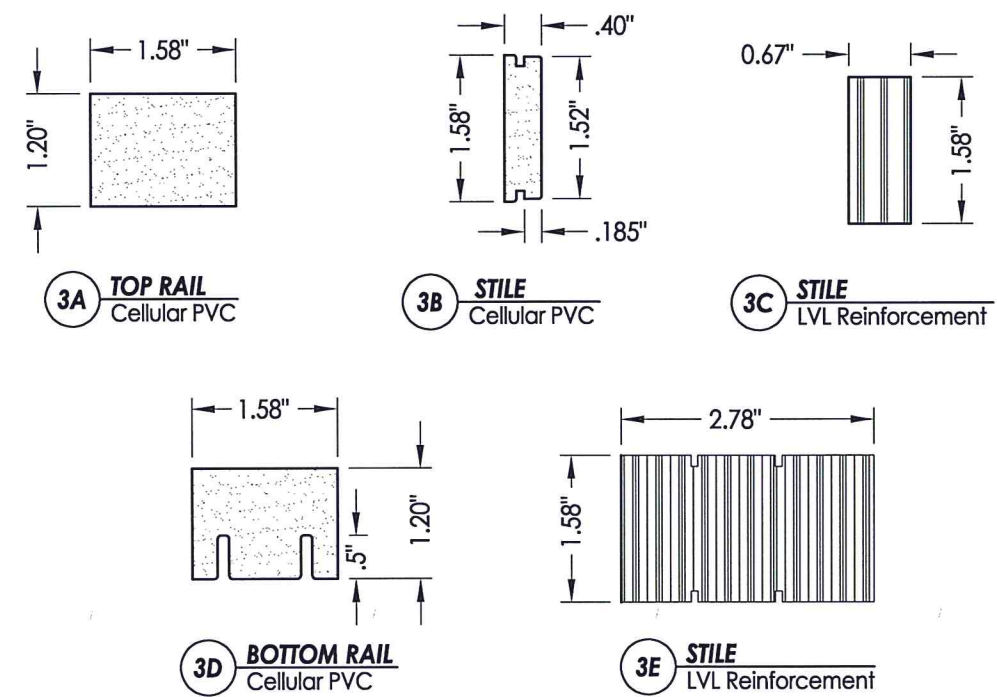
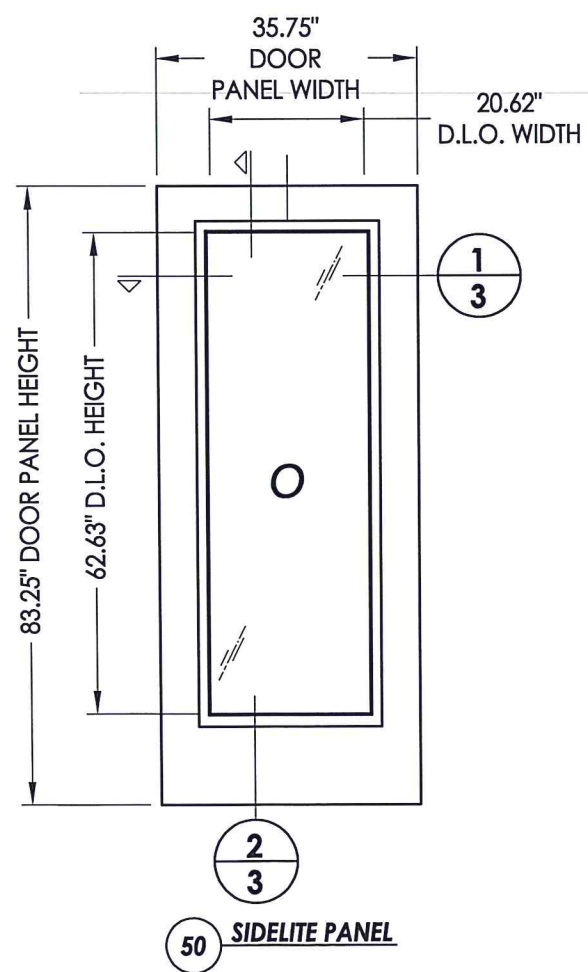
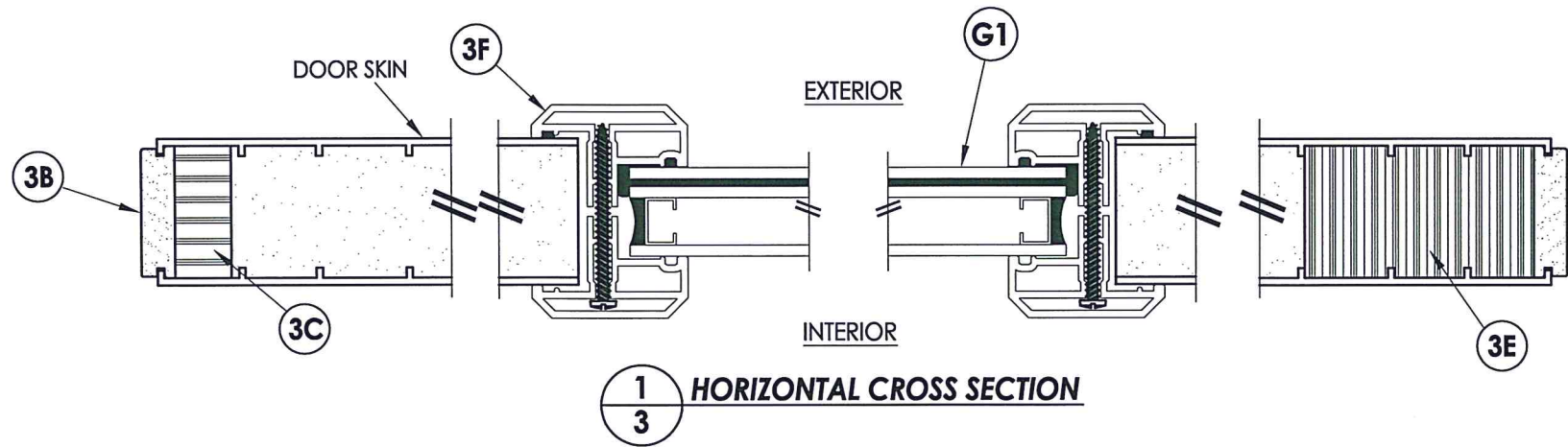

Documents Prepared By: Lyndon F. Schmidt, P.E.
TEXAS P.E. #104123

RW BUILDING CONSULTANTS, INC.
P.O. Box 230 Valrico FL, 33595
Phone No.: 813.659.9197

TEXAS BOARD OF PROFESSIONAL ENGINEERS
CERTIFICATE OF REGISTRATION # F-11852

PRODUCT:		PLASTPRO FIBERGLASS DOOR	
PART OR ASSEMBLY:		SIDELITE PANEL & GLAZING DETAILS	
NO.	DATE	BY	REVISIONS
1	9/21/22	LFS	UPDATE TO 2018 IBC/IRC CODE AND REVISE IMPACT LITE FRAME
DATE: 04/13/10			
SCALE: N.T.S.			
DWG. BY: JK			
CHK. BY: LFS			
DRAWING NO.: TX-4069			
SHEET 3 of 12			

FIBERGLASS DOOR SKIN: MIN. 0.075" THK.
CORE MATERIAL: POLYURETHANE FOAM (MIN. 1.9 PCF DENSITY)

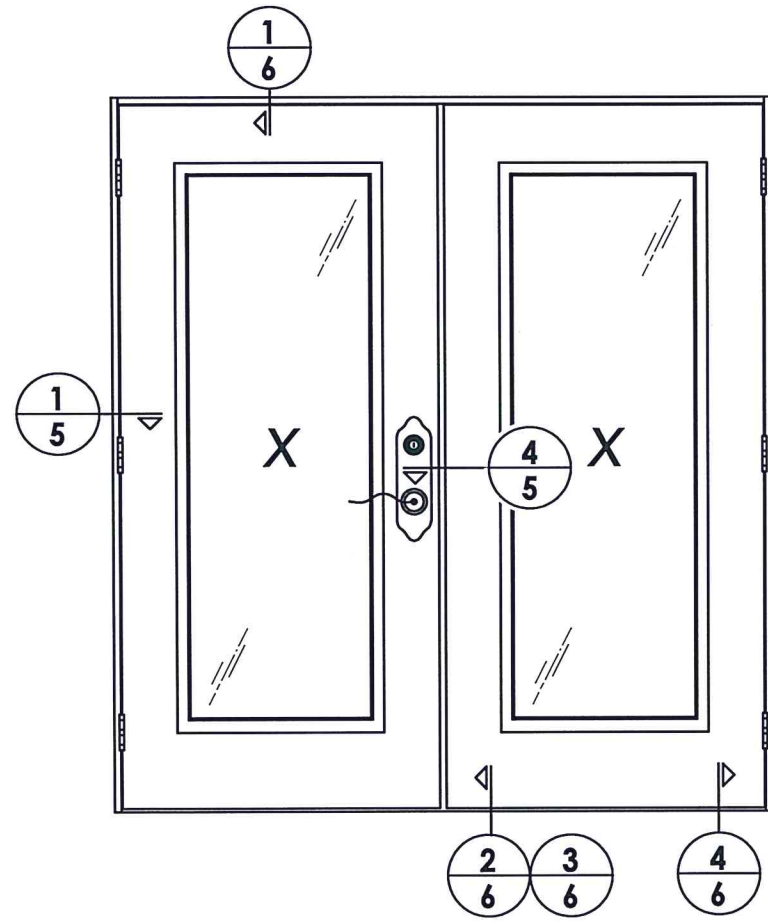

ELEVATION (XX)

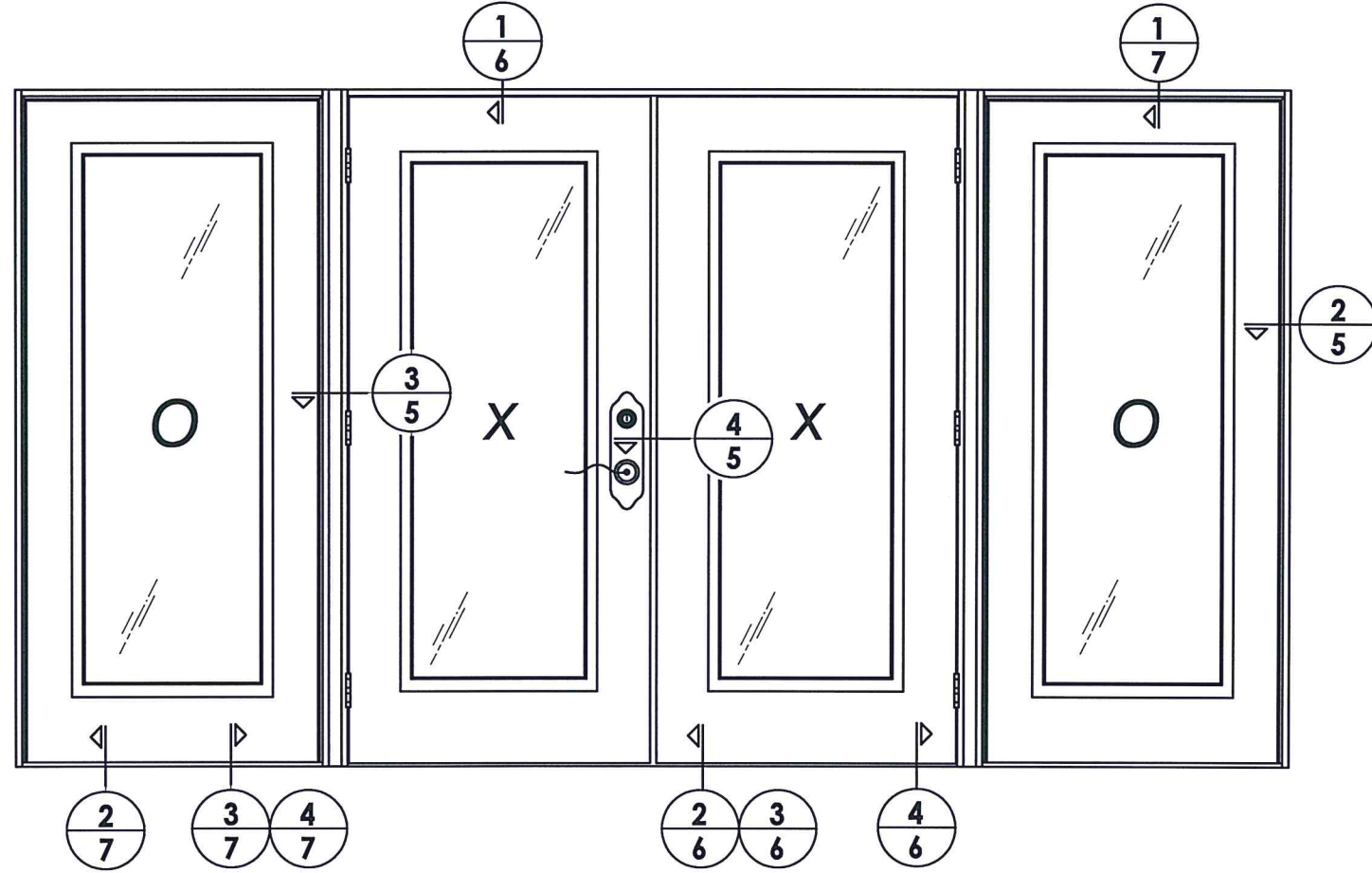

ELEVATION (OXXO)

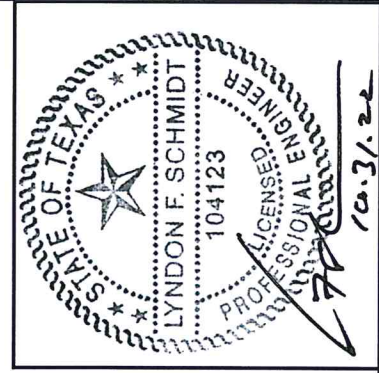

Documents Prepared By: Lyndon F. Schmidt, P.E.
TEXAS P.E. #104123

RW BUILDING CONSULTANTS, INC.
P.O. Box 230 Valrico FL 33595
Phone No.: 813.659.9197

TEXAS BOARD OF PROFESSIONAL ENGINEERS
CERTIFICATE OF REGISTRATION # F-11852

PRODUCT:		PLASTPRO FIBERGLASS DOOR	
PART OR ASSEMBLY:		ELEVATIONS	
NO.	DATE	REVISIONS	BY
1	9/21/22	UPDATE TO 2018 IBC/IRC CODE AND REVISE IMPACT LITE FRAME	LFS

DATE: 04/13/10

SCALE: N.T.S.

DWG. BY: JK

CHK. BY: LFS

DRAWING NO.:

TX-4069

SHEET 4 OF 12

Z:\Clients\Plastpro, Inc PERMANENT\B - TD\DR 440 Glazed Fiberglass (Impact)\C - Drawings\TX-4068-69.dwg

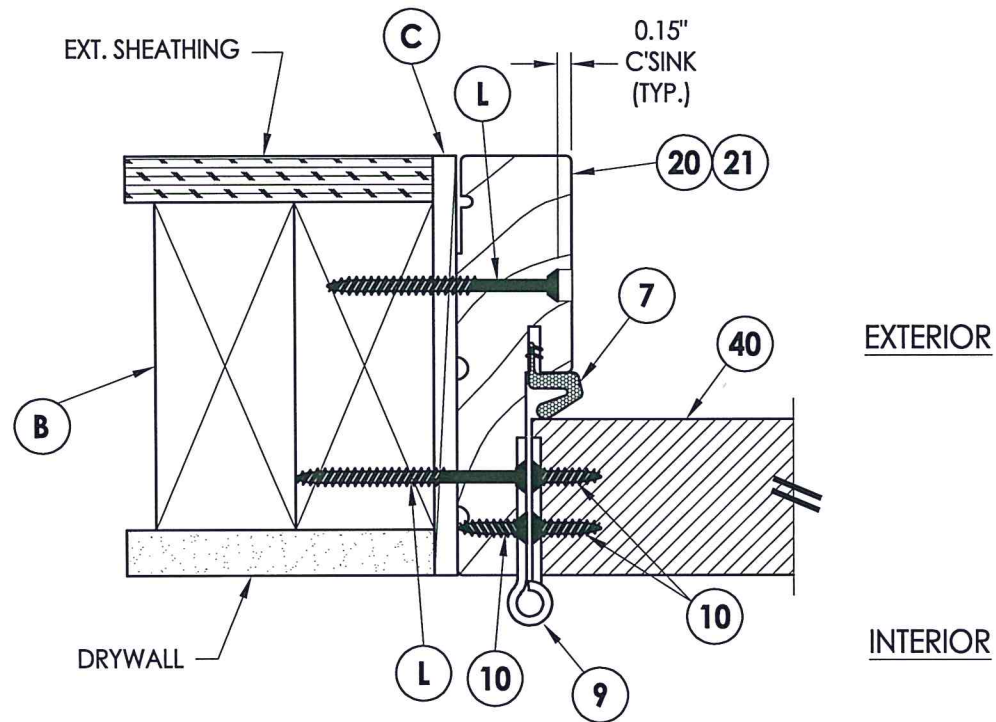

1 HORIZONTAL CROSS SECTION
5 Inswing shown - outswing also approved

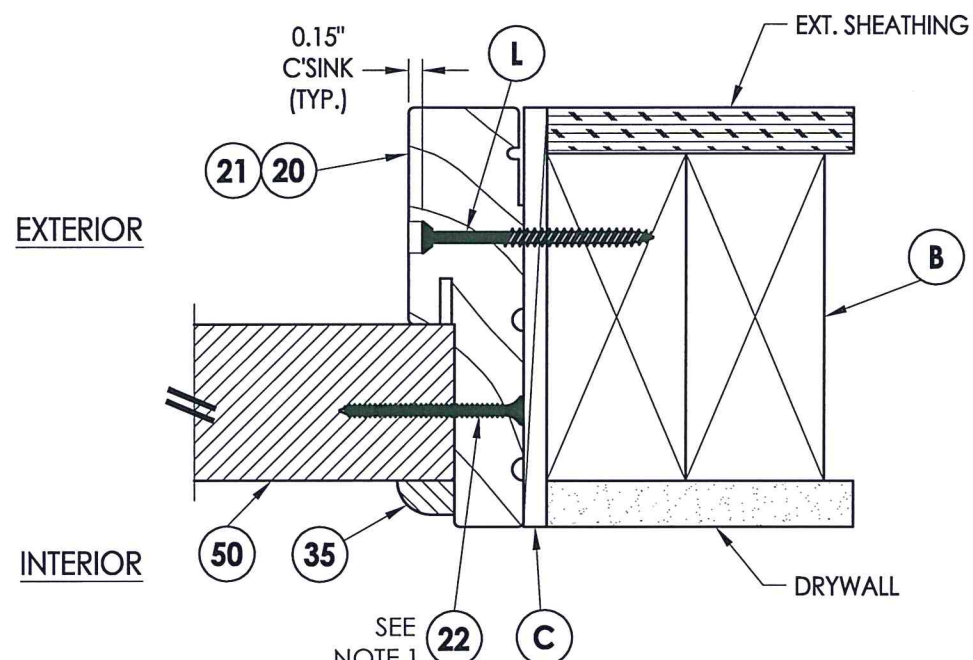

2 HORIZONTAL CROSS SECTION
5 Inswing shown - outswing also approved

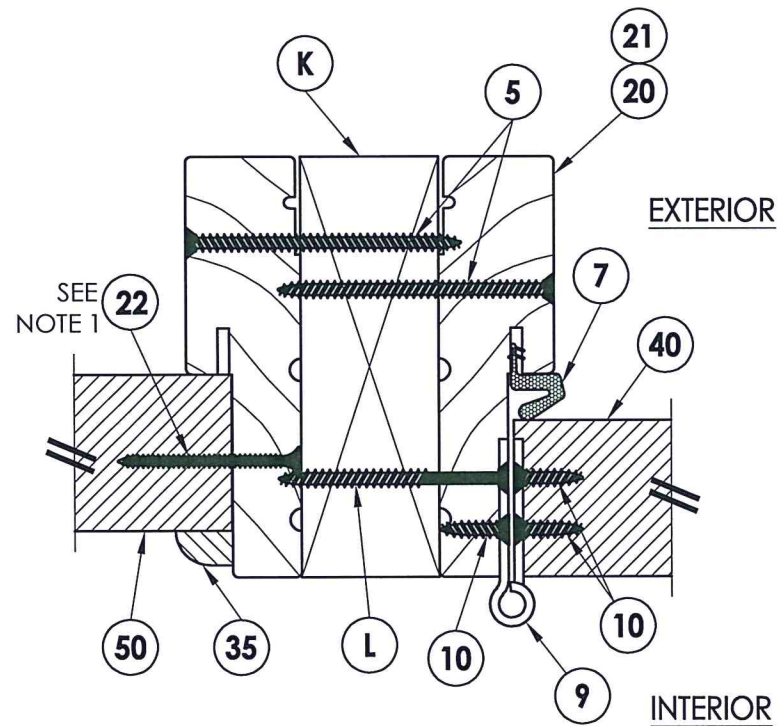

3 HORIZONTAL CROSS SECTION
5 Inswing shown - outswing also approved

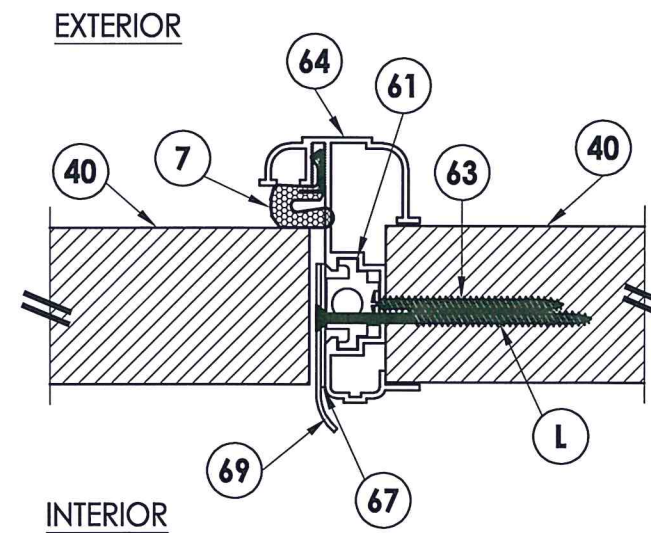

4 HORIZONTAL CROSS SECTION
5 Inswing shown - outswing also approved

NOTE:

1. Sidelite screws (item #22) located at 3", 6", 16", 27", 38", 49", 60", 70" and 80" from bottom of panel.

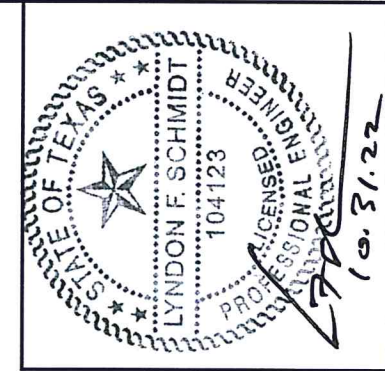

Documents Prepared By: Lyndon F. Schmidt, P.E.
 TEXAS P.E. #104123

RW BUILDING CONSULTANTS, INC.
 P.O. Box 230 Vairco FL 33595
 Phone No.: 813.659.9197
 TEXAS BOARD OF PROFESSIONAL ENGINEERS
 CERTIFICATE OF REGISTRATION # F-11852

PRODUCT: PLASTPRO FIBERGLASS DOOR		PART OR ASSEMBLY: HORIZONTAL CROSS SECTIONS	
LFS	BY	NO.	DATE
1	9/21/22	1	9/21/22
UPDATE TO 2018 IBC/IRC CODE AND REVISE IMPACT LITE FRAME			
REVISIONS			
DATE: 04/13/10			
SCALE: N.T.S.			
DWG. BY: JK			
CHK. BY: LFS			
DRAWING NO.: TX-4069			
SHEET 5 OF 12			

Z:\Clients\Plastpro, Inc PERMANENT\B - TD\DR 440 Glazed Fiberglass (Impact)\C - Drawings\TX-4068-69.dwg

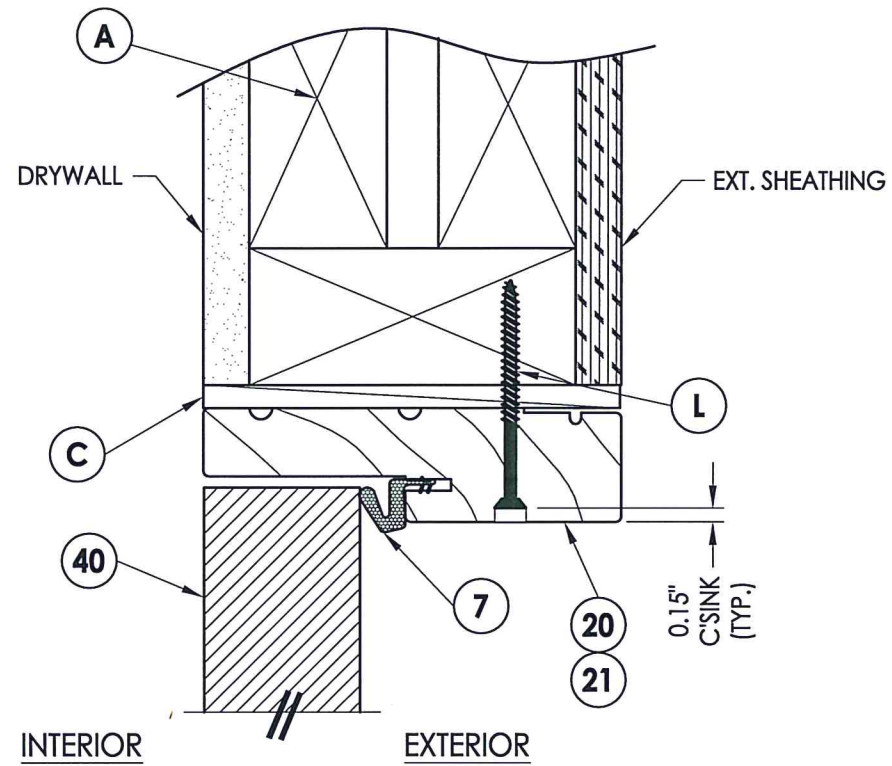

1 VERTICAL CROSS SECTION
6 Inswing shown - outswing also approved

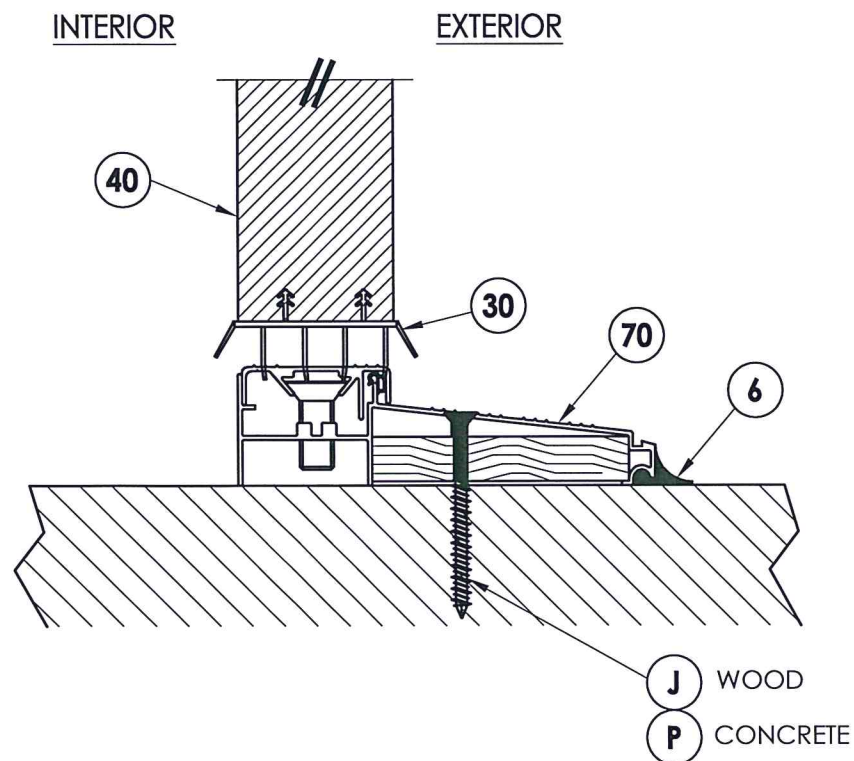

2 VERTICAL CROSS SECTION
6 Inswing configuration

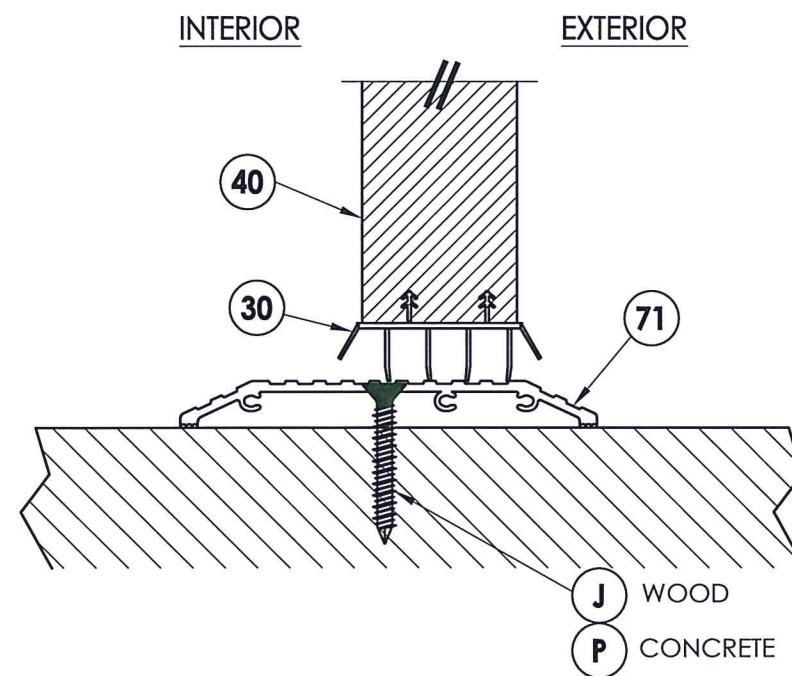

3 VERTICAL CROSS SECTION
6 Shown w/ ADA threshold

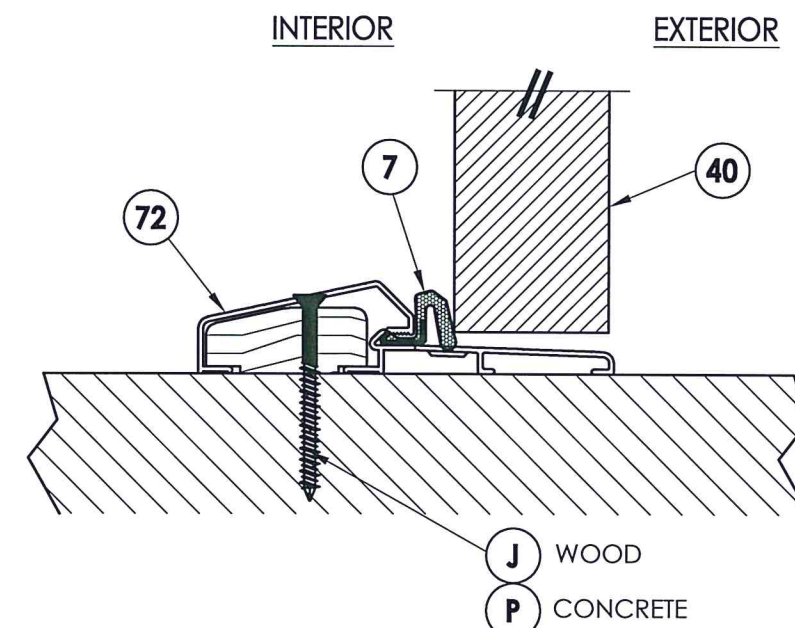

4 VERTICAL CROSS SECTION
6 Outswing configuration

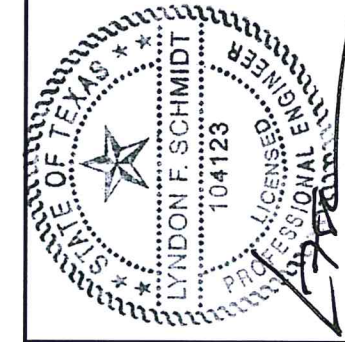

Documents Prepared By: Lyndon F. Schmidt, P.E.
 TEXAS P.E. #104123

RW BUILDING CONSULTANTS, INC.
 P.O. Box 230 Valrico FL 33595
 Phone No.: 813.659.9197
 TEXAS BOARD OF PROFESSIONAL ENGINEERS
 CERTIFICATE OF REGISTRATION # F-11852

PRODUCT:		PLASTPRO FIBERGLASS DOOR	
PART OR ASSEMBLY:		VERTICAL CROSS SECTIONS	
NO.	DATE	LFS	BY
1	9/21/22	UPDATE TO 2018 IBC/IRC CODE AND REVISE IMPACT LITE FRAME	
REVISIONS			
DATE: 04/13/10			
SCALE: N.T.S.			
DWG. BY: JK			
CHK. BY: LFS			
DRAWING NO.: TX-4069			
SHEET 6 OF 12			

Z:\Clients\Plastpro, Inc PERMANENT\B - TD\DR 440 Glazed Fiberglass (Impact)\C - Drawings\TX-4068-69.dwg

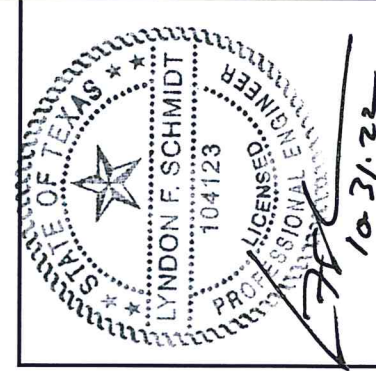

Documents Prepared By: Lyndon F. Schmidt, P.E.
TEXAS P.E. #104123

RW BUILDING CONSULTANTS, INC.
P.O. Box 230 Valrico FL, 33595
Phone No.: 813.659.9197

TEXAS BOARD OF PROFESSIONAL ENGINEERS
CERTIFICATE OF REGISTRATION # F-11852

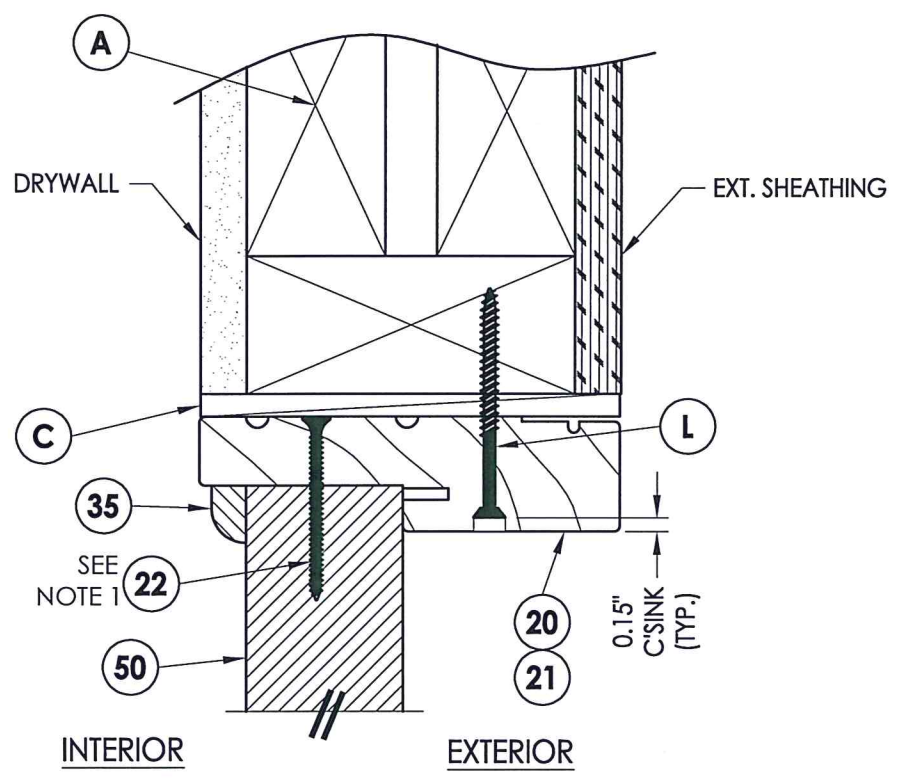

1 VERTICAL CROSS SECTION
7 Inswing shown - outswing also approved

NOTE:
1. Screws thru head and sill jamb located 3" from each end and on center line.

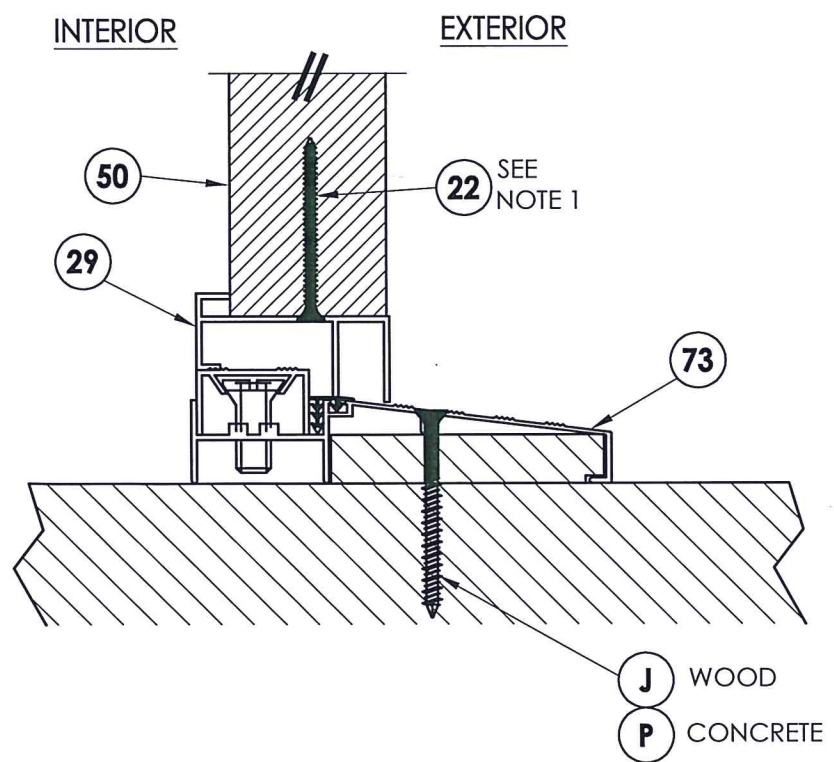

2 VERTICAL CROSS SECTION
7 Inswing configuration

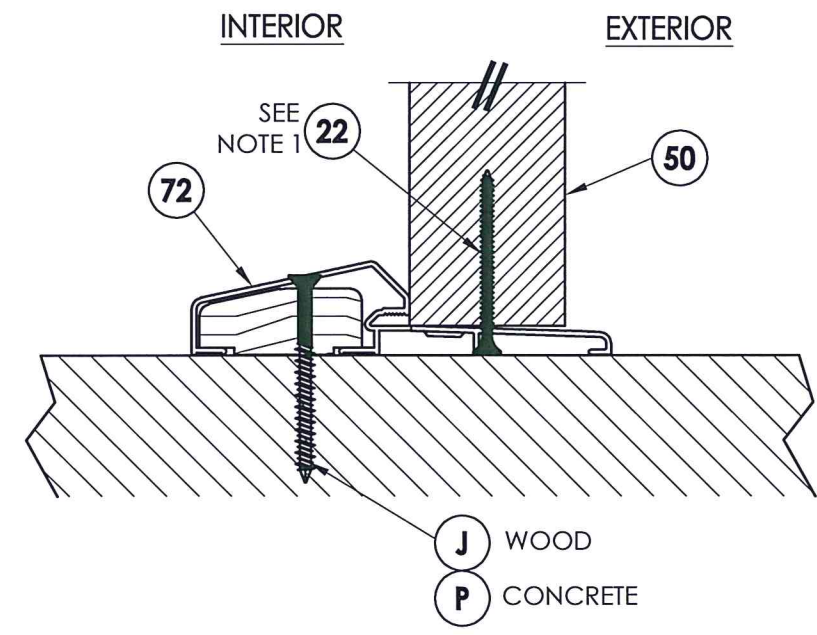

3 VERTICAL CROSS SECTION
7 Outswing configuration

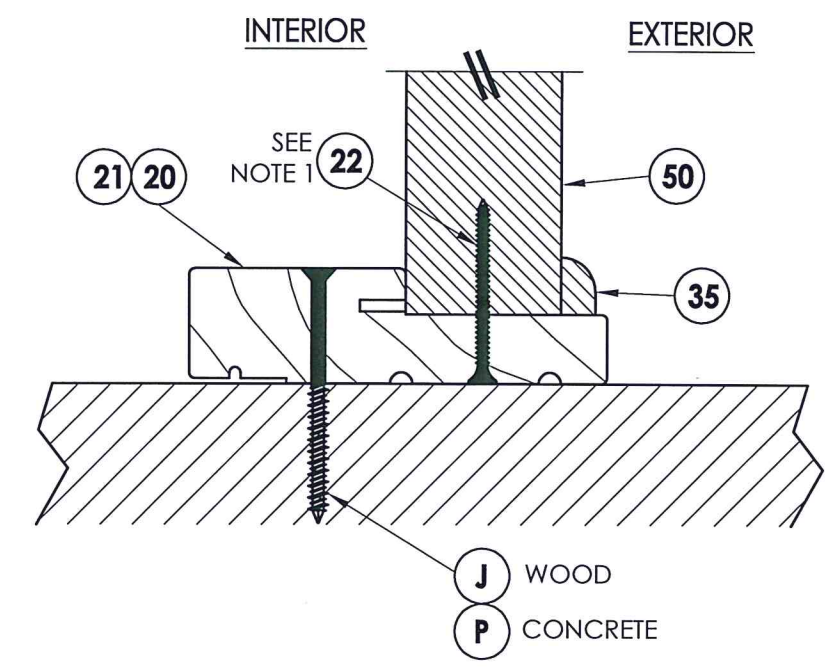

4 VERTICAL CROSS SECTION
7 Outswing configuration

PRODUCT:		PLASTPRO FIBERGLASS DOOR	
PART OR ASSEMBLY:		VERTICAL CROSS SECTIONS	
NO.	DATE	BY	REVISIONS
1	9/21/22	LFS	UPDATE TO 2018 IBC/IRC CODE AND REVISE IMPACT LITE FRAME
DATE: 04/13/10			
SCALE: N.T.S.			
DWG. BY: JK			
CHK. BY: LFS			
DRAWING NO.: TX-4069			
SHEET 7 OF 12			

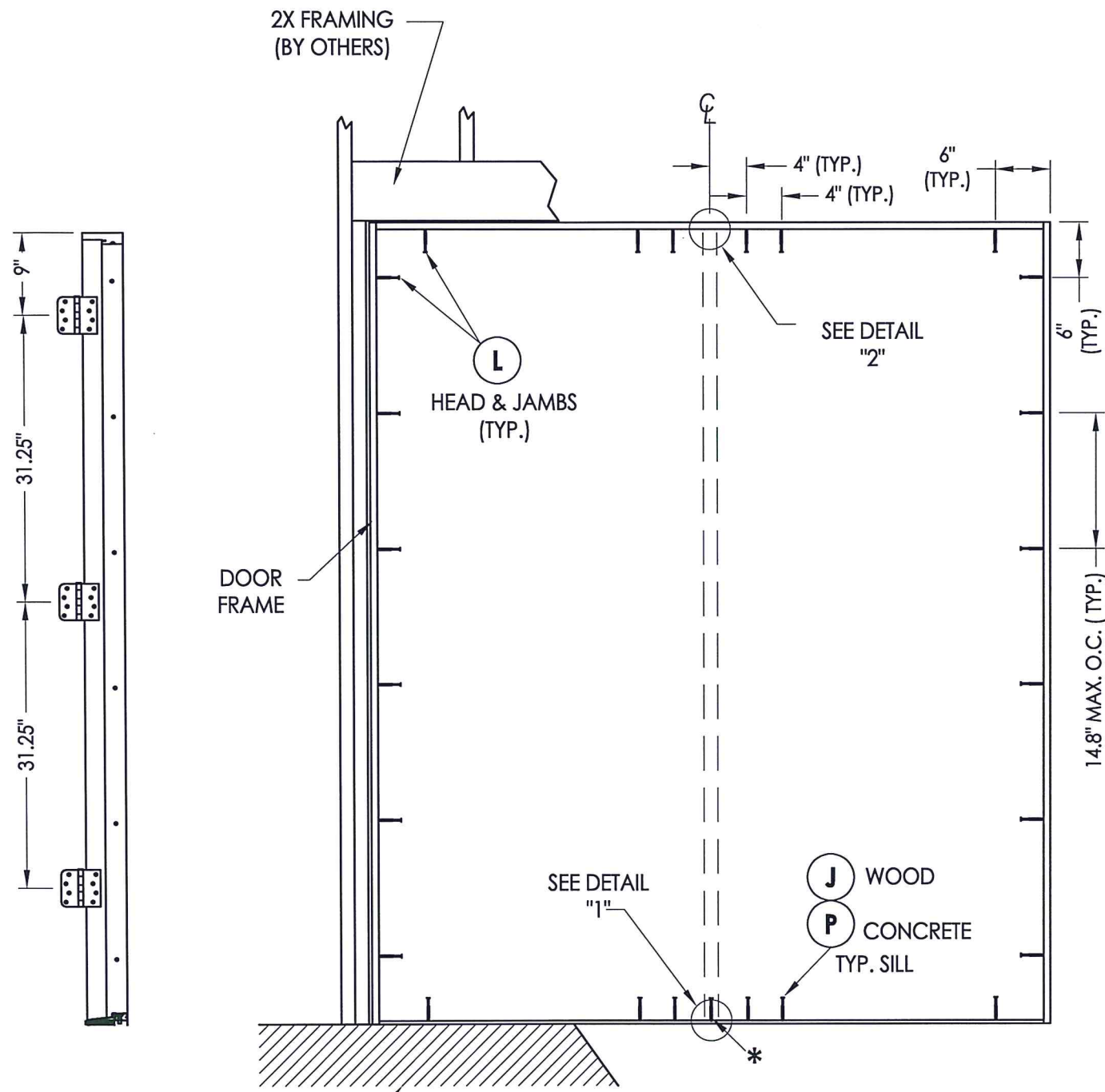

HINGE JAMB

FRAME ANCHORING
XX

ASTRAGAL

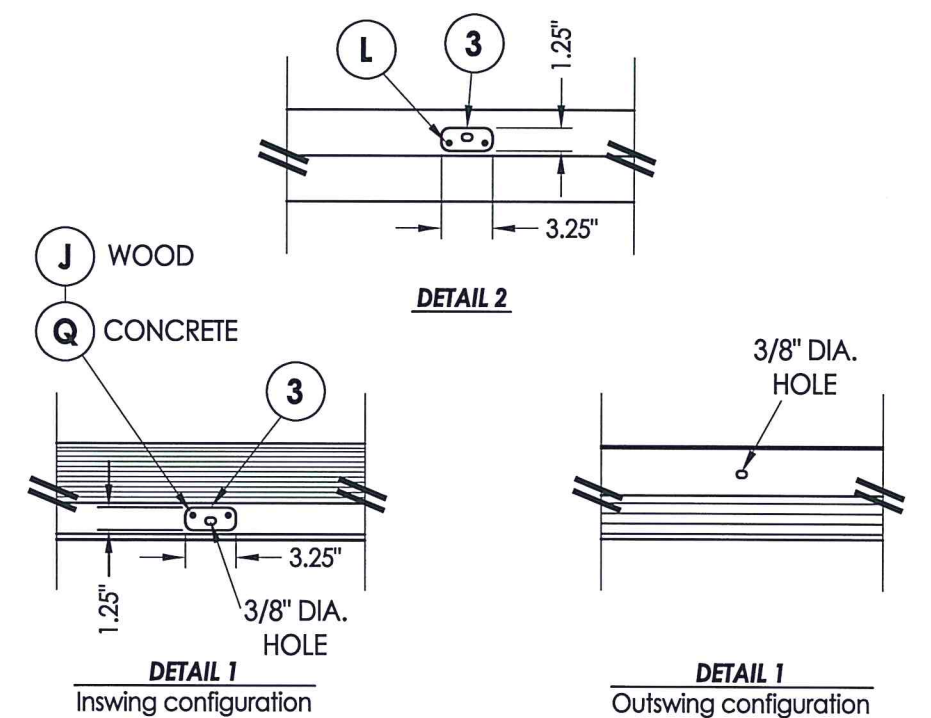
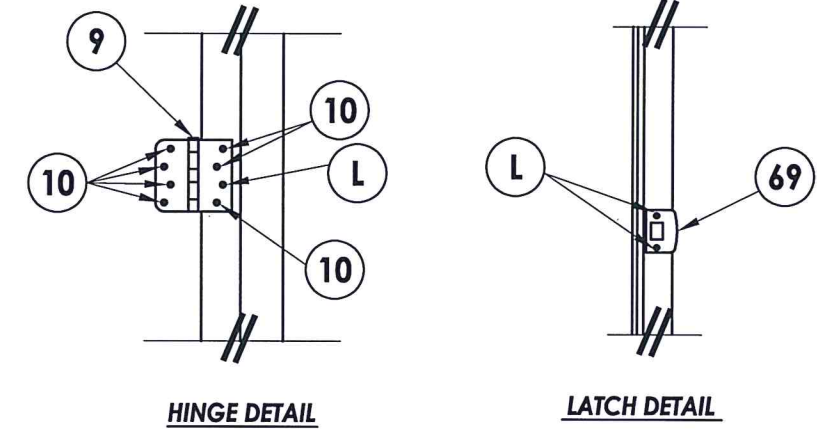

* ADDITIONAL ANCHOR REQ'D
FOR D.P. > 40 PSF
(WOOD SUBSTRATE ONLY)

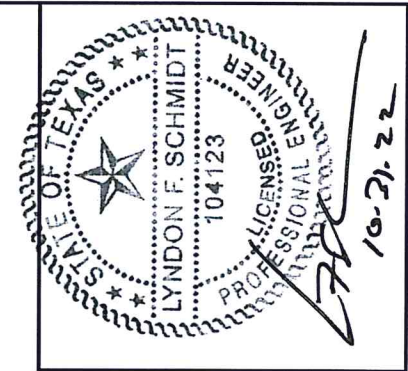

Documents Prepared By: Lyndon F. Schmidt, P.E.
TEXAS P.E. #104123

RW BUILDING CONSULTANTS, INC.
P.O. Box 230 Valrico FL 33595
Phone No.: 813.659.9197

TEXAS BOARD OF PROFESSIONAL ENGINEERS
CERTIFICATE OF REGISTRATION # F-11852

PRODUCT:		PLASTPRO FIBERGLASS DOOR	
PART OR ASSEMBLY:		FRAME ANCHORING	
NO.	DATE	BY	REVISIONS
1	9/21/22	LFS	UPDATE TO 2018 IBC/IRC CODE AND REVISE IMPACT LITE FRAME

DATE: 04/13/10
SCALE: N.T.S.
DWG. BY: JK
CHK. BY: LFS
DRAWING NO.: TX-4069
SHEET 8 OF 12

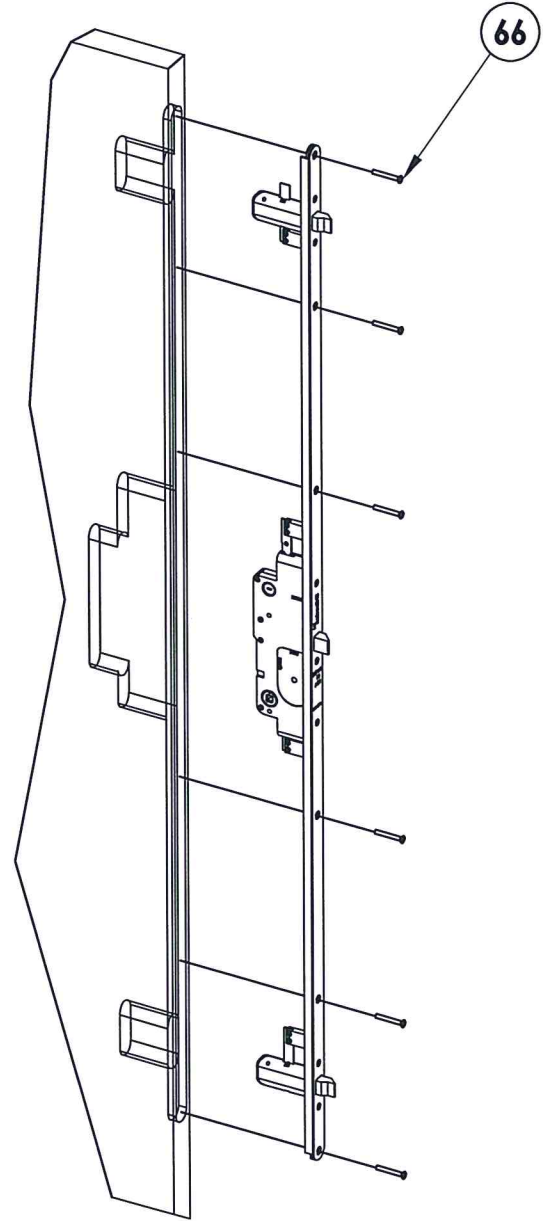

65 MULTI-POINT LOCK
Trilennium by W & F

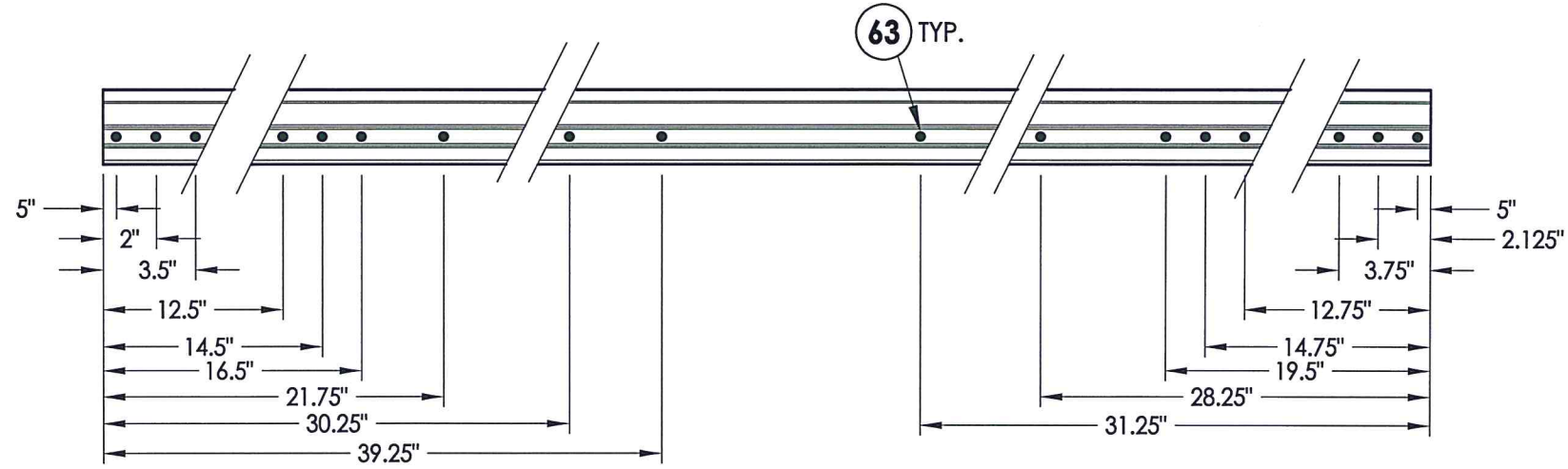

ASTRAGAL SCREW LOCATIONS

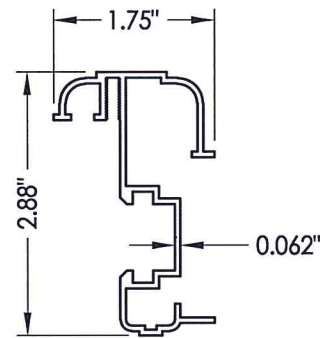

64 ASTRAGAL
By DLP

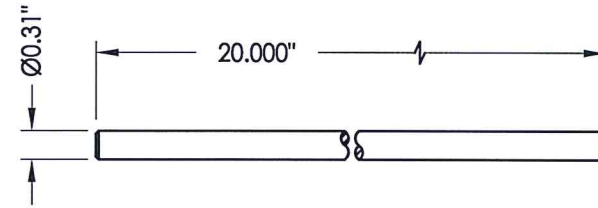

62 SLIDE BOLT ROD
Typ. top & bottom of astragal
top through 2.0"
bottom through 2.0"

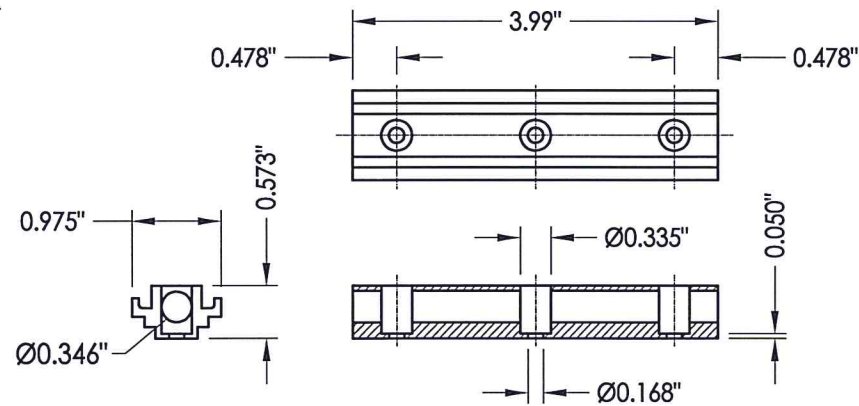

61 CONCEALED STIFFENER

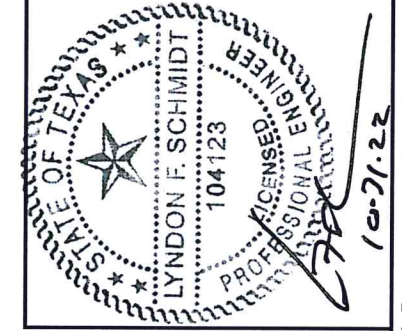

Documents Prepared By: Lyndon F. Schmidt, P.E.
TEXAS P.E. #104123

RW BUILDING CONSULTANTS, INC.
P.O. Box 230 Vairico FL 33595
Phone No.: 813.659.9197
TEXAS BOARD OF PROFESSIONAL ENGINEERS
CERTIFICATE OF REGISTRATION # F-11852

PRODUCT:		PLASTPRO FIBERGLASS DOOR	
PART OR ASSEMBLY:		ASTRAGAL & MULTI-POINT LOCK DETAILS	
NO.	DATE	REVISIONS	BY
1	9/21/22	UPDATE TO 2018 IBC/IRC CODE AND REVISE IMPACT LITE FRAME	LFS
DATE: 04/13/10		SCALE: N.T.S.	
DWG. BY: JK		CHK. BY: LFS	
DRAWING NO.: TX-4069		SHEET 10 OF 12	

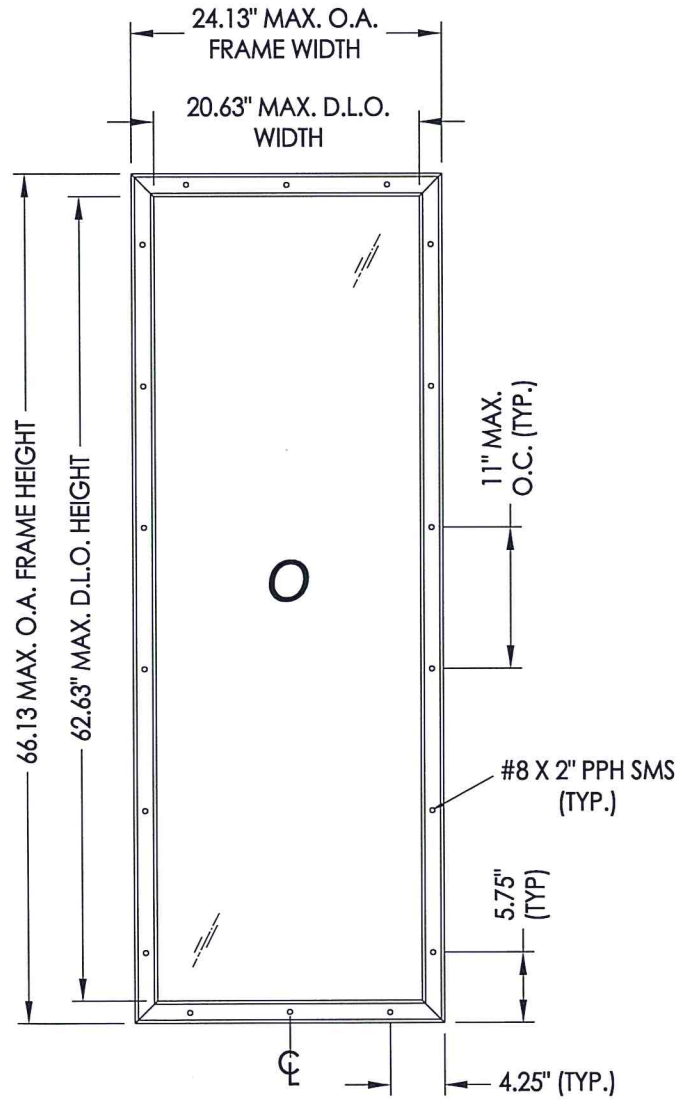

ODL LITE FRAME DETAIL
"FLAT FRAME" PROFILE

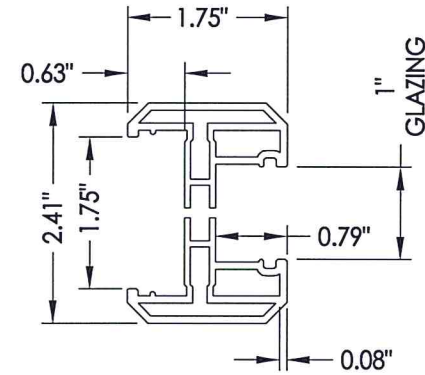
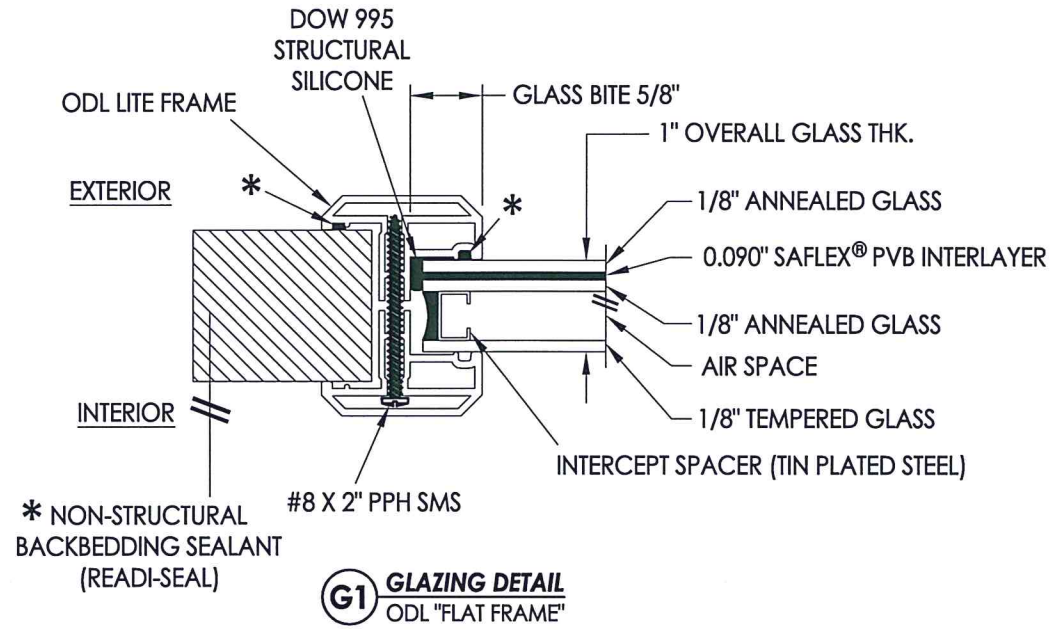

ODL LITE FRAME
"FLAT FRAME"
(6063-T5 ALUM)

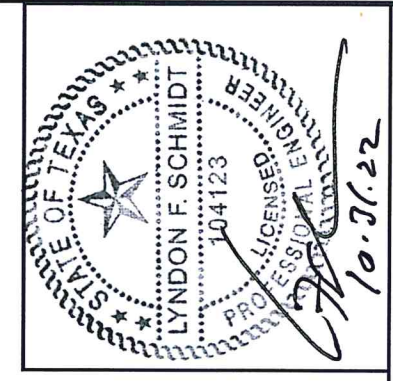

Documents Prepared By: Lyndon F. Schmidt, P.E.
TEXAS P.E. #104123

RW BUILDING CONSULTANTS, INC.
P.O. Box 230 Valrico FL 33595
Phone No.: 813.659.9197
TEXAS BOARD OF PROFESSIONAL ENGINEERS
CERTIFICATE OF REGISTRATION # F-11852

PRODUCT:		PLASTPRO FIBERGLASS DOOR	
PART OR ASSEMBLY:		LITE FRAME & GLAZING DETAILS	
NO.	DATE	DESCRIPTION	BY
1	9/21/22	UPDATE TO 2018 IBC/IRC CODE AND REVISE IMPACT LITE FRAME	LFS
REVISIONS			
DATE: 04/13/10			
SCALE: N.T.S.			
DWG. BY: JK			
CHK. BY: LFS			
DRAWING NO.: TX-4069			
SHEET 11 OF 12			

Z:\Clients\Plastpro, Inc.Permanent\B - TD\DR 440 Glazed Fiberglass (Impact)\C - Drawings\TX-4068-69.dwg

BILL OF MATERIALS

ITEM	DESCRIPTION	MATERIAL
A	2X HEADER FRAMING SG >= 0.42	WOOD
B	2X FRAMING SG >= 0.42	WOOD
C	1/4" MAX. SHIM SPACE	-
J	#10 X 3" PFH WOOD SCREW	STEEL
K	2X REINFORCEMENT (CLEAR PINE SG >= 0.42)	WOOD
L	#10 X 2-1/2" PFH WOOD SCREW (1.15" MIN. EMBEDMENT)	STEEL
M	#8 X 2-1/2" PFH WOOD SCREW	STEEL
P	1/4" PFH DeWALT OR ITW CONCRETE SCREW (1-3/4" MIN. EMB.)	STEEL
Q	3/16" PFH ITW CONCRETE SCREW (1-3/4" MIN. EMB.)	STEEL
3	ASTRAGAL STRIKE PLATE	STEEL
5	#10 X 3" PFH SCREW	STEEL
6	SEALANT	SILICONE
7	WEATHERSTRIP BY Q-LON	FOAM
9	4" HINGE	STEEL
10	#9 X 3/4" PFH WOOD SCREW	STEEL
20	JAMB FINGER - JOINT - PINE (SG >= 0.42)	WOOD
21	POLY FIBER JAMB	POLY FIBER
22	#7 X 2" PFH DRYWALL SCREW	STEEL
29	SIDELITE SPACER	PVC
30	DOOR SWEEP	ALUM.
35	TRIM	WOOD
40	DOOR PANEL - SEE DOOR PANEL DETAIL SHEET FOR CONSTRUCTION DETAILS	-
50	SIDELITE PANEL - SEE SIDELITE PANEL DETAIL SHEET FOR CONSTRUCTION DETAILS	-
61	CONCEALED STIFFENER 6063-T6 BY PLASTPRO	ALUMINUM
62	SLIDE BOLT ROD	STEEL
63	#8 X 2" PPH SMS	STEEL
64	ASTRAGAL 6063-T5 ALUMINUM BY DLP	ALUMINUM
65	MULTI-POINT LOCK ASSEMBLY TRILENNIUM BY W & F	-
66	#10 X 1-1/2" PFH SCREW	STEEL
67	BACKING PLATE	STEEL
69	MULTI-POINT STRIKE PLATE	STEEL
70	INSWING THRESHOLD BY DLP	ALUM. / WOOD
71	ADA THRESHOLD BY DLP	ALUM.
72	OUTSWING THRESHOLD BY DLP	ALUM. / WOOD
73	SIDELITE THRESHOLD BY DLP	ALUM. / WOOD

CONCRETE ANCHOR NOTES:

- Concrete anchor locations at the corners may be adjusted to maintain the min. edge distance to mortar joints.
- Concrete anchor locations noted as "MAX. ON CENTER" must be adjusted to maintain the min. edge distance to mortar joints, additional concrete anchors may be required to ensure the "MAX. ON CENTER" dimension are not exceeded.
- Concrete anchor table:

ANCHOR TYPE	ANCHOR SIZE	MIN. EMBEDMENT	MIN. CLEARANCE TO MASONRY EDGE	MIN. CLEARANCE TO ADJACENT ANCHOR
ITW TAPCON®	1/4"	1-3/4"	2"	4"
DeWALT ULTRACON®	1/4"	1-3/4"	1"	4"
ITW TAPCON®	3/16"	1-3/4"	2-5/8"	2-1/4"

WOOD SCREW INSTALLATION NOTES:

- Maintain a minimum 5/8" edge distance, 1" end distance, & 1" o.c. spacing of wood screws to prevent the splitting of wood.

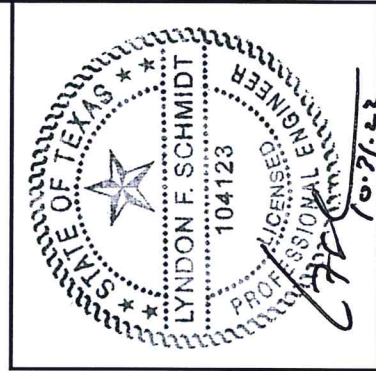
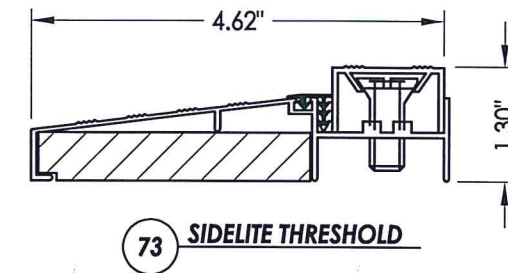
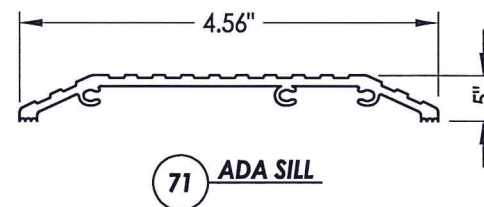
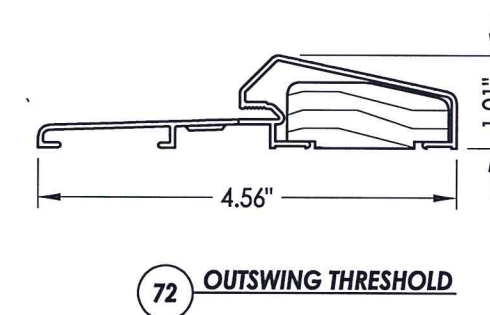
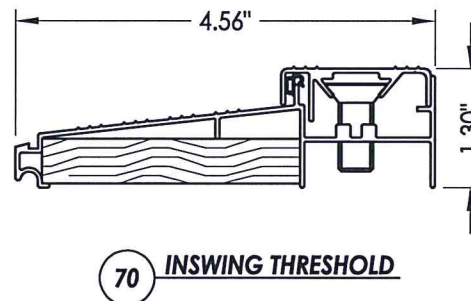
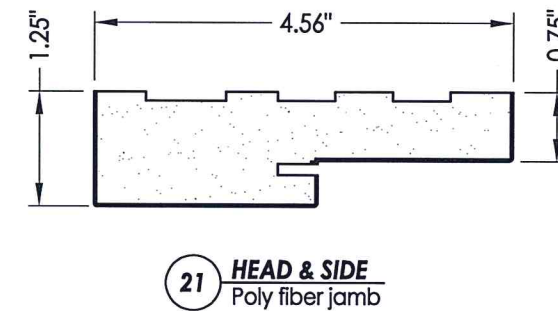
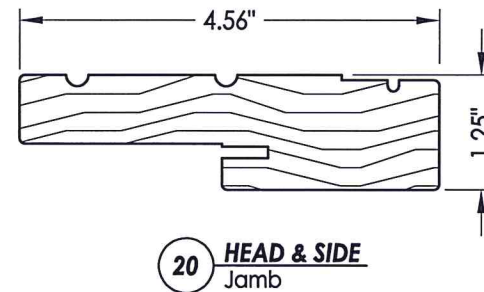
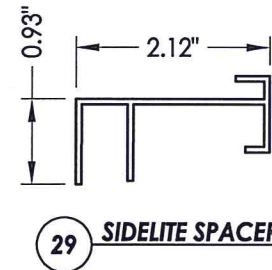

Documents Prepared By: Lyndon F. Schmidt, P.E.
TEXAS P.E. #104123

R.W. BUILDING CONSULTANTS, INC.
P.O. Box 230 Valrico FL 33595
Phone No.: 813.659.9197
TEXAS BOARD OF PROFESSIONAL ENGINEERS
CERTIFICATE OF REGISTRATION # F-11852

PRODUCT:	PLASTPRO FIBERGLASS DOOR
PART OR ASSEMBLY:	BILL OF MATERIALS & COMPONENTS
DATE:	04/13/10
SCALE:	N.T.S.
DWG. BY:	JK
CHK. BY:	LFS
DRAWING NO.:	TX-4069
SHEET	12 OF 12