

MODEL 0509
HORIZONTAL SLIDER
"NON-IMPACT"

EVALUATED FOR USE IN THE STATE OF TEXAS

TDI WIN-94

The Horizontal Slider Window described herein complies with the 2018 International Residential Code (IRC), Sections R301 & R609 and the 2018 International Building Code (IBC), Sections 1404.13, 1609, 1709.5, 2403 and 2404 subject to the following conditions:

1. Anchors shall be as listed and spaced as shown in the details. Anchor embedment to base material shall be beyond wall dressing or stucco.
2. When used in areas requiring wind-borne debris protection this product is required to be protected with an impact resistant covering that complies with Section R301.2.1.2 of the IRC and Section 1609.2 of the IBC.
3. Allowable design pressure requirements must be equal to or less than the design pressure rating shown in the design pressure chart, sheet 1 of this drawing.
4. Conditions not covered by this drawing are subject to further engineering analysis.

TABLE OF CONTENTS	
SHEET#	DESCRIPTION
1	Typical elevations, design pressures & general notes
2	Vertical & horizontal cross sections & frame anchoring
3	Bill of materials, glazing detail and components

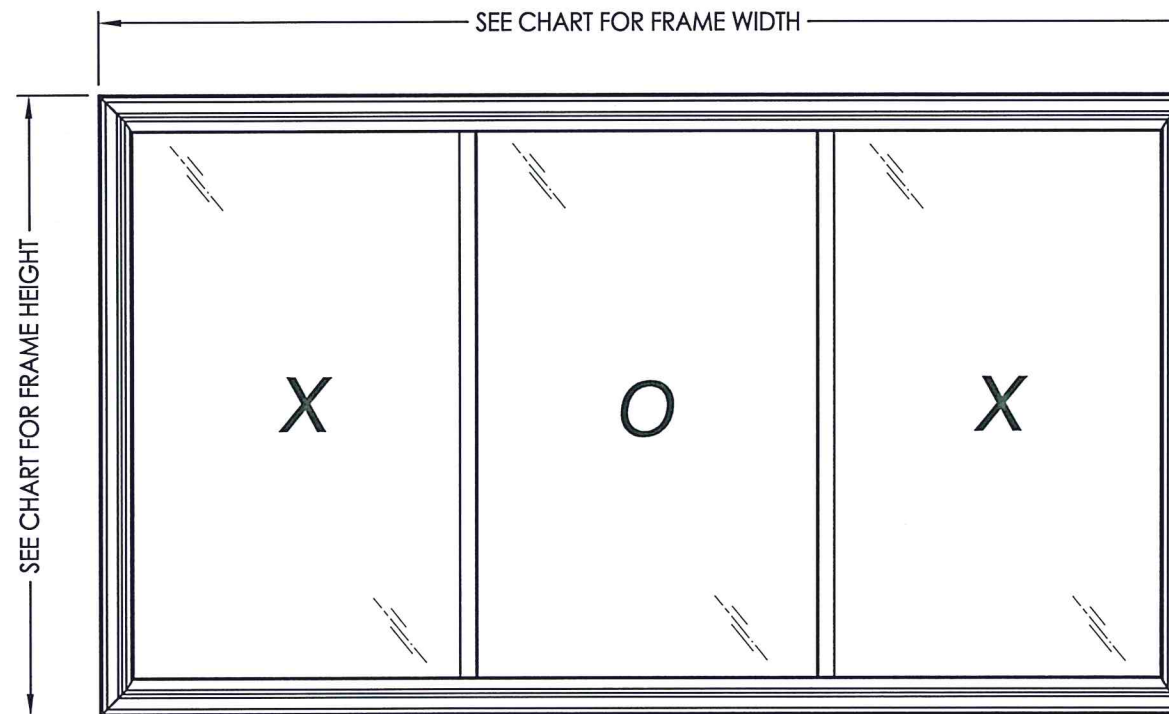

OVERALL FRAME DIMENSION	FIXED DAY LIGHT DIMENSION	SASH DAY LIGHT DIMENSION	GLASS TYPE	DESIGN PRESSURE (PSF)	
				POS.	NEG.
108.0" x 56.0"	32.25" x 47.62"	32.25" x 47.62"	G1	+30.0	-30.0
108.0" x 48.0"	32.25" x 39.62"	32.25" x 39.62"		+35.0	-40.0



Documents Prepared By: Lyndon F. Schmidt, P.E.
TEXAS P.E. #104123

RW BUILDING CONSULTANTS, INC.
P.O. Box 230 Valrico FL 33595
Phone No.: 813.659.9197

TEXAS BOARD OF PROFESSIONAL ENGINEERS
CERTIFICATE OF REGISTRATION # F-11852

PRODUCT: HORIZONTAL SLIDER

PART OR ASSEMBLY: TYPICAL ELEVATION, DESIGN PRESSURES & GENERAL NOTES

NO.	DATE	BY	REVISIONS

DATE: 8/24/20
SCALE: N.T.S.
DWG. BY: RW
CHK. BY: LFS
DRAWING NO.: TX-5107
SHEET 1 OF 3

Z:\Clients\Associated PERMANENT B - Texas Dept of Ins\Horizontal Slider\WIN 94 Series 0500 Horizontal Slider\C - Drawings\TX-5105.06.07.dwg

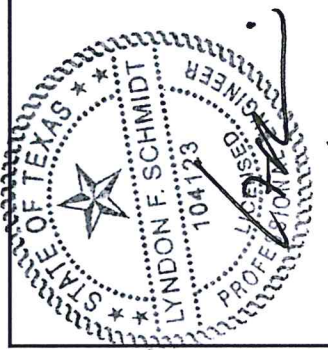
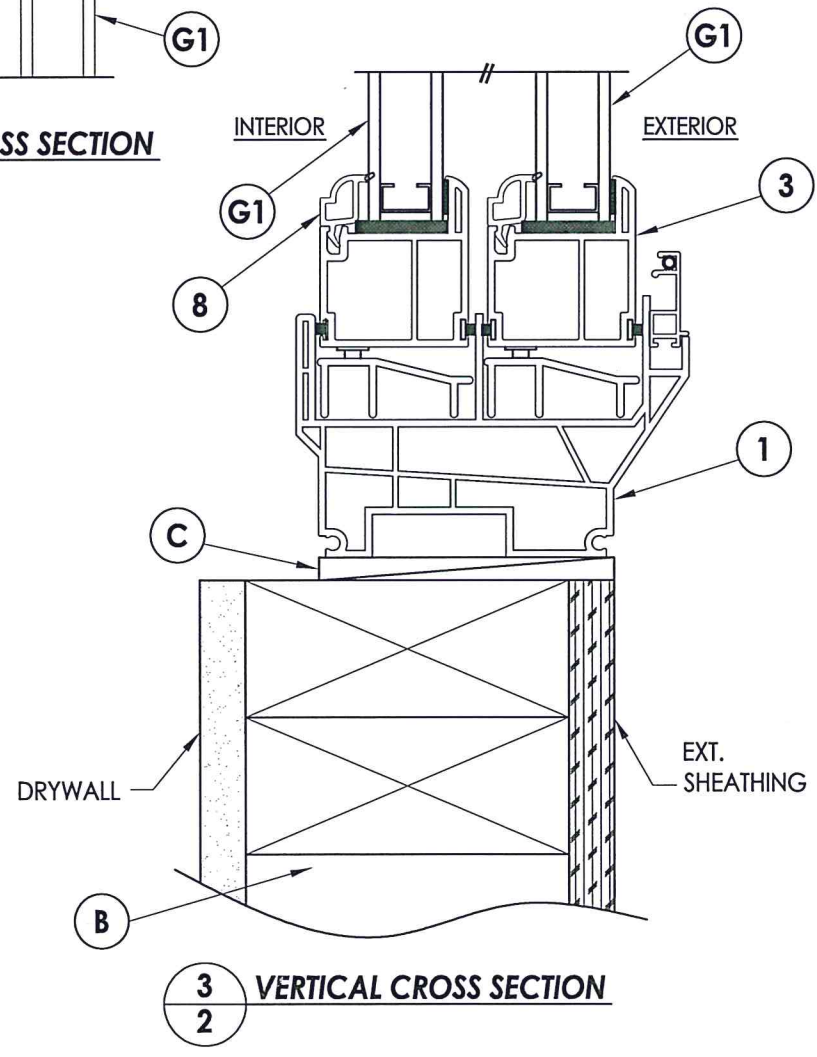
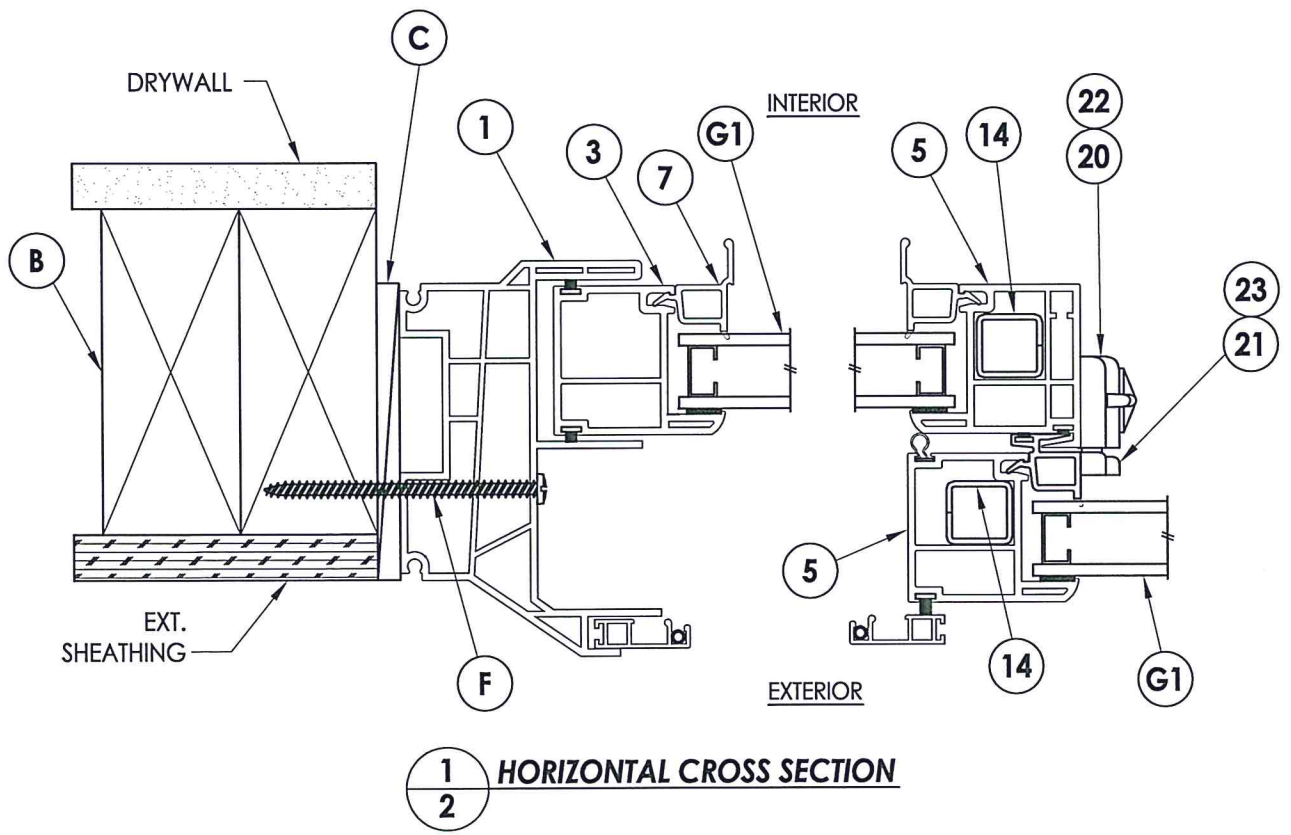
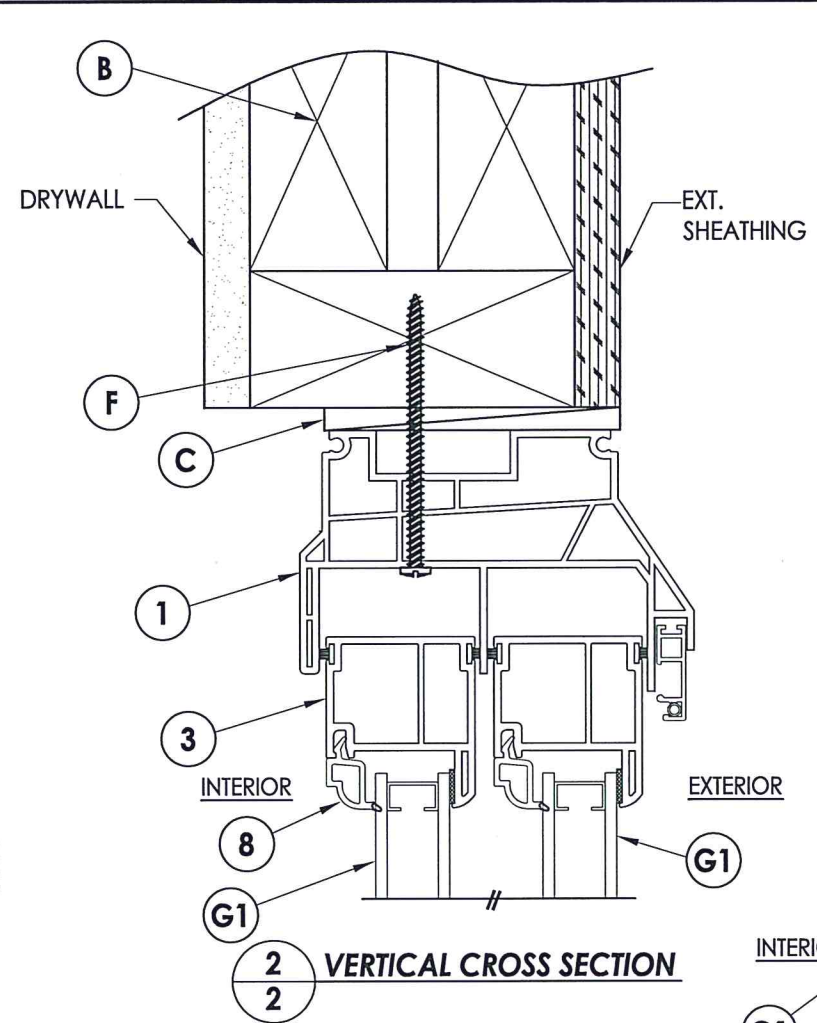
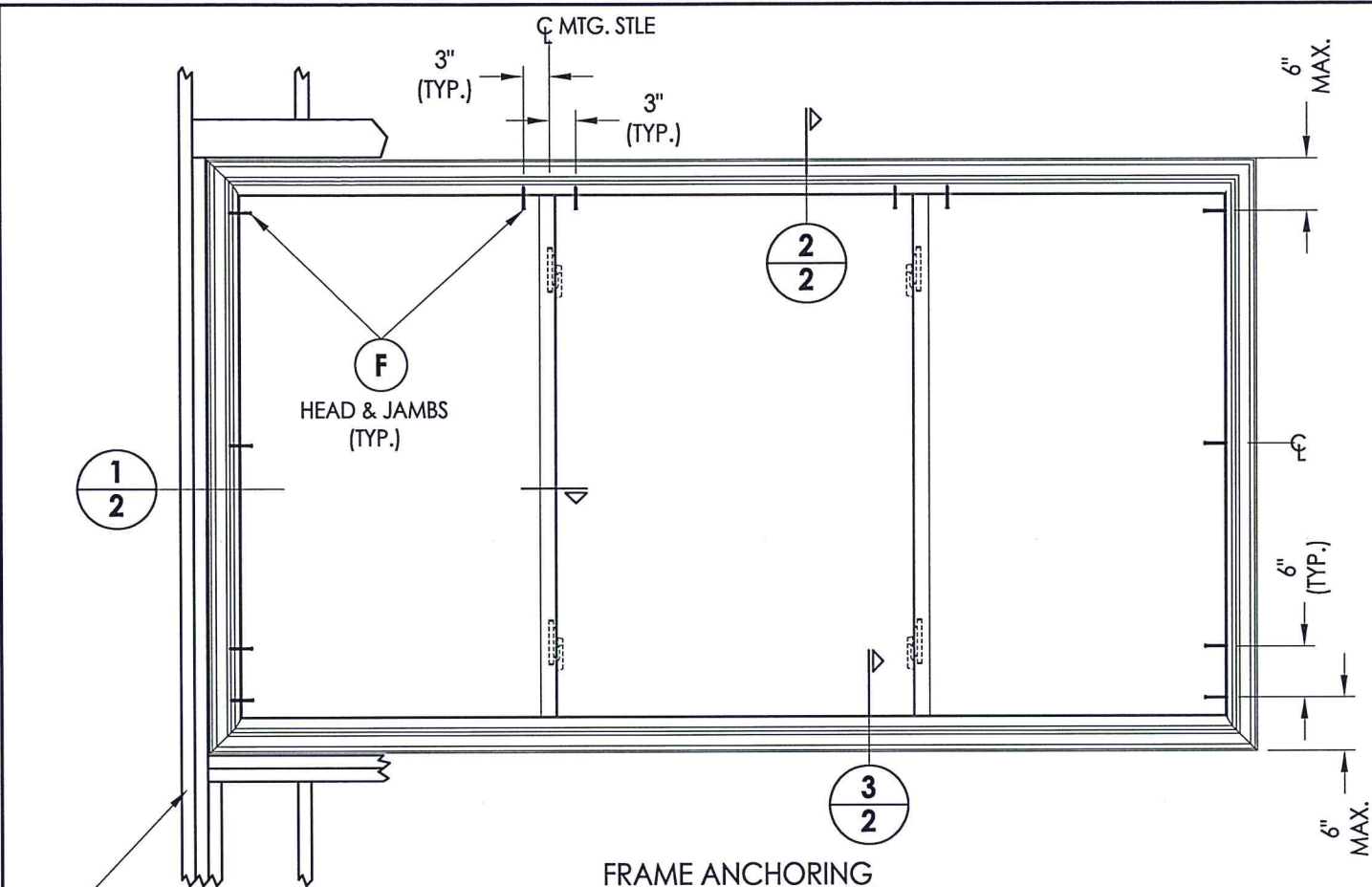

Documents Prepared By: Lyndon F. Schmidt, P.E.
TEXAS P.E. #104123

RW BUILDING CONSULTANTS, INC.
P.O. Box 230 Valrico FL, 33595
Phone No.: 813.659.9197

TEXAS BOARD OF PROFESSIONAL ENGINEERS
CERTIFICATE OF REGISTRATION # F-11852

PRODUCT:	HORIZONTAL SLIDER	
PART OR ASSEMBLY:	VERTICAL & HORIZONTAL CROSS SECTIONS & FRAME ANCHORING	
NO.	DATE	BY
		REVISIONS
DATE:	8/24/20	
SCALE:	N.T.S.	
DWG. BY:	RW	
CHK. BY:	LFS	
DRAWING NO.:	TX-5107	
SHEET	2	OF 3

Z:\Clients\Associated PERMANENT\B - Texas Dept of Ins\Horizontal Slider\WIN 94 Series 0500 Horizontal Slider\C - Drawings\TX-5105.06.07.dwg

BILL OF MATERIALS		
ITEM	DESCRIPTION	MATERIAL
B	2X FRAMING (SG >= 0.42)	WOOD
C	MAX. 3/16" SHIM SPACE	-
F	#10 X 3" PPH SMS (1-1/4" MIN. EMBEDMENT)	STEEL
1	EXTRUDED VINYL FRAME *	RIGID PVC
3	EXTRUDED VINYL SASH *	RIGID PVC
5	EXTRUDED VINYL MEETING STILE *	RIGID PVC
7	EXTRUDED VINYL GLAZING BEAD "A" *	RIGID PVC
8	EXTRUDED VINYL GLAZING BEAD "C" *	RIGID PVC
14	LOCK REINFORCEMENT (UY0088)	STEEL
17	"U" SHAPED METAL SPACER	STEEL
18	SETTING BLOCK	-
19	DOUBLE SIDED ADHESIVE GLAZING TAPE	-
20	SWEEP LOCK	STEEL
21	KEEPER	STEEL
22	#8 X 1" PFH SCREW	STEEL
23	#6 X 1" PFH SCREW	STEEL
32	EXTRUDED VINYL GLAZING BEAD "B" *	RIGID PVC

*THE APPROVED WHITE RIGID PVC EXTERIOR EXTRUSIONS FOR WINDOWS ARE TO BE PRODUCED BY EXTRUDERS LICENSEES IN "AAMA CERTIFICATION PROGRAMS FOR RIGID PVC EXTRUSIONS."

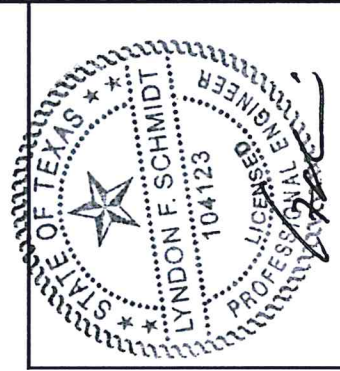
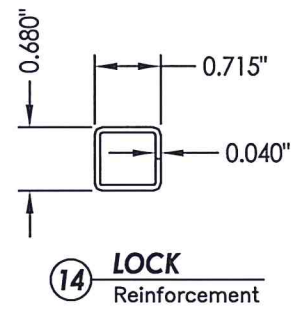
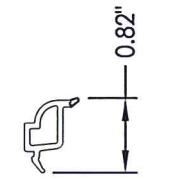
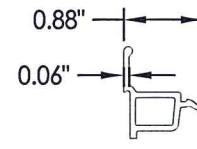
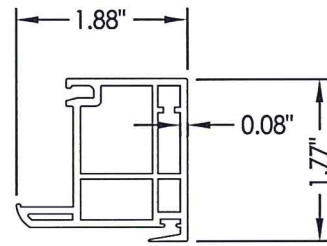
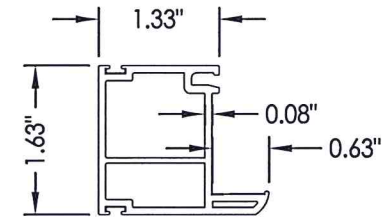
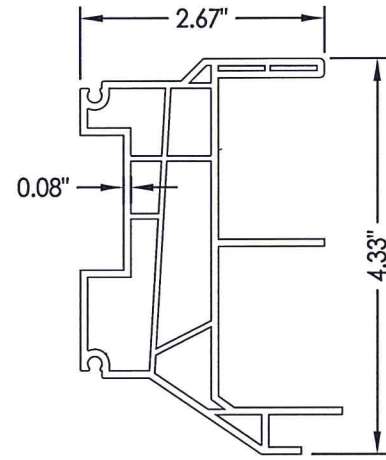
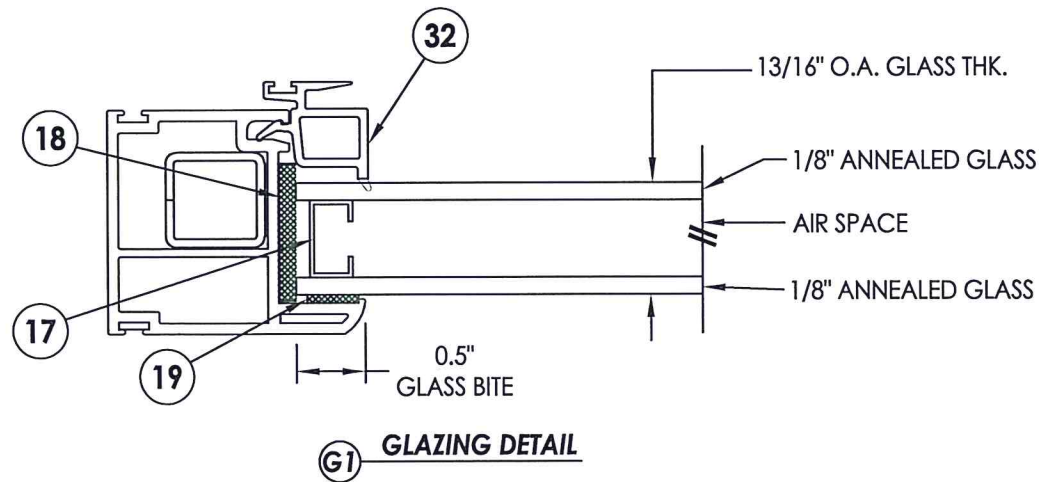

Documents Prepared By: Lyndon F. Schmidt, P.E.
TEXAS P.E. #104123

RW BUILDING CONSULTANTS, INC.
P.O. Box 230 Valrico FL 33595
Phone No.: 813.659.9197

TEXAS BOARD OF PROFESSIONAL ENGINEERS
CERTIFICATE OF REGISTRATION # F-11852

PRODUCT:	HORIZONTAL SLIDER	
PART OR ASSEMBLY:	BILL OF MATERIALS, GLAZING DETAILS & COMPONENTS	
NO.	DATE	BY
REVISIONS		
DATE:	8/24/20	
SCALE:	N.T.S.	
DWG. BY:	RW	
CHK. BY:	LFS	
DRAWING NO.:	TX-5107	
SHEET	3	OF 3