

Documents Prepared By: Lyndon F. Schmidt, P.E.  
TEXAS P.E. #104123  
**RW** BUILDING CONSULTANTS, INC.  
P.O. Box 230 Vairico FL 33595  
Phone No.: 813.659.9197  
TEXAS BOARD OF PROFESSIONAL ENGINEERS  
CERTIFICATE OF REGISTRATION # F-11852

# MODEL 9009/9E09 HORIZONTAL SLIDER "NON-IMPACT"

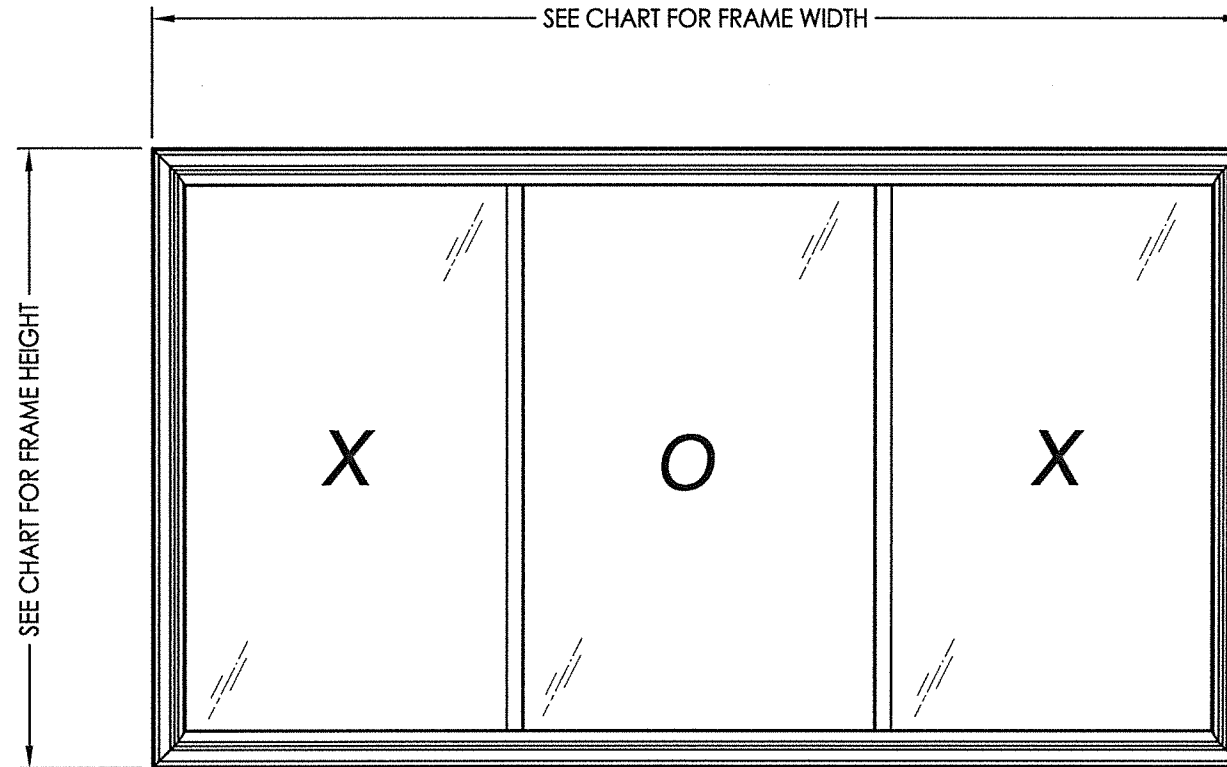

**EVALUATED FOR USE IN THE STATE OF TEXAS**

The Horizontal Slider Window described herein complies with the 2018 International Residential Code (IRC), Sections R301 & R609 and the 2018 International Building Code (IBC), Sections 1404.13, 1609, 1709.5, 2403 and 2404 subject to the following conditions:

1. Anchors shall be as listed and spaced as shown in the details. Anchor embedment to base material shall be beyond wall dressing or stucco.
2. When used in areas requiring wind-borne debris protection this product is required to be protected with an impact resistant covering that complies with Section R301.2.1.2 of the IRC and Section 1609.2 of the IBC.
3. Allowable design pressure requirements must be equal to or less than the design pressure rating shown in the design pressure chart, sheet 1 of this drawing.
4. Conditions not covered by this drawing are subject to further engineering analysis.

TABLE OF CONTENTS	
SHEET#	DESCRIPTION
1	Typical elevations, design pressures & general notes
2	Vertical & horizontal cross sections & frame anchoring
3	Bill of materials, glazing detail and components

OVERALL FRAME DIMENSION	FIXED DAY LIGHT DIMENSION	OPERABLE DAY LIGHT DIMENSION	DESIGN PRESSURE (PSF)	
			POSITIVE	NEGATIVE
108.0" x 48.0"	32.25" x 39.62"	32.25" x 39.62"	+40.0	-40.0

PRODUCT: HORIZONTAL SLIDER	
PART OR ASSEMBLY: TYPICAL ELEVATION, DESIGN PRESSURES & GENERAL NOTES	
NO.	DATE
BY	REVISIONS
DATE: 4/27/21	
SCALE: N.T.S.	
DWG. BY: RW	
CHK. BY: LFS	
DRAWING NO.: TX-5181	
SHEET 1 OF 3	

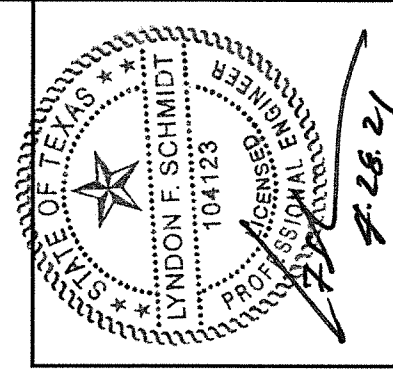
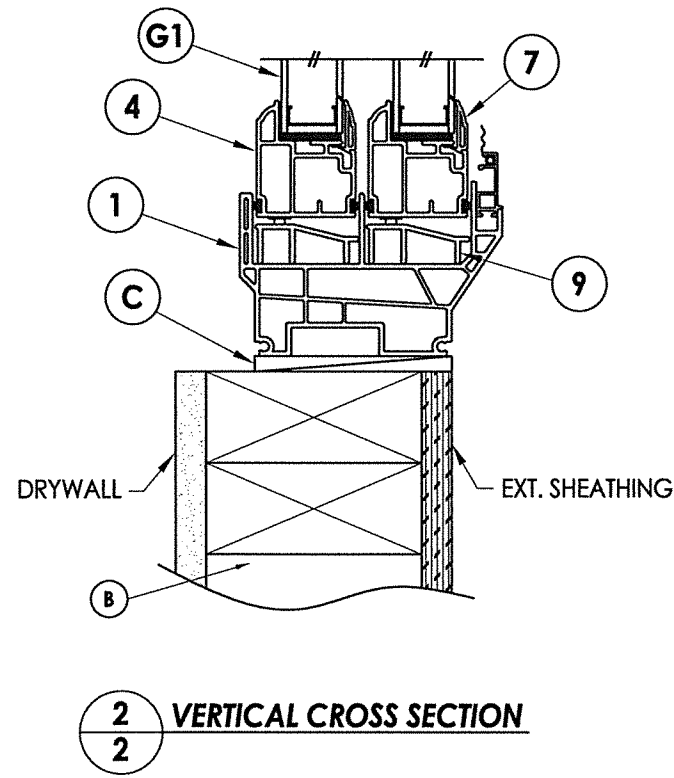
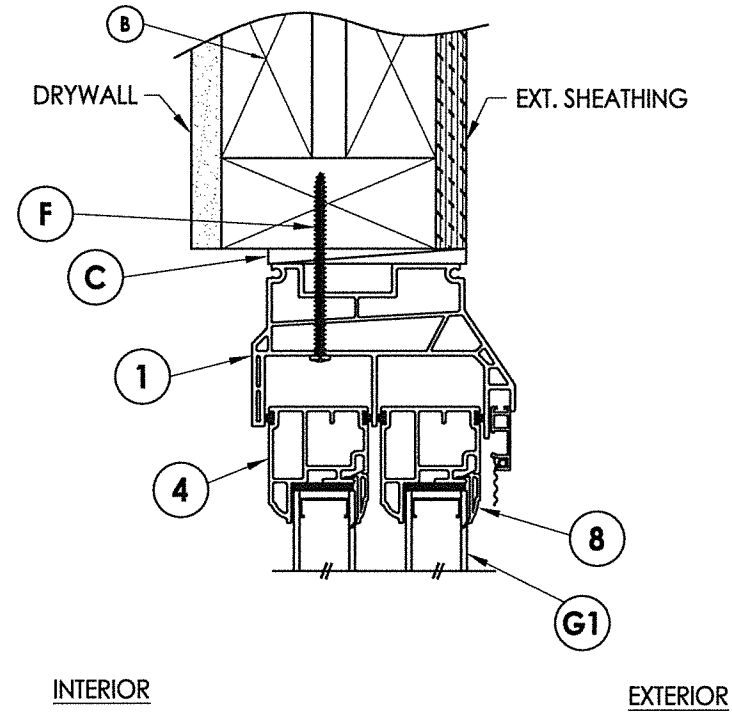
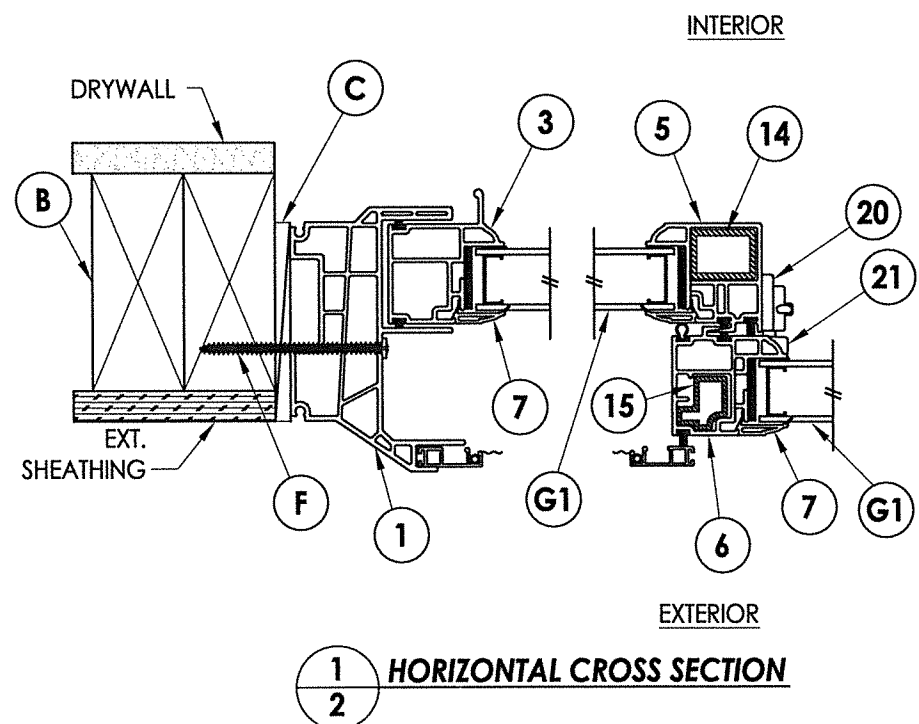
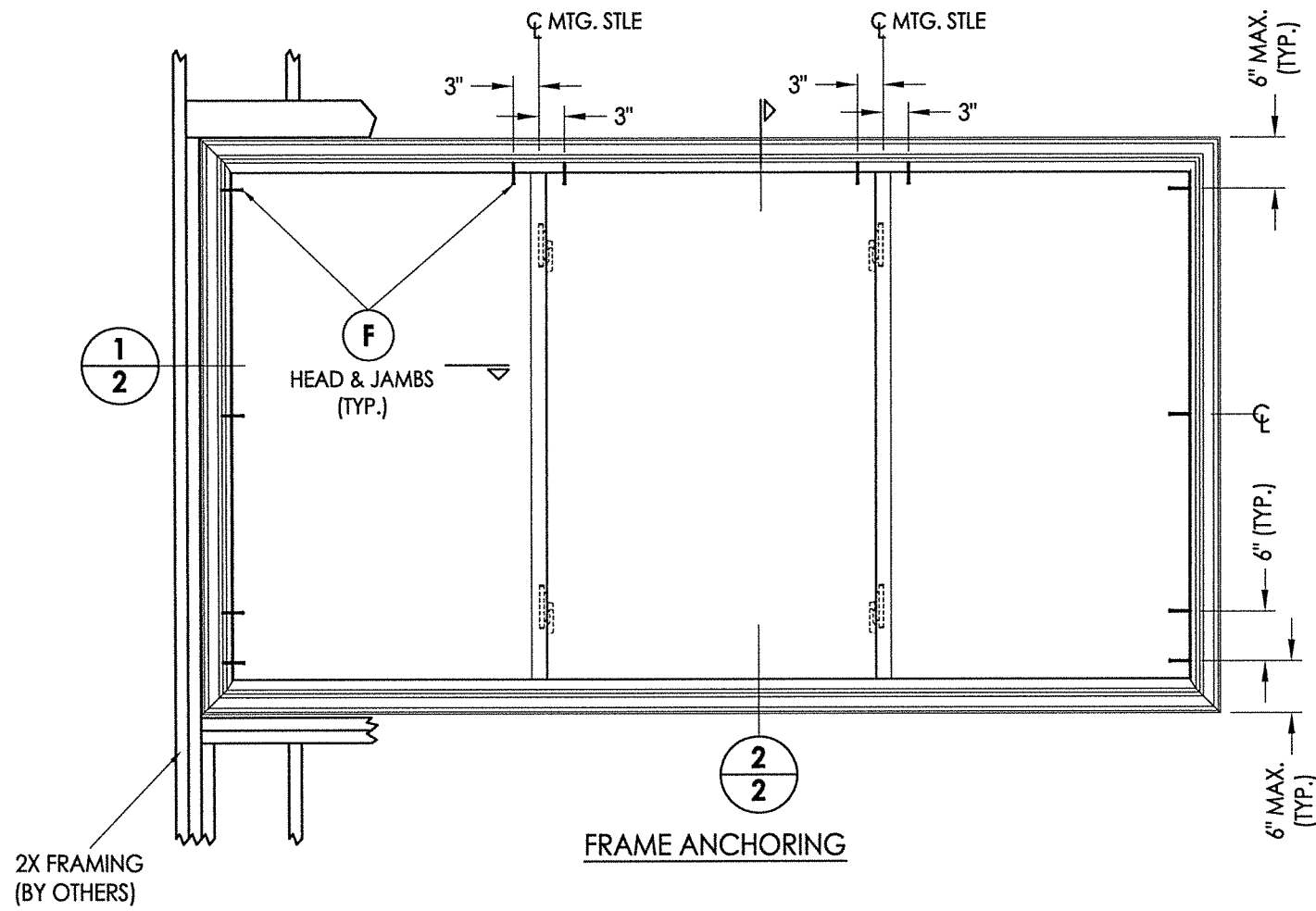

Documents Prepared By: Lyndon F. Schmidt, P.E.  
TEXAS P.E. #104123

**RW** BUILDING CONSULTANTS, INC.  
P.O. Box 230 Valrico FL, 33595  
Phone No.: 813.689.9197

TEXAS BOARD OF PROFESSIONAL ENGINEERS  
CERTIFICATE OF REGISTRATION # F-11852

PRODUCT: HORIZONTAL SLIDER

PART OR ASSEMBLY: VERTICAL & HORIZONTAL CROSS SECTIONS & FRAME ANCHORING

NO.	DATE	BY

DATE: 4/27/21

SCALE: N.T.S.

DWG. BY: RW

CHK. BY: LFS

DRAWING NO.: TX-5181

SHEET 2 OF 3

### BILL OF MATERIALS

ITEM #	DESCRIPTION	MATERIAL
B	2X FRAMING (SG >= 0.42)	WOOD
C	1/4" MAX. SHIM SPACE	-
F	#10 X 3" PPH SMS (1-1/4" MIN. EMBEDMENT)	STEEL
1	EXTRUDED VINYL FRAME *	RIGID PVC
3	EXTRUDED VINYL SASH HANDLE STILE *	RIGID PVC
4	EXTRUDED VINYL SASH RAIL *	RIGID PVC
5	EXTRUDED VINYL MEETING STILE *	RIGID PVC
6	EXTRUDED VINYL LOCK STILE *	RIGID PVC
7	EXTRUDED VINYL GLAZING BEAD *	RIGID PVC
9	EXTRUDED VINYL SLIDER TRACK *	RIGID PVC
14	LOCK STILE REINFORCEMENT (UY0129XX)	FIBERGLASS
15	KEEPER STILE REINFORCEMENT (UY0132XX)	FIBERGLASS
17	"U" SHAPED STEEL SPACER	STEEL
18	SETTING BLOCK	-
19	DOUBLE SIDED ADHESIVE GLAZING TAPE	-
20	CAM LOCK (ASHLAND)	STEEL
21	KEEPER	STEEL

\*THE APPROVED WHITE RIGID PVC EXTERIOR EXTRUSIONS FOR WINDOWS ARE TO BE PRODUCED BY EXTRUDERS LICENSEES IN "AAMA CERTIFICATION PROGRAMS FOR RIGID PVC EXTRUSIONS."

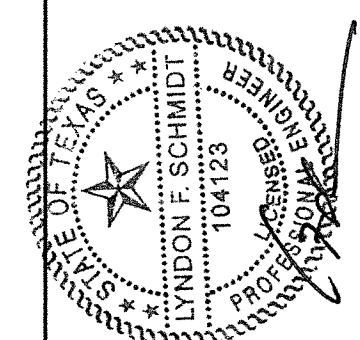
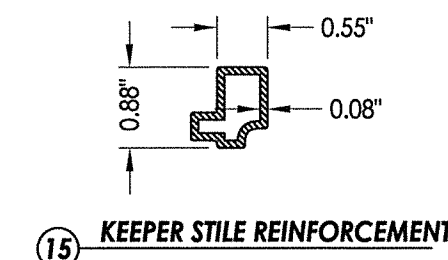
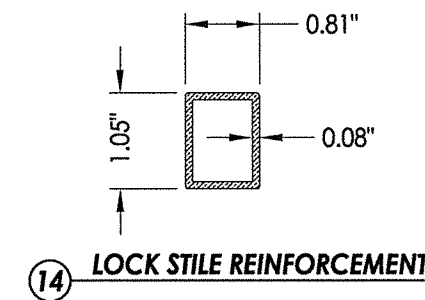
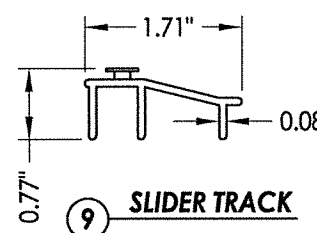
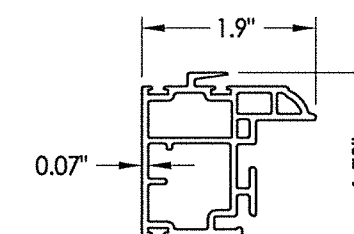
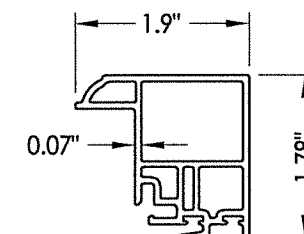
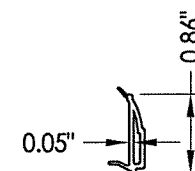
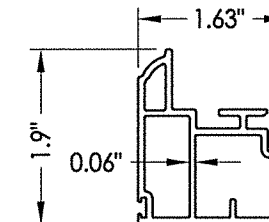
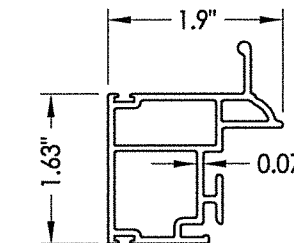
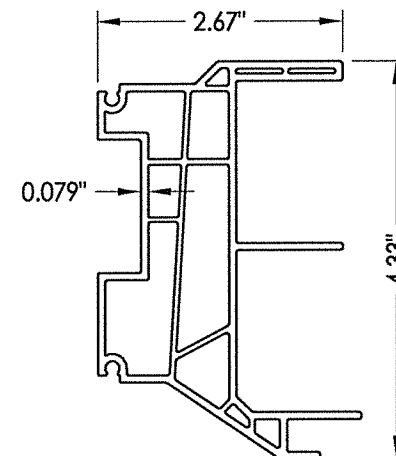
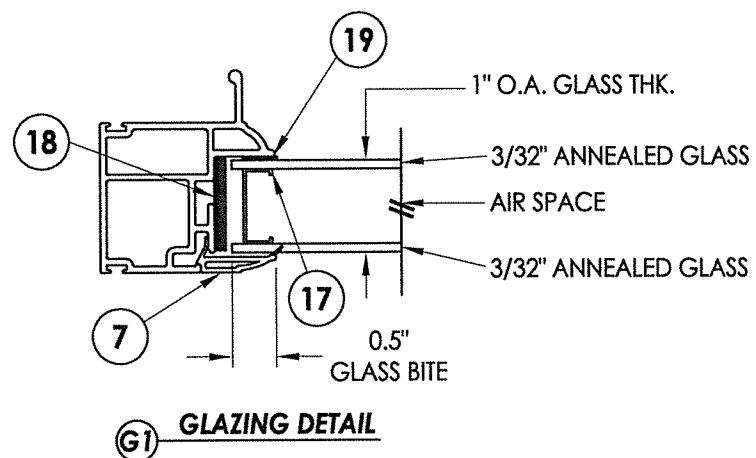

Documents Prepared By: Lyndon F. Schmidt, P.E.  
TEXAS P.E. #104123

**RW** BUILDING CONSULTANTS, INC.  
P.O. Box 230 Valrico FL 33595  
Phone No.: 813.659.9197

TEXAS BOARD OF PROFESSIONAL ENGINEERS  
CERTIFICATE OF REGISTRATION # F-11852

PRODUCT: HORIZONTAL SLIDER

PART OR ASSEMBLY: BILL OF MATERIALS, GLAZING DETAILS & COMPONENTS

NO.	DATE	BY	REVISIONS

DATE: 4/27/21  
SCALE: N.T.S.  
DWG. BY: RW  
CHK. BY: LFS  
DRAWING NO.: TX-5181  
SHEET 3 OF 3