

MODEL 8100 SYSTEM 4 SINGLE HUNG - NON-IMPACT

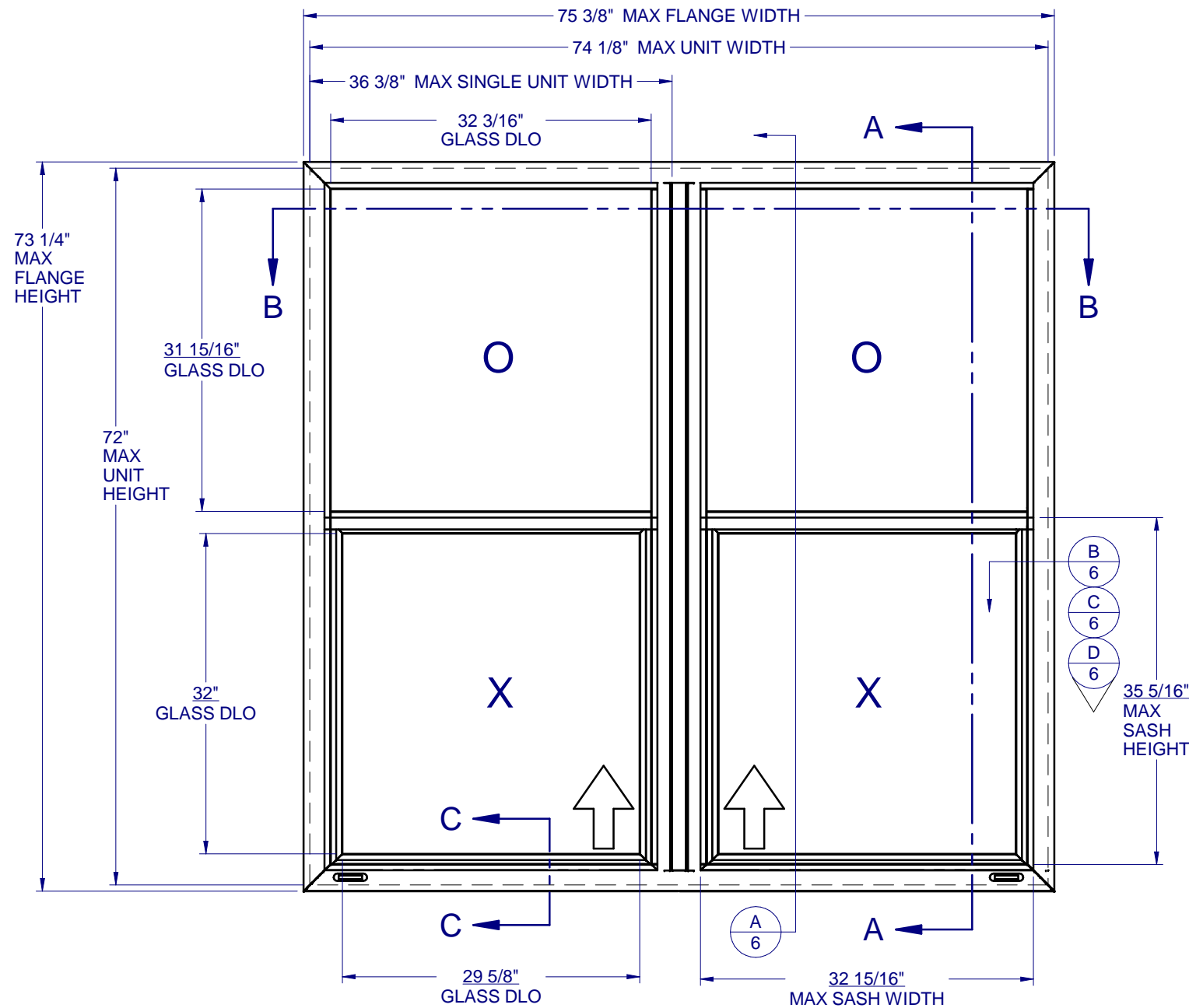

SYSTEM 4 (CAR 138-492)
MAXIMUM ALLOWABLE DESIGN PRESSURE: +65/-65 PSF

TABLE OF CONTENTS

GENERAL NOTES & ELEVATIONS.....	1
DP CHART & GLAZING DETAIL.....	2
SECTION VIEWS & ALT. FRAME.....	3
EXTRUSIONS & B.O.M.....	4
ANCHOR SCHEDULE & NOTES.....	5
INSTALLATION DETAILS.....	6

GENERAL NOTES:

1. THE PRODUCT SHOWN HEREIN IS DESIGNED AND MANUFACTURED TO COMPLY WITH THE REQUIREMENTS OF THE 2018 INTERNATIONAL BUILDING CODE AND 2018 INTERNATIONAL RESIDENTIAL CODE.
2. GLAZING OPTIONS: (SEE SHEET 2)
3. CONFIGURATIONS: "O/X" - "O/X".
4. ANCHORAGE: THE 33 1/3% STRESS INCREASE HAS NOT BEEN USED IN THE DESIGN OF THIS PRODUCT. SEE SHEET 6 FOR ANCHOR DETAILS. WINDLOAD DURATION FACTOR Cd=1.6 WAS USED FOR WOOD ANCHOR CALCULATIONS.
5. NOT APPROVED FOR IMPACT RESISTANCE. IMPACT PROTECTIVE SYSTEM IS REQUIRED IN WIND BORNE DEBRIS REGION.
6. ALL FRAMES AND VENTS FULLY WELDED. SMALL JOINT SEAM SEALANT USED AT FIXED MEETING RAIL, INTERNAL MULL ENDS AND JAMBS.
7. SERIES / MODEL DESIGNATION SH-8100 CONTINUOUS FRAME.
8. THE DESIGNATION X AND O STAND FOR THE FOLLOWING:
X = OPERABLE SASH, O = FIXED SASH
9. SECTION CALLOUTS APPLY TO ALL ELEVATIONS IN A SIMILAR LOCATION.
10. EXTERNAL WEEP SLOT = 1/4" x 1" LOCATED 4" FROM BOTH ENDS.

Custom
WINDOW SYSTEMS
 1900 SW 44TH AVE.
 OCALA, FLORIDA 34474
 WWW.CWS.CC

8100 PVC SINGLE HUNG NON-IMPACT

NO.	DESCRIPTION:	BY:	DATE:
C	REVISED TO TDI REQUEST	MS	12/14/21
B	REVISED TO TDI REQUEST	JML	3/20/17
A	REVISED TO TDI REQUEST	JML	8/2/16

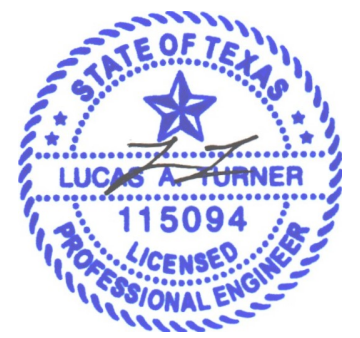

1/14/2021

LUCAS A. TURNER, P.E.
 TX PE # 115094
 2428 OLD NATCHEZ TRC TRL
 CAMDEN, TN 38320
 PH. 941-380-1574

SHEET DESCRIPTION:

**GENERAL NOTES AND
ELEVATIONS**

DRAWN BY:	DATE:
EMK	11/10/15
DWG #:	REV.:
TDI-492	C
SCALE:	SHEET
1:25	1 OF 6

**8100 PVC
SINGLE HUNG
NON-IMPACT**

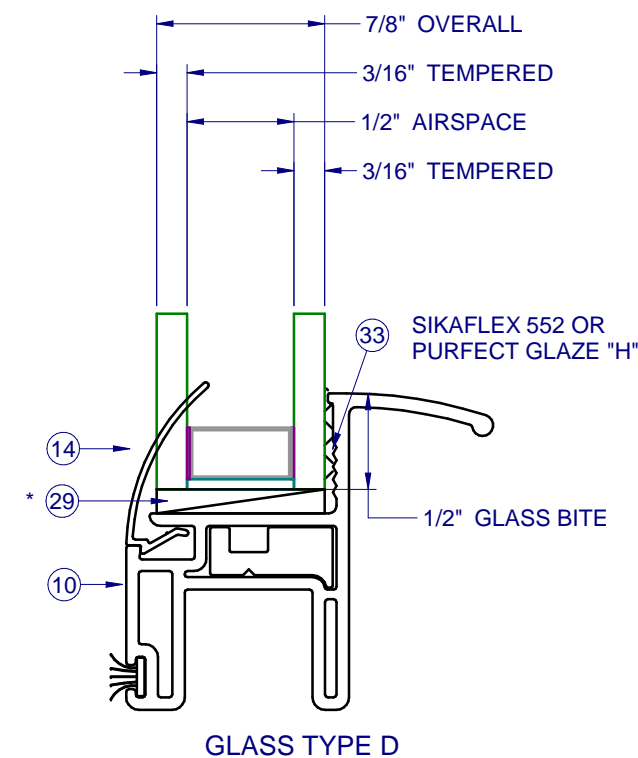
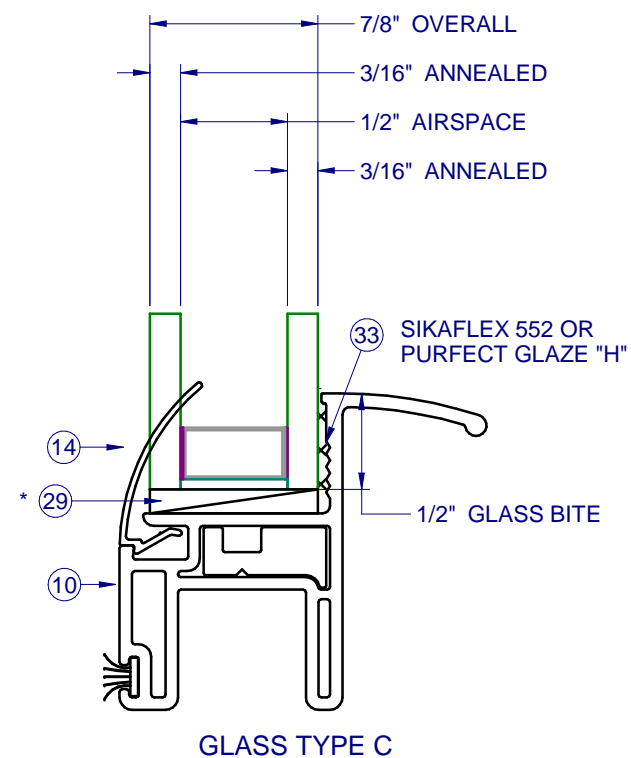
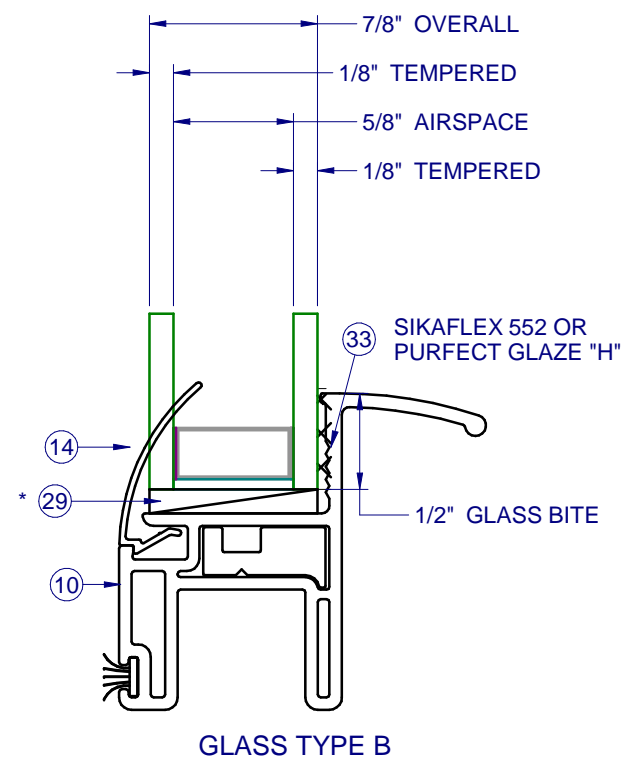
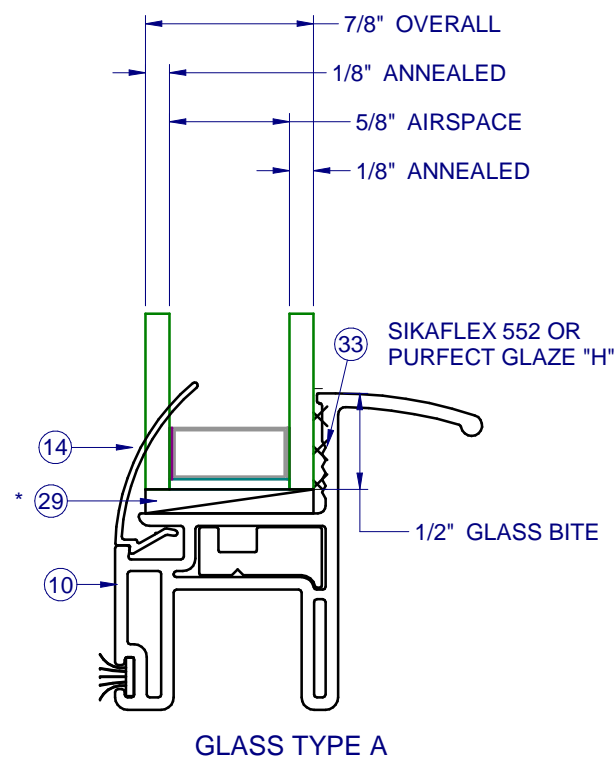

NO.	DESCRIPTION:	BY:	DATE:
C	REVISED TO TDI REQUEST	MS	12/14/21
B	REVISED TO TDI REQUEST	JML	3/20/17
A	REVISED TO TDI REQUEST	JML	8/2/16



1/14/2021

LUCAS A. TURNER, P.E.
TX PE # 115094
2428 OLD NATCHEZ TRC TRL
CAMDEN, TN 38320
PH. 941-380-1574

SHEET DESCRIPTION:
GLAZING DETAIL

DRAWN BY: EMK	DATE: 11/10/15
DWG #: TDI-492	REV.: C
SCALE: 1:1	SHEET 2 OF 6

**8100 PVC
SINGLE HUNG
NON-IMPACT**

NO.	DESCRIPTION:	BY:	DATE:
C	REVISED TO TDI REQUEST MS	JML	12/14/21
B	REVISED TO TDI REQUEST JML	JML	3/20/17
A	REVISED TO TDI REQUEST JML	JML	8/2/16

REVISIONS



1/14/2021

LUCAS A. TURNER, P.E.
TX PE # 115094
2428 OLD NATCHEZ TRC TRL
CAMDEN, TN 38320
PH. 941-380-1574

SHEET DESCRIPTION:

SECTION VIEWS

DRAWN BY:	DATE:
EMK	11/10/15
DWG #:	REV.:
TDI-492	C
SCALE:	SHEET
1:2	3 OF 6

INTERIOR

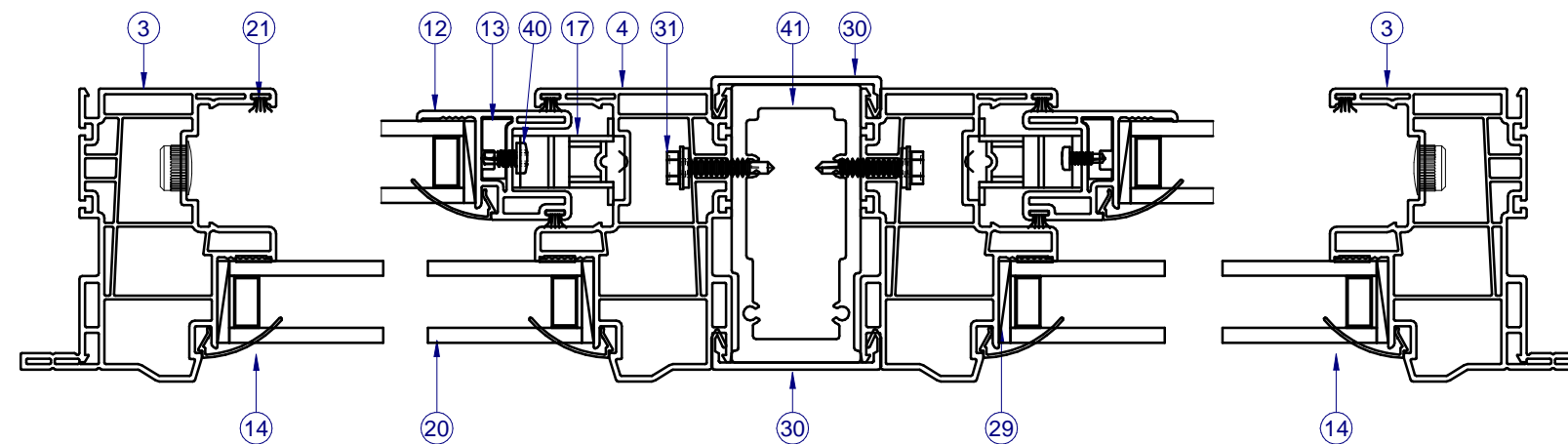

SECTION B-B

INTERIOR

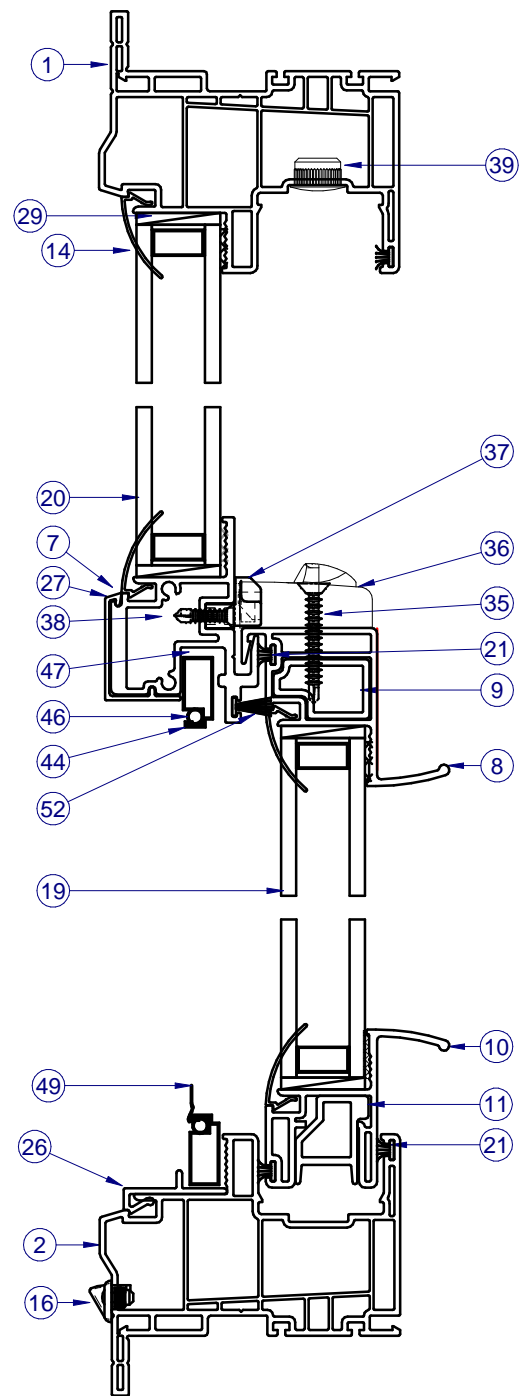

SECTION A-A

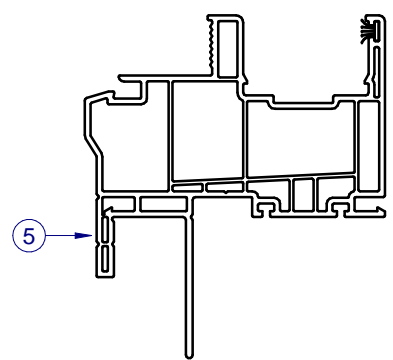

SECTION C-C
ALTERNATE FIN FRAME

NOTE: ITEMS NOT SHOWN FOR CLARITY:
6, 15, 18, 32, 34, 42, 45, 48

PARTS LIST			
ITEM	PART #	DESCRIPTION	MATERIAL
1	H-6222	Frame Head, Flg,	Vinyl
2	H-6222	Frame Sill, Flg,	Vinyl
3	H-6222	Frame Jamb, Flg,	Vinyl
4	H-6222	Internal Fr.,Jb.	Vinyl
5	H-6231	Frame, Fin	Vinyl
6	S-6025	Sash Stop / Filler	Vinyl
7	H-2121	Alum. Fixed Meet. Rail	Alum
8	H-6224	Sash Top Rail	Vinyl
9	H-2124	Reinforcement for STR	Alum
10	H-6223	Sash Bottom Rail	Vinyl
11	H-2123	Reinforcement for SBR	Alum
12	H-6225	Sash Side Rail	Vinyl
13	S-2129	Reinforcement for SSR	Alum
14	S-6237	Glazing Bead	Vinyl
15	P-3059	Sash Cam	Plastic
16	P-4479	Weep Housing & Flap Assm.	Plastic
17		Block & Tackle Balance	
18	P-3295	Take Out Clip	SS
19		Glass, Sash (See Sheet 2)	
20		Glass, Fixed (See Sheet 2)	
21	P-3429	Wstp., 0.270 x 0.187 back FinSeal	
22	P-4638	#8 x 2-1/2 Ph Mod. Truss, Type A, Tek 2	Steel
23		#10 x 1 1/2" Panhead SMS	Steel
25	S-6227	Screen Support	Vinyl
26	S-6226	Screen Catch	Vinyl
27	S-6228	Fixed Rail Cover	Vinyl
29	P-5615	Set. Blk. 1/8" x 1" x 2"	Rubber
30	S-6018	Mullbar Cover	Vinyl
31	P-3767	#10 x 1 Hex Head Tek	Steel
32	P-3342	Seam Sealer, SM-5504	
33		SikaFlex 552 or Purfect Glaze "H"	
35	P-4051	#8 x 1 1/4" PH Flat Tek	Steel
36	P-3783	Lock	
37	P-4069	Keeper	Zamac
38	P-4264	#8 x 3/4" PH Flat w/ #6 Head	Steel
39	P-5588	Hole Plug	Nylon
40	P-3559	#8 x 3/8" PH Pan Tek	Steel
41	H-2127	Internal Mullbar	Alum
43	P-4638	#8 x 2 1/4 Square Modified Truss	Steel
44	P-3218	Screen frame	Alum
45	P-3321	Screen Corner Key	Plastic
46	P-3228	Screen Spline	Vinyl
47	P-3033	Screen Spring	SS
48	P-3029	Screen Pull tab	Alum
49	P-3581	Screen Material	Fiberglass
52	P-4959	Wstp., 0.420 x 0.187 back	

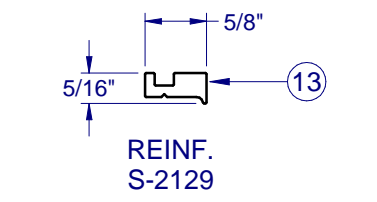
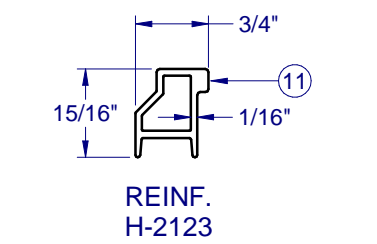
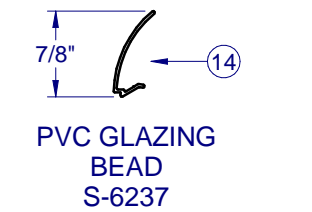
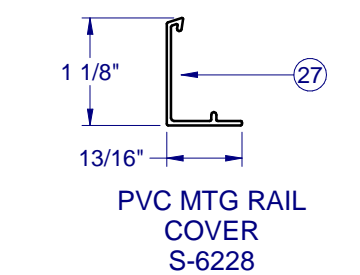
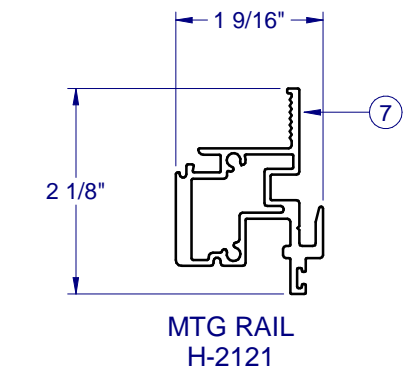
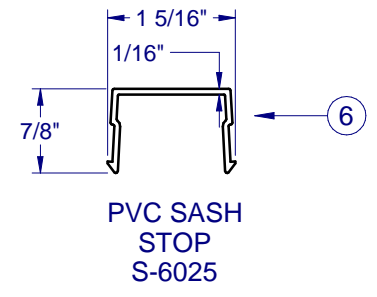
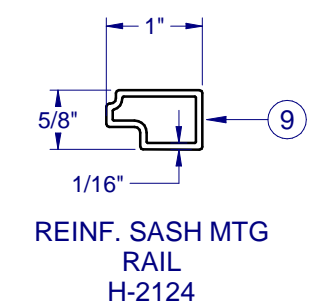
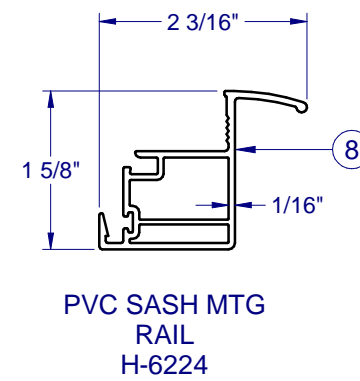
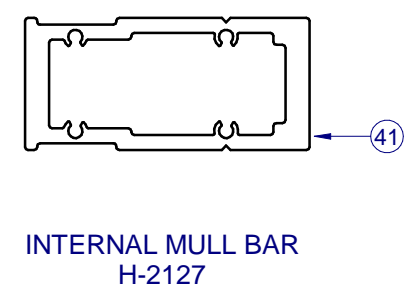
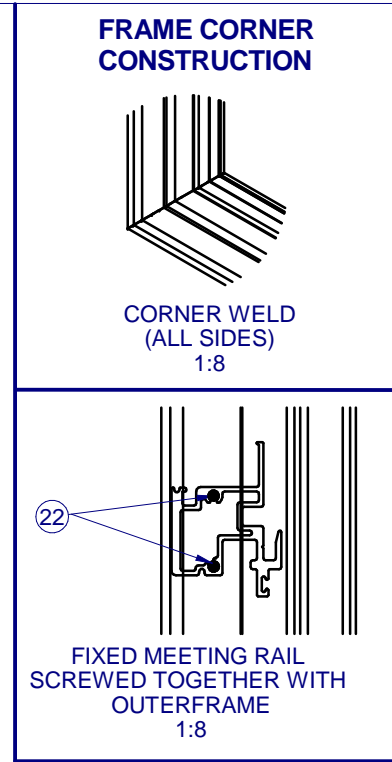
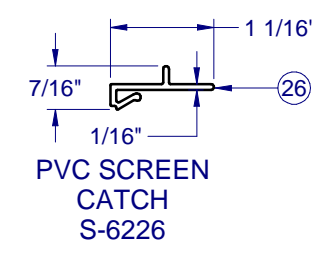
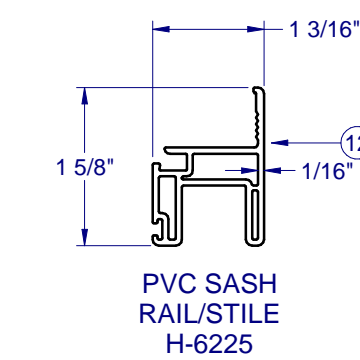
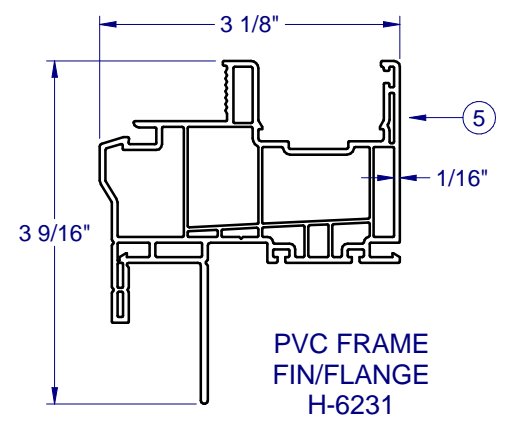
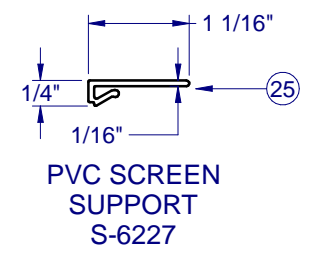
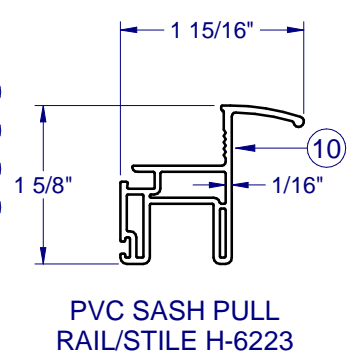
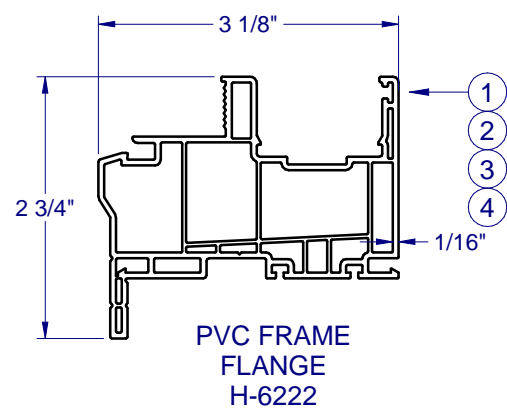

Custom WINDOW SYSTEMS
 1900 SW 44TH AVE.
 OCALA, FLORIDA 34474
 WWW.CWS.CC

8100 PVC SINGLE HUNG NON-IMPACT

NO.	DESCRIPTION:	BY:	DATE:
C	REVISED TO TDI REQUEST MS	JML	12/14/21
B	REVISED TO TDI REQUEST JML	JML	3/20/17
A	REVISED TO TDI REQUEST JML	JML	8/2/16

REVISIONS

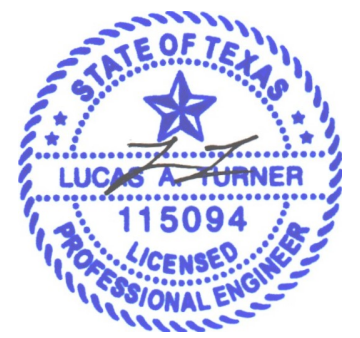

1/14/2021

LUCAS A. TURNER, P.E.
 TX PE # 115094
 2428 OLD NATCHEZ TRC TRL
 CAMDEN, TN 38320
 PH. 941-380-1574

SHEET DESCRIPTION:
BOM AND EXTRUSIONS

DRAWN BY:	DATE:
EMK	11/10/15
DWG #:	REV.:
TDI-492	C
SCALE:	SHEET
1:2	4 OF 6

LINE ITEMS NOT USED:
 34, 42, 50-51

NOTE: ALL EXTRUSIONS ARE ALUMINUM 6063-T6 UNLESS OTHERWISE NOTED.

**8100 PVC
SINGLE HUNG
NON-IMPACT**

NO.	DESCRIPTION:	BY:	DATE:
C	REVISED TO TDI REQUEST MS	JML	12/14/21
B	REVISED TO TDI REQUEST JML	JML	3/20/17
A	REVISED TO TDI REQUEST JML	JML	8/2/16

REVISIONS



1/14/2021

LUCAS A. TURNER, P.E.
TX PE # 115094
2428 OLD NATCHEZ TRC TRL
CAMDEN, TN 38320
PH. 941-380-1574

SHEET DESCRIPTION:
ANCHOR SCHEDULE AND NOTES

DRAWN BY: EMK	DATE: 11/10/15
DWG #: TDI-492	REV.: C
SCALE: 1:20	SHEET 5 OF 6

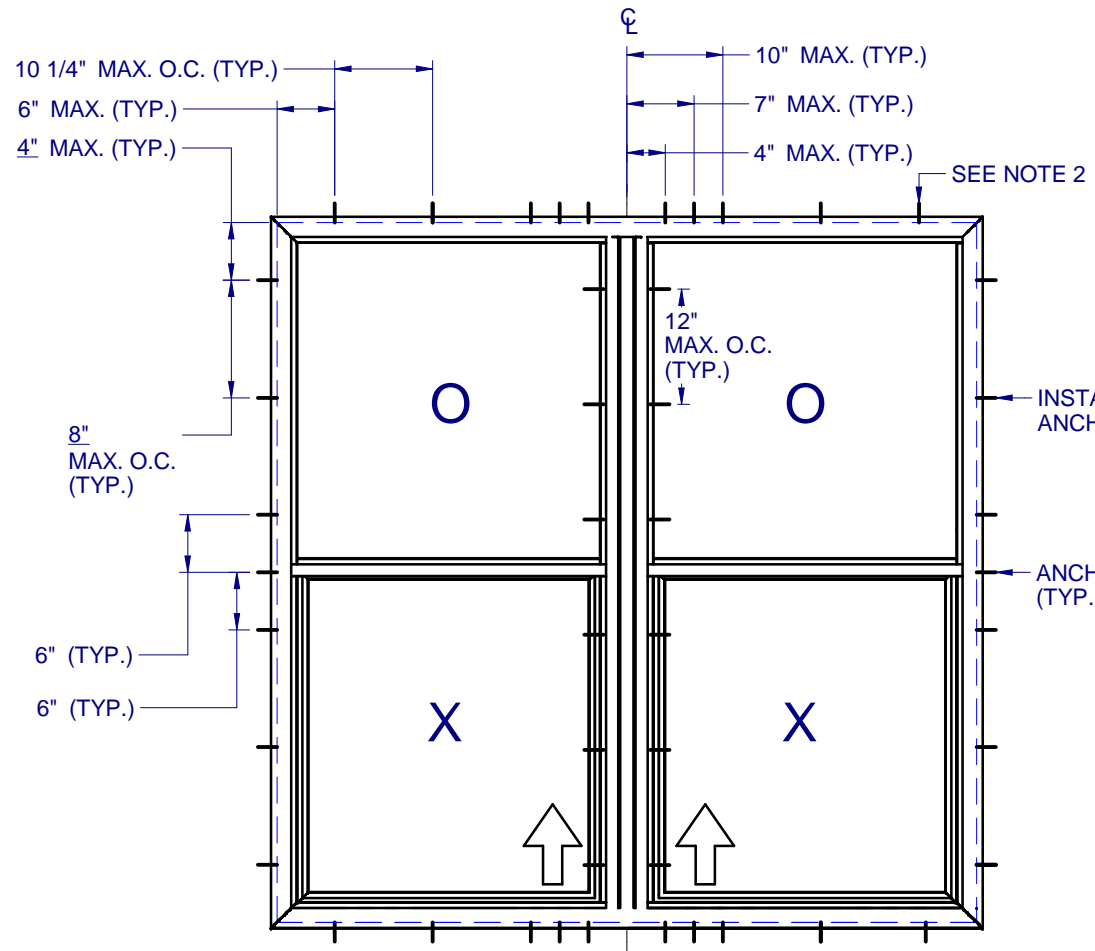

ANCHOR LAYOUT - (FLANGE)

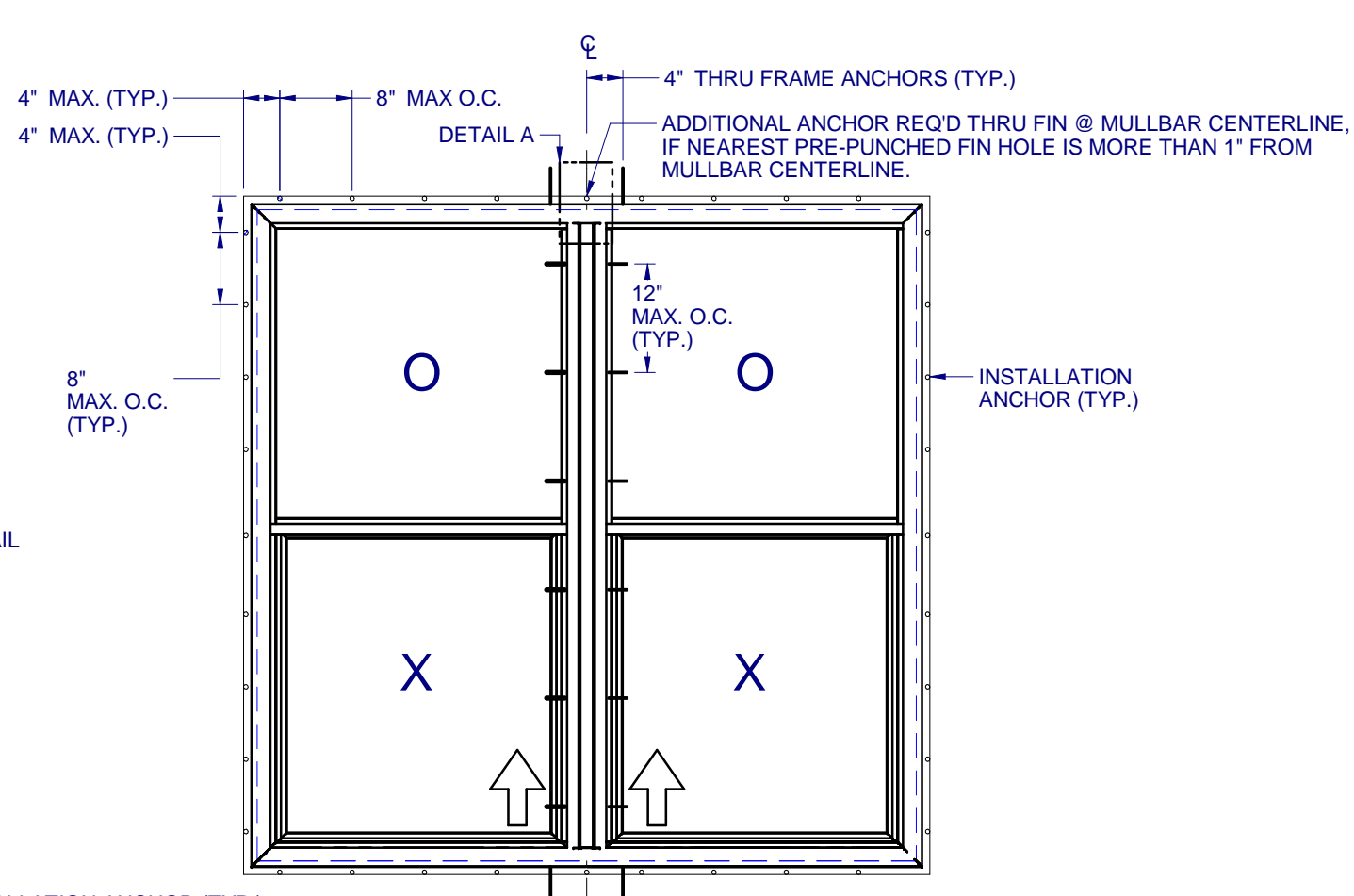

ANCHOR LAYOUT - (FIN)

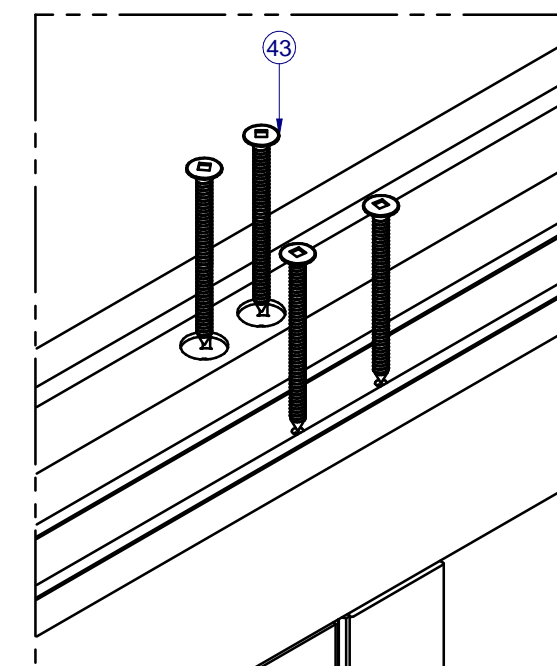

DETAIL A
INTERNAL MULL ATTACHMENT

- NOTES:
- INSTALL ONE ANCHOR AT EACH INSTALLATION LOCATION. SILL ANCHOR SPACING SAME AS HEAD. SEAL CORNERS AND INTERNAL MULL WITH SMALL JOINT SEAM SEALANT.
 - SHIM AS REQ AT EACH INSTALLATION ANCHOR USING LOAD BEARING SHIMS. MAX. ALLOWABLE SHIM STACK TO BE 1/4". USE SHIMS WHERE SPACE GREATER THAN 1/16" IS PRESENT. LOAD BEARING SHIMS SHALL BE CONSTRUCTED OF HIGH DENSITY PLASTIC OR BETTER. WOOD SHIMS ARE NOT ALLOWED.
 - ANCHOR TYPE, SIZE, SPACING AND EMBEDMENT SHALL BE AS SPECIFIED IN THESE DRAWINGS, SEE TABLE 1, SHEET 6.
 - ALL INSTALLATION ANCHORS MUST BE MADE OF OR PROTECTED WITH A CORROSION RESISTANT MATERIAL OR COATING. DISSIMILAR METALS OR MATERIALS IN CONTACT WITH PRESSURE TREATED WOOD MUST BE PROTECTED TO PREVENT REACTION.
 - INSTALLATION ANCHORS SHALL BE IN ACCORDANCE WITH ANCHOR MANUFACTURER'S INSTALLATION INSTRUCTIONS, AND ANCHORS SHALL NOT BE USED IN SUBSTRATES WITH STRENGTHS LESS THAN THE MINIMUM SPECIFIED IN TABLE 1, SHEET 6.
 - ANCHOR EMBEDMENT TO SUBSTRATE SHALL BE BEYOND WALL DRESSING OR STUCCO. FOR CONCRETE/CMU OPENINGS, EMBEDMENT SHALL BE BEYOND WOOD BUCKS, IF USED, INTO SUBSTRATE - 1X BUCKS ARE OPTIONAL.
 - A MINIMUM CENTER-TO-CENTER SPACING SHALL BE MAINTAINED BETWEEN ALL FASTENERS: 3" FOR MASONRY, 1" FOR WOOD AND METAL.
 - WOOD OR MASONRY OPENINGS, BUCKS AND BUCK FASTENERS SHALL BE PROPERLY DESIGNED BY THE ARCHITECT OR ENGINEER OF RECORD AND INSTALLED TO TRANSFER WIND LOADS TO THE STRUCTURE. SUBSTRATES SHALL MEET THE MINIMUM STRENGTH REQUIREMENTS AS SHOWN IN TABLE 1, SHEET 6. CONCRETE AND MASONRY SUBSTRATES MAY NOT BE CRACKED.
 - SEALING AND FLASHING STRATEGIES FOR OVERALL WATER RESISTANCE OF INSTALLATION SHALL BE DONE BY OTHERS FOLLOWING THE CURRENT VERSION OF THE REFERENCE DOCUMENTS: FMA/AAMA 100(FIN WINDOWS), FMA/AAMA 200(FLANGE WINDOWS), FMA/WDMA 250(BOX WINDOWS), FMA/AAMA/WDMA 300(EXTERIOR DOORS)

**8100 PVC
SINGLE HUNG
NON-IMPACT**

NO.	DESCRIPTION:	BY:	DATE:
C	REVISED TO TDI REQUEST	MS	12/14/21
B	REVISED TO TDI REQUEST	JML	3/20/17
A	REVISED TO TDI REQUEST	JML	8/2/16

REVISIONS



1/14/2021

LUCAS A. TURNER, P.E.
TX PE # 115094
2428 OLD NATCHEZ TRC TRL
CAMDEN, TN 38320
PH. 941-380-1574

SHEET DESCRIPTION:
INSTALLATION DETAILS

DRAWN BY: EMK	DATE: 11/10/15
DWG #: TDI-492	REV.: C
SCALE: 1:2	SHEET 6 OF 6

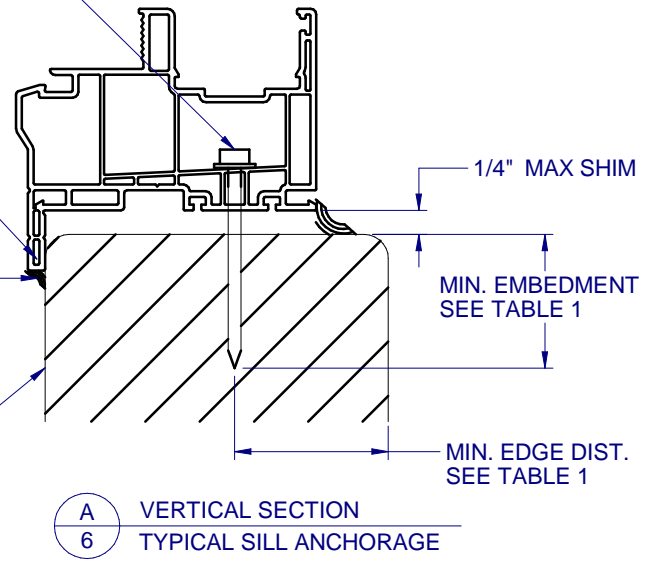
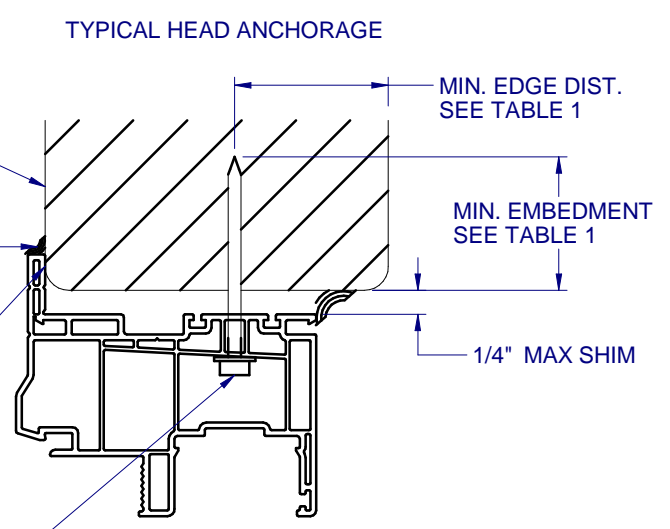

A
6 VERTICAL SECTION
TYPICAL SILL ANCHORAGE

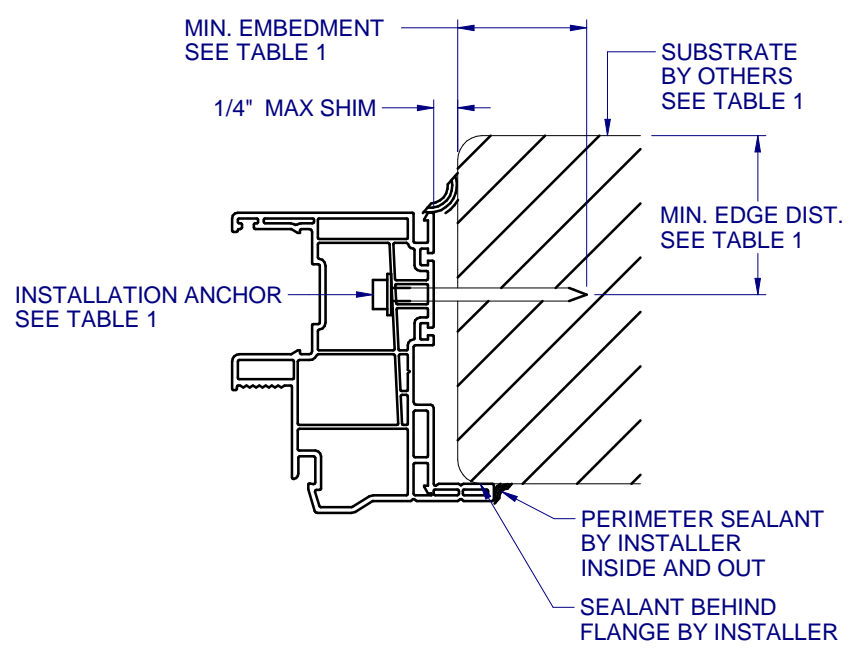

B
6 HORIZONTAL SECTION
TYPICAL JAMB ANCHORAGE

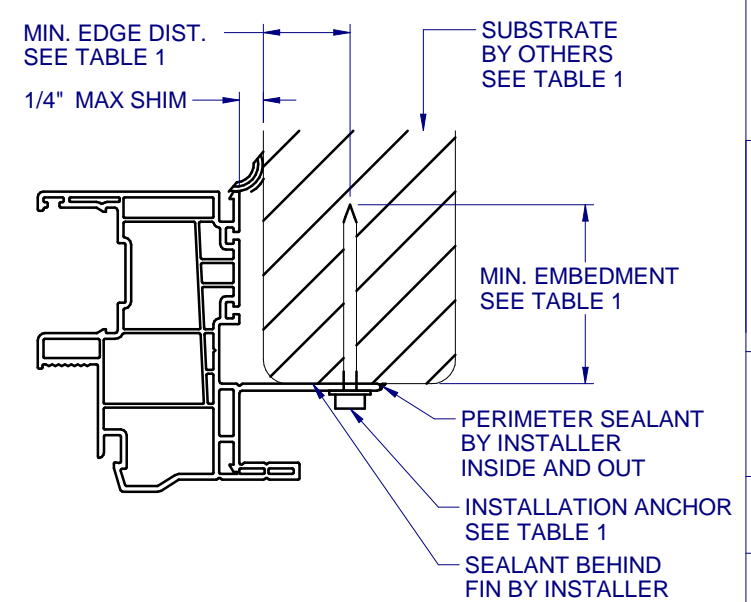

C
6 HORIZONTAL SECTION
TYPICAL FIN ANCHORAGE
HEAD AND SILL SIMILAR FOR FIN INSTALLATION

NOTE: ADDITIONAL THRU-FRAME ANCHORS (AS SHOWN IN DET. A/6) REQ'D AT THE HEAD AND SILL AT MULLION, SEE SHEET 5 ANCHOR LAYOUT.

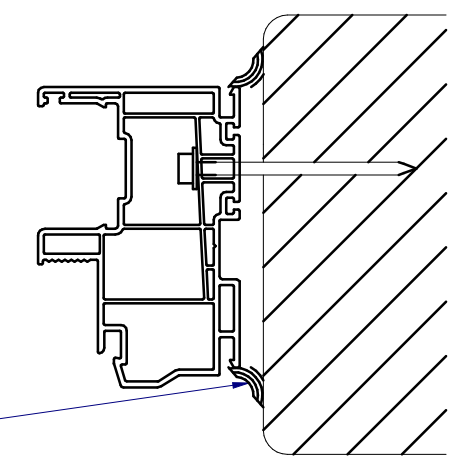

D
6 HORIZONTAL SECTION
BOX FRAME INSTALLATION
SIMILAR FOR SILL AND JAMBS FOR BOX INSTALLATION

FLANGE REMOVAL NOTE: PARTIALLY OR FULLY REMOVING THE FLANGE, UP TO AND INCLUDING A BOX-FRAME APPLICATION IS ACCEPTABLE PROVIDED:

- MIN. 1/4" FILLET OF CONSTRUCTION-GRADE ADHESIVE CAULK IS APPLIED INSIDE AND OUT, FULL PERIMETER, BY INSTALLER.
- PRODUCT ANCHORAGE IS IN ACCORDANCE WITH REQUIREMENTS AS SHOWN FOR FLANGE WINDOWS.

TABLE 1: APPROVED INSTALLATION FASTENERS

FRAME TYPE	SUBSTRATE TYPE	ANCHOR TYPE	MIN. EMBEDMENT	MIN. EDGE DIST.
FLANGE	CONCRETE (2.0 KSI MIN.)	3/16" ITW TAPCON	1"	1-1/8"
FLANGE	HOLLOW OR GROUT-FILLED CMU (117 PCF MIN.)	3/16" ITW TAPCON	1"	2"
FLANGE	CONCRETE (2.85 KSI MIN.)	3/16" ELCO ULTRACON	1"	1"
FLANGE	GROUT-FILLED CMU (ASTM C-90)	3/16" ELCO ULTRACON	1-1/4"	2-1/2"
FLANGE	2X MIN. SOUTHERN PINE (G=0.55)	3/16" ITW TAPCON OR ELCO ULTRACON	1-3/8"	7/8"
FLANGE	2X MIN. SOUTHERN PINE (G=0.55)	#10 WOOD SCREW	1-3/8"	7/8"
FLANGE	16 GAUGE (0.060") MIN. STEEL STUD (33 KSI YIELD MIN)	#10-16 HILTI KWIK-FLEX OR ITW TEKS SELF-DRILLING SCREW	FULL THREAD THRU 0.060"	7/16"
FLANGE	1/8" ALUM. (6063-T5 MIN.) OR 1/8" STEEL (33 KSI MIN.)	#10 GRADE 5 SELF-TAPPING / DRILLING SCREW	FULL THREAD THRU 0.125"	7/16"
FIN	2X MIN. SOUTHERN PINE (G=0.55)	#8 WOOD SCREW	1-1/2"	7/16"