

WINCORE™

WINDOWS & DOORS

250 Staunton Turnpike, Parkersburg, WV 26104

8400 Series Vinyl Outswing Casement Window "NON-IMPACT"

EVALUATED FOR USE IN THE STATE OF TEXAS

TDI WIN-1748

The Wincore Casement Window described herein complies with the 2018 International Residential Code (IRC), Sections R301 & R609 and the 2018 International Building Code (IBC), Sections 1404.13, 1609, 1709.5, 2403 and 2404 subject to the following conditions:

1. Anchors shall be as listed and spaced as shown in the details. Anchor embedment to base material shall be beyond wall dressing or stucco.
2. When used in areas requiring wind-borne debris protection this product is required to be protected with an impact resistant covering that complies with Section R301.2.1.2 of the IRC and Section 1609.1.2 of the IBC.
3. Allowable design pressure requirements must be equal to or less than the design pressure rating shown in the design pressure chart, sheet 1 of this drawing.
4. Conditions not covered by this drawing are subject to further engineering analysis.

TABLE OF CONTENTS	
SHEET#	DESCRIPTION
1	Typical elevations, design pressures and general notes
2	Vertical & horizontal cross sections
3	Frame anchoring
4	Bill of materials, components and glazing details

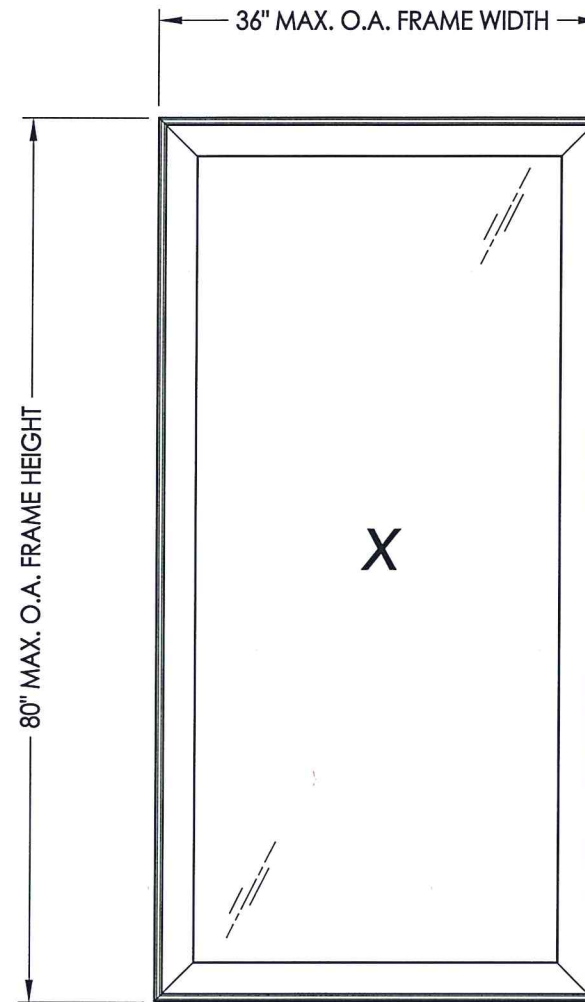

MAX. FRAME DIMENSION	MAX. D.L.O. DIMENSION	GLASS TYPE	DESIGN PRESSURE (PSF)	
			POSITIVE	NEGATIVE
36.0" X 80.0"	29.5" X 73.5"	G1	+50.0	-50.0
36.0" X 80.0"	29.5" X 73.5"	G2	+65.0	-75.0

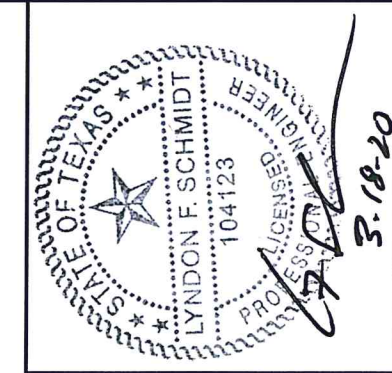

Documents Prepared By: Lyndon F. Schmidt, P.E.
TEXAS P.E. #104123

RW BUILDING CONSULTANTS, INC.
P.O. Box 230 Valrico FL 33595
Phone No.: 813.659.9197
TEXAS BOARD OF PROFESSIONAL ENGINEERS
CERTIFICATE OF REGISTRATION # F-11852

PRODUCT: 8400 SERIES Vinyl Outswing Casement Window
PART OR ASSEMBLY: TYPICAL ELEVATION, DESIGN PRESSURES & GENERAL NOTES

NO.	DATE	BY	REVISIONS
2	1/20/20	LFS	UPDATE TO 2018 IRC/IRC
1	8/27/13	JK	ADDED NEW GLAZING/D.P.

DATE: 9/10/12
SCALE: N.T.S.
DWG. BY: JK
CHK. BY: LFS
DRAWING NO.: TX-4242
SHEET 1 OF 4

NOTE:
 1. Multi-point locks/keepers (4) located at 5.5", 27.5", 50.5" and 73.5" from the bottom of sash.

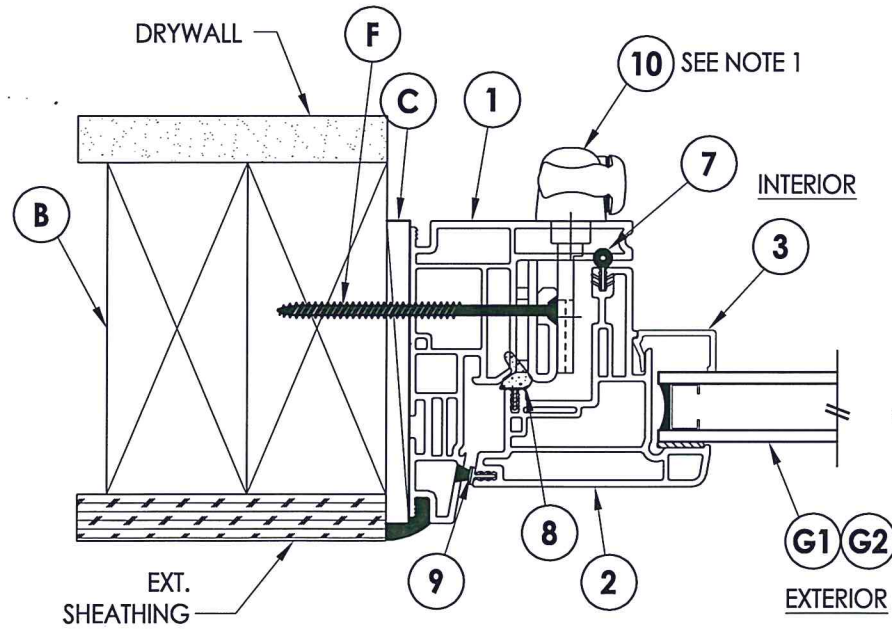
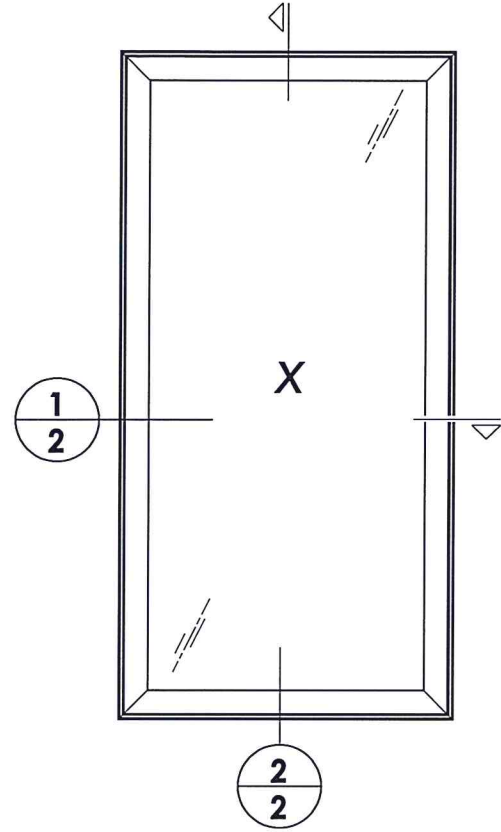

1
2 HORIZONTAL CROSS SECTION

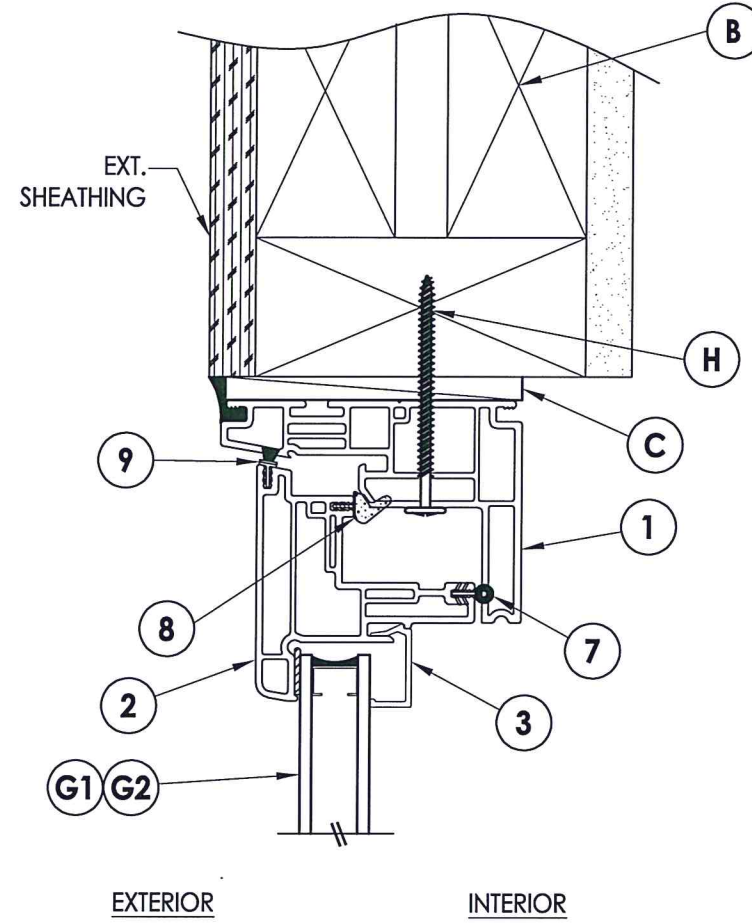
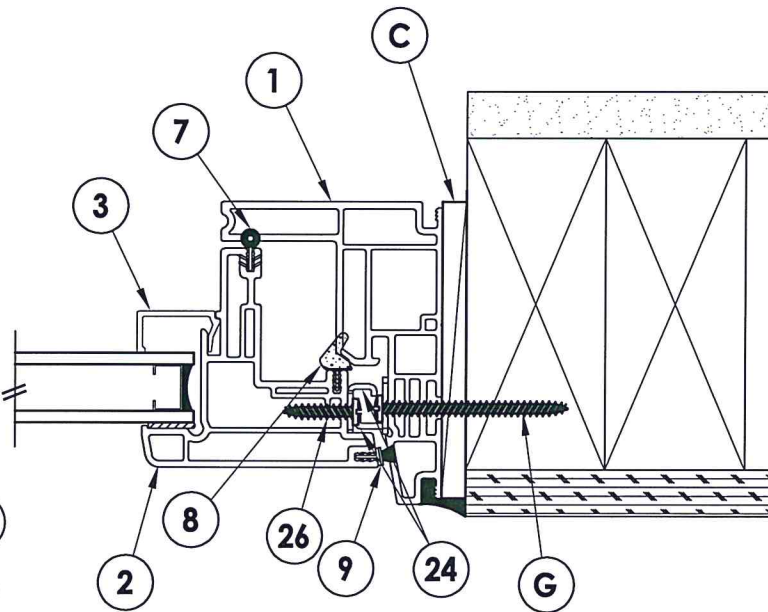

2
2 VERTICAL CROSS SECTION

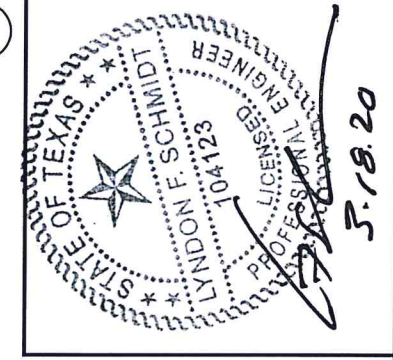
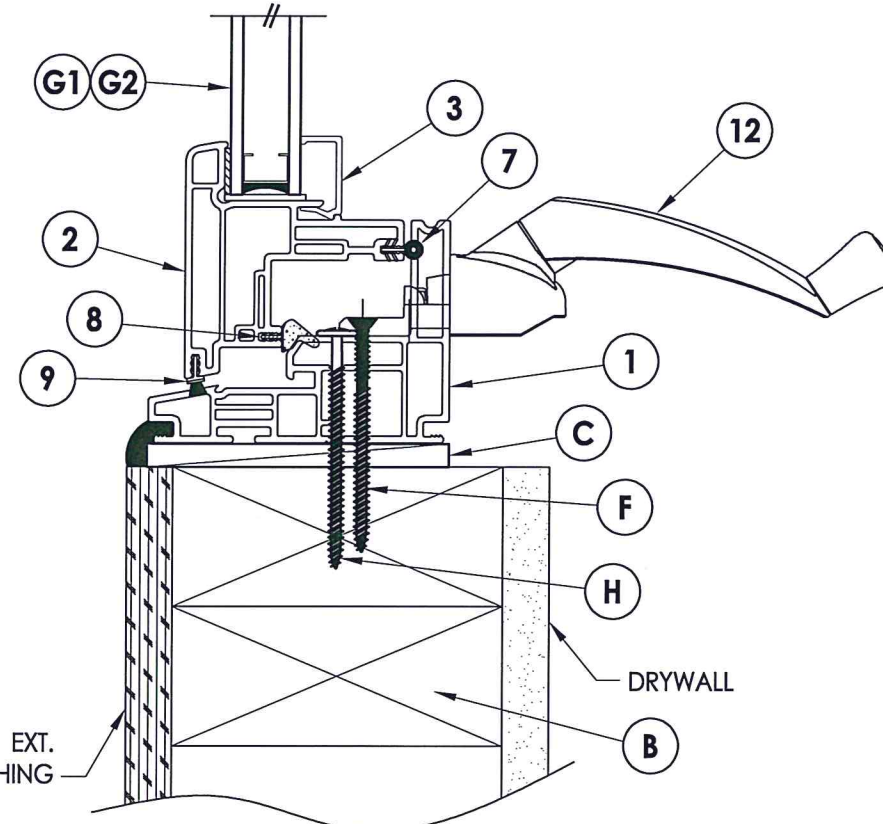

Documents Prepared By: Lyndon F. Schmidt, P.E.
 TEXAS P.E. #104123

RW BUILDING CONSULTANTS, INC.
 P.O. Box 230 Volrico FL 33595
 Phone No.: 813.659.9197

TEXAS BOARD OF PROFESSIONAL ENGINEERS
 CERTIFICATE OF REGISTRATION # F-11852

PRODUCT: 8400 SERIES
 Vinyl Outswing Casement Window

PART OR ASSEMBLY:
 VERTICAL AND HORIZONTAL
 CROSS SECTIONS

NO.	DATE	REVISIONS
2	1/20/20	UPDATE TO 2018 IBC/IRC
1	8/27/13	ADDED NEW GLAZING/D.P.

DATE: 9/10/12
 SCALE: N.T.S.
 DWG. BY: JK
 CHK. BY: LFS
 DRAWING NO.: TX-4242
 SHEET 2 OF 4

R:\Clients\Wincore PERMANENT\B - (2018) Texas Dept of Ins\WIN 1748 - Casement 8400\C - Drawings\2018 IBC UPDATE\TX-4242.dwg, 3.1

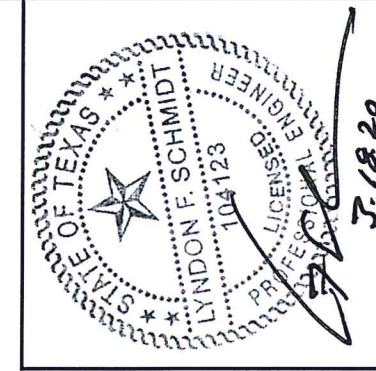
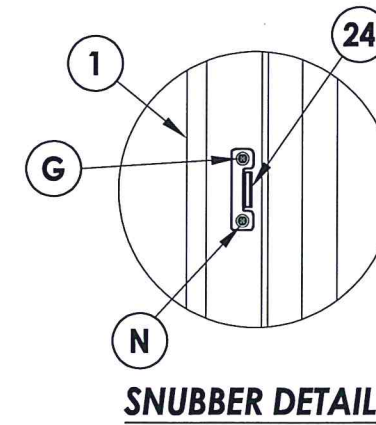
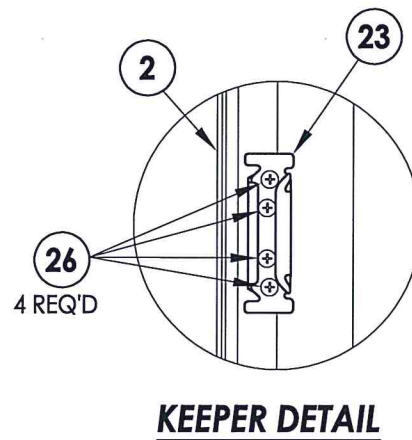
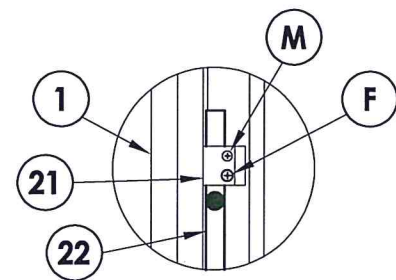
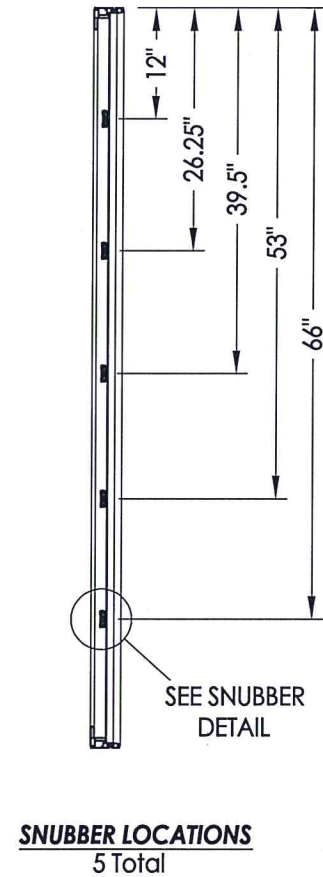
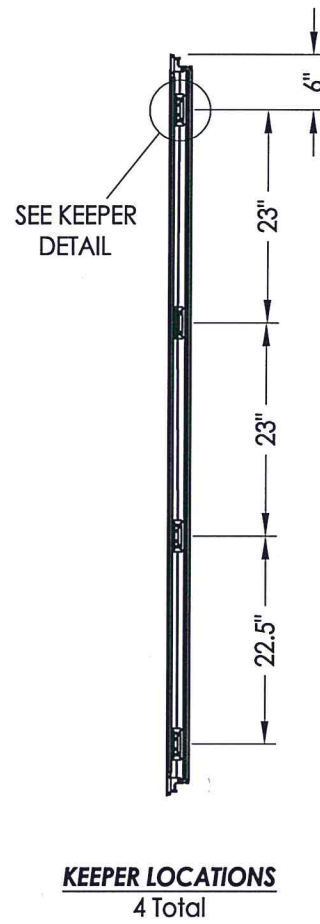
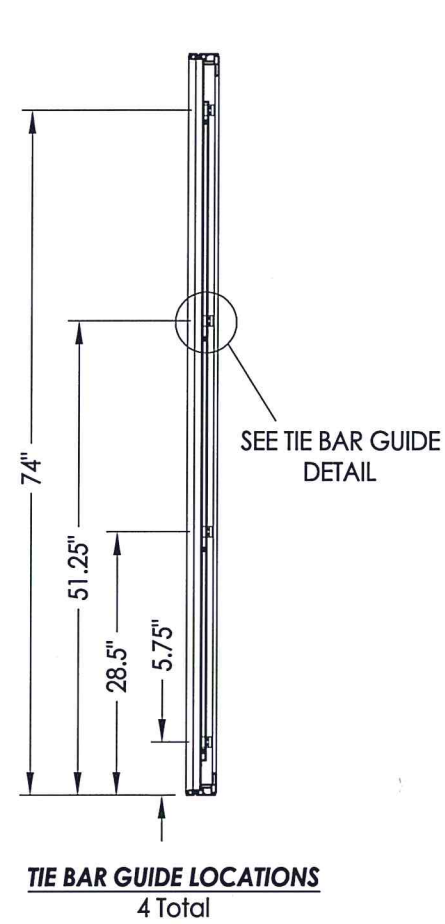
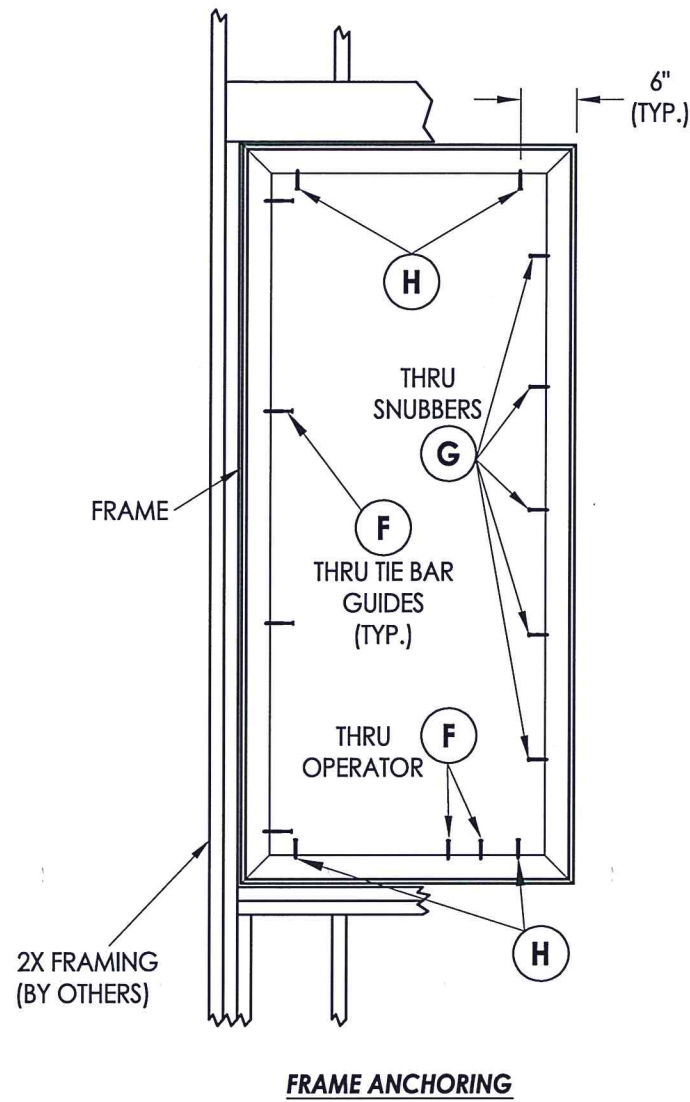

Documents Prepared By: Lyndon F. Schmidt, P.E.
TEXAS P.E. #104123

RW BUILDING CONSULTANTS, INC.
P.O. Box 230 Valrico FL 33595
Phone No.: 813.659.9197

TEXAS BOARD OF PROFESSIONAL ENGINEERS
CERTIFICATE OF REGISTRATION # F-11852

NO.	DATE	REVISIONS
2	1/20/20	UPDATE TO 2018 IBC/IRC
1	8/27/13	ADDED NEW GLAZING/D.P.

DATE: 9/10/12
SCALE: N.T.S.
DWG. BY: JK
CHK. BY: LFS
DRAWING NO.: TX-4242
SHEET 3 OF 4

PRODUCT: 8400 SERIES Vinyl Outswing Casement Window
PART OR ASSEMBLY: FRAME ANCHORING

BY: JK

© 2012 R.W. BUILDING CONSULTANTS INC.

BILL OF MATERIALS

ITEM #	DESCRIPTION	MATERIAL
B	2X FRAMING (SG >= 0.42)	WOOD
C	1/4" MAX. SHIM SPACE	-
F	#8 X 3" FH WOOD SCREW (1-1/4" MIN. EMB. @ JAMB, 7/8" @ SILL)	STEEL
G	#8 X 2" PH WOOD SCREW (1-1/8" MIN. EMBEDMENT)	STEEL
H	#8 X 2-1/2" MODIFIED TRUSS HEAD WOOD SCREW (1-1/8" MIN. EMBEDMENT)	STEEL
M	#8 X 1" PFH WOOD SCREW	STEEL
N	#8 X 3/4" PPH SMS	STEEL
1	FRAME*	PVC
2	SASH*	PVC
3	GLAZING BEAD*	PVC
7	WEATHERSTRIP AMESBURY (CS 120 33-SEAL)	FOAM
8	WEATHERSTRIP AMESBURY (12300 SEAL)	VINYL
9	WEATHERSTRIP ULTRA FAB .250 (PILE - 250 - KP52)	VINYL
10	MULTI-POINT LOCK (TRUTH) W1495-20	-
12	OPERATOR (TRUTH) 2003587	-
21	TIE BAR GUIDE (TRUTH) 2008741	-
22	TIE BAR (TRUTH) WCMS4734003	-
23	KEEPER (TRUTH) W1495-01W11	-
24	SNUBBER (TRUTH) (SASH/FRAME) WCS1-1496-85	-
26	#8 X 3/4" PFH SMS	S.S.

* THE APPROVED WHITE RIGID PVC EXTERIOR EXTRUSIONS FOR WINDOWS ARE TO BE PRODUCED BY EXTRUDERS LICENSEES IN "CERTIFICATION PROGRAMS FOR RIGID PVC EXTRUSIONS".

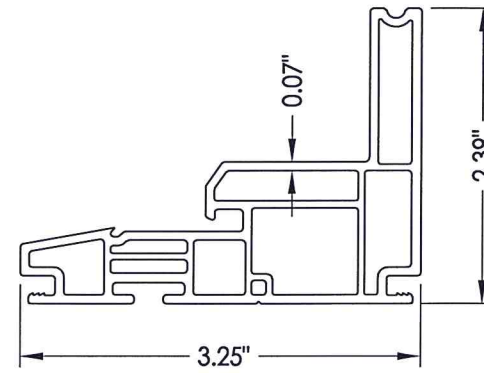

1 FRAME

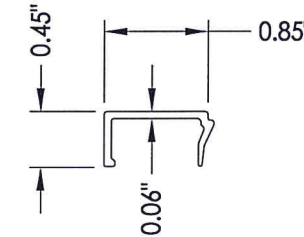

3 GLAZING BEAD

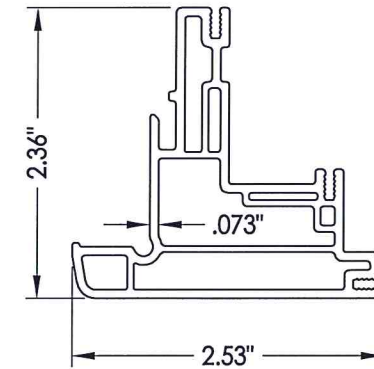

2 SASH

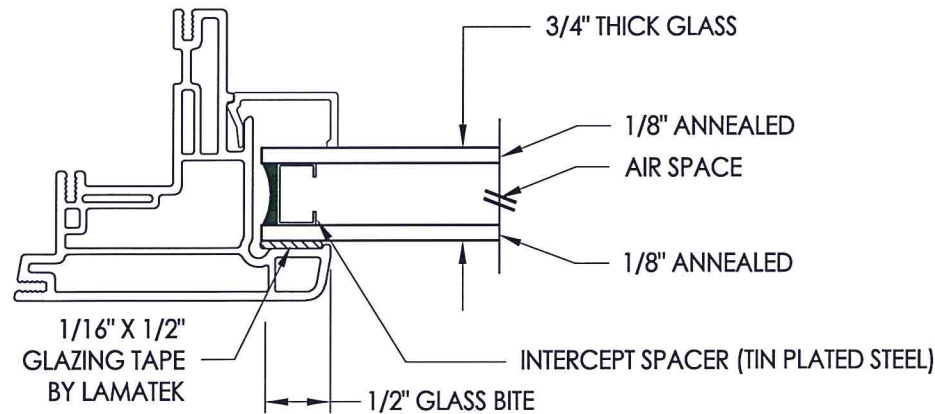
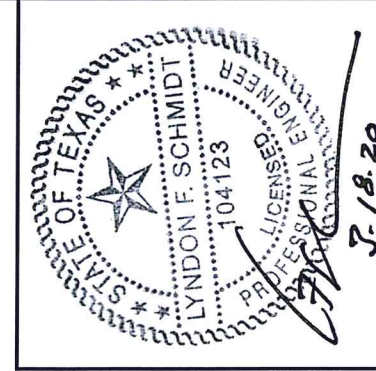

G1 GLAZING DETAIL

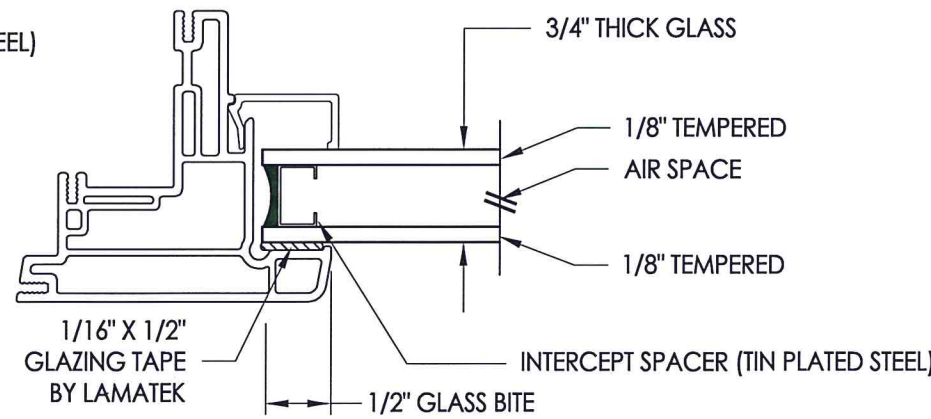

G2 GLAZING DETAIL

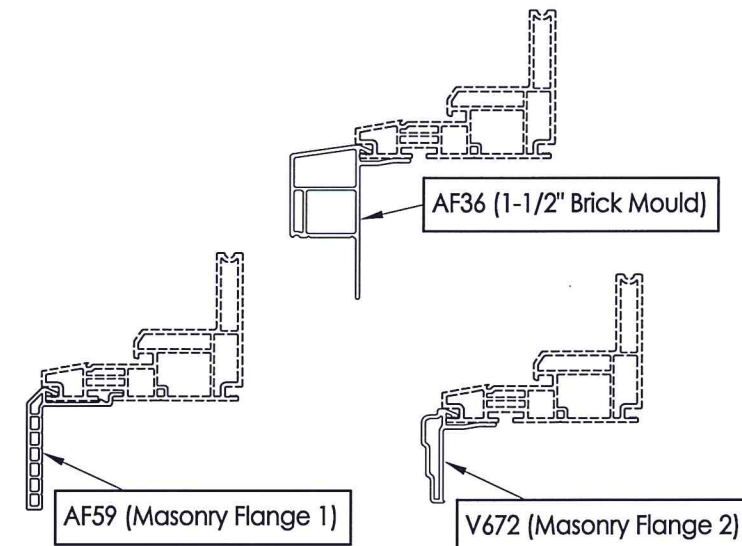

OPTIONAL COSMETIC FLANGES

Documents Prepared By: Lyndon F. Schmidt, P.E. TEXAS P.E. #104123

RW BUILDING CONSULTANTS, INC.
P.O. Box 230 Valrico FL, 33595
Phone No.: 813.659.9197

TEXAS BOARD OF PROFESSIONAL ENGINEERS
CERTIFICATE OF REGISTRATION # F-11852

PRODUCT: 8400 SERIES Vinyl Outswing Casement Window

PART OR ASSEMBLY: BILL OF MATERIALS, COMPONENTS AND GLAZING DETAIL

NO.	DATE	REVISIONS
2	1/20/20	UPDATE TO 2018 IBC/IRC
1	8/27/13	UPDATED D.P./GLAZING

DATE: 9/10/12
SCALE: N.T.S.
DWG. BY: JK
CHK. BY: LFS
DRAWING NO.: TX-4242
SHEET 4 OF 4

© 2012 R.W. BUILDING CONSULTANTS INC.