

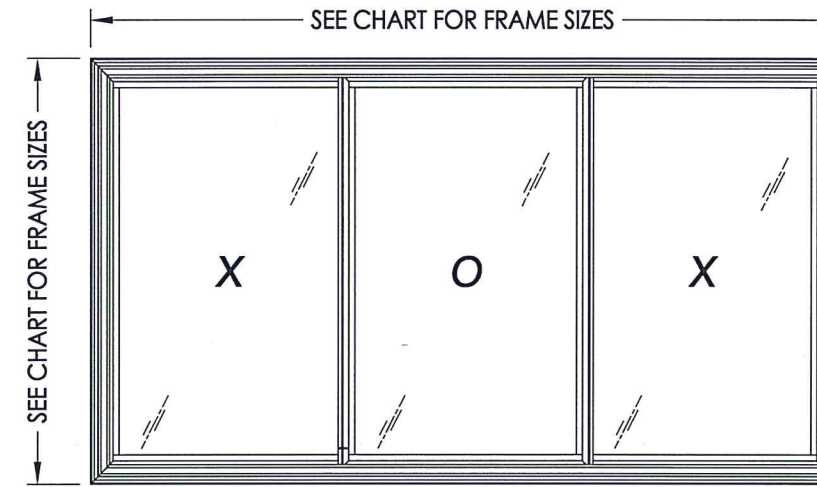

Bringing quality to light.

10250 Philipp Parkway  
Streetsboro, Ohio 44241

# "BARCELONA" Model "TSL30" HORIZONTAL SLIDING WINDOW "NON-IMPACT"



1/3 - 1/3 - 1/3

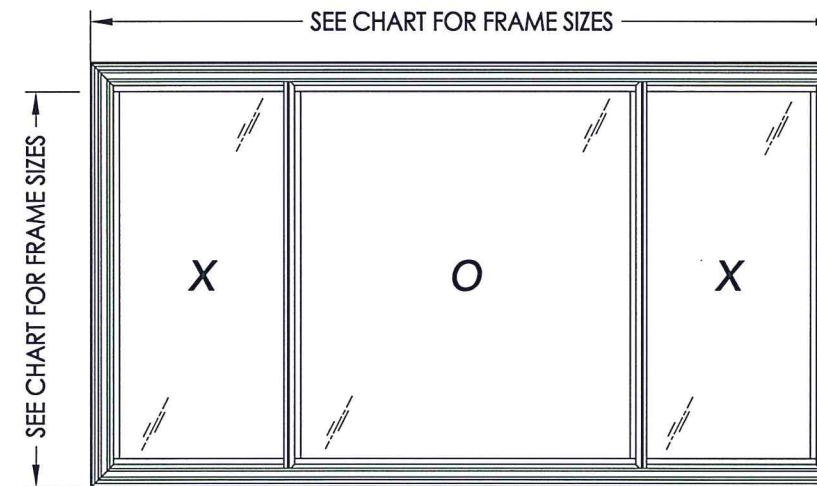

1/4 - 1/2 - 1/4

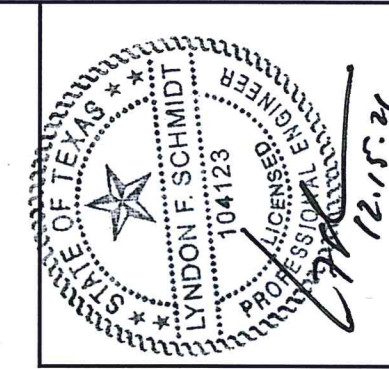

Documents Prepared By: Lyndon F. Schmidt, P.E.  
TEXAS P.E. #104123

**RW** BUILDING CONSULTANTS, INC.  
P.O. Box 230 Valrico FL 33595  
Phone No.: 813.659.9197

TEXAS BOARD OF PROFESSIONAL ENGINEERS  
CERTIFICATE OF REGISTRATION # F-11852

EVALUATED FOR USE IN THE STATE OF TEXAS

### TDI WIN-2403

The Horizontal Sliding Window described herein complies with the 2018 International Residential Code (IRC), Sections R301 & R609 and the 2018 International Building Code (IBC), Sections 1404.13, 1609, 1709.5, 2403 and 2404 subject to the following conditions:

1. Anchors shall be as listed and spaced as shown in the details. Anchor embedment to base material shall be beyond wall dressing or stucco.
2. When used in areas requiring wind-borne debris protection this product is required to be protected with an impact resistant covering that complies with Section R301.2.1.2 of the IRC and Section 1609.2 of the IBC.
3. Allowable design pressure requirements must be equal to or less than the design pressure rating shown in the design pressure chart, sheet 1 of this drawing.
4. Conditions not covered by this drawing are subject to further engineering analysis.

TABLE OF CONTENTS	
SHEET#	DESCRIPTION
1	Typical elevations, design pressures & general notes
2	Horizontal cross sections
3	Vertical cross sections
4	Buck and frame anchoring
5	Components
6	Bill of materials & glazing details

CONFIGURATION	MAX. FRAME DIMENSION	MAX. D.L.O. DIMENSION	GLASS TYPE	DESIGN PRESSURE (PSF)	
				POSITIVE	NEGATIVE
1/3 - 1/3 - 1/3	111.0" X 63.0"	32.75" x 54.25"	G1	+40.0	-40.0
1/3 - 1/3 - 1/3	111.0" X 63.0"	32.75" x 54.25"	G2	+25.0	-25.0
1/4 - 1/2 - 1/4	111.0" X 63.0"	24.25" x 54.25" 49.75" x 54.25"	G1	+40.0	-40.0
1/4 - 1/2 - 1/4	111.0" X 63.0"	24.25" x 54.25" 49.75" x 54.25"	G2 G1	+25.0	-25.0
1/3 - 1/3 - 1/3	96.0" X 44.0"	27.75" x 35.25"	G1	+50.0	-50.0
1/3 - 1/3 - 1/3	96.0" X 44.0"	27.75" x 35.25"	G2	+35.0	-35.0
1/4 - 1/2 - 1/4	96.0" X 44.0"	20.5" x 35.25" 42.25" x 35.25"	G1	+45.0	-45.0
1/4 - 1/2 - 1/4	96.0" X 44.0"	20.5" x 35.25" 42.25" x 35.25"	G2	+30.0	-30.0

PRODUCT:	SOFT-LITE WINDOWS
PART OR ASSEMBLY:	TYPICAL ELEVATION, DESIGN PRESSURES & GENERAL NOTES
NO.	1
DATE	5/11/21
UPDATE TO	2018 IBC/IRC
BY	LFS
REVISIONS	
DATE:	6/26/18
SCALE:	N.T.S.
DWG. BY:	JK
CHK. BY:	LFS
DRAWING NO.:	TX-4857
SHEET	1 OF 6

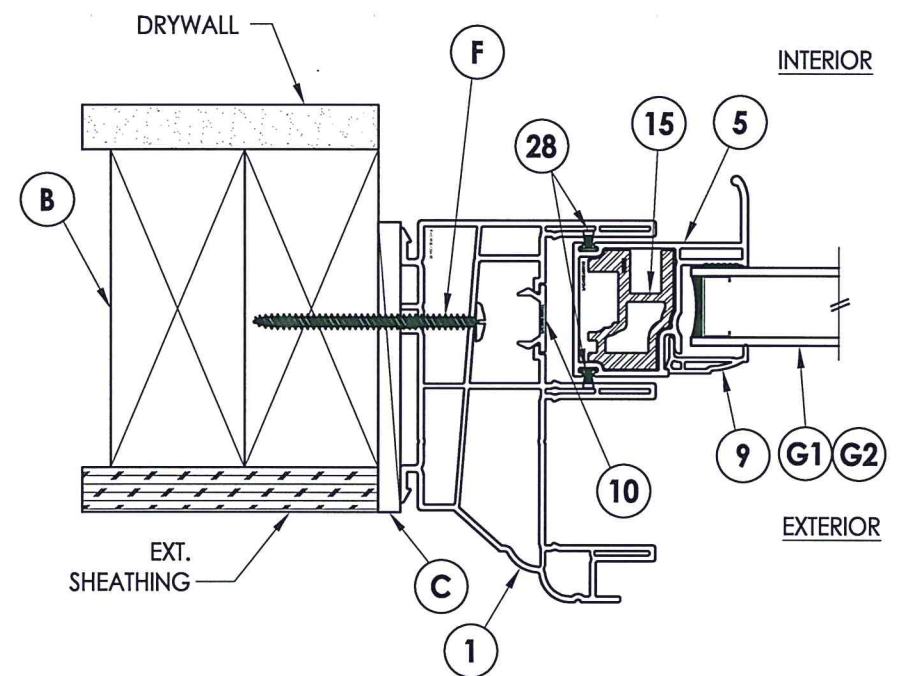
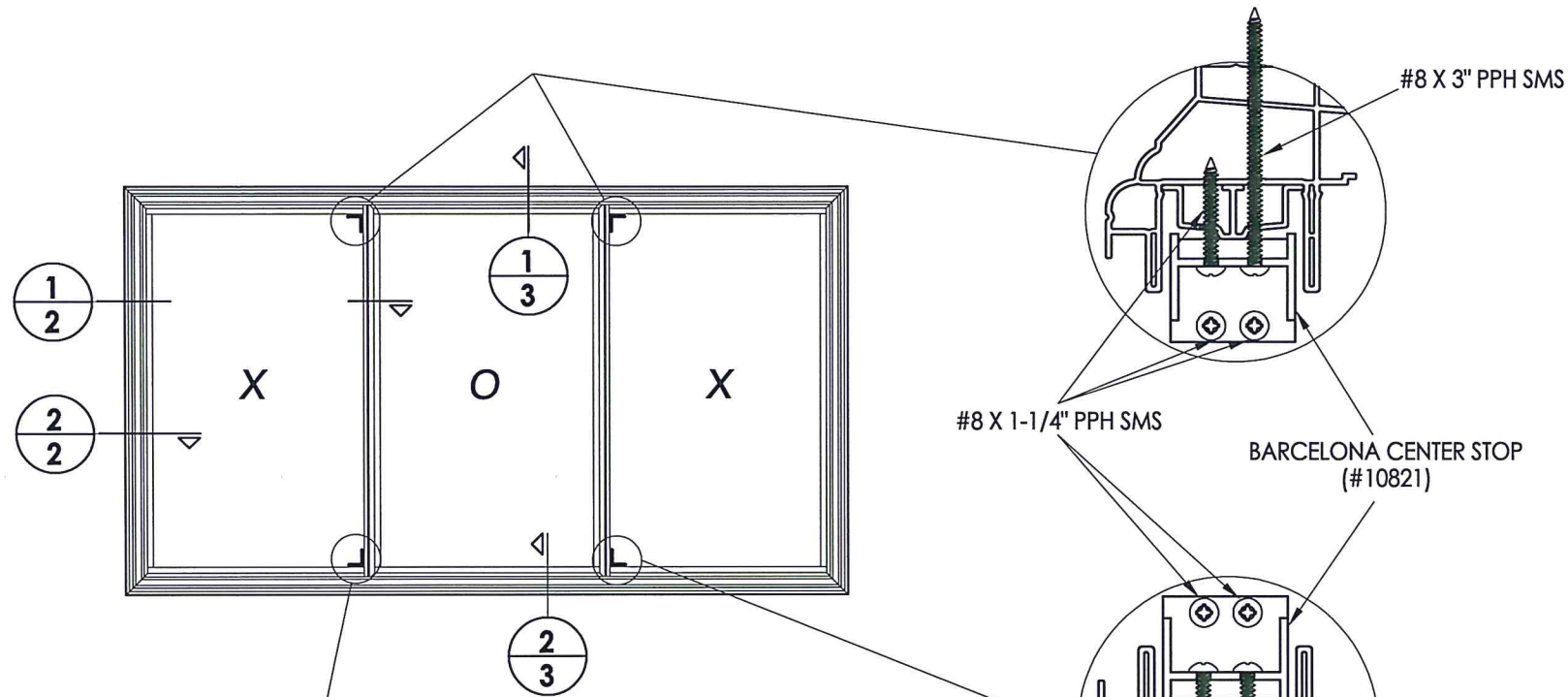

**2 HORIZONTAL CROSS SECTION**  
Shown w/ Stud Framing

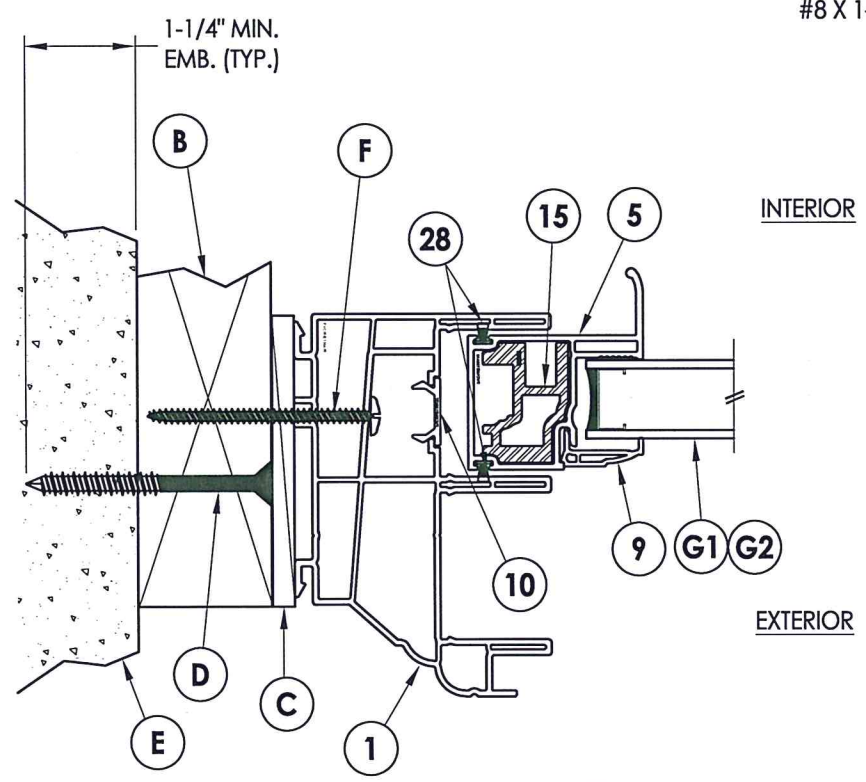

**1 HORIZONTAL CROSS SECTION**  
2X Buck Construction

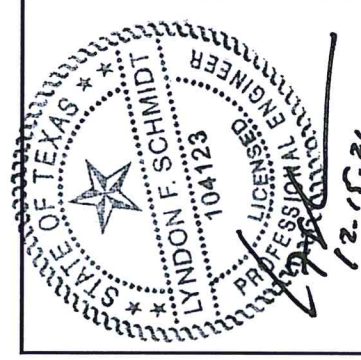
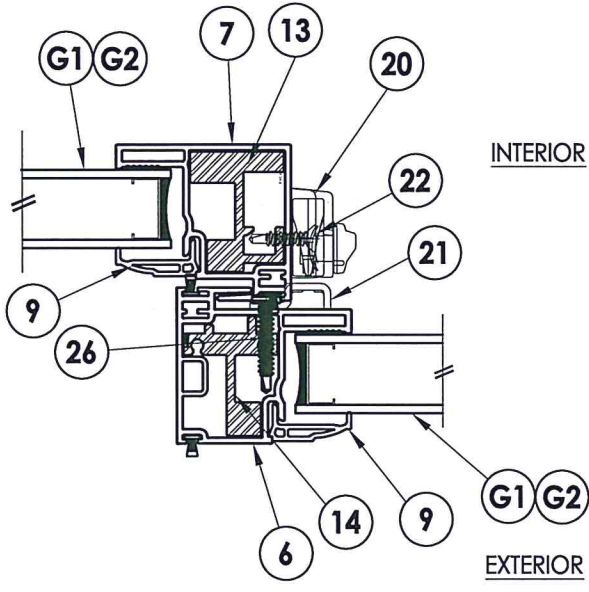

Documents Prepared By: Lyndon F. Schmidt, P.E.  
TEXAS P.E. #104123

**RW** BUILDING CONSULTANTS, INC.  
P.O. Box 230 Valrico FL, 33595  
Phone No.: 813.659.9197

TEXAS BOARD OF PROFESSIONAL ENGINEERS  
CERTIFICATE OF REGISTRATION # F-11852

PRODUCT:	SOFT-LITE WINDOWS	
PART OR ASSEMBLY:	HORIZONTAL CROSS SECTIONS	
NO.	DATE	BY
1	5/11/21	LFS
UPDATE TO 2018 IBC/IRC		
REVISIONS		
DATE:	6/26/18	
SCALE:	N.T.S.	
DWG. BY:	JK	
CHK. BY:	LFS	
DRAWING NO.:	TX-4857	
SHEET	2	OF 6

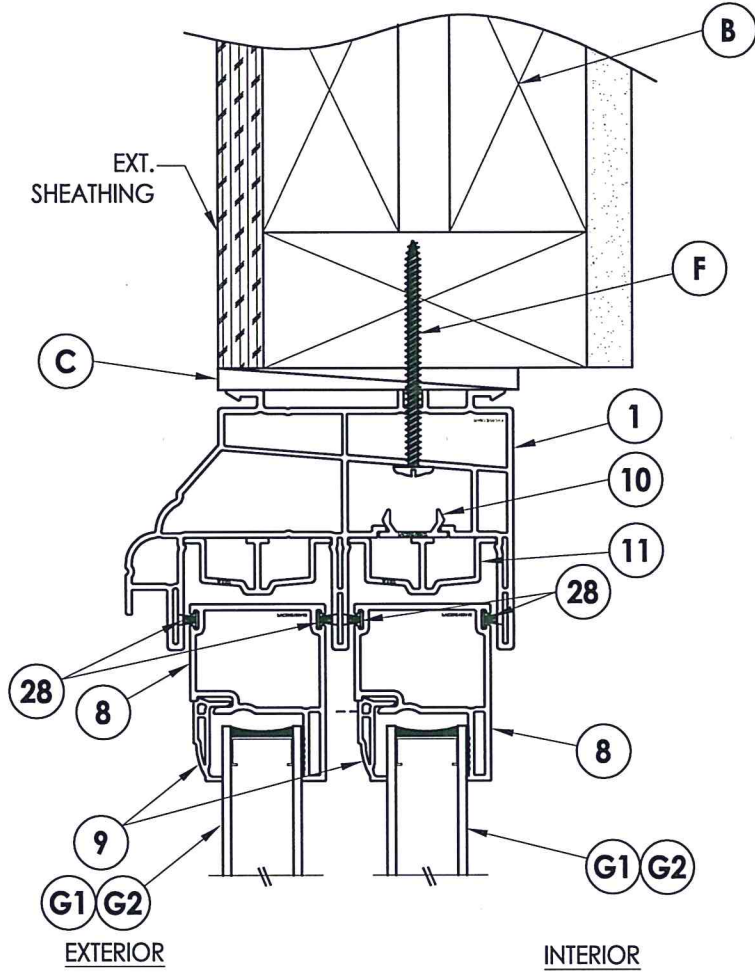

**1 VERTICAL CROSS SECTION**  
**3** Shown w/ Stud Framing

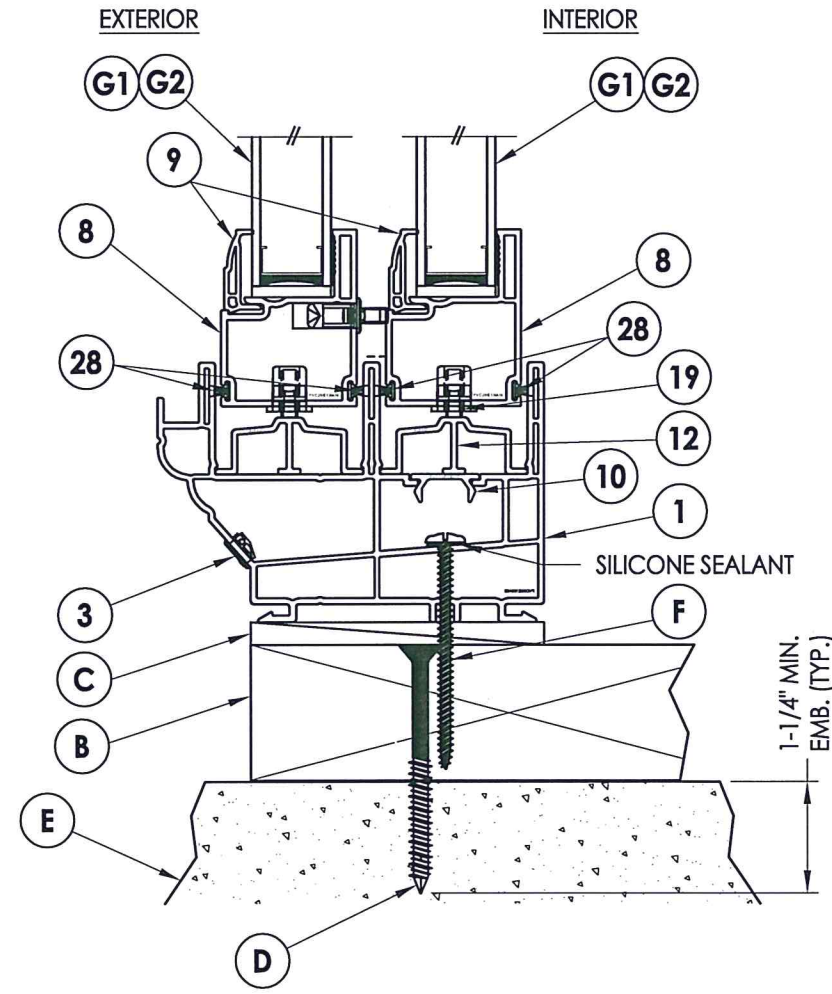

**2 VERTICAL CROSS SECTION**  
**3** 2X Buck Construction

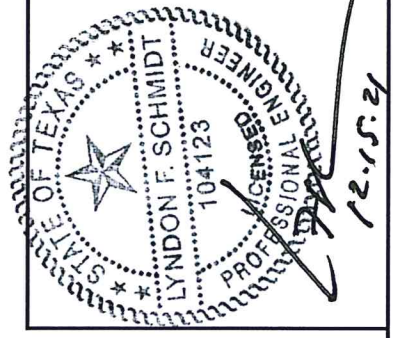

Documents Prepared By: Lyndon F. Schmidt, P.E.  
 TEXAS P.E. #104123

**RW** BUILDING CONSULTANTS, INC.  
 P.O. Box 230 Valrico FL, 33595  
 Phone No.: 813.659.9197

TEXAS BOARD OF PROFESSIONAL ENGINEERS  
 CERTIFICATE OF REGISTRATION # F-11852

PRODUCT:	SOFT-LITE WINDOWS	
PART OR ASSEMBLY:	VERTICAL CROSS SECTIONS	
NO.	DATE	BY
1	5/11/21	LFS
UPDATE TO 2018 IBC/IRC		
REVISIONS		
DATE:	6/26/18	
SCALE:	N.T.S.	
DWG. BY:	JK	
CHK. BY:	LFS	
DRAWING NO.:	TX-4857	
SHEET	3	OF 6

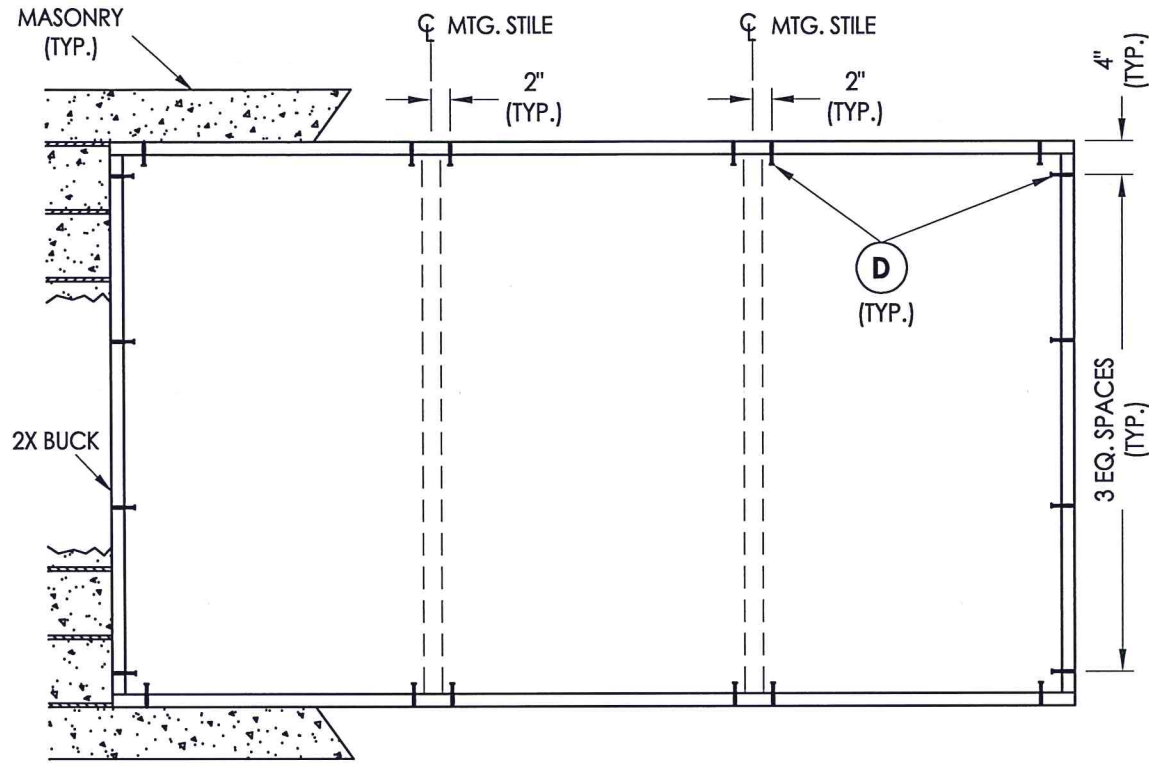

**BUCK ANCHORING**  
1/3 - 1/3 - 1/3

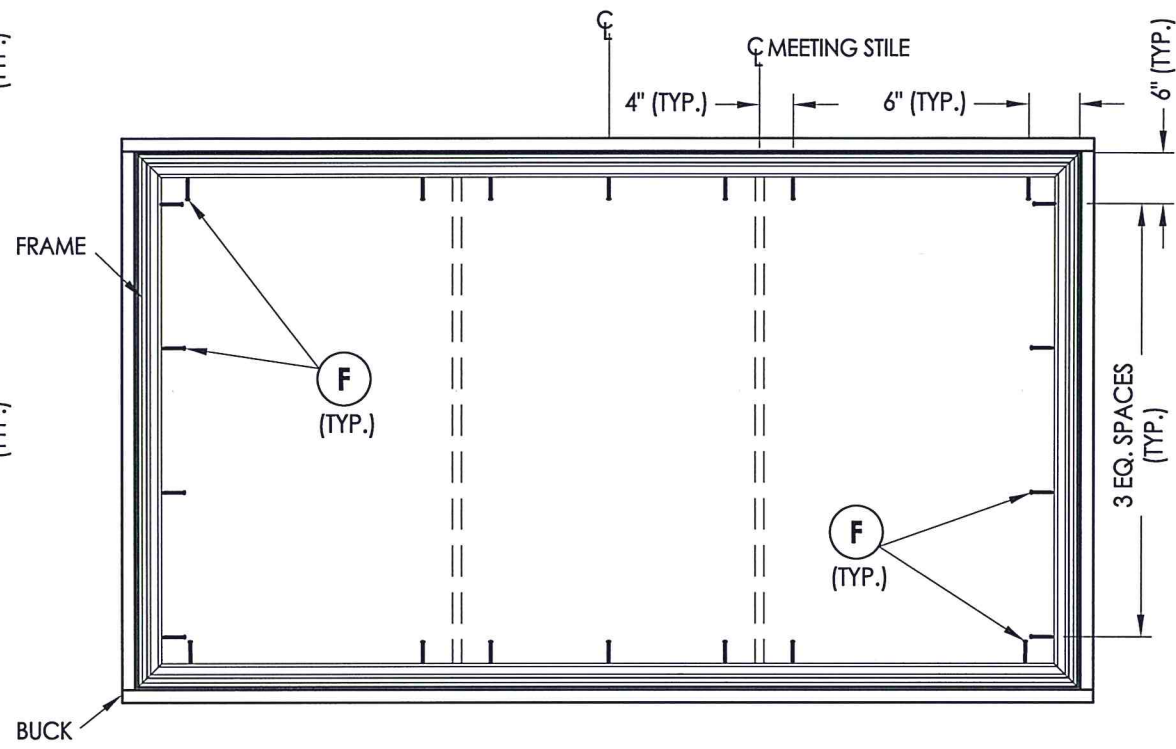

**FRAME ANCHORING**  
1/3 - 1/3 - 1/3

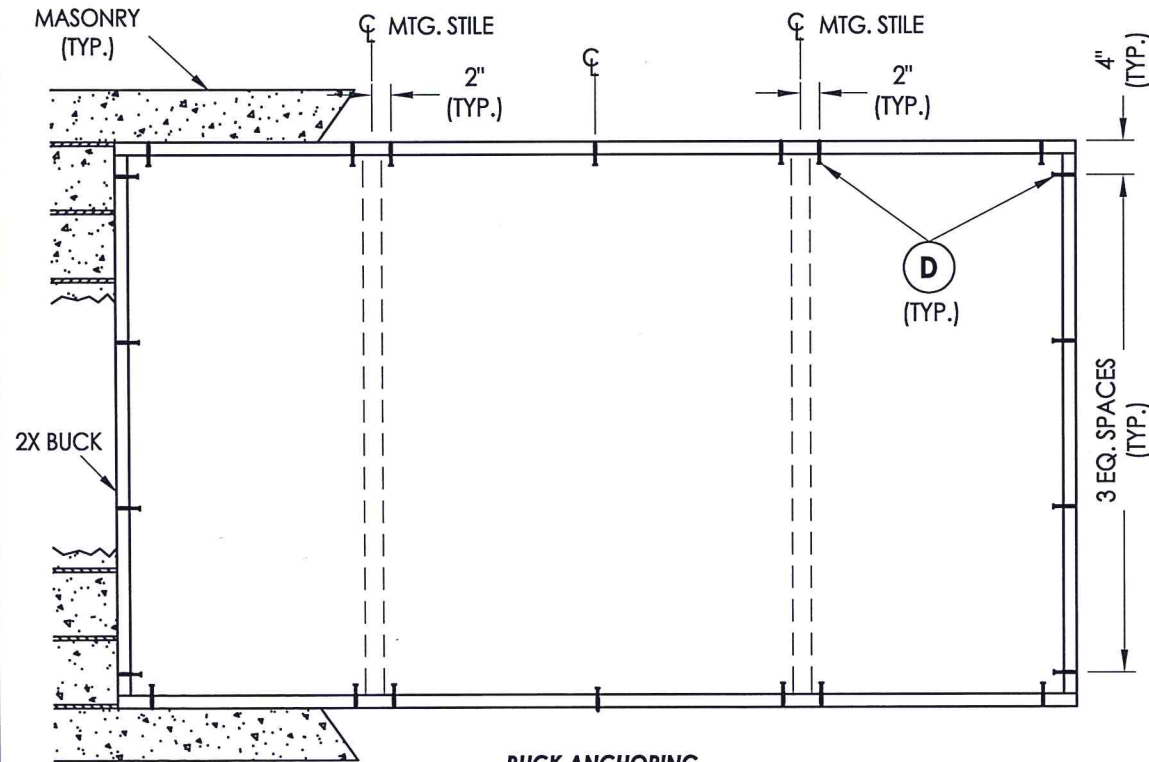

**BUCK ANCHORING**  
1/4 - 1/2 - 1/4

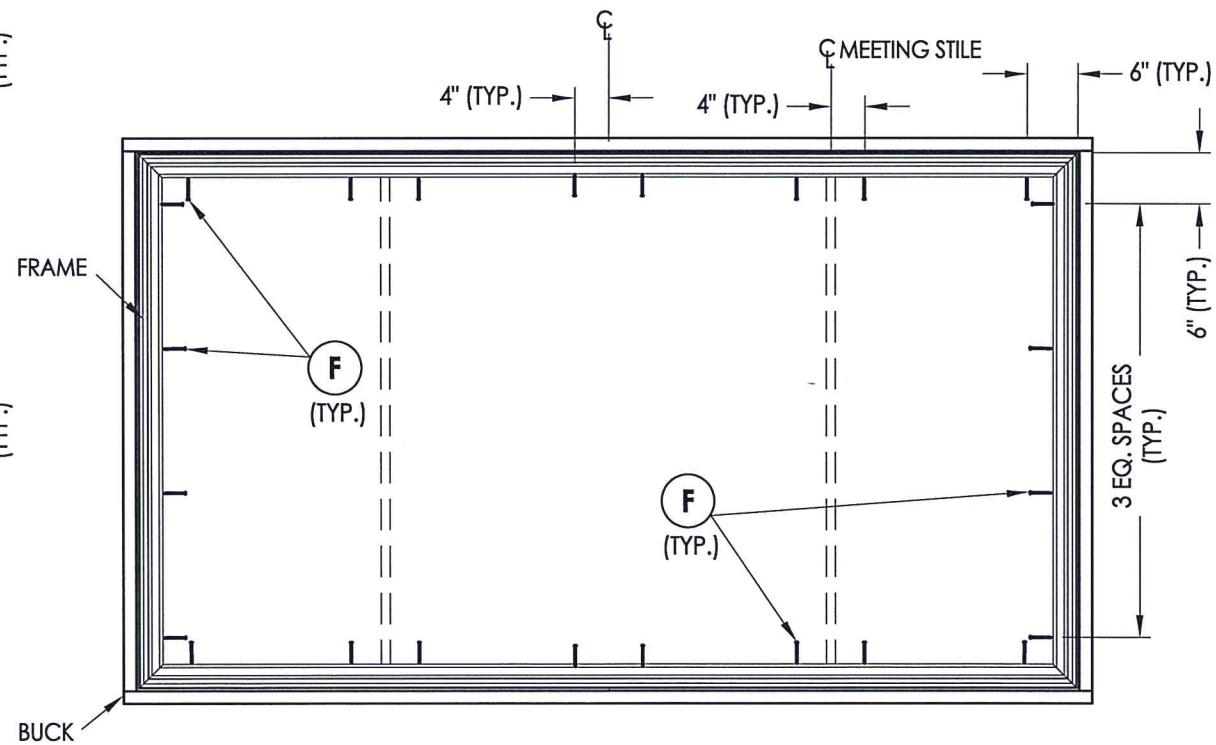

**FRAME ANCHORING**  
1/4 - 1/2 - 1/4



Documents Prepared By: Lyndon F. Schmidt, P.E.  
TEXAS P.E. #104123

**RW** BUILDING CONSULTANTS, INC.  
P.O. Box 230 Valrico FL 33595  
Phone No.: 813.689.9197

TEXAS BOARD OF PROFESSIONAL ENGINEERS  
CERTIFICATE OF REGISTRATION # F-11852

PRODUCT:		SOFT-LITE WINDOWS	
PART OR ASSEMBLY:		BUCK & FRAME ANCHORING	
NO.	DATE	BY	REVISIONS
1	5/11/21	LFS	UPDATE TO 2018 IBC/IRC
DATE: 6/26/18			
SCALE: N.T.S.			
DWG. BY: JK			
CHK. BY: LFS			
DRAWING NO.: TX-4857			
SHEET 4 OF 6			

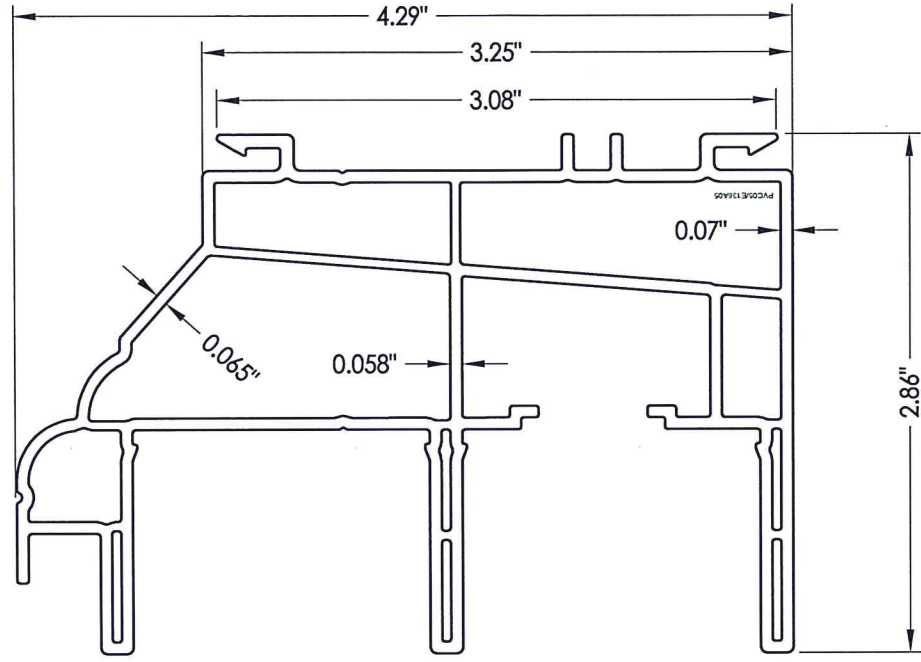

1 FRAME

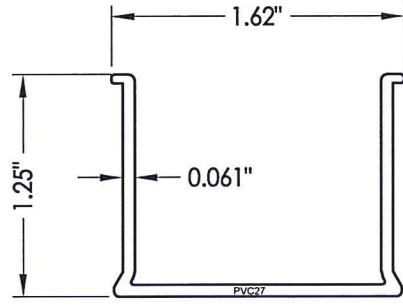

4 FRAME FILLER

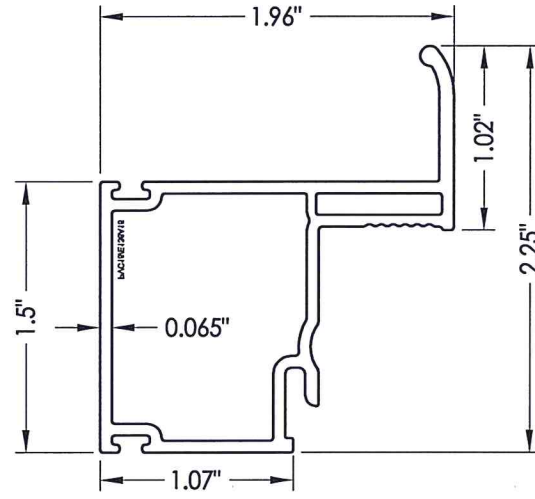

5 HANDLE SASH

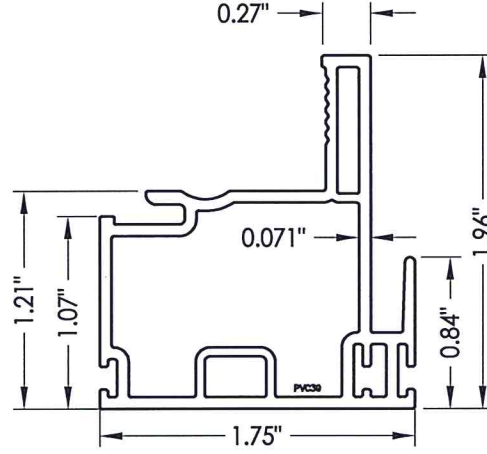

6 KEEPER RAIL

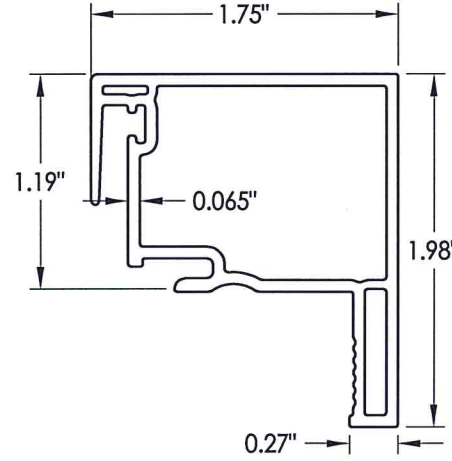

7 LOCK RAIL

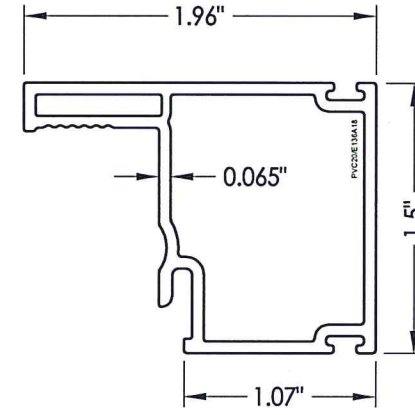

8 MAIN SASH

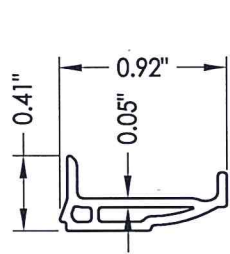

9 GLAZING BEAD

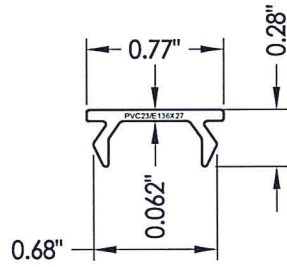

10 COVER

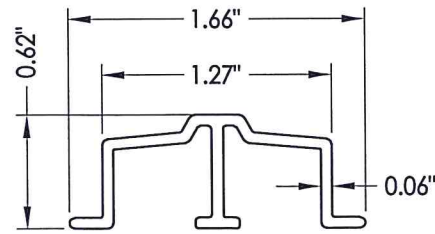

11 ANTI LIFT TRACK

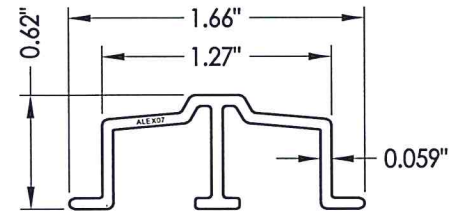

12 SILL ROLLER TRACK

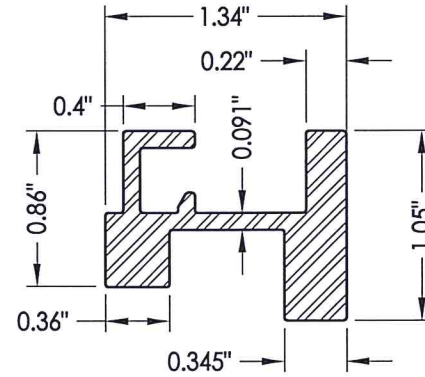

13 REINFORCEMENT

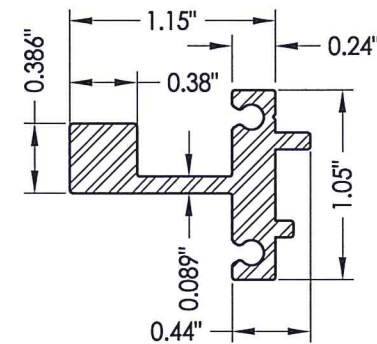

14 REINFORCEMENT

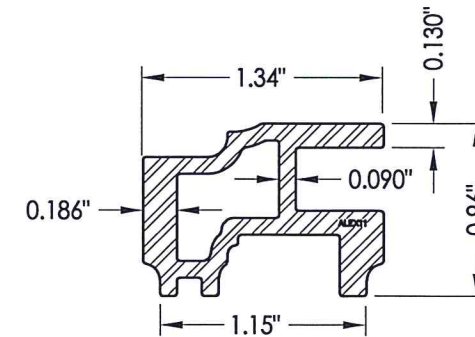

15 REINFORCEMENT

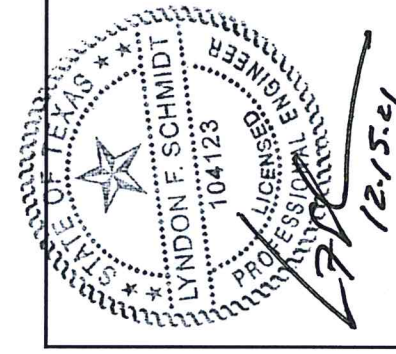

Documents Prepared By: Lyndon F. Schmidt, P.E.  
TEXAS P.E. #104123

RW BUILDING CONSULTANTS, INC.  
P.O. Box 230 Valrico FL 33595  
Phone No.: 813.659.9197

TEXAS BOARD OF PROFESSIONAL ENGINEERS  
CERTIFICATE OF REGISTRATION # F-11852

PRODUCT: SOFT-LITE WINDOWS

PART OR ASSEMBLY: COMPONENTS

REVISIONS	
NO.	DATE
1	5/11/21
LFS	IBC/IRC
BY	

DATE: 6/26/18

SCALE: N.T.S.

DWG. BY: JK

CHK. BY: LFS

DRAWING NO.: TX-4857

SHEET 5 OF 6

BILL OF MATERIALS		
ITEM #		MATERIAL
B	2X FRAMING (SG >= 0.42)	WOOD
C	1/4" MAX. SHIM SPACE	-
D	1/4" X 2-3/4" PFH ITW CONCRETE SCREW	STEEL
E	MASONRY - 3,000 PSI MIN. CONCRETE CONFORMING TO ACI 301 OR HOLLOW BLOCK CONFORMING TO ASTM C90	CONCRETE
F	#8-15 X 2-1/2" TRUSS HEAD SMS (1-3/8" MIN. EMBEDMENT)	STEEL
1	FRAME*	PVC
3	WEEP HOLE COVER*	PVC
4	FRAME FILLER*	PVC
5	HANDLE SASH*	PVC
6	KEEPER RAIL*	PVC
7	LOCK RAIL*	PVC
8	MAIN SASH*	PVC
9	GLAZING BEAD*	PVC
10	COVER*	PVC
11	ANTILIFT TRACK*	PVC
12	ROLLER SILL TRACK	ALUM.
13	REINFORCEMENT (6065-T5 ALUM)	ALUM.
14	REINFORCEMENT (6065-T5 ALUM)	ALUM.
15	REINFORCEMENT (6065-T5 ALUM)	ALUM.
19	ROLLER ASSM.	-
20	LOCK	-
21	LOCK KEEPER	-
22	#7 X 3/4" PFH TEK (LOCK)	SS
26	#8 X 1" PPH TEK (KEEPER)	SS
28	WEATHERSTRIP (187-270 TRI-FIN)	-

\* THE APPROVED WHITE RIGID PVC EXTERIOR EXTRUSIONS FOR WINDOWS ARE TO BE PRODUCED BY EXTRUDERS LICENSEES IN "AAMA CERTIFICATIONS PROGRAMS FOR RIGID PVC EXTRUSIONS".

**CONCRETE ANCHOR NOTES:**

- Concrete anchor locations at the corners may be adjusted to maintain the min. edge distance to mortar joints.
- Concrete anchor locations noted as "MAX. ON CENTER" must be adjusted to maintain the min. edge distance to mortar joints, additional concrete anchors may be required to ensure the "MAX. ON CENTER" dimension are not exceeded.
- Concrete anchor table:

ANCHOR TYPE	ANCHOR SIZE	MIN. EMBEDMENT	MIN. CLEARANCE TO MASONRY EDGE	MIN. CLEARANCE TO ADJACENT ANCHOR
ITW TAPCON®	1/4"	1-1/4"	2"	4"

**WOOD SCREW INSTALLATION NOTES:**

- Maintain a minimum 5/8" edge distance, 1" end distance, & 1" o.c. spacing of wood screws to prevent the splitting of wood.

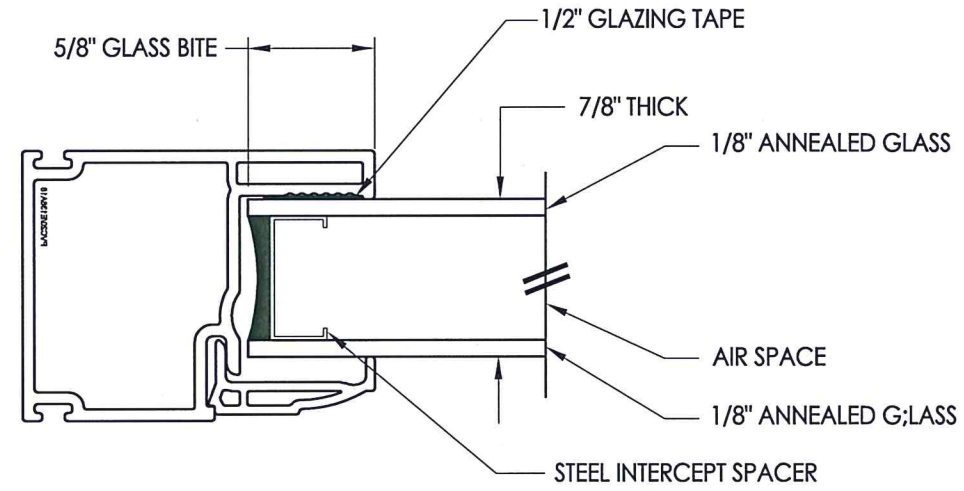

**G1 GLAZING DETAIL**

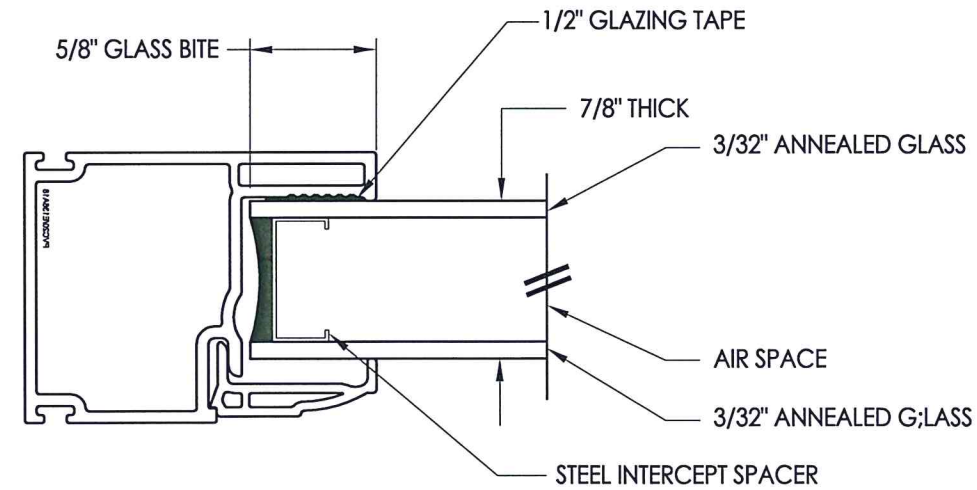

**G2 GLAZING DETAIL**

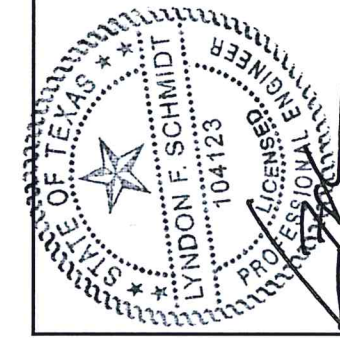

Documents Prepared By: Lyndon F. Schmidt, P.E.  
TEXAS P.E. #104123

**R.W.** BUILDING CONSULTANTS, INC.  
P.O. Box 230 Valrico FL, 33595  
Phone No.: 813.659.9197

TEXAS BOARD OF PROFESSIONAL ENGINEERS  
CERTIFICATE OF REGISTRATION # F-11852

PRODUCT:	SOFT-LITE WINDOWS	
PART OR ASSEMBLY:	BILL OF MATERIALS & GLAZING DETAILS	
NO.	DATE	BY
1	5/11/21	LFS
UPDATE TO 2018 IBC/IRC		
REVISIONS		
DATE:	6/26/18	
SCALE:	N.T.S.	
DWG. BY:	JK	
CHK. BY:	LFS	
DRAWING NO.:	TX-4857	
SHEET	6	OF 6