

ANDERSEN CORPORATION

400 SERIES CASEMENT WINDOW WITH STORMWATCH PROTECTION (IMPACT)



ANDERSEN
WINDOWS & DOORS

100 FOURTH AVE NORTH
BAYPORT, MN 55003-1096
PH: (651) 264-5150 FX: (651) 264-5485

INSTALLATION NOTES:

- ONE (1) INSTALLATION ANCHOR IS REQUIRED AT EACH ANCHOR LOCATION SHOWN, UNLESS OTHERWISE STATED.
- THE NUMBER OF INSTALLATION ANCHORS DEPICTED IS THE MINIMUM NUMBER OF ANCHORS TO BE USED FOR PRODUCT INSTALLATION.
- INSTALL INDIVIDUAL INSTALLATION ANCHORS WITHIN A TOLERANCE OF ±1/2 INCH OF THE DEPICTED LOCATION IN THE ANCHOR LAYOUT DETAIL (I.E., WITHOUT CONSIDERATION OF TOLERANCES). TOLERANCES ARE NOT CUMULATIVE FROM ONE INSTALLATION ANCHOR TO THE NEXT.
- INSTALLATION CLIP: FOR INSTALLATION INTO 2X WOOD FRAME USE TWO (2) #8 WOOD SCREWS OR ONE (1) #12 WOOD SCREW PER INSTALLATION CLIP OF SUFFICIENT LENGTH TO ACHIEVE 1 1/2 INCH MINIMUM EMBEDMENT INTO WOOD SUBSTRATE.
- INSTALLATION CLIP: FOR INSTALLATION THROUGH 1X BUCK TO CONCRETE/MASONRY, OR DIRECTLY INTO CONCRETE/ MASONRY, USE ONE (1) 3/16 INCH ITW TAPCON PER INSTALLATION CLIP OF SUFFICIENT LENGTH TO ACHIEVE 1 1/4 INCH MINIMUM EMBEDMENT.
- INSTALLATION CLIP: FOR INSTALLATION THROUGH METAL STUD USE TWO (2) #8 SELF-TAPPING SCREWS PER INSTALLATION CLIP OF SUFFICIENT LENGTH TO ACHIEVE 3 THREADS MINIMUM PENETRATION BEYOND METAL FRAME SUBSTRATE.
- MINIMUM EMBEDMENT AND EDGE DISTANCE EXCLUDE WALL FINISHES, INCLUDING BUT NOT LIMITED TO STUCCO, FOAM, BRICK VENEER, AND SIDING.
- INSTALLATION ANCHORS AND ASSOCIATED HARDWARE MUST BE MADE OF CORROSION RESISTANT MATERIAL OR HAVE A CORROSION RESISTANT COATING.
- FOR HOLLOW BLOCK AND GROUT FILLED BLOCK, DO NOT INSTALL INSTALLATION ANCHORS INTO MORTAR JOINTS. EDGE DISTANCE IS MEASURED FROM FREE EDGE OF BLOCK OR EDGE OF MORTAR JOINT INTO FACE SHELL OF BLOCK.
- INSTALLATION ANCHORS SHALL BE INSTALLED IN ACCORDANCE WITH ANCHOR MANUFACTURER'S INSTALLATION INSTRUCTIONS, AND ANCHORS SHALL NOT BE USED IN SUBSTRATES WITH STRENGTHS LESS THAN THE MINIMUM STRENGTH SPECIFIED BY THE ANCHOR MANUFACTURER.
- INSTALLATION ANCHOR CAPACITIES FOR PRODUCTS HEREIN ARE BASED ON SUBSTRATE MATERIALS WITH THE FOLLOWING PROPERTIES:
 - WOOD - MINIMUM SPECIFIC GRAVITY OF 0.42.
 - CONCRETE -MINIMUM COMPRESSIVE STRENGTH OF 3000 PSI.
 - MASONRY - STRENGTH CONFORMANCE TO ASTM C-90.
 - STEEL - MINIMUM YIELD STRENGTH OF 33 KSI. MINIMUM WALL THICKNESS OF 33 MILS. (20 GAUGE)
 - ALUMINUM - 1/8" MINIMUM THICKNESS (6063-T5).

GENERAL NOTES:

- THE PRODUCT SHOWN HEREIN IS DESIGNED AND MANUFACTURED TO COMPLY WITH THE 2018 INTERNATIONAL BUILDING CODE (IBC) AND INTERNATIONAL RESIDENTIAL CODE (IRC) AND HAS BEEN EVALUATED ACCORDING TO THE FOLLOWING:
 - AAMA/WDMA/CSA 101/I.S.2/A440-17
 - ASTM E1886-13a
 - ASTM E1996-14a
- ADEQUACY OF THE EXISTING STRUCTURAL CONCRETE/MASONRY, 2X AND METAL STUD FRAMING AS A MAIN WIND FORCE RESISTING SYSTEM CAPABLE OF WITHSTANDING AND TRANSFERRING APPLIED PRODUCT LOADS TO THE FOUNDATION IS THE RESPONSIBILITY OF THE ENGINEER OR ARCHITECT OF RECORD FOR THE PROJECT OF INSTALLATION.
- 1X AND 2X BUCKS (WHEN USED) SHALL BE DESIGNED AND ANCHORED TO PROPERLY TRANSFER ALL LOADS TO THE STRUCTURE. BUCK DESIGN AND INSTALLATION IS THE RESPONSIBILITY OF THE ENGINEER OR ARCHITECT OF RECORD FOR THE PROJECT OF INSTALLATION.
- THE INSTALLATION DETAILS DESCRIBED HEREIN ARE GENERIC AND MAY NOT REFLECT ACTUAL CONDITIONS FOR A SPECIFIC SITE. IF SITE CONDITIONS CAUSE INSTALLATION TO DEVIATE FROM THE REQUIREMENTS DETAILED HEREIN, A LICENSED ENGINEER OR ARCHITECT SHALL PREPARE SITE SPECIFIC DOCUMENTS FOR USE WITH THIS DOCUMENT.
- APPROVED IMPACT PROTECTIVE SYSTEM IS NOT REQUIRED TO PROTECT THIS PRODUCT IN AREAS REQUIRING IMPACT RESISTANCE.
- WINDOW FRAME MATERIAL: *PONDEROSA PINE OR EQUAL*.
- GLASS MEETS THE REQUIREMENTS OF ASTM E1300 GLASS CHARTS. SEE SHEET 5 FOR GLAZING DETAILS.
- DESIGNATIONS "X" AND "O" STAND FOR THE FOLLOWING:
X: OPERABLE PANEL
O: FIXED PANEL
- CUSTOM SIZES AVAILABLE UPON REQUEST.

TABLE OF CONTENTS	
SHEET	SHEET DESCRIPTION
1	GENERAL & INSTALLATION NOTES
2	ELEVATIONS
3	ANCHOR LAYOUTS & ANCHOR SCHEDULE
4	VERTICAL SECTIONS
5	HORIZONTAL SECTIONS & GLAZING DETAIL
6	COMPONENTS & BILL OF MATERIALS

DESIGN PRESSURE RATING TABLE						
UNIT	DESCRIPTION	DIMENSIONS	CONFIG.	GLAZING	DESIGN PRESSURE	MISSILE IMPACT RATING
1	CX16	31-1/2" X 71-7/8"	X OR O	G1	+/- 70 PSF	LARGE & SMALL MISSILE IMPACT
2	CXW145	35-15/16" X 52-7/8"	X OR O	G1		
3	C35	71-7/8" X 59-7/8"	OXO	G1		
4	CW25	56-1/2" X 59-7/8"	XO	G1		
5	CW26	56-1/2" X 71-7/8"	XO	G1		

TITLE: 400 SERIES CASEMENT WINDOW WITH STORMWATCH PROTECTION (IMPACT)

GENERAL AND INSTALLATION NOTES

PREPARED BY:

BUILDING DROPS, INC.
398 E. DANIA BEACH BLVD., STE. 338
DANIA BEACH, FL 33004
PH: (954)399-8478
FAX: (954)744-4738
WEB: www.buildingdrops.com



REMARKS	BY	DATE
REVISIONS PER LATEST CCL	MS	09.26.14
2018 IBC UPDATE	SH	03.02.22

THE INSTALLATION DETAILS DESCRIBED HEREIN ARE GENERIC AND MAY NOT REFLECT ACTUAL CONDITIONS FOR A SPECIFIC SITE. IF SITE CONDITIONS CAUSE INSTALLATION TO DEVIATE FROM THE REQUIREMENTS DETAILED HEREIN, A LICENSED ENGINEER OR ARCHITECT SHALL PREPARE SITE SPECIFIC DOCUMENTS FOR USE WITH THIS DOCUMENT.



HERMES F. NORERO, P.E.
TEXAS P.E. No 118471
BUILDING DROPS, INC
398 E. DANIA BEACH BLVD. # 338
DANIA BEACH, FL 33004
TBPE FIRM No. 13734

DATE: 03.02.22

DWG. BY: SH
CHK. BY: HFN

SCALE: NTS

DWG. #: AWD059

SHEET:

1

OF 6

3/29/2022 2:52 PM
s:\projects\andersen windows\tdi-22-0261 - tdi submittal - win1990 re-evaluation & revision\dwgs\awd059 - revision.dwg



100 FOURTH AVE NORTH
BAYPORT, MN 55003-1096
PH: (651) 264-5150 FX: (651) 264-5485

TITLE: 400 SERIES CASEMENT WINDOW
WITH STORMWATCH PROTECTION
(IMPACT)
ELEVATIONS

PREPARED BY:
BUILDING DROPS, INC.
398 E. DANIA BEACH BLVD., STE. 338
DANIA BEACH, FL 33004
PH: (954) 359-8478
FAX: (954) 744-4738
WEB: www.buildingdrops.com



REMARKS	BY	DATE
REVISIONS PER LATEST CCL	MS	09.26.14
2018 IBC UPDATE	SH	03.02.22

THE INSTALLATION DETAILS DESCRIBED HEREIN ARE GENERIC AND MAY NOT REFLECT ACTUAL CONDITIONS FOR A SPECIFIC SITE. IF SITE CONDITIONS CAUSE INSTALLATION TO DEVIATE FROM THE REQUIREMENTS DETAILED HEREIN, A LICENSED ENGINEER OR ARCHITECT SHALL PREPARE SITE SPECIFIC DOCUMENTS FOR USE WITH THIS DOCUMENT.



HERMES F. NORERO, P.E.
TEXAS P.E. No 118471
BUILDING DROPS, INC
398 E. DANIA BEACH BLVD. # 338
DANIA BEACH, FL 33004
TBPE FIRM No. 13734

DATE:	03.02.22	
DWG. BY:	SH	CHK. BY: HFN
SCALE:	NTS	
DWG. #:	AWD059	

SHEET:
2
OF 6

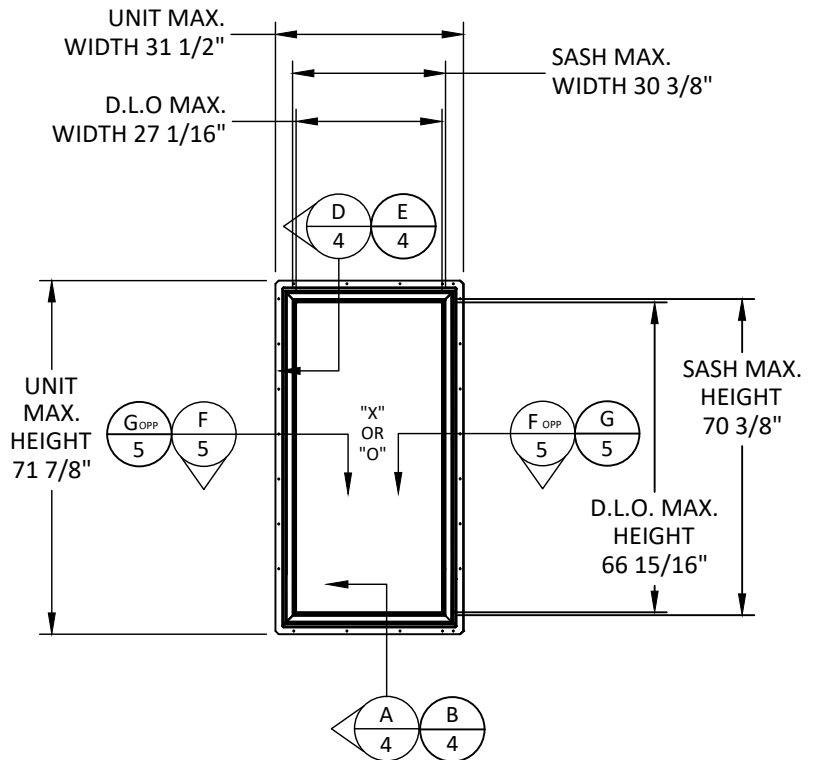

**ELEVATION
CX16**

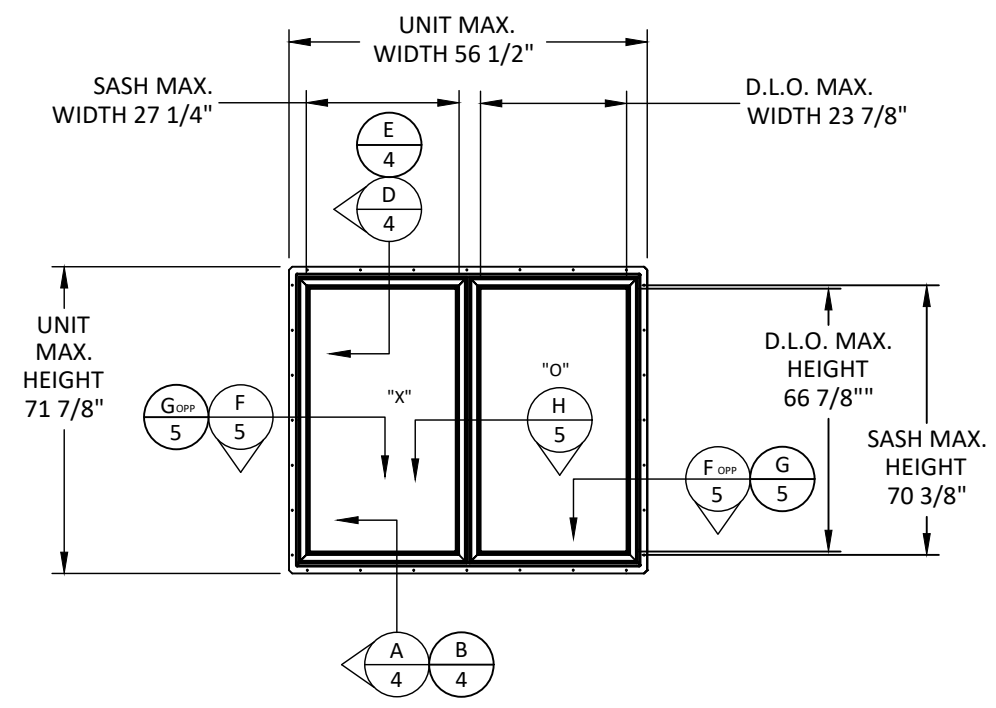

**ELEVATION
CW26**

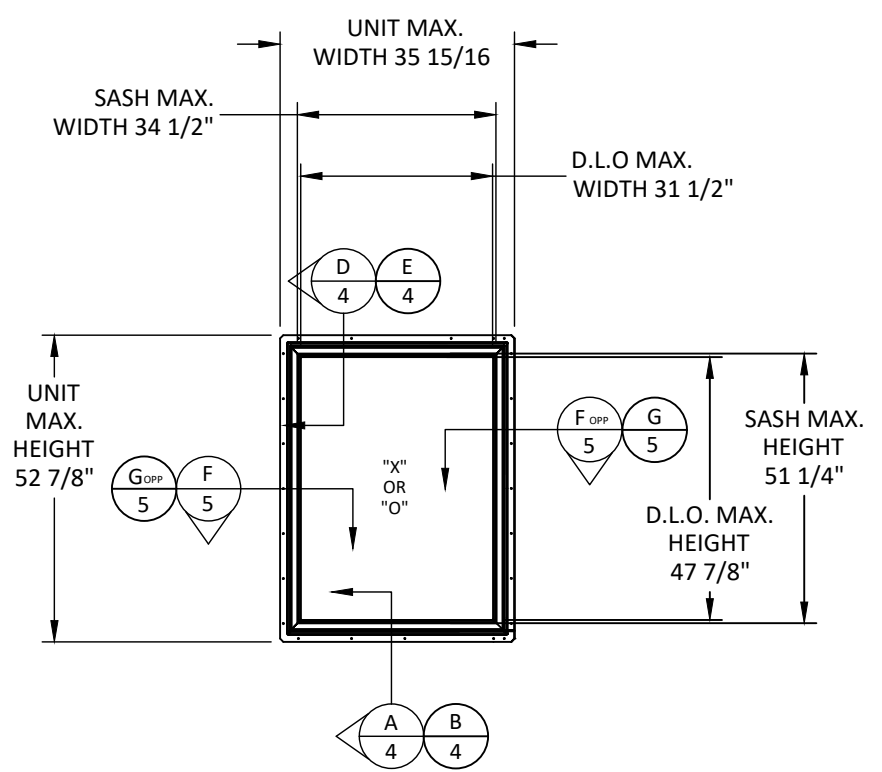

**ELEVATION
CXW145**

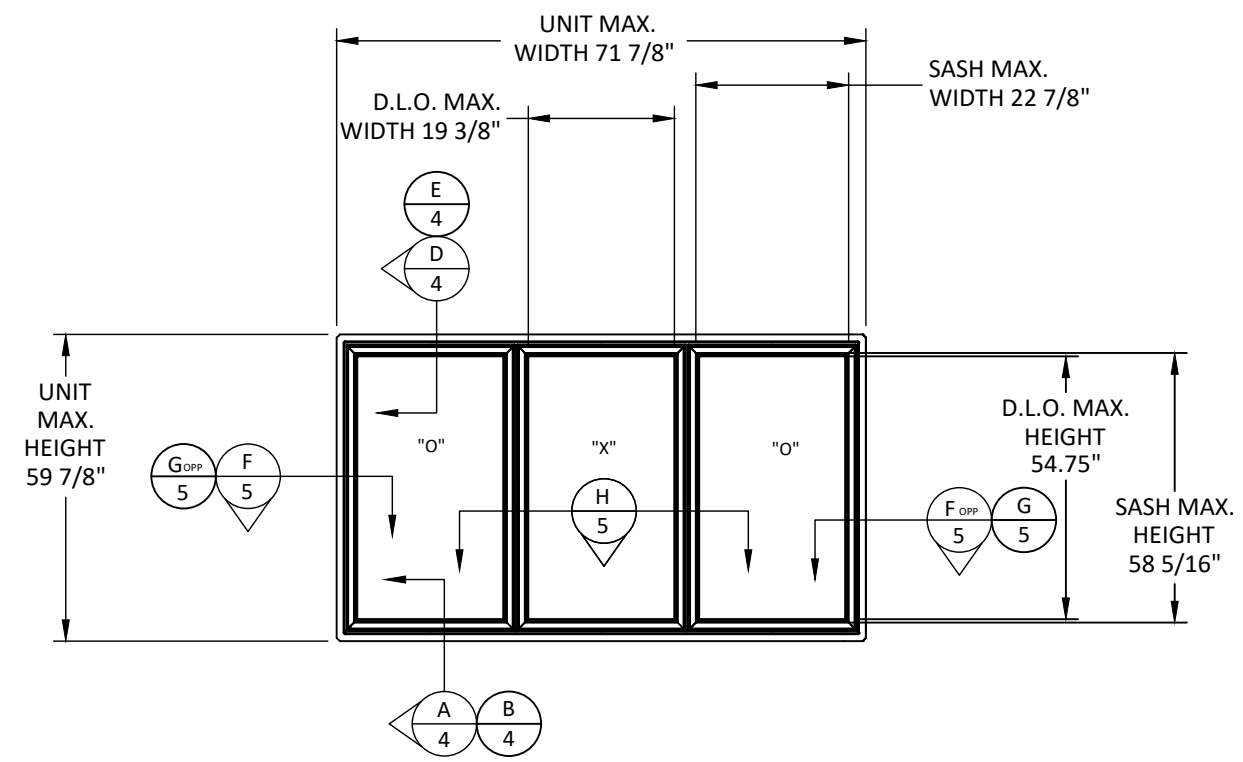

**ELEVATION
C35**

s:\projects\andersen windows\tdi-22-0261 - tdi submittal - win1990 re-evaluation & revision\dwgs\awd059 - revision.dwg 3/29/2022 2:52 PM

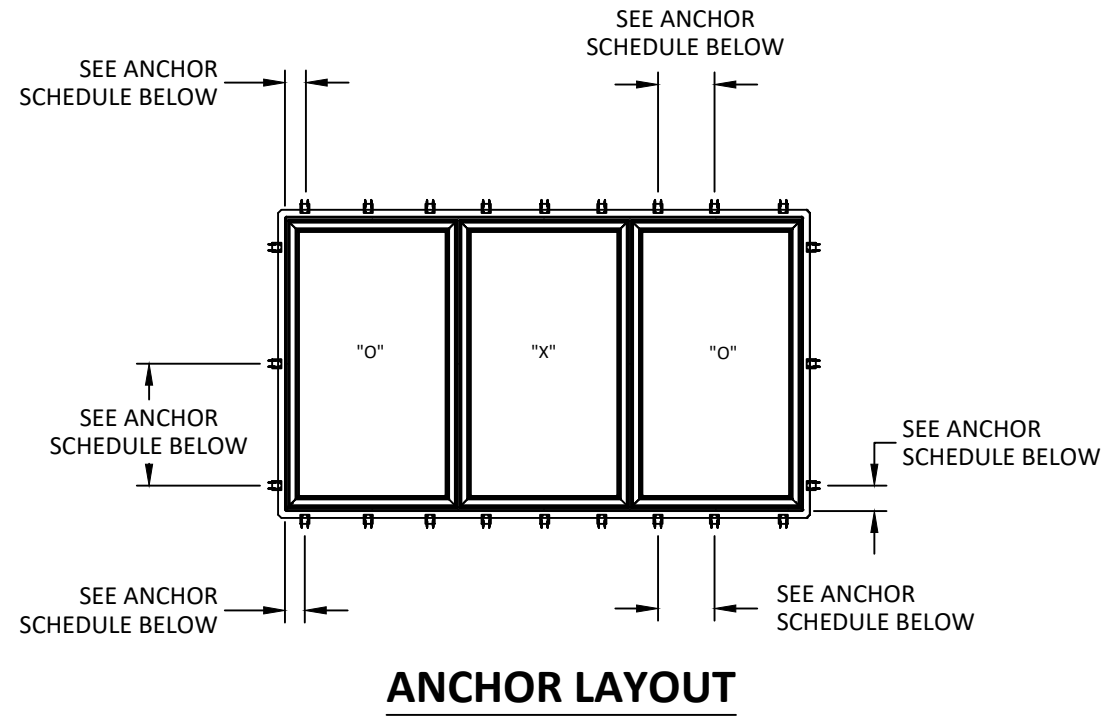
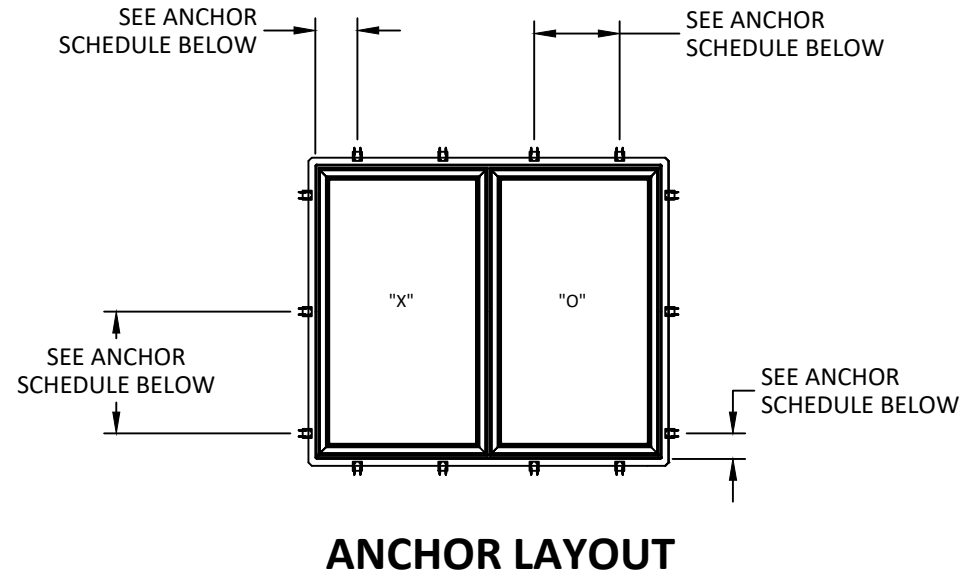
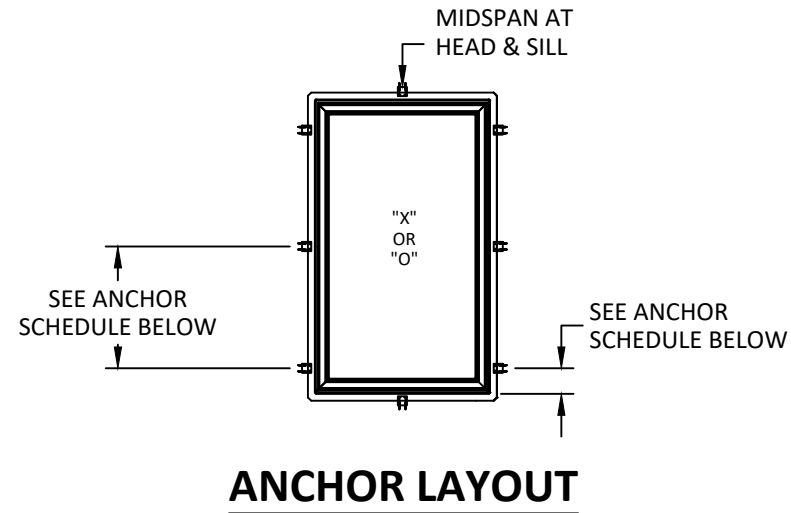

ANCHOR SCHEDULE								
INSTALLATION TYPE	QTY PER LOCATION	SUBSTRATE	ANCHOR TYPE	EMBEDMENT (IN.)	EDGE DISTANCE (IN.)	HEAD/SILL O.C. DISTANCE (IN.)	JAMB O.C. DISTANCE (IN.)	CORNER DISTANCE (IN.)
CLIP	2	WOOD	#8 WOOD ANCHOR	1.5	0.75	15.8	24	12
CLIP	1	WOOD	#12 WOOD ANCHOR	1.5	0.75	15.8	16	12
CLIP	1	CONCRETE/ MASONRY	3/16" ITW TAPCON	1.25	2.5	15.8	24	12
CLIP	2	METAL STUD	#8 SELF-TAPPING SCREW	3 THREADS	N/A	15.8	24	12



100 FOURTH AVE NORTH
BAYPORT, MN 55003-1096
PH: (651) 264-5150 FX: (651) 264-5485

TITLE: 400 SERIES CASEMENT WINDOW WITH STORMWATCH PROTECTION (IMPACT)

ANCHOR LAYOUTS AND ANCHOR SCHEDULE

PREPARED BY: **BUILDING DROPS, INC.**
398 E. DANIA BEACH BLVD., STE. 338
DANIA BEACH, FL 33004
PH: (954) 399-8478
FAX: (954) 744-4738
WEB: www.buildingdrops.com



REMARKS	BY	DATE
REVISIONS PER LATEST CCL	MS	09.26.14
2018 IBC UPDATE	SH	03.02.22

THE INSTALLATION DETAILS DESCRIBED HEREIN ARE GENERIC AND MAY NOT REFLECT ACTUAL CONDITIONS FOR A SPECIFIC SITE. IF SITE CONDITIONS CAUSE INSTALLATION TO DEVIATE FROM THE REQUIREMENTS DETAILED HEREIN, A LICENSED ENGINEER OR ARCHITECT SHALL PREPARE SITE SPECIFIC DOCUMENTS FOR USE WITH THIS DOCUMENT.



HERMES F. NORERO, P.E.
TEXAS P.E. No 118471
BUILDING DROPS, INC
398 E. DANIA BEACH BLVD. # 338
DANIA BEACH, FL 33004
TBPE FIRM No. 13734

DATE: **03.02.22**

DWG. BY: **SH** CHK. BY: **HFN**

SCALE: **NTS**

DWG. #: **AWD059**

SHEET:

3

3/29/2022 2:52 PM
s:\projects\andersen windows\tdi-22-0261 - tdi submittal - win1990 re-evaluation & revision\dwg\awd059 - revision.dwg

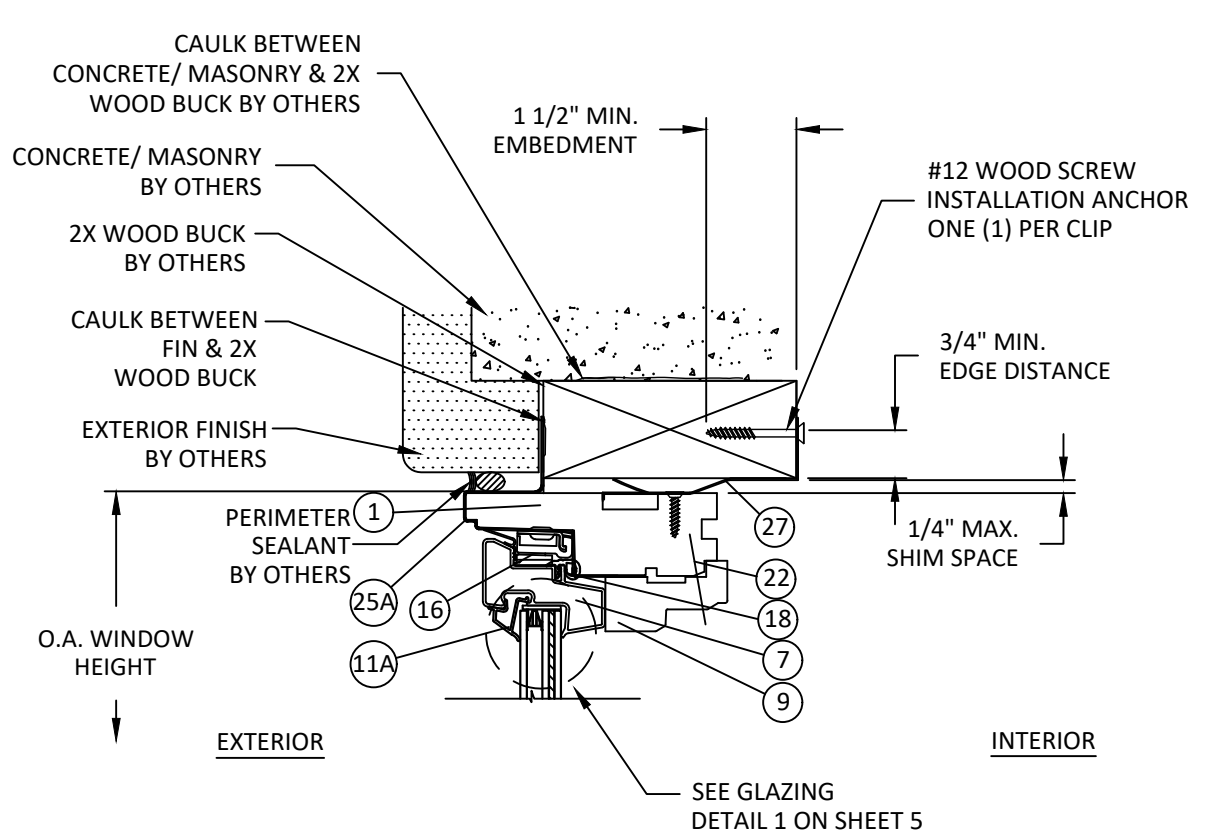

D
4 **VERTICAL SECTION**
HEAD - 2X WOOD FRAME
INSTALLATION CLIP

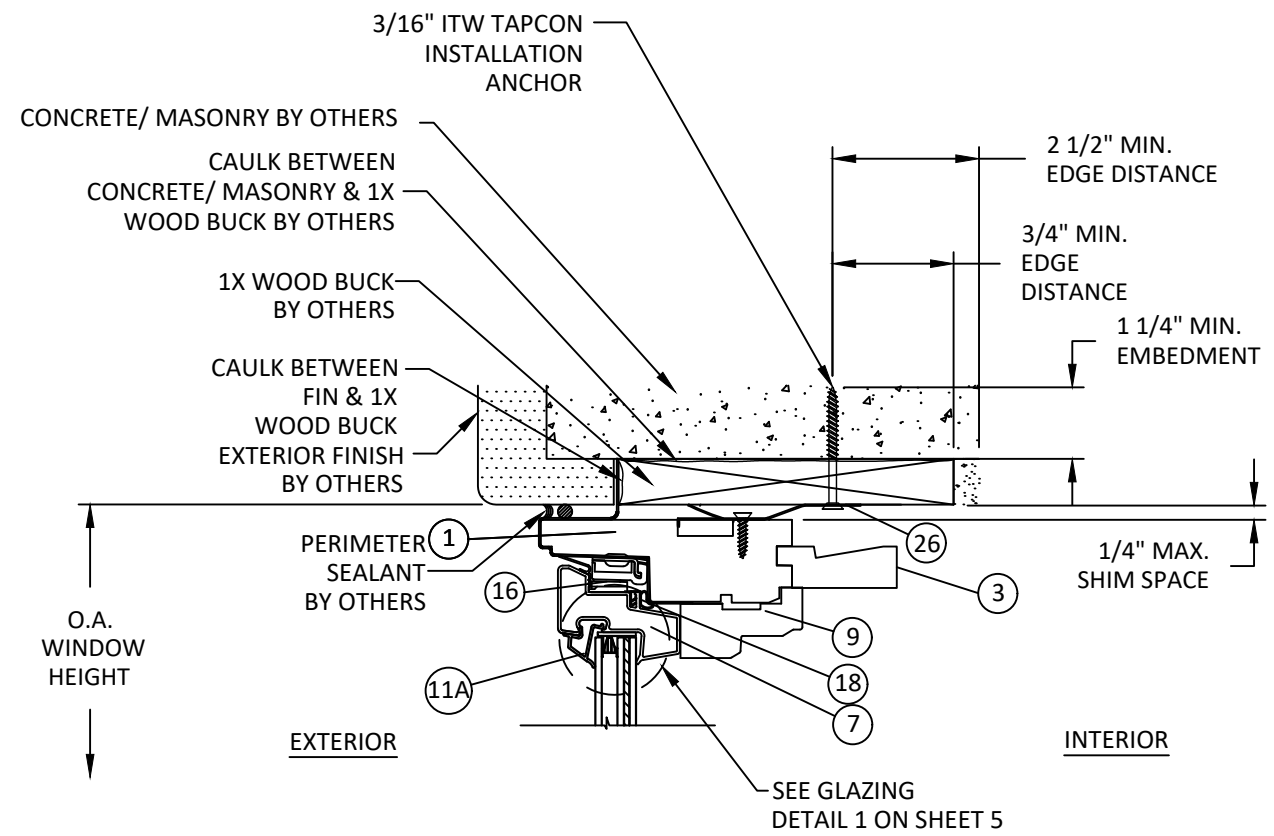

E
4 **VERTICAL SECTION**
HEAD - 1X WOOD/CONCRETE/MASONRY
INSTALLATION CLIP

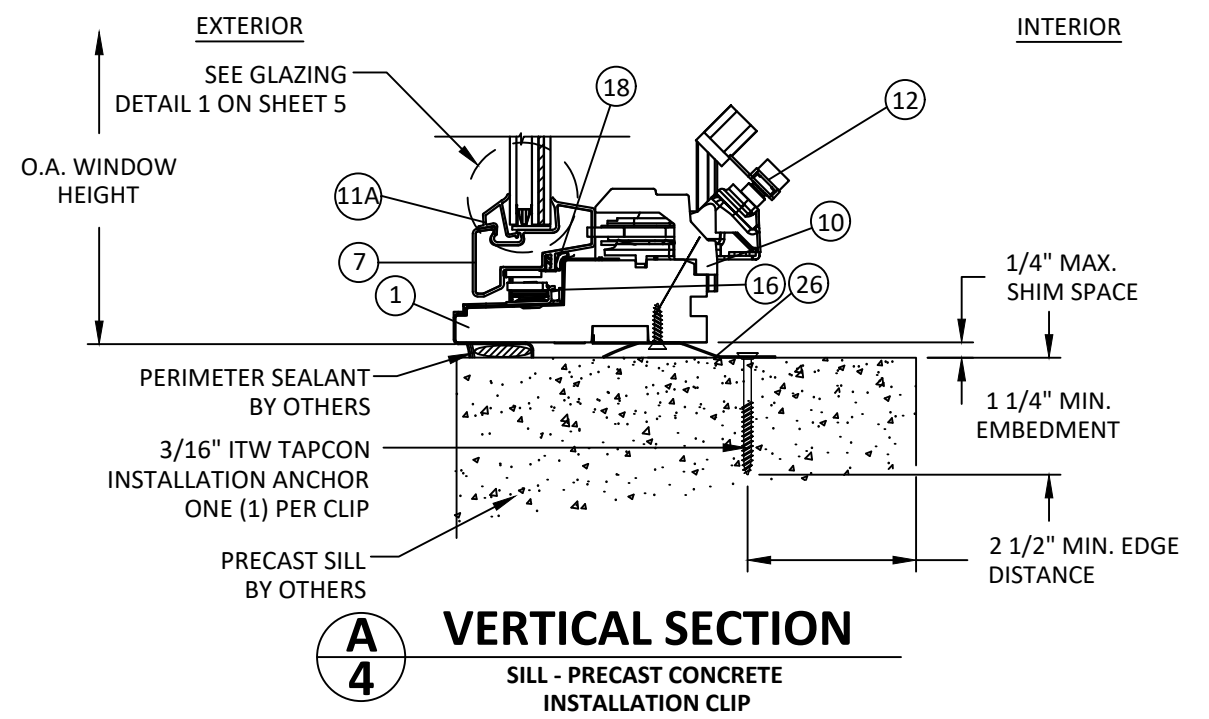

A
4 **VERTICAL SECTION**
SILL - PRECAST CONCRETE
INSTALLATION CLIP

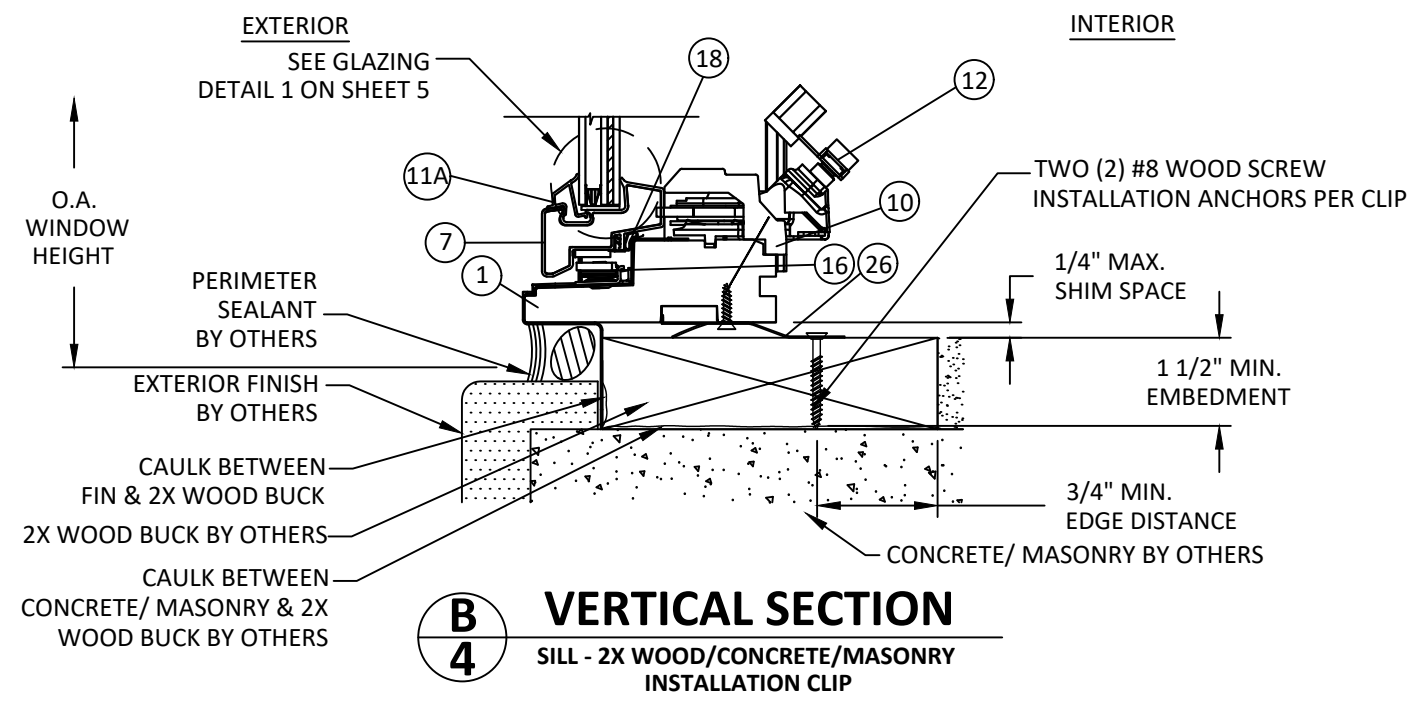

B
4 **VERTICAL SECTION**
SILL - 2X WOOD/CONCRETE/MASONRY
INSTALLATION CLIP

100 FOURTH AVE NORTH
BAYPORT, MN 55003-1096
PH: (651) 264-5150 FX: (651) 264-5485

TITLE: 400 SERIES CASEMENT WINDOW WITH STORMWATCH PROTECTION (IMPACT)
VERTICAL SECTIONS

PREPARED BY: **BD** BUILDING DROPS

BUILDING DROPS, INC.
398 E. DANIA BEACH BLVD., STE. 338
DANIA BEACH, FL 33004
PH: (954) 399-8478
FAX: (954) 744-4738
WEB: www.buildingdrops.com

REMARKS	BY	DATE
REVISIONS PER LATEST CCL	MS	09.26.14
2018 IBC UPDATE	SH	03.02.22

THE INSTALLATION DETAILS DESCRIBED HEREIN ARE GENERIC AND MAY NOT REFLECT ACTUAL CONDITIONS FOR A SPECIFIC SITE. IF SITE CONDITIONS CAUSE INSTALLATION TO DEVIATE FROM THE REQUIREMENTS DETAILED HEREIN, A LICENSED ENGINEER OR ARCHITECT SHALL PREPARE SITE SPECIFIC DOCUMENTS FOR USE WITH THIS DOCUMENT.

HERMES F. NORERO, P.E.
TEXAS P.E. No 118471
BUILDING DROPS, INC
398 E. DANIA BEACH BLVD. # 338
DANIA BEACH, FL 33004
TBPE FIRM No. 13734

DATE: **03.02.22**

DWG. BY: SH	CHK. BY: HFN
SCALE: NTS	
DWG. #: AWD059	

3/29/2022 2:52 PM
s:\projects\andersen windows\tdi-22-0261 - tdi submittal - win1990 re-evaluation & revision\dwg\awd059 - revision.dwg

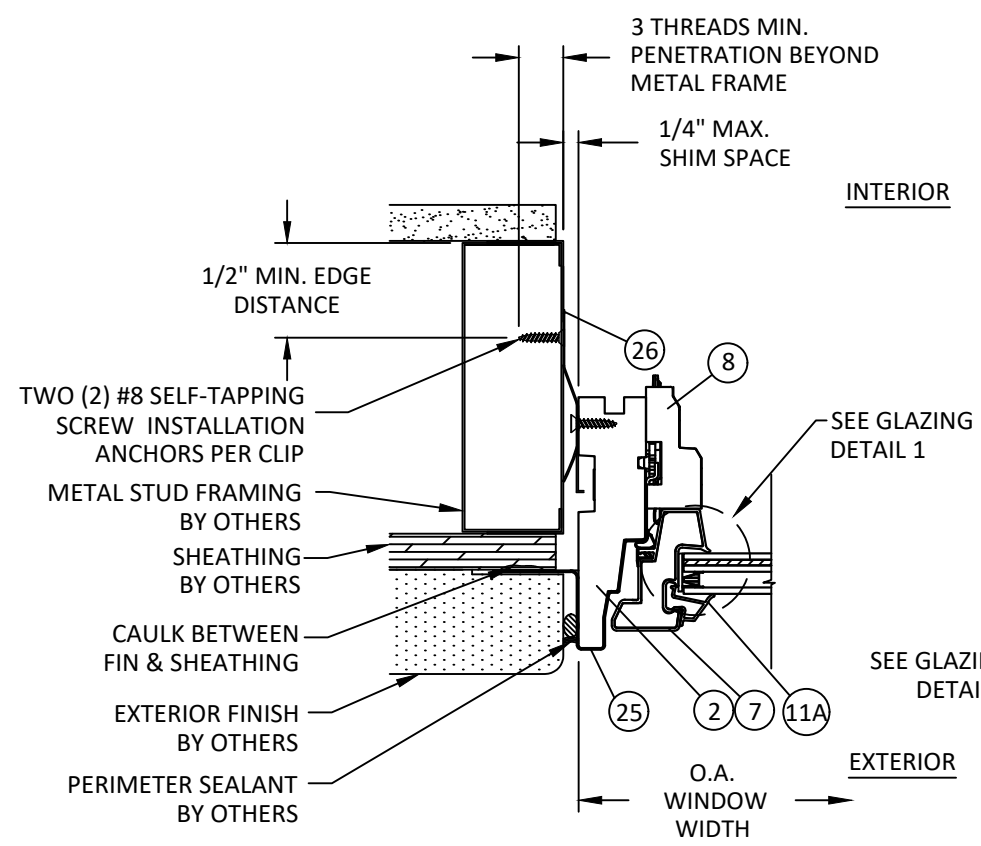

F
5 **HORIZONTAL SECTION**
JAMB - METAL STUD FRAME
INSTALLATION CLIP

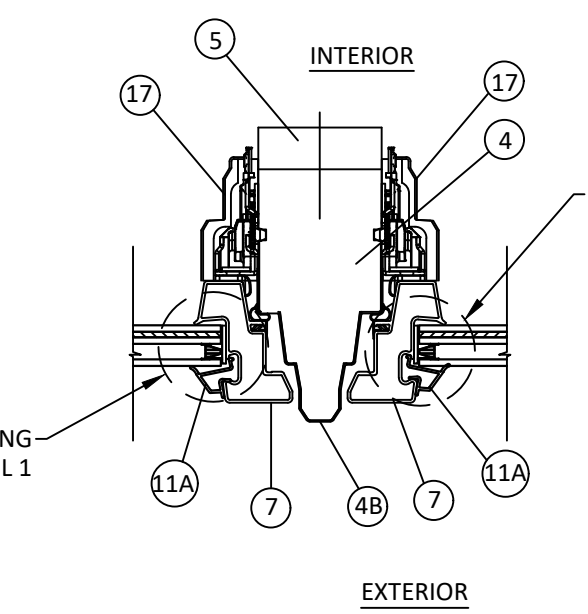

H
5 **HORIZONTAL SECTION**
INTEGRAL MULLION POST

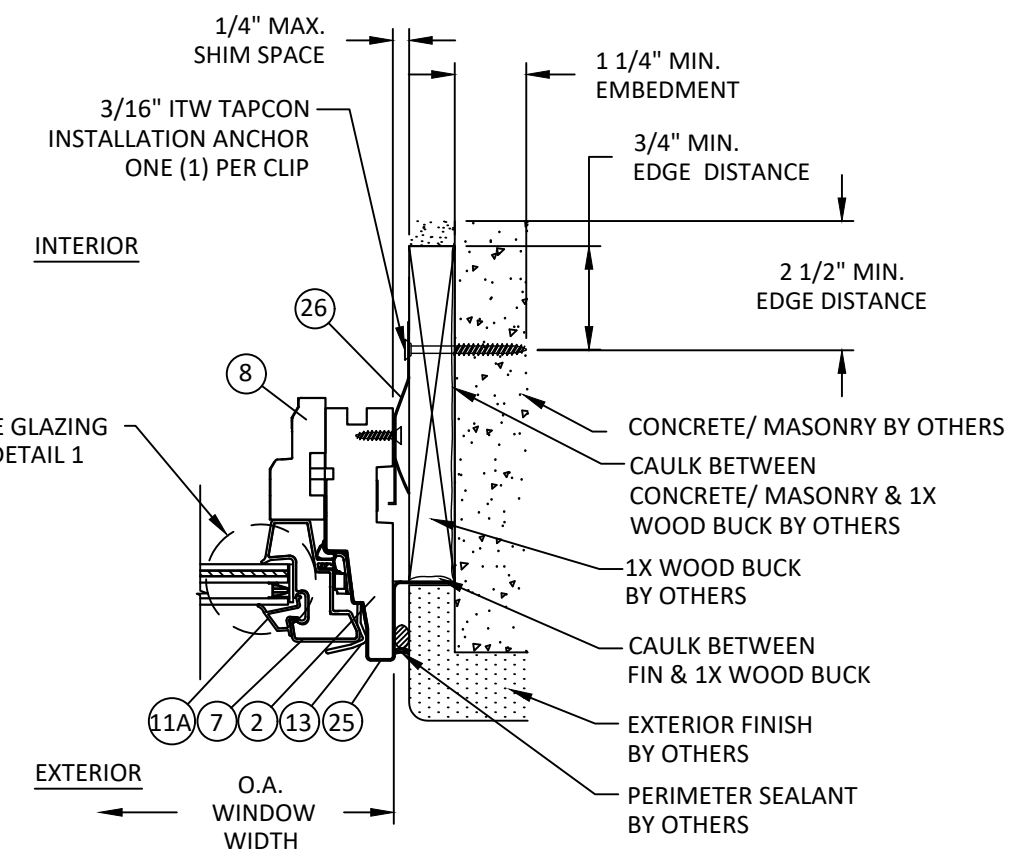

G
5 **HORIZONTAL SECTION**
JAMB - 1X WOOD/CONCRETE/MASONRY
INSTALLATION CLIP

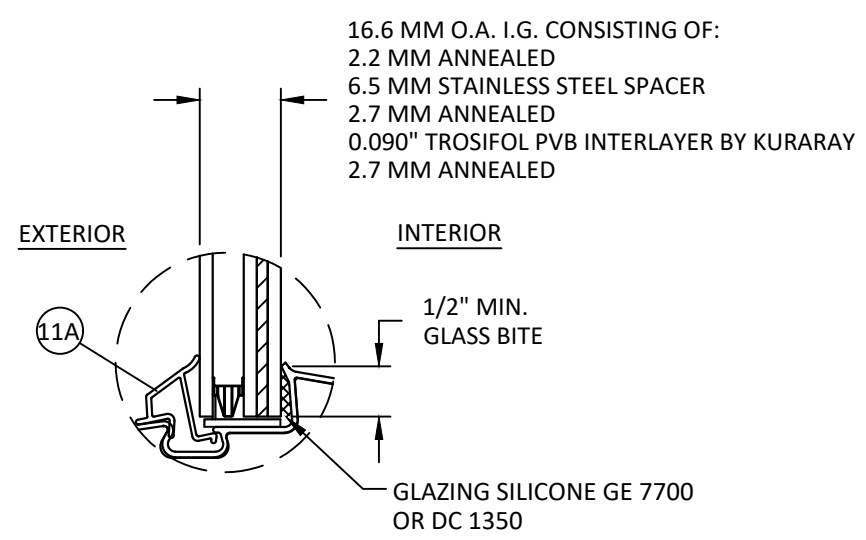

GLAZING DETAIL 1



100 FOURTH AVE NORTH
BAYPORT, MN 55003-1096
PH: (651) 264-5150 FX: (651) 264-5485

TITLE: 400 SERIES CASEMENT WINDOW
WITH STORMWATCH PROTECTION
(IMPACT)
HORIZONTAL SECTIONS
AND GLAZING DETAIL

PREPARED BY:
BUILDING DROPS, INC.
398 E. DANIA BEACH BLVD., STE. 338
DANIA BEACH, FL 33004
PH: (954) 399-8478
FAX: (954) 744-4738
WEB: www.buildingdrops.com

REMARKS	BY	DATE
REVISIONS PER LATEST CCL	MS	09.26.14
2018 IBC UPDATE	SH	03.02.22

THE INSTALLATION DETAILS DESCRIBED HEREIN ARE GENERIC AND MAY NOT REFLECT ACTUAL CONDITIONS FOR A SPECIFIC SITE. IF SITE CONDITIONS CAUSE INSTALLATION TO DEVIATE FROM THE REQUIREMENTS DETAILED HEREIN, A LICENSED ENGINEER OR ARCHITECT SHALL PREPARE SITE SPECIFIC DOCUMENTS FOR USE WITH THIS DOCUMENT.



HERMES F. NORERO, P.E.
TEXAS P.E. No 118471
BUILDING DROPS, INC
398 E. DANIA BEACH BLVD. # 338
DANIA BEACH, FL 33004
TBPE FIRM No. 13734

DATE:	03.02.22	
DWG. BY:	SH	CHK. BY: HFN
SCALE:	NTS	
DWG. #:	AWD059	

SHEET:
5
OF 6

3/29/2022 2:52 PM
s:\projects\andersen windows\tdi-22-0261 - tdi submittal - win1990 re-evaluation & revision\dwg\awd059 - revision.dwg

1 FRAME HEAD/SILL
WOOD

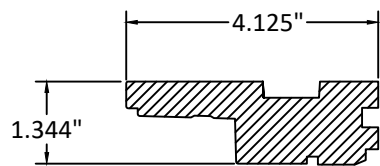

2 FRAME SIDE
WOOD

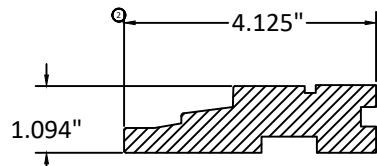

3 EXTENSION JAMB
WOOD

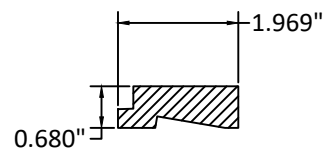

5 MULLION POST CASING
WOOD

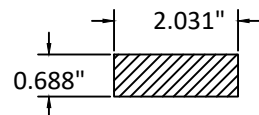

4 MULLION POST
WOOD

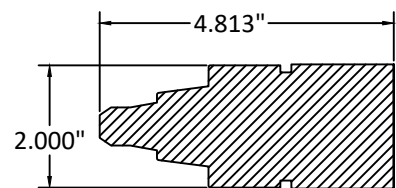

4B MULL POST CLADDING
WOOD

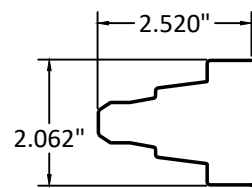

6 SASH RAIL/STILE CLAD.
WOOD

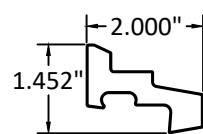

7 SASH RAIL/STILE
WOOD

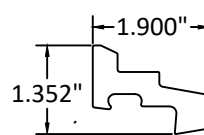

11 GLAZING BEAD - I.G.
PVC

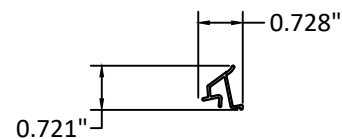

13 SNUGGER
ALUMINUM

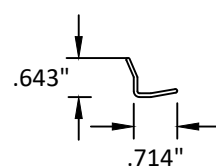

25 FR. SIDE CLADDING
PVC

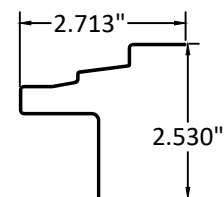

25A FRAME HEAD/SILL CLADDING
PVC

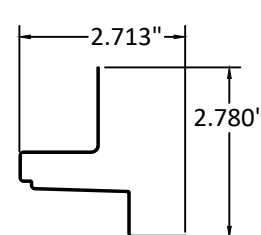

8 TRIM STOP JAMB
WOOD

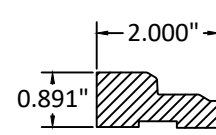

9 TRIM STOP HEAD
WOOD

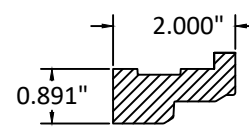

10 TRIM STOP SILL
WOOD

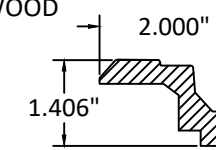

NOTE: ALL WOOD TO BE PONDEROSA PINE OR EQUAL

15 STATIONARY SASH CLIP
GALV. STEEL

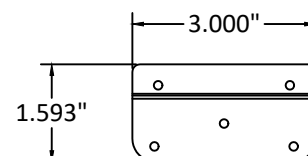

20 SASH REINF. BAR
ALUMINUM

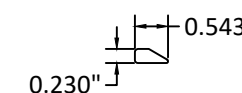

26 INSTALLATION CLIP
304 SS

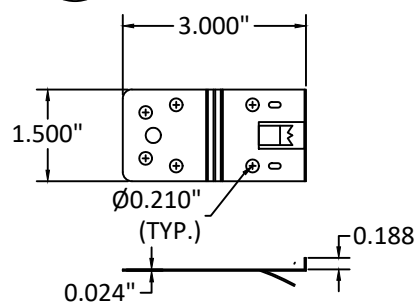

27 INSTALLATION CLIP
304 SS

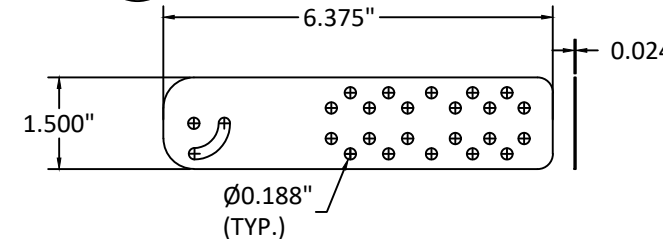

BILL OF MATERIALS

NO	PART NUMBER	DESCRIPTION	MATERIAL	MANUFACTURER
1	30835	FRAME HEAD/SILL	WOOD	ANDERSEN
2	30838	FRAME SIDE	WOOD	ANDERSEN
3		EXTENSION JAMB	WOOD	ANDERSEN
4	30839	MULLION POST	WOOD	ANDERSEN
4B		MULLION POST CLADDING	PVC	ANDERSEN
5	30056	MULLION POST CASING	WOOD	ANDERSEN
6		SASH RAIL/STILE CLADDING	PVC	ANDERSEN
7	30016	SASH RAIL/STILE	WOOD	ANDERSEN
8	30847/8	TRIM STOP JAMB	WOOD	ANDERSEN
9	30840/41	TRIM STOP HEAD	WOOD	ANDERSEN
10	30842-45	TRIM STOP SILL	WOOD	ANDERSEN
11A	30184	GLAZING BEAD - I.G.	PVC	-
11B		-	-	-
12	30809/10	ROTO OPERATOR	STEEL	AMEROCK CORP.
13	30442	SNUGGER	ALUMINUM	-
14	#8 X 1/2"	SNUGGER SCREW	-	-
15	30053	STATIONARY SASH CLIP	GALV. STEEL	-
16		HINGES	STEEL	AMEROCK CORP.
17		LOCK W/ KEEPERS ON SASH	STEEL	AMEROCK CORP.
18	30213/14	WEATHER STRIPPING	-	-
19		NOT USED	-	-
20	30871	SASH REINFORCING BAR	ALUMINUM	-
21	#8 X 5/8"	REINFORCING BARSCREWS	-	-
22		BRAD NAILS 1-1/2" LONG	GALV. STEEL	-
23	30172	FOAM WEATHERSTRIPPING	-	-
24		-	-	-
25	30023	FRAME SIDE CLADDING	PVC	ANDERSEN
25A	30023	FRAME HEAD/SILL CLADDING	PVC	ANDERSEN
26		INSTALLATION CLIP	304 SS	-
27		INSTALLATION CLIP	304 SS	-



100 FOURTH AVE NORTH
BAYPORT, MN 55003-1096
PH: (651) 264-5150 FX: (651) 264-5485

TITLE: 400 SERIES CASEMENT WINDOW
WITH STORMWATCH PROTECTION
(IMPACT)
COMPONENTS AND
BILL OF MATERIALS

PREPARED BY:
BD
BUILDING DROPS
BUILDING DROPS, INC.
398 E. DANIA BEACH BLVD., STE. 338
DANIA BEACH, FL 33004
PH: (954) 399-8478
FAX: (954) 744-4738
WEB: www.buildingdrops.com

REMARKS	BY	DATE
REVISIONS PER LATEST CCL	MS	09.26.14
2018 IBC UPDATE	SH	03.02.22

THE INSTALLATION DETAILS DESCRIBED HEREIN ARE GENERIC AND MAY NOT REFLECT ACTUAL CONDITIONS FOR A SPECIFIC SITE. IF SITE CONDITIONS CAUSE INSTALLATION TO DEVIATE FROM THE REQUIREMENTS DETAILED HEREIN, A LICENSED ENGINEER OR ARCHITECT SHALL PREPARE SITE SPECIFIC DOCUMENTS FOR USE WITH THIS DOCUMENT.



HERMES F. NORERO, P.E.
TEXAS P.E. No 118471
BUILDING DROPS, INC
398 E. DANIA BEACH BLVD. # 338
DANIA BEACH, FL 33004
TBPE FIRM No. 13734

DATE:	03.02.22
DWG. BY:	SH
CHK. BY:	HFN
SCALE:	NTS
DWG. #:	AWD059

SHEET:
6
OF 6