

# MODEL 8300 SYSTEMS 1, 2 AND 3 PICTURE WINDOW - LARGE MISSILE IMPACT

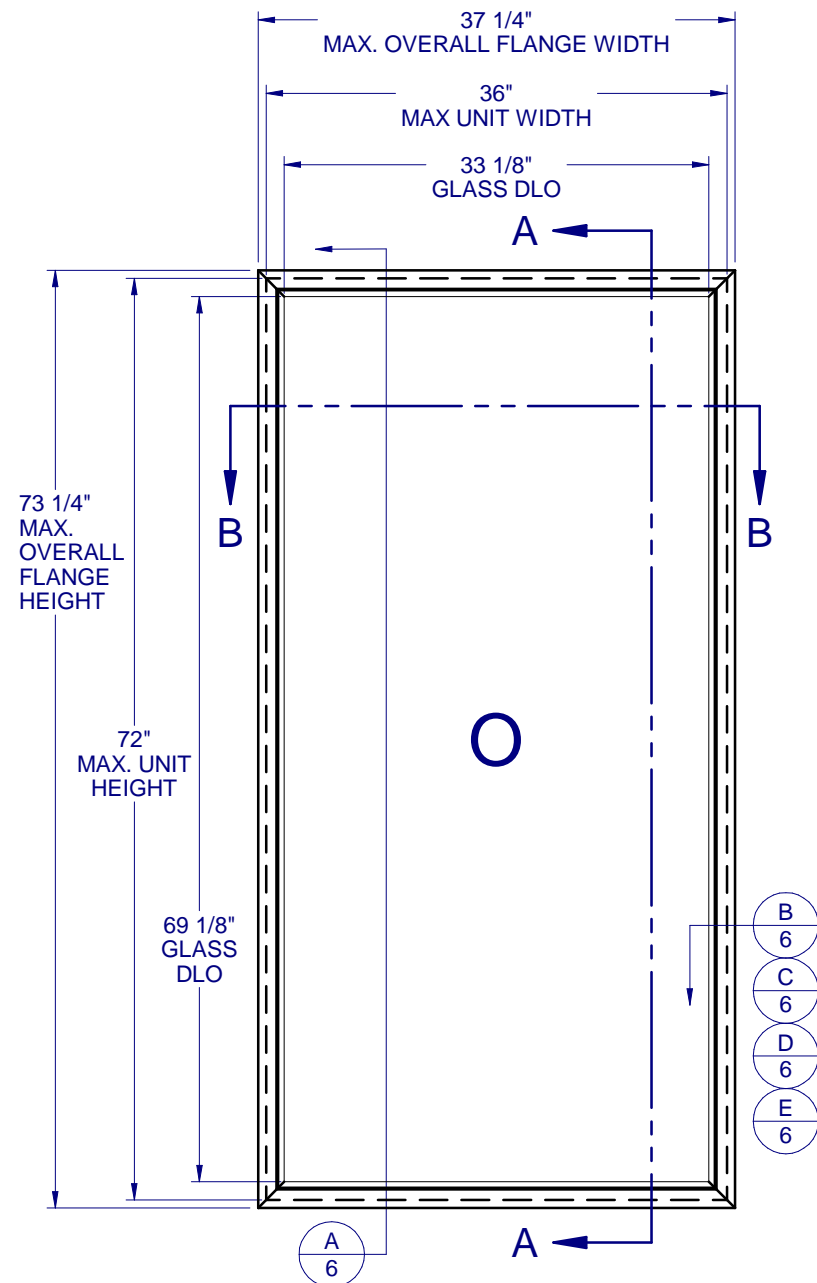

**SYSTEM 1 & 2**  
(CAR 138-535/138-1094/138-540/138-1318)  
MAXIMUM ALLOWABLE DESIGN PRESSURE: +55/-55 PSF

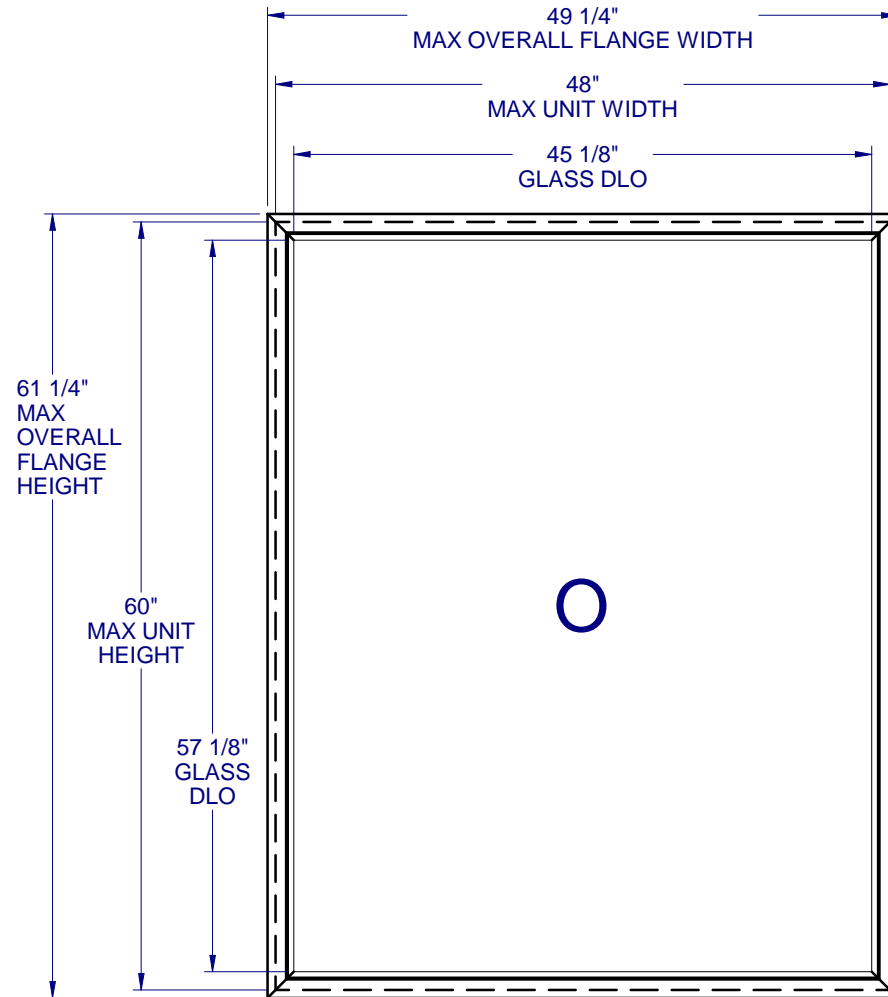

**SYSTEM 3**  
(CAR 138-539/138-1317)  
MAXIMUM ALLOWABLE DESIGN PRESSURE: +50/-50 PSF

**GENERAL NOTES:**

1. THE PRODUCT SHOWN HEREIN IS DESIGNED AND MANUFACTURED TO COMPLY WITH THE REQUIREMENTS OF THE 2018 INTERNATIONAL BUILDING CODE (IBC) AND 2018 INTERNATIONAL RESIDENTIAL CODE (IRC).
2. GLAZING OPTIONS: (SEE SHEET 3)
3. CONFIGURATIONS: "O". ARCHITECTURAL SHAPES INCLUDE, BUT ARE NOT LIMITED TO, THOSE SHOWN ON SHEET 2.
4. ANCHORAGE: THE 33 1/3% STRESS INCREASE HAS NOT BEEN USED IN THE DESIGN OF THIS PRODUCT. SEE SHEET 6 FOR ANCHOR DETAILS. WINDLOAD DURATION FACTOR Cd=1.6 WAS USED FOR WOOD ANCHOR CALCULATIONS.
5. PRODUCT APPROVED FOR IMPACT RESISTANCE. SHUTTERS ARE NOT REQUIRED.
6. ALL FRAMES ARE FULLY WELDED.
7. SERIES / MODEL DESIGNATION PW-8300.
8. THE DESIGNATION X AND O STAND FOR THE FOLLOWING:  
O = FIXED SASH.
9. SECTION CALLOUTS APPLY TO ALL ELEVATIONS IN A SIMILAR LOCATION.

**Custom**  
**WINDOW SYSTEMS**

1900 SW 44TH AVE.  
OCALA, FLORIDA 34474  
WWW.CWS.CC

## 8300 PVC PICTURE WINDOW IMPACT

NO.:	DESCRIPTION:	BY:	DATE:
C	REVISED TO TDI REQUEST	MS	03/23/22
B	IBC/IRC REF. 2018 UPDATE	JLD	05/08/20
A	REVISED TO TDI REQUEST	JML	3/28/17



4/1/2022

LUCAS A. TURNER, P.E.  
TX PE # 115094  
TBPE REG. #F-18075  
2428 OLD NATCHEZ TRC TRL  
CAMDEN, TN 38320  
PH. 941-380-1574

SHEET DESCRIPTION:  
**GENERAL NOTES AND  
ELEVATIONS**

DRAWN BY: <b>EMK</b>	DATE: 11/12/15
DWG #: <b>TDI-1033</b>	REV.: <b>C</b>
SCALE: 1:1	SHEET 1 OF 6

**TABLE OF CONTENTS**

GENERAL NOTES & ELEVATIONS.....1  
 ARCHITECTURAL SHAPES.....2  
 SECTION VIEWS & GLAZING.....3  
 EXTRUSIONS & B.O.M.....4  
 ANCHOR SCHEDULE & NOTES.....5  
 INSTALLATION DETAILS.....6

**8300 PVC  
PICTURE WINDOW  
IMPACT**

				03/23/22	
			MS	JLD	05/08/20
			REVISOR	JML	3/28/17
			NO.:	DESCRIPTION:	DATE:
					BY:
					REVISIONS

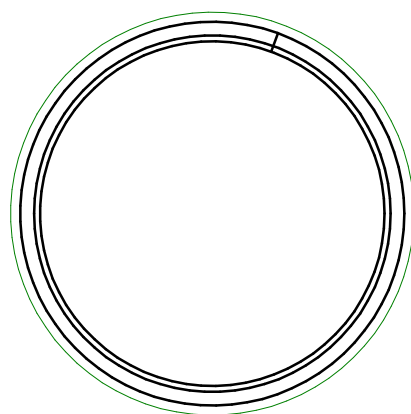

FULL CIRCLE

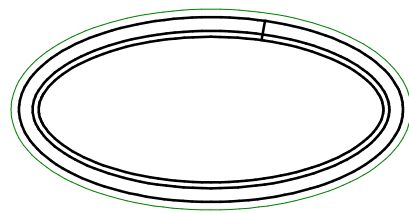

FULL ELLIPSE ("OVAL")

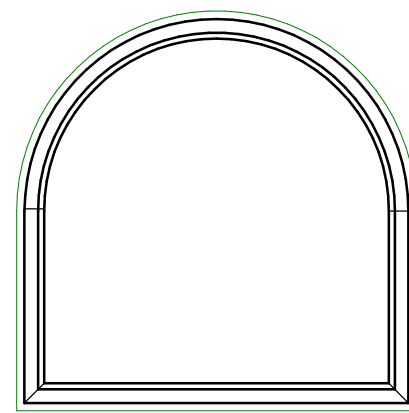

TOMBSTONE

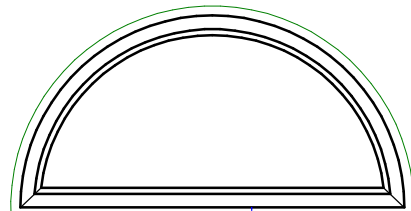

1/2 CIRCLE

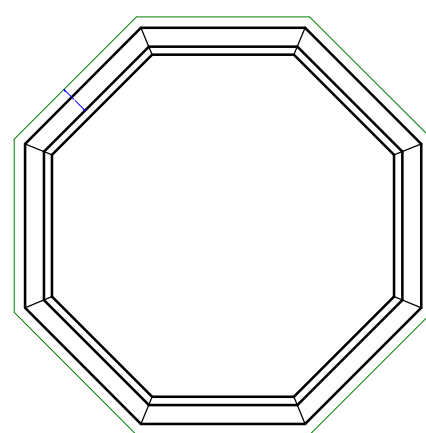

OCTAGON

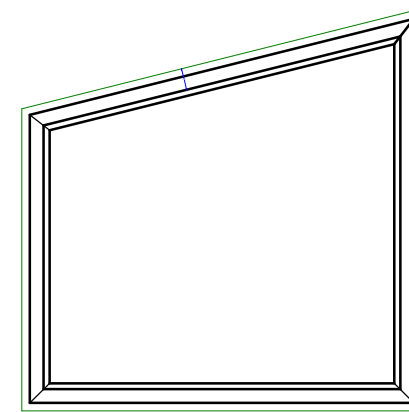

TRAPEZOID

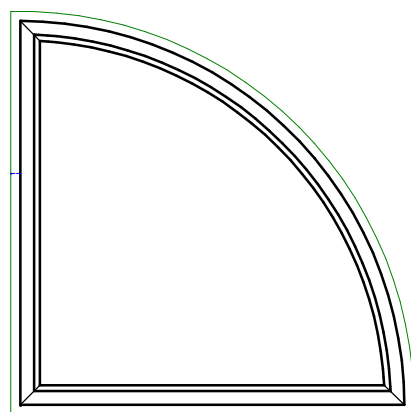

1/4 CIRCLE

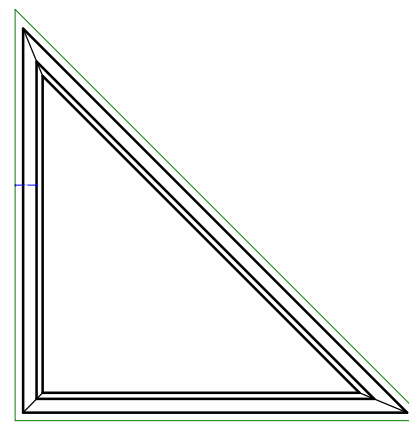

TRIANGLE

NOTES:

1. SEE SHEET 5 FOR DETAILED ANCHOR INSTALLATION REQUIREMENTS.
2. THRU FRAME - MASONRY, WOOD OR METAL OPENING.  
THRU FIN - WOOD OPENING.
3. OVERALL SIZE MUST NOT EXCEED THE MAX. WIDTH AND HEIGHT OF  
RECTANGULAR WINDOWS ON SHEET 1.
4. ANCHOR SPACING FOR ARCHITECTURAL FLANGE AND FIN WINDOWS  
MUST FOLLOW THE LAYOUTS SHOWN ON SHEET 5, WITH ANCHOR  
SPACING MEASURED ALONG THE LENGTH OF THE PRODUCT.



4/1/2022

LUCAS A. TURNER, P.E.  
TX PE # 115094  
TBPE REG. #F-18075  
2428 OLD NATCHEZ TRC TRL  
CAMDEN, TN 38320  
PH. 941-380-1574

SHEET DESCRIPTION:  
**ARCHITECTURAL  
SHAPES**

DRAWN BY:	DATE:
EMK	11/12/15
DWG #:	REV.:
TDI-1033	C
SCALE:	SHEET
1:1	2 OF 6

**8300 PVC  
PICTURE WINDOW  
IMPACT**

NO.:	DESCRIPTION:	BY:	DATE:
C	REVISED TO TDI REQUEST MS	JLD	03/23/22
B	IBC/IRC REF. 2018 UPDATE	JML	05/08/20
A	REVISED TO TDI REQUEST	JML	3/28/17

  
 4/1/2022

LUCAS A. TURNER, P.E.  
TX PE # 115094  
TBPE REG. #F-18075  
2428 OLD NATCHEZ TRC TRL  
CAMDEN, TN 38320  
PH. 941-380-1574

SHEET DESCRIPTION:  
**SECTION VIEWS AND  
GLAZING DETAIL**

DRAWN BY:	DATE:
EMK	11/12/15
DWG #:	REV.:
TDI-1033	C
SCALE:	SHEET
1:2	3 OF 6

INTERIOR

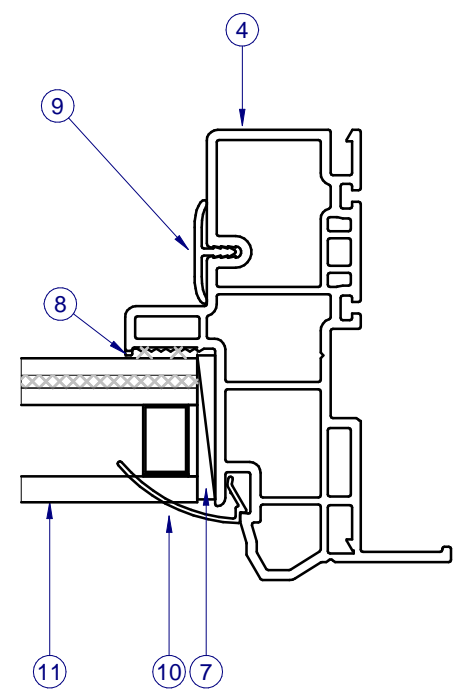
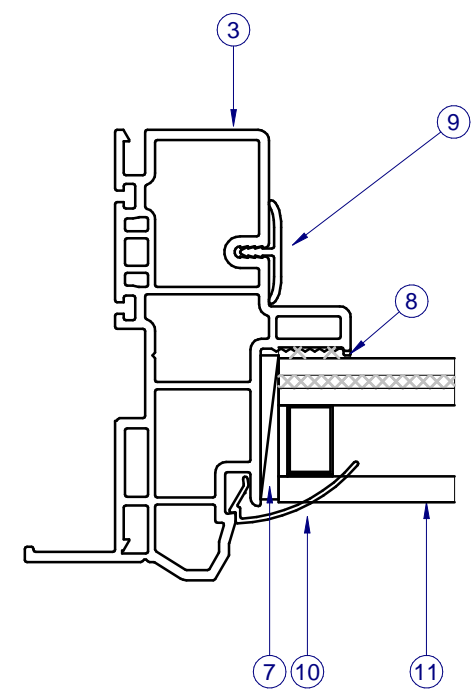

SECTION VIEW B-B

INTERIOR

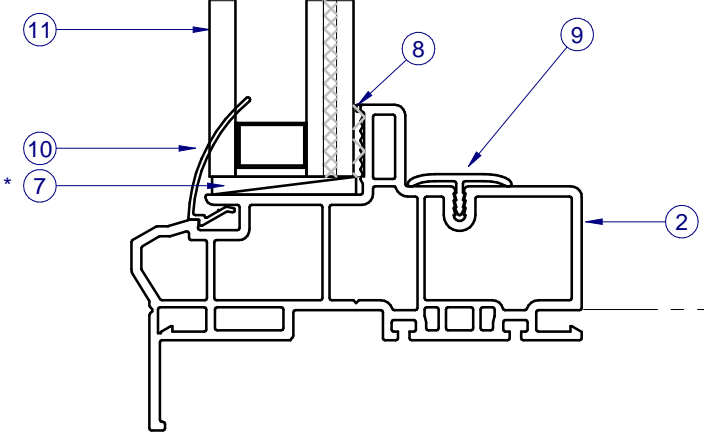
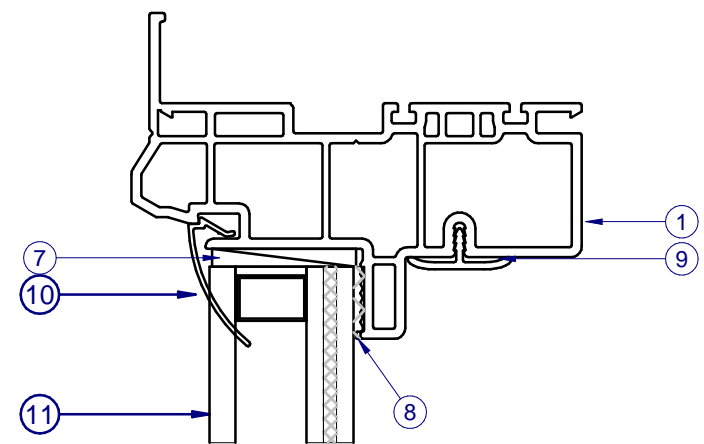

SECTION VIEW A-A

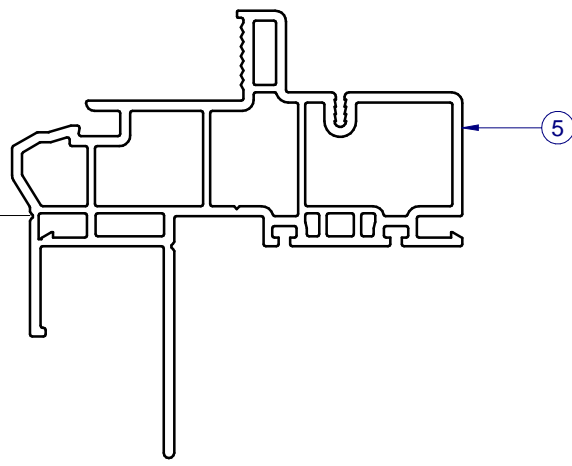

ALTERNATE FIN FRAME

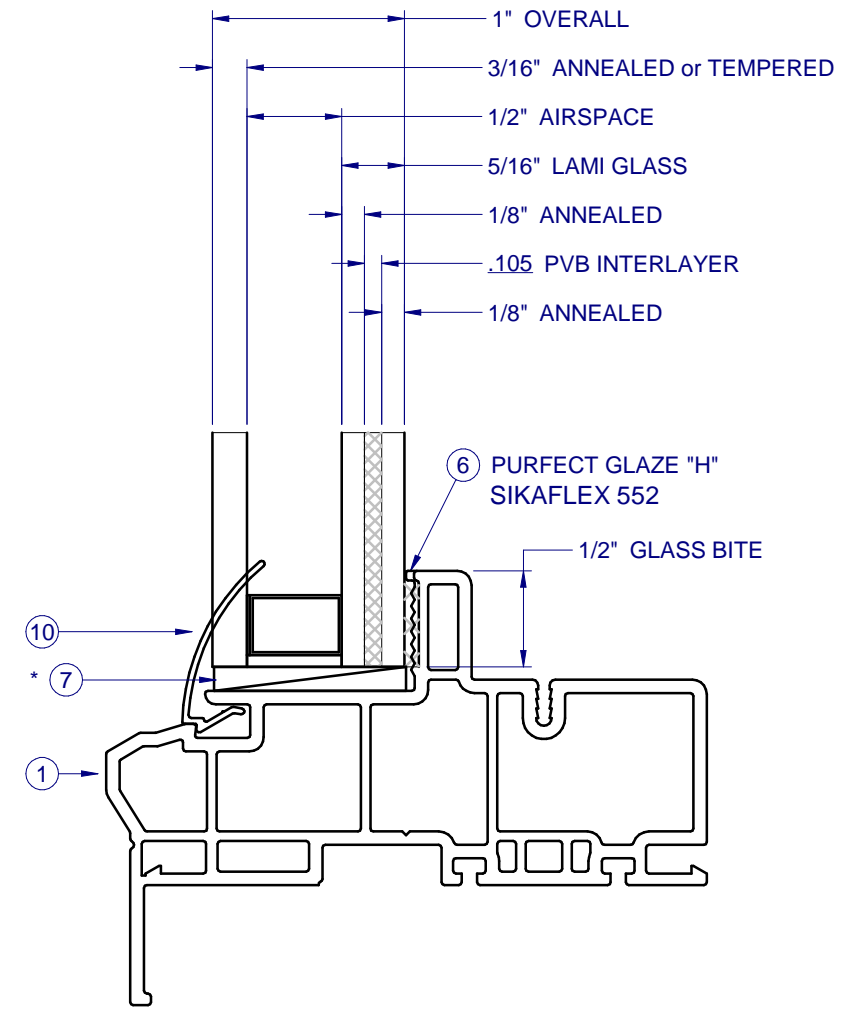

PARTS LIST			
ITEM	PART #	DESCRIPTION	MATERIAL
1	H-6232	FRAME, PW, MAIN, HEAD	PVC
2	H-6232	FRAME, PW, MAIN, SILL	PVC
3	H-6232	FRAME, PW, MAIN, L. JAMB	PVC
4	H-6232	FRAME, PW, MAIN, R. JAMB	PVC
5	H-6232	FRAME, PW, MAIN, FIN	PVC
7	P-5615	SET. BLK., 85 DUR., 1/8" x 1" x 2" LG.	RUBBER
8		PURFECT GLAZE "H", SIKAFLEX 552	SILICONE
9	S-6233	TRIM COVER	PVC
10	S-6237	GLZ. BE., FXD.	PVC
11	GLASS	SEE SHEET 3	

**FRAME CORNER CONSTRUCTION**

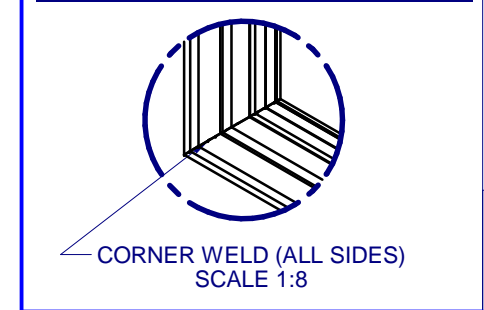

**Custom**  
**WINDOW SYSTEMS**  
1900 SW 44TH AVE.  
OCALA, FLORIDA 34474  
WWW.CWS.CC

**8300 PVC  
PICTURE WINDOW  
IMPACT**

NO.:	DESCRIPTION:	BY:	DATE:
C	REVISED TO TDI REQUEST	MS	03/23/22
B	IBC/IRC REF. 2018 UPDATE	JLD	05/08/20
A	REVISED TO TDI REQUEST	JML	3/28/17

REVISIONS



4/1/2022

LUCAS A. TURNER, P.E.  
TX PE # 115094  
TBPE REG. #F-18075  
2428 OLD NATCHEZ TRC TRL  
CAMDEN, TN 38320  
PH. 941-380-1574

SHEET DESCRIPTION:

**BOM AND EXTRUSIONS**

DRAWN BY:	DATE:
EMK	11/12/15
DWG #:	REV.:
TDI-1033	C
SCALE:	SHEET
1:1	4 OF 6

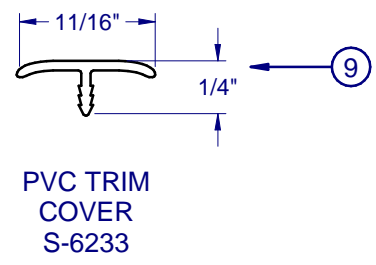
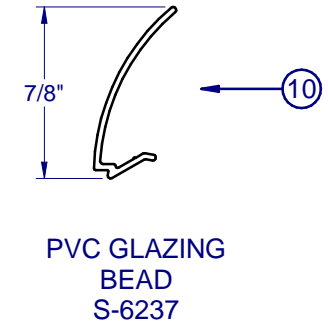
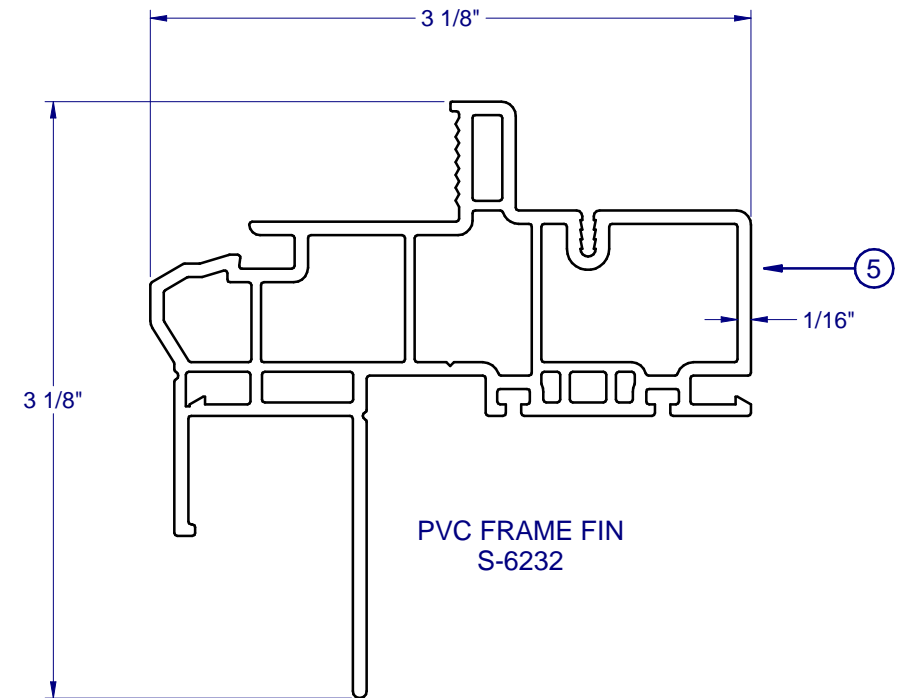
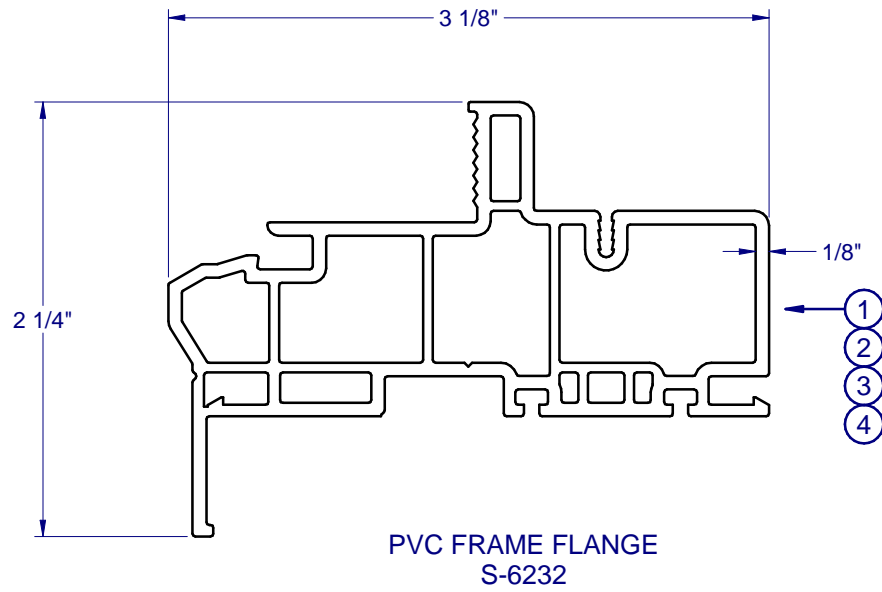

**8300 PVC  
PICTURE WINDOW  
IMPACT**

NO.:	DESCRIPTION:	BY:	DATE:
C	REVISED TO TDI REQUEST	MS	03/23/22
B	IBC/IRC REF. 2018 UPDATE	JLD	05/08/20
A	REVISED TO TDI REQUEST	JML	3/28/17

REVISIONS



4/1/2022

LUCAS A. TURNER, P.E.  
TX PE # 115094  
TBPE REG. #F-18075  
2428 OLD NATCHEZ TRC TRL  
CAMDEN, TN 38320  
PH. 941-380-1574

SHEET DESCRIPTION:

**ANCHOR SCHEDULE AND  
NOTES**

DRAWN BY:	DATE:
EMK	11/12/15
DWG #:	REV.:
TDI-1033	C
SCALE:	SHEET
1:1	5 OF 6

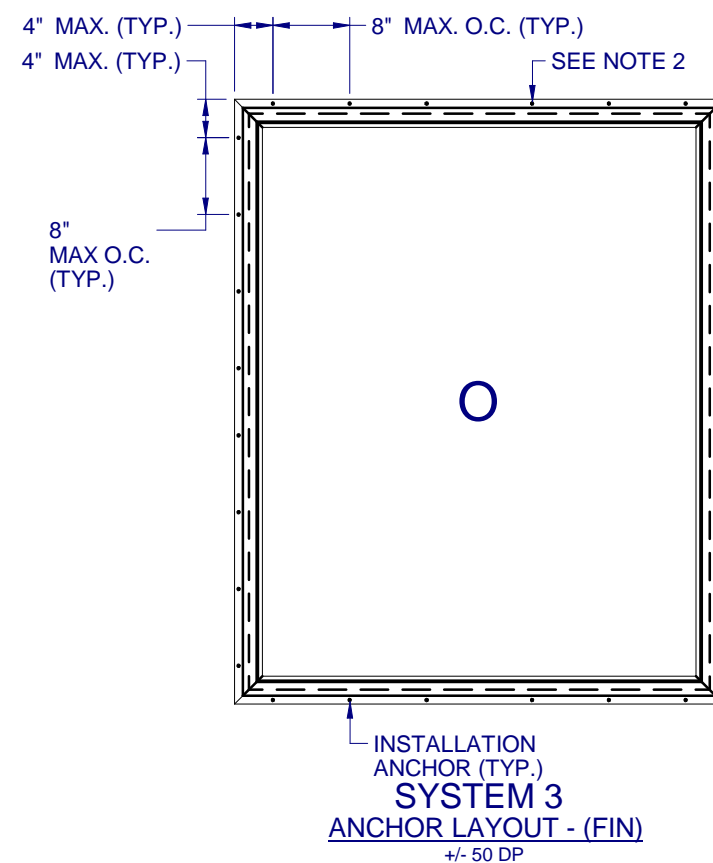
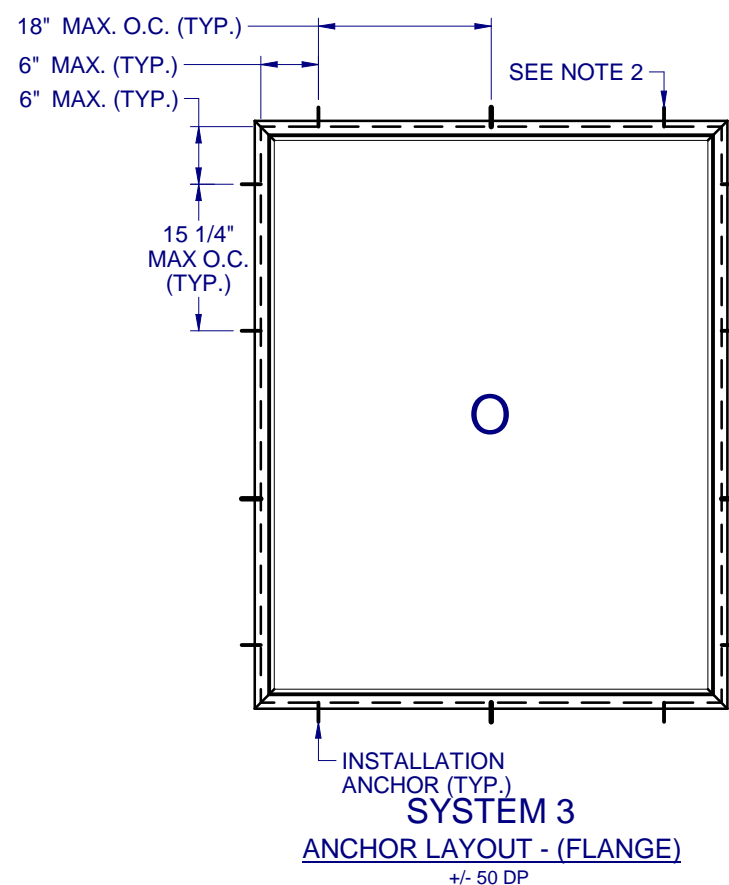
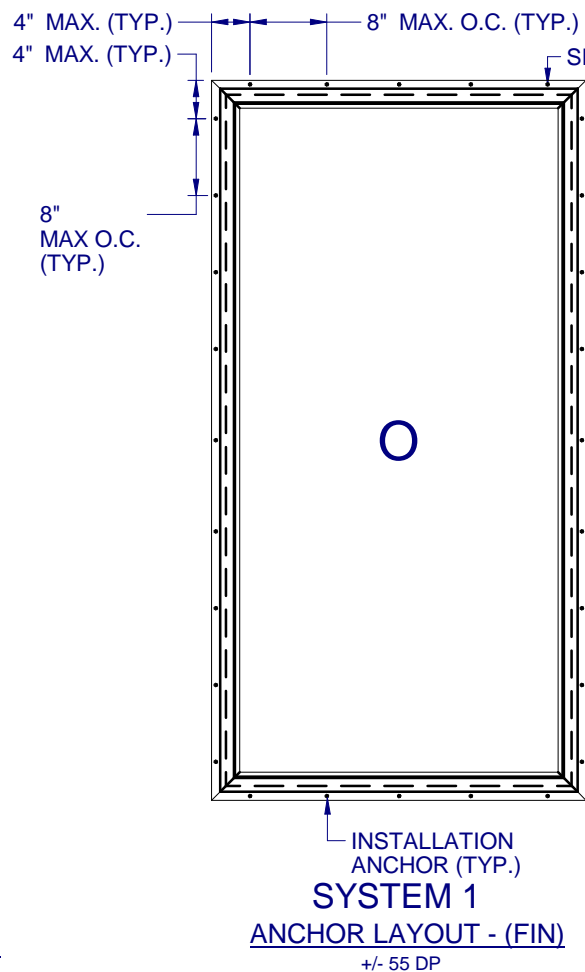
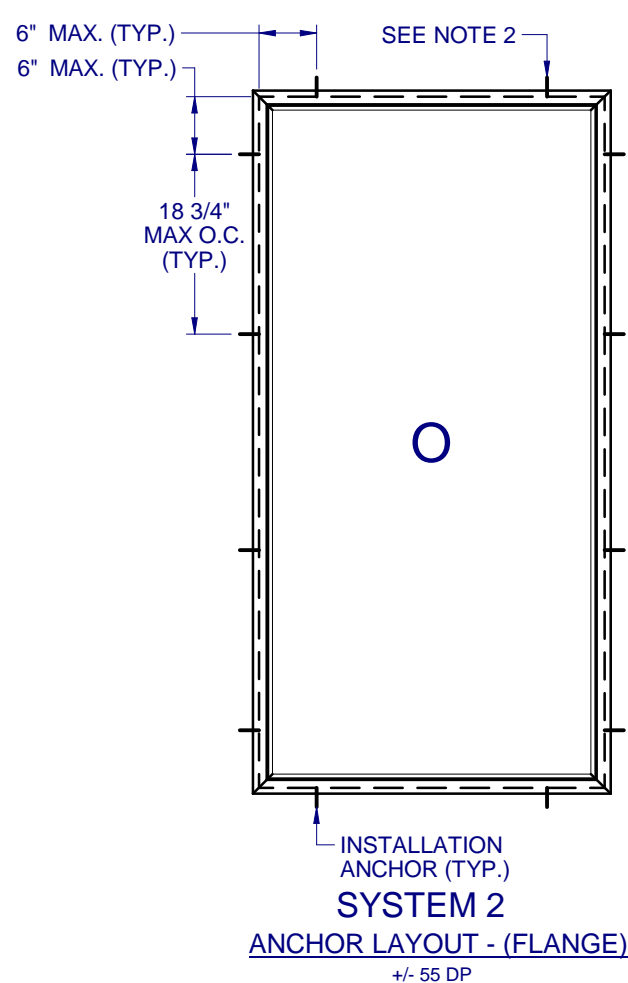

NOTES:

1. INSTALL ONE ANCHOR AT EACH INSTALLATION LOCATION. ANCHOR SPACING APPLIES TO ALL SHAPES (SEE SHEET 2) ALONG ALL FRAME EDGES. SILL ANCHOR SPACING SAME AS HEAD.
2. SHIM AS REQ AT EACH INSTALLATION ANCHOR USING LOAD BEARING SHIMS. MAX. ALLOWABLE SHIM STACK TO BE 1/4". USE SHIMS WHERE SPACE GREATER THAN 1/16" IS PRESENT. LOAD BEARING SHIMS SHALL BE CONSTRUCTED OF HIGH DENSITY PLASTIC OR BETTER. WOOD SHIMS ARE NOT ALLOWED.
3. ANCHOR TYPE, SIZE, SPACING AND EMBEDMENT SHALL BE AS SPECIFIED IN THESE DRAWINGS, SEE TABLE 1, SHEET 6.
4. ALL INSTALLATION ANCHORS MUST BE MADE OF OR PROTECTED WITH A CORROSION RESISTANT MATERIAL OR COATING. DISSIMILAR METALS OR MATERIALS IN CONTACT WITH PRESSURE TREATED WOOD MUST BE PROTECTED TO PREVENT REACTION.
5. INSTALLATION ANCHORS SHALL BE IN ACCORDANCE WITH ANCHOR MANUFACTURER'S INSTALLATION INSTRUCTIONS, AND ANCHORS SHALL NOT BE USED IN SUBSTRATES WITH STRENGTHS LESS THAN THE MINIMUM SPECIFIED IN TABLE 1, SHEET 6.
6. ANCHOR EMBEDMENT TO SUBSTRATE SHALL BE BEYOND WALL DRESSING OR STUCCO. FOR CONCRETE/CMU OPENINGS, EMBEDMENT SHALL BE BEYOND WOOD BUCKS, IF USED, INTO SUBSTRATE. INSTALLATIONS TO SOLID CONCRETE OR GROUT-FILLED CMU MAY INCLUDE BUT DO NOT REQUIRE 1X WOOD BUCKS BETWEEN THE PRODUCT AND SUBSTRATE. INSTALLATIONS TO HOLLOW CMU REQUIRE THE USE OF 1X BUCKS BETWEEN THE PRODUCT AND SUBSTRATE.
7. A MINIMUM CENTER-TO-CENTER SPACING SHALL BE MAINTAINED BETWEEN ALL FASTENERS: 3" FOR MASONRY, 1" FOR WOOD AND METAL.
8. WOOD OR MASONRY OPENINGS, BUCKS AND BUCK FASTENERS SHALL BE PROPERLY DESIGNED BY THE ARCHITECT OR ENGINEER OF RECORD AND INSTALLED TO TRANSFER WIND LOADS TO THE STRUCTURE. SUBSTRATES SHALL MEET THE MINIMUM STRENGTH REQUIREMENTS AS SHOWN IN TABLE 1, SHEET 6. CONCRETE AND MASONRY SUBSTRATES MAY NOT BE CRACKED.
9. SEALING AND FLASHING STRATEGIES FOR OVERALL WATER RESISTANCE OF INSTALLATION SHALL BE DONE BY OTHERS FOLLOWING THE CURRENT VERSION OF THE REFERENCE DOCUMENTS: FMA/AAMA 100(FIN WINDOWS), FMA/AAMA 200(FLANGE WINDOWS), FMA/WDMA 250(BOX WINDOWS), FMA/AAMA/WDMA 300(EXTERIOR DOORS)



**8300 PVC  
PICTURE WINDOW  
IMPACT**

NO.	DESCRIPTION:	BY:	DATE:
C	REVISED TO TDI REQUEST	MS	03/23/22
B	IBC/IRC REF. 2018 UPDATE	JLD	05/08/20
A	REVISED TO TDI REQUEST	JML	3/28/17

REVISIONS

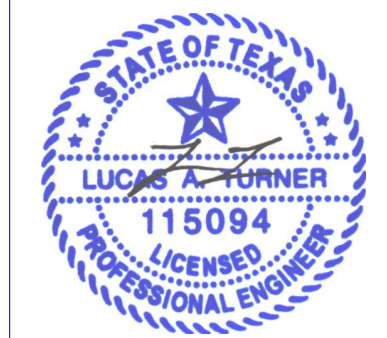

4/1/2022

LUCAS A. TURNER, P.E.  
TX PE # 115094  
TBPE REG. #F-18075  
2428 OLD NATCHEZ TRC TRL  
CAMDEN, TN 38320  
PH. 941-380-1574

SHEET DESCRIPTION:

**INSTALLATION DETAILS**

DRAWN BY:	DATE:
EMK	11/12/15
DWG #:	REV.:
TDI-1033	C
SCALE:	SHEET
1:2	6 OF 6

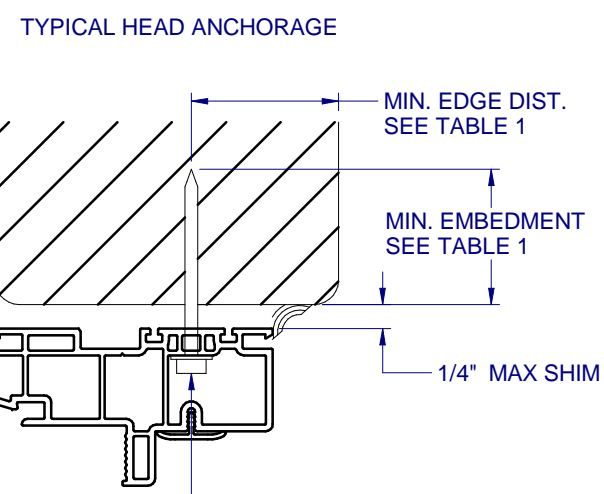

A VERTICAL SECTION  
6 TYPICAL SILL ANCHORAGE

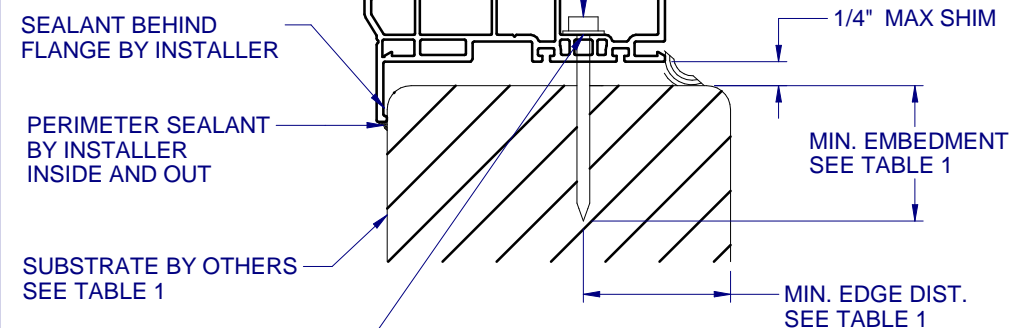

B HORIZONTAL SECTION  
6 TYPICAL JAMB ANCHORAGE

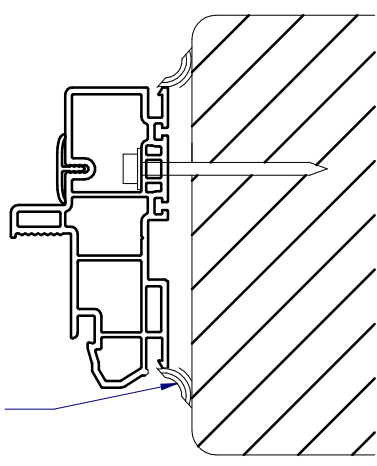

C HORIZONTAL SECTION  
6 TYPICAL FIN ANCHORAGE  
HEAD AND SILL SIMILAR FOR FIN INSTALLATION

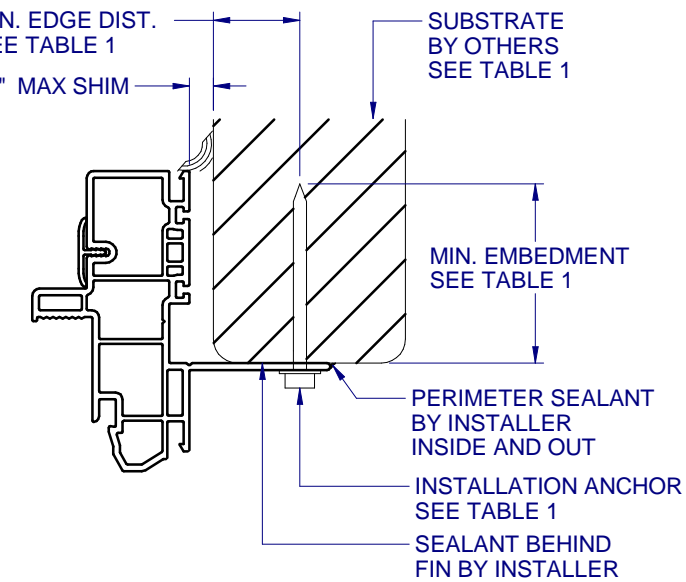

D HORIZONTAL SECTION  
6 BOX FRAME INSTALLATION  
HEAD AND SILL SIMILAR FOR BOX INSTALLATION

E HORIZONTAL SECTION  
6 TYPICAL FIN ANCHORAGE  
HEAD AND SILL SIMILAR FOR FIN INSTALLATION

TABLE 1: APPROVED INSTALLATION FASTENERS				
FRAME TYPE	SUBSTRATE TYPE	ANCHOR TYPE	MIN. EMBEDMENT	MIN. EDGE DIST.
FLANGE	CONCRETE (2.0 KSI MIN.)	3/16" ITW TAPCON	1-1/2"	1-1/8"
FLANGE	HOLLOW OR GROUT-FILLED CMU (117 PCF MIN.)	3/16" ITW TAPCON	1"	2"
FLANGE	CONCRETE (2.85 KSI MIN.)	3/16" ELCO ULTRACON	1"	1"
FLANGE	GROUT-FILLED CMU (ASTM C-90)	3/16" ELCO ULTRACON	1-1/4"	2-1/2"
FLANGE	2X MIN. SOUTHERN PINE (G=0.55)	3/16" ITW TAPCON OR ELCO ULTRACON	1-3/8"	7/8"
FLANGE	2X MIN. SOUTHERN PINE (G=0.55)	#10 WOOD SCREW	1-3/8"	7/8"
FLANGE	16 GAUGE (0.060") MIN. STEEL STUD (33 KSI YIELD MIN)	#10-16 HILTI KWIK-FLEX OR ITW TEKS SELF-DRILLING SCREW	FULL THREAD THRU 0.060"	7/16"
FLANGE	1/8" ALUM. (6063-T5 MIN.) OR 1/8" STEEL (33 KSI MIN.)	#10 GRADE 5 SELF-TAPPING / DRILLING SCREW	FULL THREAD THRU 0.125"	7/16"
FIN	2X MIN. SOUTHERN PINE (G=0.55)	#8 WOOD SCREW	1-1/2"	7/16"

FLANGE REMOVAL NOTE: PARTIALLY OR FULLY REMOVING THE FLANGE, UP TO AND INCLUDING A BOX-FRAME APPLICATION IS ACCEPTABLE PROVIDED:

- MIN. 1/4" FILLET OF CONSTRUCTION-GRADE ADHESIVE CAULK IS APPLIED INSIDE AND OUT, FULL PERIMETER, BY INSTALLER.
- PRODUCT ANCHORAGE IS IN ACCORDANCE WITH REQUIREMENTS AS SHOWN FOR FLANGE WINDOWS.