

NAIL FIN WITH CLIPS INSTALLATION DETAIL

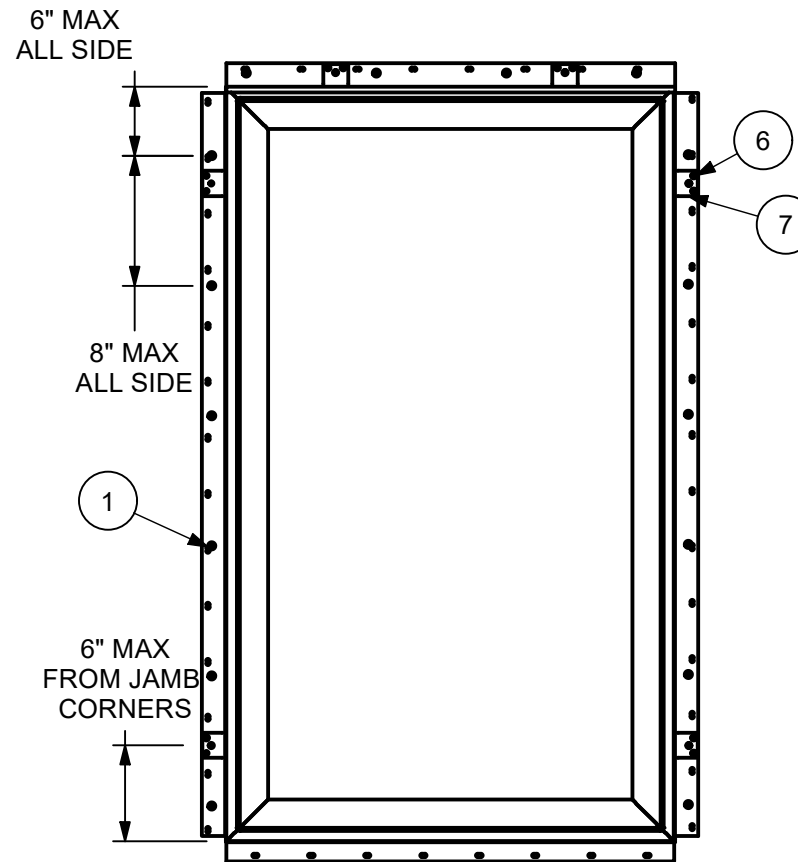

GLAZING DETAIL

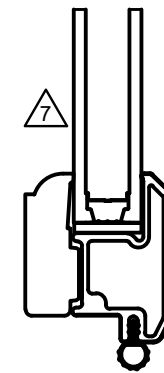

NAIL FIN WITH CLIPS INSTALLATION:

- SECURE NAIL FIN WITH 2" GALVANIZED ROOFING NAILS. MINIMUM OF TWO PER SIDE. SPACE PER THE ELEVATION.
- APPLY A 5/16" BEAD OF ASTM C920 GRADE NS, CLASS 25 SEALANT TO SILL/FRAMING
- ATTACH EACH CLIP TO THE UNIT WITH THREE #7 X 5/8" WOOD SCREWS
- ATTACH EACH CLIP TO THE FRAME WITH THREE 1-1/4" DRYWALL SCREWS
- TWO CLIPS PER JAMB REQUIRED ON UNIT SIZES LISTED IN NOTE 9

NOTES:

1. FOR GENERAL SPECIFICATIONS, REFER TO DOC 00003952
2. THIS PRINT IS FOR STRUCTURAL PERFORMANCE ONLY. FOR FLASHING & SEALING INSTRUCTIONS, REFER TO THE INSTALLATION INSTRUCTIONS
- △ 3. SHIMS:
 - PLACE SHIMS WITHIN 4" - 6" OF EACH CORNER AND SPACE ALL OTHERS EVENLY WITH A MAXIMUM OF 15" APART
4. IF CHEMICALLY TREATED LUMBER IS USED FOR FRAMING MATERIAL, FASTENERS INTO THE BUCK MUST BE A MINIMUM OF 0.90 OZ/FT² ZINC HOT DIPPED GALVANIZED OR STAINLESS STEEL TYPE 304 OR 316
- △ 5. MINIMUM NAIL EMBEDMENT DEPTH: 1-15/16"
- △ 6. MINIMUM EDGE DISTANCE: 1/2"
- △ 7. GLASS COMPLIES WITH ASTM E1300
8. FLORIDA PRODUCT APPROVAL: FL 9690 - ELCA P
- △ 9. NAIL FIN WITH CLIP INSTALLATION IS REQUIRED ON THE FOLLOWING ELCA P CALL NUMBERS: 5771 AND 7359 AND SPECIAL SIZES WITH ROW > 37.000" AND ROH > 47.625" OR ROW > 49.000 AND ROH >= 39.625

CATEGORY: CASEMENT **UNIT TYPE:** ELCAP, ELCATR

UNIT	MAX FRAME SIZE	DP RATING
ELCA P/TR	56 x 71-1/8	+50/-50
ELCA P/TR	72 X 59-1/8	+50/-50

ITEM	DWG NO	DESCRIPTION
9	NA	ASTM C920 GRADE NS CLASS 25 SEALANT
8	00003212	#7-19 X .625" TYPE AB-17, FULL THREAD
7	00050381	STATIONARY INSTALLATION CLIP
6	NA	1-1/4" DRYWALL SCREW
5	NA	FRAMING MATERIAL
4	NA	SHEATHING
3	NA	SHIMS
2	NA	5/8 X 3.500" FILLER BY CONTRACTOR
1	NA	2.000" GAL. ROOF NAIL

PARTS LIST

MARVIN RESEARCH & DEVELOPMENT

COLLECTION: ELEVATE

DWG TYPE: INSTALLATION
 DESCRIPTION: INSTALLATION METHODS/ELEVATIONS, NAIL FIN WITH CLIPS, FL 9690

CHK: JDD	SIZE: B	CLASS: MISC	DWG NO: 00051284
APP: CRR	SCALE: 1 / 10	DATE: 2/14/2012	DWG BY: HEPPNER, CALEB
			SHEET: 1 OF 2

REV	DESCRIPTION / REQUESTOR	ECN NO	DATE	REV BY
3.2	REMOVED NAIL FIN INSTALLATION, ADDED MAX FRAME SIZE TABLE, ADDED GLAZING DETAIL	27207	02/07/23	JH

NOTICE - CONFIDENTIAL INFORMATION

The information in this document is privileged and strictly confidential. The information contained herein shall be used only by Marvin employees and by those agents or suppliers granted official written permission. If the reader of this document is not the intended recipient, or the employee or agent of the intended recipient, please delete this document from all data storage devices, and destroy all hard copies. Any unauthorized dissemination, distribution, copying or other use of the information contained in this document is strictly prohibited.