

Product Evaluation

RC218 | 0220

Engineering Services Program

The following product has been evaluated for compliance with the wind loads specified in the International Residential Code (IRC) and the International Building Code (IBC).

This product evaluation is not an endorsement of this product or a recommendation that this product be used. The Texas Department of Insurance has not authorized the use of any information contained in the product evaluation for advertising, or other commercial or promotional purpose.

This product evaluation is intended for use by those individuals who are following the design wind load criteria in Chapter 3 of the IRC and Section 1609 of the IBC. The design loads determined for the building or structure shall not exceed the design load rating specified for the products shown in the limitations section of this product evaluation. This product evaluation does not relieve a Texas licensed engineer of his responsibilities as outlined in the Texas Insurance Code, the Texas Administrative Code, and the Texas Engineering Practice Act.

For more information, contact TDI Engineering Services Program at (800) 248-6032.

Evaluation ID: RC-218

Effective Date: February 1, 2020

Re-evaluation Date: February 2024

Product Name: DMC 175S .040 Aluminum Standing Seam Roofing Panels Installed Over a Plywood Deck

Manufacturer: Drexel Metals, Inc.
1234 Gardener Lane
Louisville, KY 40213
(888) 321-9630

General Description:

The aluminum standing seam metal roofing panels have 17-1/2" of coverage. The standing seam metal roof panels have a 1-3/4" rib height and a female rib that snaps over the male rib locking the panels together. The metal roofing panels are manufactured from 0.040" thick aluminum. Refer to Figure 1 for an illustration of the DMC 175S standing seam panel.

Limitations:

Roof Framing: The metal roofing panels must be installed over a solidly sheathed minimum 15/32" plywood roof deck. Roof framing spacing not to exceed 24" on center.

New Roof Framing Attachment: The roof framing must meet or exceed the uplift requirements of the IRC or IBC and must be installed as required for resistance to wind loads.

Design Wind Pressures: The design pressure uplift load resistance must be as specified in Table 1.

Roof Slope: The metal roofing panels may be installed on roofs with a roof slope as low as 2:12.

Installation Over an Existing Roof Covering: Installation over an existing roof covering is limited to a maximum of one existing layer of composition shingles, wood shingles or shakes, built-up roofing, or roll roofing applied over an existing, solid roof deck of minimum 15/32" plywood. Note: Inspection of the existing roof deck must be made prior to the installation of the roof panels. The condition of the existing roof deck must be acceptable to receive the metal roofing panels before the metal roofing panel installation proceeds. NOTE: Underlayment is required to be installed.

Table 1. Attachment of DMC 175S to Aluminum Standing Seam Roofing to Plywood Deck

Design wind pressure	Clip Fasteners	Clip Spacing
-106.75 psf	Two (2) No. 10 x 1"	18" o.c.

Installation:

General: The metal roofing panels must be installed in accordance with the manufacturer's recommended installation instructions and this evaluation report.

Panels: The metal roofing panels must be secured to the roof framing as specified in Table 1 and in accordance with this section.

Deck: The roof deck must be solidly sheathed with minimum 15/32" plywood.

Underlayment: Minimum of one layer of No. 30 (Type II) asphalt felt must be used. The underlayment used must comply with one or more of the following: ASTM D 226, ASTM D 4869, or ASTM D 1970. The underlayment must be installed with minimum 4-inch side laps and 6-inch end laps. The underlayment must be applied with corrosion resistant tin caps and minimum 12 gauge 1-1/4" annular ring shank nails. The fasteners must be spaced 6" on center at all end laps and two staggered rows 12" on center in the field.

Alternative Underlayment: Either a synthetic underlayment or a peel and stick ice and water shield that complies with the requirements for underlayment as specified in the IRC and the IBC. The underlayment must be installed per the manufacturer's installation instructions.

Attachment of Metal Roof Panels to the Roof Deck: The metal roofing panels must be secured to the roof deck with DMC 175S snap lock fixed clips. Refer to Figure 1 for an illustration of the snap lock fixed clip. The snap lock fixed clip is 18-gauge L-shaped galvanized steel that is 2" wide, 1-7/8" high, and 3-3/4" long. Each DMC 175S snap lock fixed clip is secured to the roof deck with two (2) minimum No. 10 x 1" long pancake head screws as indicated in Table 1. The fasteners must be long enough to ensure a minimum penetration of 1/4" below the roof deck. (Note: If the metal roofing panels are installed over an existing roof covering, then the fastener length must

be increased so that the fasteners are long enough to ensure a minimum penetration of 1/4" below the existing plywood roof decking.) The snap lock fixed clips must be located approximately 3" from each end and 18" on center as indicated in Table 1. The adjoining panels are snap locked into place.

Panel Ends and End Laps: As required by the manufacturer.

Panel Edges: As required by the manufacturer.

Trims, Closures, and Accessories: Components, such as the eave trim, rake trim, ridge trim, hip trim, and valley trim must be installed as required by the manufacturer.

Note: Keep the manufacturer's installation instructions available on the job site during the installation. Use corrosion resistant fasteners as specified in the IRC and the IBC.

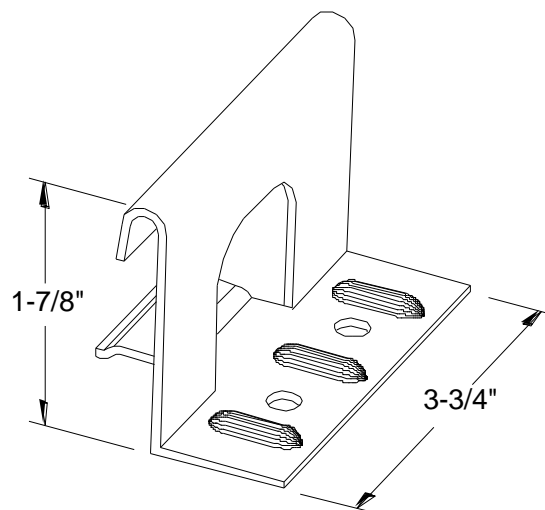
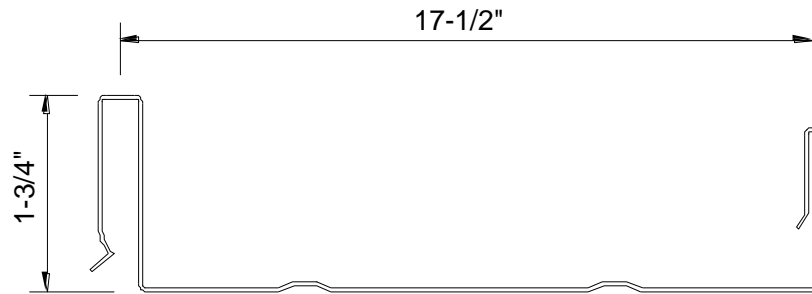

Figure 1. DMC 175S Standing Seam Panel Profile and Snap Lock Fixed Clip