

## Product Evaluation

RC172 | 0220

Engineering Services Program

The following product has been evaluated for compliance with the wind loads specified in the International Residential Code (IRC) and the International Building Code (IBC).

This product evaluation is not an endorsement of this product or a recommendation that this product be used. The Texas Department of Insurance has not authorized the use of any information contained in the product evaluation for advertising, or other commercial or promotional purpose.

This product evaluation is intended for use by those individuals who are following the design wind load criteria in Chapter 3 of the IRC and Section 1609 of the IBC. The design loads determined for the building or structure shall not exceed the design load rating specified for the products shown in the limitations section of this product evaluation. This product evaluation does not relieve a Texas licensed engineer of his responsibilities as outlined in the Texas Insurance Code, the Texas Administrative Code, and the Texas Engineering Practice Act.

For more information, contact TDI Engineering Services Program at (800) 248-6032.

**Evaluation ID:** RC-172

**Effective Date:** February 1, 2020

**Re-evaluation Date:** February 2024

**Product Name:** 24 Gauge Tech Snap 1750 Steel Roofing Panel Installed over a Wood Structural Panel Deck

**Manufacturer:** R. B. Hash & Associates, Inc.  
8619 Derrington  
Houston, TX 77064  
(713) 463-9800  
www.rbhash.com

### General Description:

The 24-gauge Tech Snap 1750 metal roofing panels have a 16" coverage. The metal roofing panels have a 1-3/4" high rib with a snap lock seam. The metal roofing panels are manufactured from 24-gauge Galvalume Plus coated steel conforming to ASTM A792, Grade 50, with a minimum yield strength of 50 ksi. The metal roofing panels can be painted with a Kynar 500 finish coating. Figure 1 illustrates a profile view of the metal roofing panel.

### Limitations:

**Roof Deck:** The metal roofing panels must be installed over minimum 15/32" plywood decking.

**New Roof Deck Attachment:** The roof decking must meet or exceed the uplift requirements of the IRC or IBC and must be installed as required for resistance to lateral wind loads.

**Design Wind Pressures:** The design pressure uplift load resistance must be as specified in Table 1.

**Table 1.** 24 Gauge Tech Snap 1750 Steel Roofing Panel Installed over a Wood Structural Panel Deck

Design Wind Pressure	Clip Fasteners	Clip Spacing
-86.0 psf	Two (2) No. 10-13 x 1"	24"
-108.5 psf	Two (2) No. 10-13 x 1"	6"

**Installation Over an Existing Roof Covering:** Installation over an existing roof covering is limited to a maximum of one existing layer of composition shingles, wood shingles or shakes, built-up roofing, or roll roofing applied over an existing, solid roof deck of minimum 15/32 inch plywood. Note: Inspection of the existing roof deck must be made prior to the installation of the roof panels. The condition of the existing roof deck must be acceptable to receive the metal roofing panels before the metal roofing panel installation proceeds. NOTE: Underlayment is not required to be installed.

**Roof Slope:** The metal roofing panels may be installed on roofs with a roof slope as low as 3:12.

**Installation:**

**General:** The metal roofing panels must be installed in accordance with the manufacturer's recommended installation instructions and this product evaluation report.

**Panels:** The metal roofing panels must be secured to the roof deck as specified in Table 1 and in accordance with this section.

**Underlayment:** A minimum of one layer of No. 15 (Type I) asphalt felt must be used. The underlayment used must comply with one or more of the following: ASTM D 226, ASTM D 4869, or ASTM D 1970. The underlayment must be installed with 6" side laps and 3" end laps. The underlayment must be applied with corrosion-resistant fasteners in accordance with the manufacturer's installation instructions. Fasteners must be applied along the overlaps not farther apart than 36" on center.

**Attachment of metal roof panels to Roof Deck:** The metal roofing panels must be secured to the roof deck as follows:

**Roofing Panels:** Minimum No. 10-13" x 1" GP Pancake screws, manufactured by Triangle Fastener with 2" long SG-178-18 galvanized steel panel installation clips by Logan Stamping, Inc. Figure 2 illustrates the panel installation clip. The fasteners must be long enough to ensure a minimum penetration of 1/4" below the roof deck. (Note: If the metal roofing panels are installed over an existing roof covering, then the fastener length must be increased so that the fasteners are long

enough to ensure a minimum penetration of 1/4" below the existing plywood roof decking.) The required size and quantity of fasteners as well as the maximum allowable spacing of the clips is specified in Table 1.

**Trims, closures, and accessories:** Components, such as the eave trim, rake trim, ridge trim, and valley trim must be installed as required by the manufacturer.

**Alternative Fasteners:** Substitution of equivalent fasteners must meet the following requirements:

No. 10-13 x 1" GP Pancake, manufactured by Triangle Fastener

- Ultimate withdrawal (pullout)  $\geq$  350 lbs. in minimum 15/32" plywood.

**Note:** Keep the manufacturer's installation instructions available on the job site during the installation. Use corrosion resistant fasteners as specified in the IRC and the IBC.

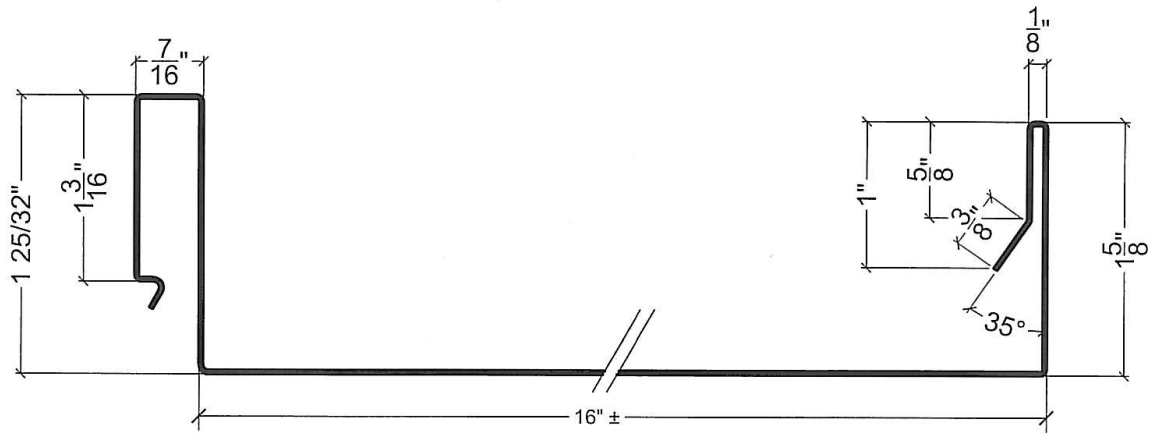
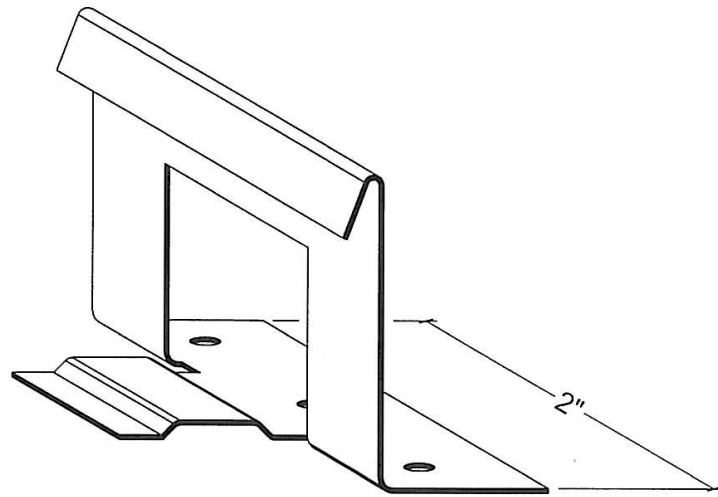

Figure 1. Tech Snap 1750 Panel – Profile



PANEL ATTACHMENT CLIP N.T.S.  
LOGAN STAMPINGS INC.  
SG-178-18

Figure 2. Tech Snap 1750 Panel Attachment Clip