

Product Evaluation

RC185 | 0121

Engineering Services Program

The following product has been evaluated for compliance with the wind loads specified in the International Residential Code (IRC) and the International Building Code (IBC).

This product evaluation is not an endorsement of this product or a recommendation that this product be used. The Texas Department of Insurance has not authorized the use of any information contained in the product evaluation for advertising, or other commercial or promotional purpose.

This product evaluation is intended for use by those individuals who are following the design wind load criteria in Chapter 3 of the IRC and Section 1609 of the IBC. The design loads determined for the building or structure shall not exceed the design load rating specified for the products shown in the limitations section of this product evaluation. This product evaluation does not relieve a Texas licensed engineer of his responsibilities as outlined in the Texas Insurance Code, the Texas Administrative Code, and the Texas Engineering Practice Act.

For more information, contact TDI Engineering Services Program at (800) 248-6032.

Evaluation ID: RC-185

Effective Date: January 1, 2021

Re-evaluation Date: January 2025

Product Name: Sturdi-Rib X Steel Roof Panels

Manufacturer: Whirlwind Building Components
8234 Hansen Road
Houston, TX 77075
(713) 946-7140

General Description:

The Sturdi-Rib X metal roofing panels have 36" of coverage. The metal roof panels have a 3/4" rib height. The metal roof panels are manufactured from minimum 29-gauge Galvalume coated steel that conform to ASTM A792, Grade 80, with a minimum yield strength of 80,000 psi. The metal roofing panels can be painted with Kynar 500 Fluoropolymer finish coating.

Limitations:

Roof Framing: The metal roofing panels must be installed over one of the following types of roof framing:

- Minimum 15/32" plywood roof deck,
- Minimum 7/16" Oriented Strand Board (OSB) roof deck,
- Minimum 1x4 No. 2 Southern Yellow Pine wood purlins

New Roof Framing Attachment: The roof framing must meet or exceed the uplift requirements of the IRC or IBC and must be installed as required for resistance to wind loads.

Design Wind Pressures: The design pressure uplift load resistance must be as specified in Tables 1-3.

Roof Slope: The metal roofing panels may be installed on roofs with a roof slope as low as 3:12. If applied lap sealant is used, then the minimum roof slope is 1/2:12.

Table 1

Attachment of Minimum 29-gauge Sturdi-Rib X Steel Roofing Panels to Minimum 15/32" Plywood Roof Deck.

Design Wind Pressure (psf)	Attachment of Roof Panel to 15/32" Plywood
-52.5 psf	Fastener Pattern No. 1 @ 30" o.c.
-138.5 psf	Fastener Pattern No. 2 @ 18" o.c.

Table 2

Attachment of Minimum 29-gauge Sturdi-Rib X Steel Roofing Panels to Minimum 7/16" OSB Roof Deck.

Design Wind Pressure (psf)	Attachment of Roof Panel to 7/16" Oriented Strand Board (OSB)
-20.8 psf	Fastener Pattern No. 1 @ 24" o.c.
-50.0 psf	Fastener Pattern No. 1 @ 18" o.c.
-79.3 psf	Fastener Pattern No. 1 @ 12" o.c.
-108.5 psf	Fastener Pattern No. 1 @ 6" o.c.

Table 3

Attachment of Minimum 29-gauge Sturdi-Rib X Steel Roofing Panels to Minimum 1x4 No. 2 Southern Yellow Pine Wood Purlins.

Design Wind Pressure (psf)	Attachment of Roof Panel to 1 x 4" Wood Purlins	Attachment of 1 x 4" Wood Purlins to Southern Pine Truss/Rafter
-78.5 psf	Fastener Pattern No. 1 with purlins spaced at 24" o.c.	Two No. 9 x 2-1/2" deck screws (2 screws per purlin)
-97.3 psf	Fastener Pattern No. 1 with purlins spaced at 18" o.c.	Two No. 9 x 2-1/2" deck screws (2 screws per purlin)
-116.0 psf	Fastener Pattern No. 1 with purlins spaced at 12" o.c.	Two No. 9 x 2-1/2" deck screws (2 screws per purlin)

Installation Over an Existing Roof Covering: Installation over an existing roof covering is limited to a maximum of one existing layer of composition shingles, wood shingles or shakes, built-up roofing, or roll roofing applied over an existing, solid roof deck of minimum 15/32" plywood or

7/16" OSB. Note: Inspection of the existing roof deck must be made prior to the installation of the roof panels. The condition of the existing roof deck must be acceptable to receive the metal roofing panels before the metal roofing panel installation proceeds. **Note:** Underlayment is not required to be installed.

Installation:

General: The metal roofing panels must be installed in accordance with the manufacturer's recommended installation instructions and this evaluation report.

Panels: The metal roofing panels must be secured to the roof framing as specified in Tables 1-3 and in accordance with this section.

Wood Purlins: The wood purlins must be secured to minimum Southern Yellow Pine rafters or trusses roof framing using minimum No. 9 x 2-1/2" Deckmate screws as specified in Table 3 for 1x4 purlins. The fasteners must be long enough to ensure a minimum penetration of 1-3/4" into the roof framing. Roof framing must not exceed 24" O.C.

Underlayment: For installations over a solid deck, a minimum of one layer of No. 30 (Type II) asphalt felt must be used. The underlayment used must comply with one or more of the following: ASTM D 226, ASTM D 4869, or ASTM D 1970. The underlayment must be installed with 6" side laps and 3" end laps. The underlayment must be applied with corrosion resistant roofing nails in accordance with the manufacturer's installation instructions. Fasteners must be applied along the overlaps a maximum of 36" on center.

Attachment of Metal Roof Panels to the Roof Deck: The metal roofing panels must be secured to the roof framing in one of the following ways:

Roofing Panels to Plywood Deck: Minimum SFS intec, Inc. No. 10-15 x 1-1/2" long, HiLo Woodgrip screws with washers or approved equal. The fasteners must be long enough to ensure a minimum penetration of 1/4" below the roof deck. (Note: If the metal roofing panels are installed over an existing roof covering, then the fastener length must be increased so that the fasteners are long enough to ensure a minimum penetration of 1/4" below the existing plywood roof deck.) The required fastener pattern and maximum allowable spacing of the fastener lines is specified in Table 1. Refer to Figure 1 for illustrations of the fastener patterns.

Roofing Panels to OSB Deck: Minimum No. 10-14 x 1-1/2" long, Atlas WoodTite HWH screws with sealing washers or approved equal. The fasteners must be long enough to ensure a minimum penetration of 1/4" below the roof deck. (Note: If the metal roofing panels are installed over an existing roof covering, then the fastener length must be increased so that the fasteners are long enough to ensure a minimum penetration of 1/4" below the existing plywood roof deck.) The required fastener pattern and maximum allowable spacing of the fastener lines is specified in Table 2. Refer to Figure 2 for illustrations of the fastener patterns.

Roofing Panels to the 1x4 Wood Purlins: Minimum No. 10-14 x 1-1/2" long, Atlas WoodTite HWH screws with sealing washers or approved equal. The required fastener pattern, the maximum allowable spacing of the fastener lines, and the attachment of the purlins to the roof framing is specified in Table 3. Refer to Figure 3 for illustrations of the fastener patterns.

Trims, Closures, and Accessories: Components, such as the eave trim, rake trim, ridge trim, hip trim, and valley trim must be installed as required by the manufacturer.

Alternative Fasteners: Alternative fasteners of equal or greater strength may be substituted.

Note: Keep the manufacturer's installation instructions available on the job site during the installation. Use corrosion resistant fasteners as specified in the IRC and the IBC.

FASTENER PATTERN #1

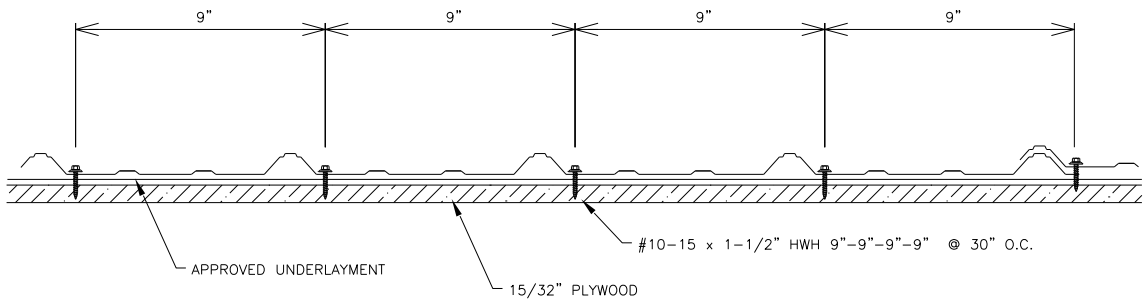

FASTENER PATTERN #2

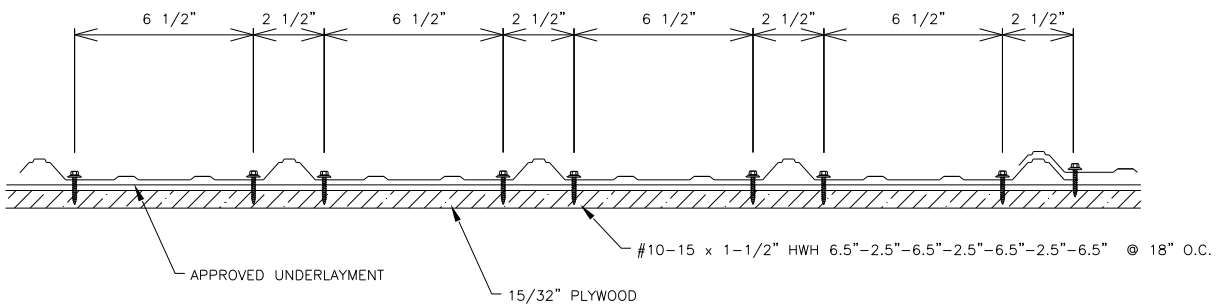

Figure 1: Sturdi-Rib X Metal Roofing Panel Secured to a 15/32" Plywood Deck

FASTENER PATTERN #1

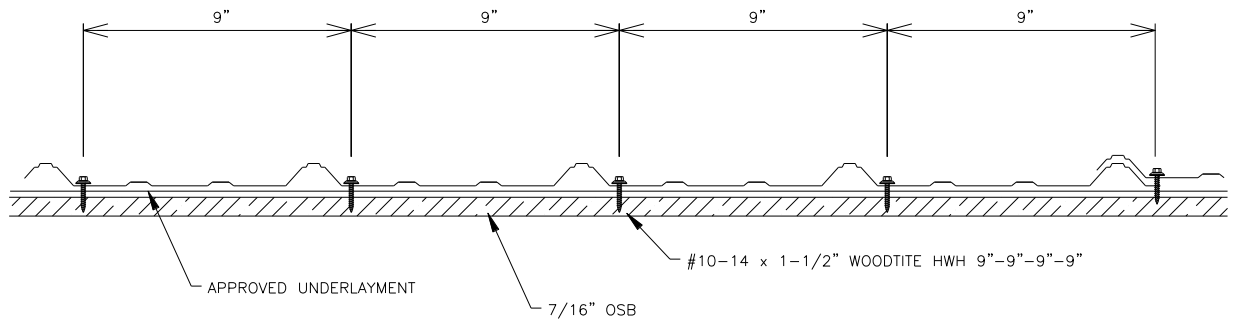

Figure 2: Sturdi-Rib X Metal Roofing Panel Secured to a 7/16" OSB Deck

FASTENER PATTERN #1

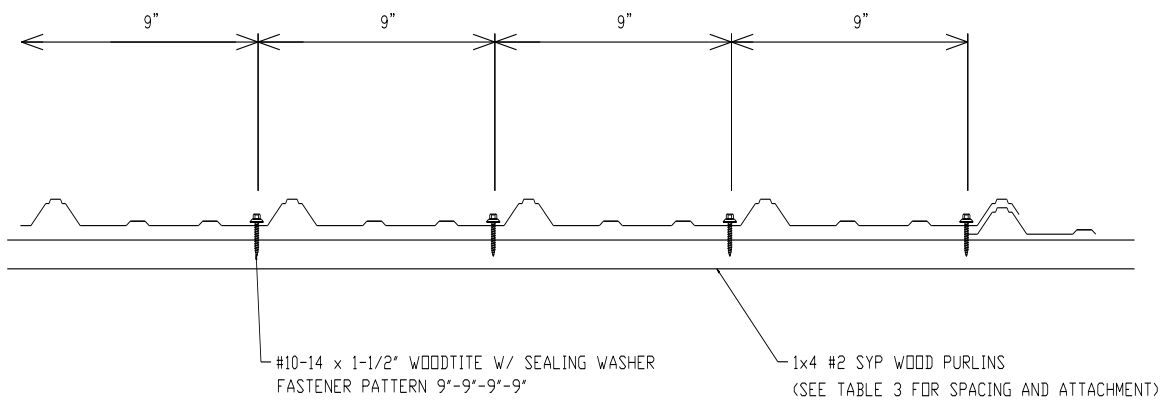

Figure 3: Sturdi-Rib X Metal Roofing Panel Secured to 1x4 Wood Purlins