

- NOTES:**
- NON-IMPACT REISTANT GLAZING OPTION - .090" MINIMUM SSB GLAZING IN MOLDED FRAMES SCREWED TOGETHER WITH A MINIMUM OF (10) #8x1" SCREWS (3X ALONG THE HORIZONTAL AND 2X ALONG THE VERTICAL) INSTALLED IN TOP OR INTERMEDIATE SECTION (WITH OR WITHOUT DECORATIVE INSERTS) MEETS UNIFORM STATIC WIND PRESSURES SHOWN ON THIS DRAWING. MAXIMUM GLAZING DIMENSIONS SHALL BE 15" x 46" CUTOUT. GLAZING IS NOT IMPACT RESISTANT AND DOES NOT MEET THE REQUIREMENTS FOR WIND-BORNE DEBRIS REGIONS.
  - VINYL OR WOOD DOOR STOP NAILED A MAXIMUM OF 6" O.C. MUST OVERLAP TOP AND BOTH ENDS OF PANELS MINIMUM 7/16" TO MEET NEGATIVE PRESSURES.
  - KEY LOCK, SLIDE LOCK, OR OPERATOR REQUIRED.
  - LOUVER OPTION - .040" MINIMUM LOUVERS IN MOLDED FRAMES SCREWED TOGETHER WITH A MINIMUM OF (10) #8x1" SCREWS (3X ALONG THE HORIZONTAL AND 2X ALONG THE VERTICAL) INSTALLED IN THE BOTTOM SECTION. MAXIMUM LOUVER DIMENSIONS SHALL BE 15" x 19" CUTOUT. LOUVERS ARE NOT IMPACT RESISTANT AND DO NOT MEET THE REQUIREMENTS FOR WIND-BORNE DEBRIS REGIONS.
  - FACER STEEL TO HAVE A MINIMUM 27 GA THICKNESS AND BACKER STEEL TO HAVE A MINIMUM 29 GA THICKNESS.
  - A 4-1/2" x 6" x 22 GA BACKER PLATE IS TO BE LOCATED AT EVERY INTERMEDIATE AND OUTER END HINGE LOCATION.
  - THE DESIGN OF THE SUPPORTING STRUCTURAL ELEMENTS SHALL BE THE RESPONSIBILITY OF THE PROFESSIONAL OF RECORD FOR THE BUILDING OR STRUCTURE AND IN ACCORDANCE WITH CURRENT BUILDING CODES FOR THE LOADS LISTED ON THIS DRAWING.
  - DOOR JAMB TO BE MINIMUM 2x4 STRUCTURAL GRADE LUMBER. REFER TO JAMB CONNECTION SUPPLEMENT FOR ATTACHMENT TO SUPPORTING STRUCTURE.
  - FOR LOW HEAD ROOM LIFT CONDITIONS, TOP BRACKET SHALL BE A 13 GA LHR 7/4 TOP BRACKET WITHOUT PUSHNUTS AND WITH A MINIMUM OF (3) 1/4-14x7/8" SELF DRILLING CRIMPTITE SCREWS IN LIEU OF THE BRACKET SHOWN ON THIS DRAWING. U-BAR ON TOP SECTION SHALL BE INSTALLED ON TOP OF LHR TOP BRACKETS.

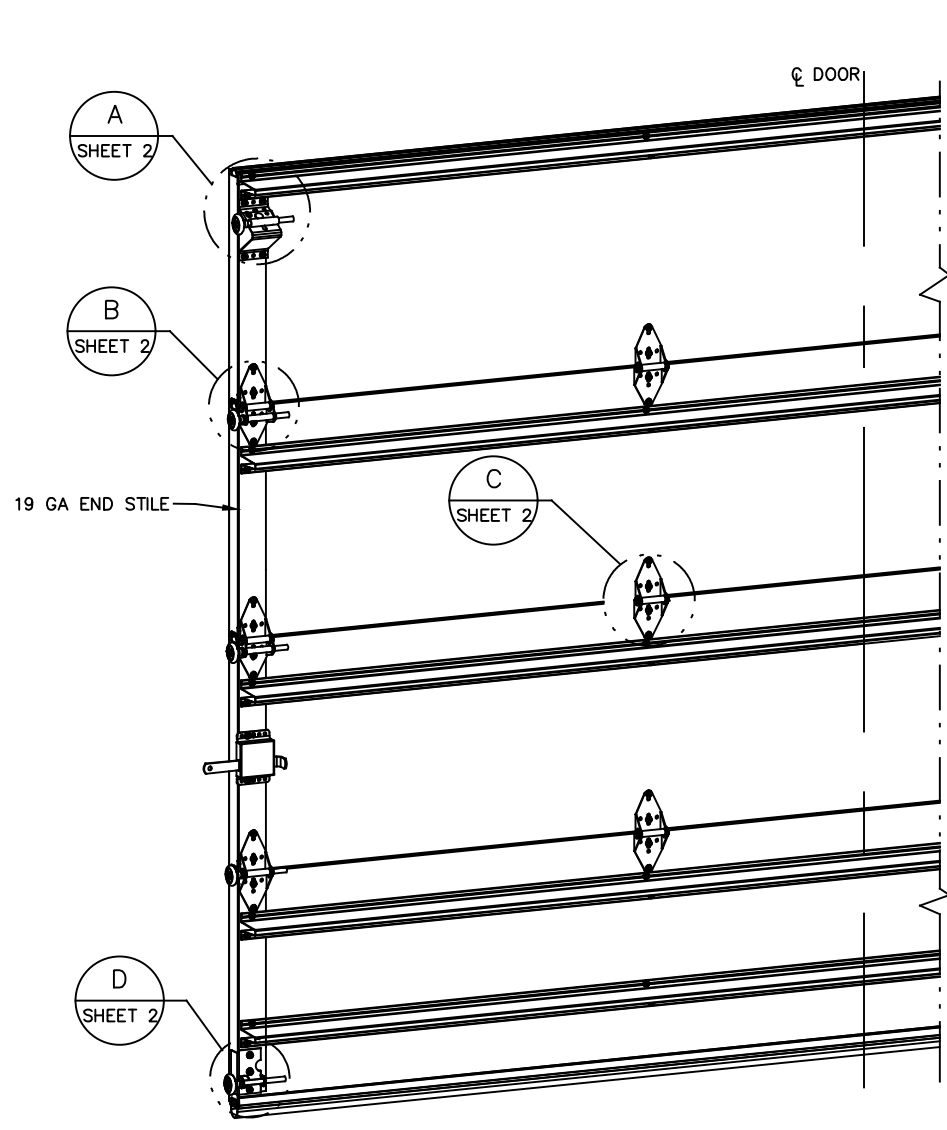
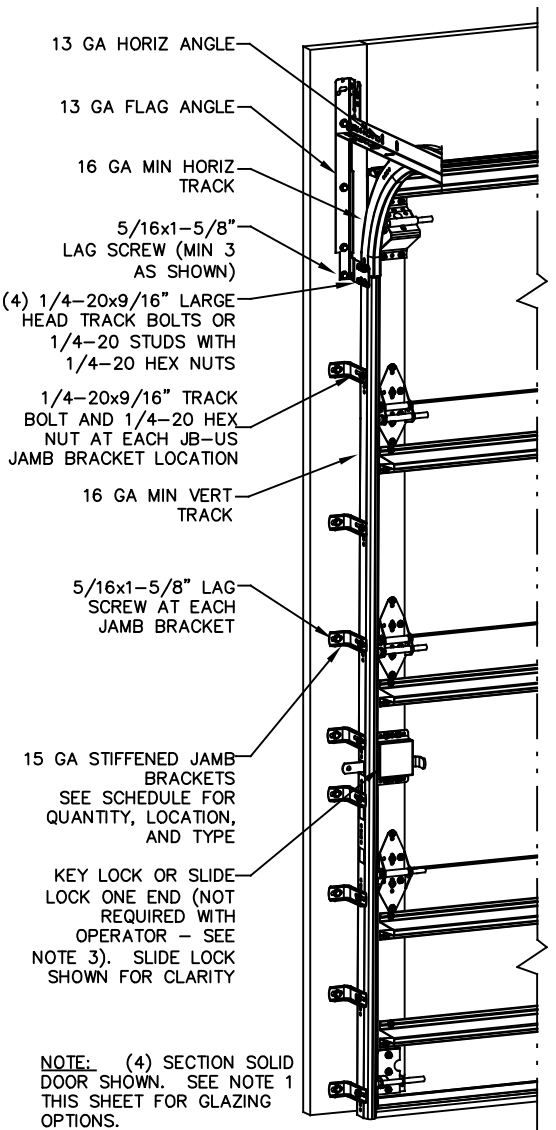

REVISIONS				
ER	REV	DESCRIPTION	DATE	APPROVAL
	-	RELEASE PER NPD0054	02/04/20	TLC
	A	UPDATED DRAWING	04/08/20	TLC
32442	B	ADDED NYLON ROLLER OPT	9/5/20	TLC
32442	C	ADDED IRC/IBC NOTE	8/19/20	TLC

SUPERIMPOSED DESIGN PRESSURE LOADS ON SUPPORTING STRUCTURE		
DOOR WIDTH	DOOR HEIGHT	UNIFORM LOAD EACH JAMB (PLF)
6'-6"	ALL	+98.1/-109.8
7'-0"	ALL	+98.1/-109.8
7'-6"	4 OR 5	+117.4/-131.4
8'-0"	4 OR 5	+117.4/-131.4
12'-2"	ALL	+117.4/-131.4

JAMB BRACKET SCHEDULE			
DOOR HEIGHT	NO. OF SECTIONS	NO. OF JAMB BRACKETS (EACH JAMB)	LOCATION OF CENTERLINE OF JAMB BRACKETS MEASURED FROM BOTTOM OF TRACK (ALL DIMENSIONS ± 2")
6'-6"	4	7	2" (JB-US), 10" (JB-US), 21-3/4" (JB-US), 29-3/4" (JB-US), 39" (JB-US), 48" (JB-US), 57-1/4" (JB-US)
7'-0"	4	7	2" (JB-US), 10" (JB-US), 21-3/4" (JB-US), 29-3/4" (JB-US), 42" (JB-US), 52-1/2" (JB-US), 63-1/4" (JB-US)
7'-6"	4 OR 5	8	2" (JB-US), 10" (JB-US), 18-3/4" (JB-US), 26-3/4" (JB-US), 36" (JB-US), 45" (JB-US), 54-1/4" (JB-US), 74-1/2" (JB-US)
8'-0"	4 OR 5	8	2" (JB-US), 10" (JB-US), 21-3/4" (JB-US), 29-3/4" (JB-US), 39" (JB-US), 48" (JB-US), 57-1/2" (JB-US), 75-1/2" (JB-US)
> 8'-0"			SEE NOTE BELOW

NOTE:  
(JB-US) FOLLOWING DIMENSION DENOTES SLOTTED JAMB BRACKET ATTACHED TO TRACK WITH 1/4-20x9/16" TRACK BOLT AND NUT AS SHOWN ABOVE.  
ALL DOORS GREATER THAN 8' IN HEIGHT REQUIRE USE OF CONTINUOUS WALL ANGLE. SEE SUPPLEMENT TRACK CHART FOR DETAILS.

STATIC PRESSURE RATINGS	APPROVED SIZES
DESIGN PRESSURE(PSF): +19.3/-21.6	MAX WIDTH: 12'-2" MAX HEIGHT: 24'
IMPACT/CYCLIC RATED: NO	MAX SECTION HEIGHT: 24'

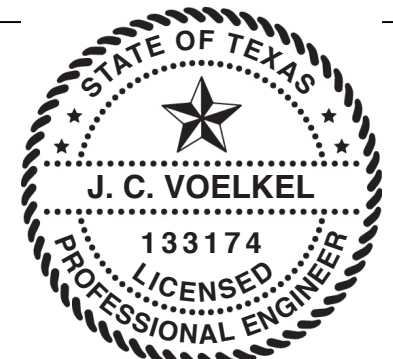

J. CHRISTIAN VOELKEL, PE  
312 N. NEW WARRINGTON RD, UNIT 1A  
PENSACOLA, FL  
FL PE 82229  
TX PE 133174

PROFESSIONAL ENGINEER'S SEAL PROVIDED ONLY FOR VERIFICATION OF WIND LOAD CONSTRUCTION DETAILS.

THE DOORS ARE DESIGNED AND MANUFACTURED TO COMPLY WITH THE 2018 IRC AND THE 2018 IBC.

THE DRAWINGS AND ALL OTHER INFORMATION CONTAINED HEREIN ARE THE CONFIDENTIAL AND PROPRIETARY PROPERTY OF OVERHEAD DOOR CORPORATION AND ITS AFFILIATED COMPANIES. THIS DRAWING AND INFORMATION, IN WHOLE OR IN PART, MAY NOT BE COPIED IN ANY MANNER OR DISCLOSED TO ANYONE WITHOUT THE PRIOR WRITTEN CONSENT OF OVERHEAD DOOR CORPORATION. NO DISCLOSURE OF ANY OF THIS DRAWING OR INFORMATION IS INTENDED TO OPERATE AS A LICENSE OR AUTHORIZATION TO USE IT FOR ANY PURPOSE WITHOUT THE SPECIFIC WRITTEN CONSENT OF OVERHEAD DOOR CORPORATION.											
REF DWG	USED ON	THIRD ANGLE PROJECTION	TOLERANCES UNLESS OTHERWISE SPECIFIED		FINISH	The Genuine. The Original.		NAME	DATE		
			HOLE DIAMETER	WHOLE NUMBERS:	N/A	OVERHEAD DOOR		T. CLARK	02/04/20		
			UNDER .251 +.004/-0.003	± .25	UNIT OF MEASURE	LEWISVILLE, TEXAS		DRAWING TITLE:	SERIES 5745/5765/7565 7655/515/525		
			.251 TO .500 +.006/-0.003	.X ± .1		MATERIAL:	APPROVED BY:			DRAWING NUMBER	
			OVER .500 +.008/-0.003	.XX ± .03 .XXX ± .010			NONE				D-411621
			FRACTIONS	ANGLES:	EACH			SCALE:	N.T.S.   SHEET 1 OF 2		
			± 1/16	± .5°							

REVISIONS				
ER	REV	DESCRIPTION	DATE	APPROVAL
	-	RELEASE PER NPD0054	02/04/20	TLC
	A	UPDATED DRAWING	04/08/20	TLC
32442	B	ADDED NYLON ROLLER OPT	8/5/20	TLC
32442	C	ADDED IRC/IBC NOTE	8/19/20	TLC

13 GA ROLLER SLIDE ATTACHED TO BRACKET WITH 5/16-18 BOLT & NUT IN CENTER SLOT AND 1/4-20x9/16" TRACK BOLT & 1/4-20 HEX NUT THROUGH ANY TWO ALIGNING HOLES

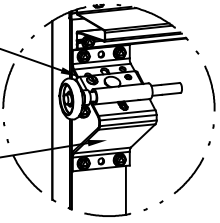

DETAIL A

12 GA COMMERCIAL 'A' FRAME TOP BRACKET ATTACHED WITH (4) 1/4-14x7/8" SELF DRILLING CRIMPTITE SCREWS

ADD (2) 1/4-14x7/8" SELF DRILLING CRIMPTITE SCREWS (INSIDE OF EACH END HINGE)

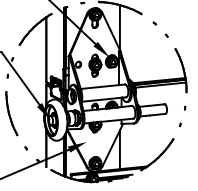

DETAIL B

2" STEEL ROLLER WITH 5-1/4" STEM OPTIONAL NYLON, 10/11-BALL BEARING ROLLER AVAILABLE

13 GA WIDE BODY END HINGE ATTACHED WITH (4) 1/4-14x7/8" SELF DRILLING CRIMPTITE SCREWS

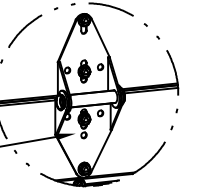

DETAIL C

14 GA WIDE BODY INTERMEDIATE HINGE ATTACHED WITH (4) 1/4-14x7/8" SELF DRILLING CRIMPTITE SCREWS

14 GA BOTTOM BRACKET ATTACHED WITH (2) 1/4-14x7/8" SELF DRILLING CRIMPTITE SCREWS AND (1) 1/4-14x5/8" SELF DRILLING TAMPER RESISTANT SCREW

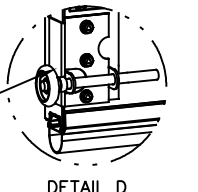

DETAIL D

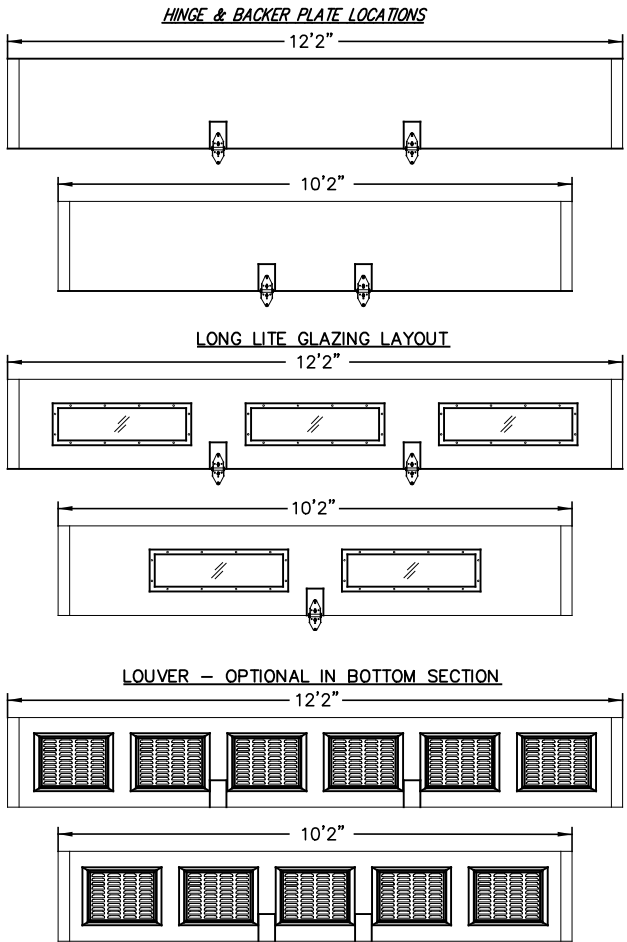

ALL U-BARS SHALL BE ATTACHED WITH (2) 1/4-14x7/8" SELF DRILLING CRIMPTITE SCREWS AT EACH HINGE LOCATION AND BETWEEN ALL END HINGES AND INTERMEDIATE HINGES. A MINIMUM OF (10) FASTENERS ARE TO BE USED.

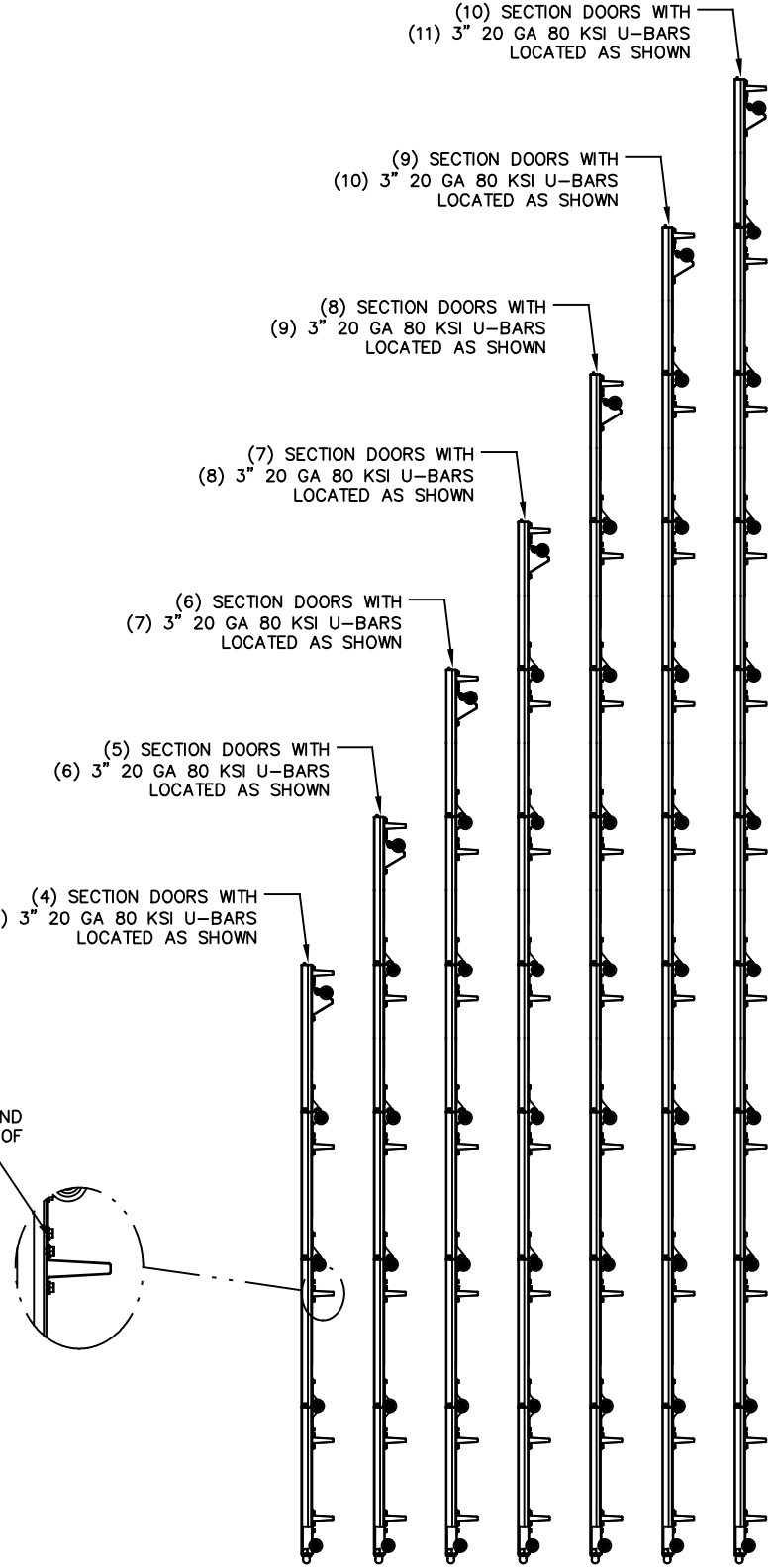

STATIC PRESSURE RATINGS	APPROVED SIZES
DESIGN PRESSURE(PSF): +19.3/-21.6	MAX WIDTH: 12'-2"
IMPACT/CYCLIC RATED: NO	MAX HEIGHT: 24'
	MAX SECTION HEIGHT: 24'

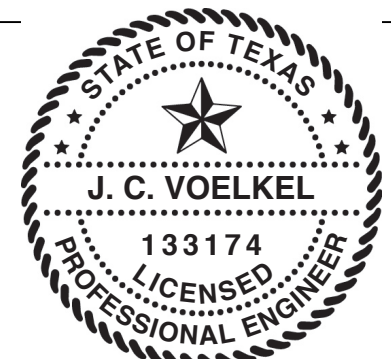

J. CHRISTIAN VOELKEL, PE  
312 N. NEW WARRINGTON RD, UNIT 1A  
PENSACOLA, FL  
FL PE 82229  
TX PE 133174

PROFESSIONAL ENGINEER'S SEAL PROVIDED ONLY FOR VERIFICATION OF WIND LOAD CONSTRUCTION DETAILS.

THE DOORS ARE DESIGNED AND MANUFACTURED TO COMPLY WITH THE 2018 IRC AND THE 2018 IBC.

REF DWG		USED ON	TOLERANCES UNLESS OTHERWISE SPECIFIED		FINISH	THE GENUINE. THE ORIGINAL.		NAME		DATE	DRAWING TITLE	
			HOLE DIAMETER	WHOLE NUMBERS: ± .25	N/A	OVERHEAD DOOR		T. CLARK		02/04/20	SERIES 5745/5765/7565	
			UNDER .251 +.004/-0.003	.X ± .1	UNIT OF MEASURE	LEWISVILLE, TEXAS		CHECKED BY:			7655/515/525	
			.251 TO .500 +.006/-0.003	.XX ± .03		MATERIAL:	NONE		APPROVED BY:			DRAWING NUMBER
			OVER .500 +.008/-0.003	.XXX ± .010								D-411621
			FRACTIONS	ANGLES: ± .5°							SCALE: N.T.S. SHEET 2 OF 2	
			± 1/16									

AND PROPRIETARY PROPERTY OF OVERHEAD DOOR CORPORATION AND ITS AFFILIATED COMPANIES. THIS DRAWING DISCLOSED TO ANYONE WITHOUT THE PRIOR WRITTEN CONSENT OF OVERHEAD DOOR CORPORATION. NO DISCLOSURE OF AUTHORIZATION TO USE IT FOR ANY PURPOSE WITHOUT THE SPECIFIC WRITTEN CONSENT OF OVERHEAD DOOR CORPORATION.