

NOTES: (UNLESS OTHERWISE SPECIFIED)

1. RATED DESIGN LOAD +46/-52 PSF.
2. SECTION HEIGHTS MAY VARY TO CREATE VARIOUS DOOR HEIGHTS, 24" MAXIMUM SECTION HEIGHT.
3. MINIMUM 1" OVERLAP ON BOTH JAMBS REQUIRED TO MEET NEGATIVE DESIGN PRESSURES.
4. TESTED IN ACCORDANCE WITH DADE COUNTY PROTOCOLS TAS 201-94, TAS 202-94, & TAS 203-94.
5. DOOR SKIN MUST BE 50,000 PSI MIN. YIELD STRENGTH.
6. JAMB LOAD CALCULATIONS:  
 $(1/2 \text{ DOOR WIDTH}) \times (1 \text{ FT OF HEIGHT}) \times (\text{DESIGN PRESSURE})$   
 $(6.067 \times 1 \text{ FOOT}) \times (46.00 \text{ AND } -52.00) \times (279.08 / -315.48) \text{ LB}$
7. JAMB FASTENER REQUIREMENTS:  
 $F_x = (1/2 \text{ DOOR WIDTH}) \times (1 \text{ FT OF HEIGHT}) \times (\text{DESIGN PRESSURE})$   
 $F_y = 280 \text{ LBS.}$
8. DOOR SKIN MATERIAL SHALL BE GALVANIZED ACCORDING TO ASTM A-525 TO G40 MIN, WITH BAKED-ON PRIMER, AND BAKED-ON POLYESTER PAINT TOP COAT.
9. FOR ANCHORING INTO WOOD, USE ONE 5/16" LAG SCREW PER TRACK BRACKET WITH 1-1/2" EMBEDMENT INTO SOUTHERN PINE (G=0.55) OR BETTER.
10. WELD SLOT ON ANGLE 3/32" X 1" LONG ON 12" CENTERS. "IF WELDING MOUNTING OPTION IS CHOSEN."
11. LIFT UP MECHANISM-MANUAL, CHAIN LIFT, OR OPERATOR IS NOT PART OF THIS APPROVAL.
12. STANDARD LIFT, HIGH LIFT, VERTICAL LIFT, AND LOW HEADROOM TRACK IS AVAILABLE. FOR LOW HEADROOM LIFT CONDITIONS TOP BRACKET SHALL BE 13 GA LHR 7/4 TOP BRACKET WITH A MIN OF (3) 1/4 - 14 X 7/8" SELF DRILLING CRIMP TITE SCREWS IN LIEU OF THE BRACKET SHOWN ON DRAWING. U-BAR ON TOP SECTION SHALL BE INSTALLED ON TOP OF LHR TOP BRACKETS.
13. ATTACH STRUTS WITH (2) 1/4-14x7/8" SELF DRILLING CRIMP TITE SCREWS AT ALL HINGE LOCATIONS AND (2) BETWEEN EACH INTERMEDIATE HINGE. TYP. STRUT LOCATED AT TOP AND/ OR AT BOTTOM OF SECTION.
14. KEY LOCK, OR SIDE LOCK REQUIRED.
15. EXHAUST PORTS- OPTIONAL UP TO 3 PER BOTTOM SECTION.
16. IMPACT RESISTANT GLAZING OPTION- IMPACT RESISTANT GLAZING SYSTEM MAY AND BE INSTALLED IN TOP OR INTERMEDIATE SECTIONS. GLAZING SHALL BE 1/4" POLYCARBONATE. 14" X 46" MAXIMUM SIZE, FASTENED WITH # 8 X 1" SMS. 5X MAX ALONG THE HORIZONTAL AND 3X MAX ALONG THE VERTICAL. SEE DETAIL F-F ON SHEET 2 FOR ASSEMBLY DETAILS.
17. THE DESIGN OF THE SUPPORTING STRUCTURAL ELEMENTS SHALL BE THE RESPONSIBILITY OF THE PROFESSIONAL OF RECORD FOR THE BUILDING OR STRUCTURE AND IN ACCORDANCE WITH CURRENT BUILDING CODES FOR THE LOADS LISTED ON THIS DRAWING.
18. LOUVER OPTION - LOUVERS MAY BE INSTALLED IN DOOR IF THE AREA OF EACH LOUVER DOES NOT EXCEED 60 IN. DOOR VENTS LARGER THAN 60 IN MUST BE TESTED FOR IMPACT.
19. A 4-1/2" X 6" X 22 GA BACKER PLATE IS TO BE LOCATED AT EVERY INTERMEDIATE AND OUTER END HINGE LOCATIONS.

THE DOORS ARE DESIGNED AND MANUFACTURED TO COMPLY WITH THE 2018 IRC AND THE 2018 IBC.

REVISIONS				
ER	REV	DESCRIPTION	DATE	APVL
ER	P00	NEW DRAWING	8/28/18	ESC
32442	A	ADDED IRC/IBC NOTE	8/28/20	TLC

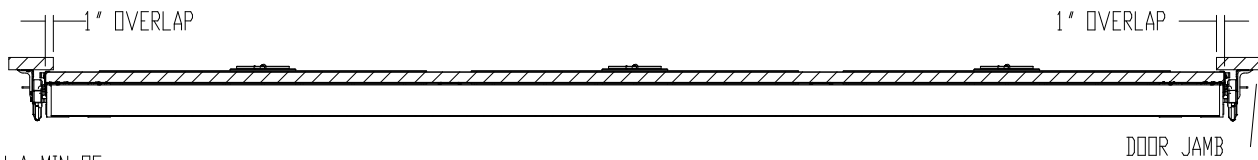

SECTION B-B  
SCALE 1 : 12

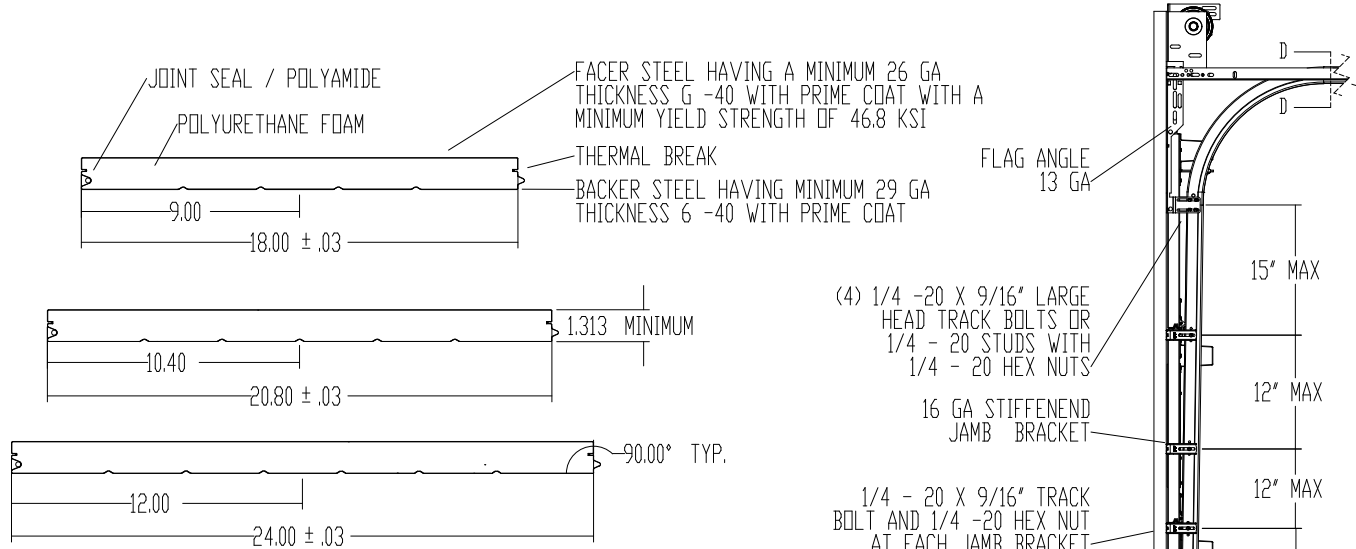

SECTION A-A  
SCALE 1 : 4

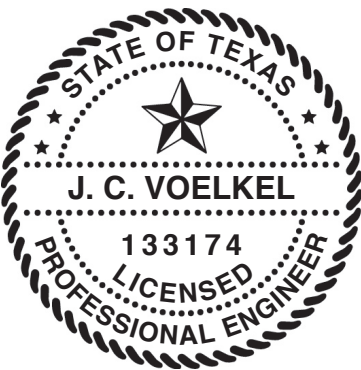

J. CHRISTIAN VOELKEL, PE  
 312 N. NEW WARRINGTON ROAD, UNIT 1A  
 PENSACOLA, FL  
 FL PE 82229 TX PE 133174  
 PROFESSIONAL ENGINEER'S SEAL PROVIDED ONLY FOR  
 VERIFICATION OF WINDLOAD CONSTRUCTION DETAILS.

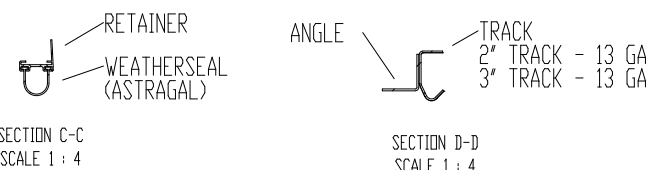

SECTION C-C  
SCALE 1 : 4

SECTION D-D  
SCALE 1 : 4

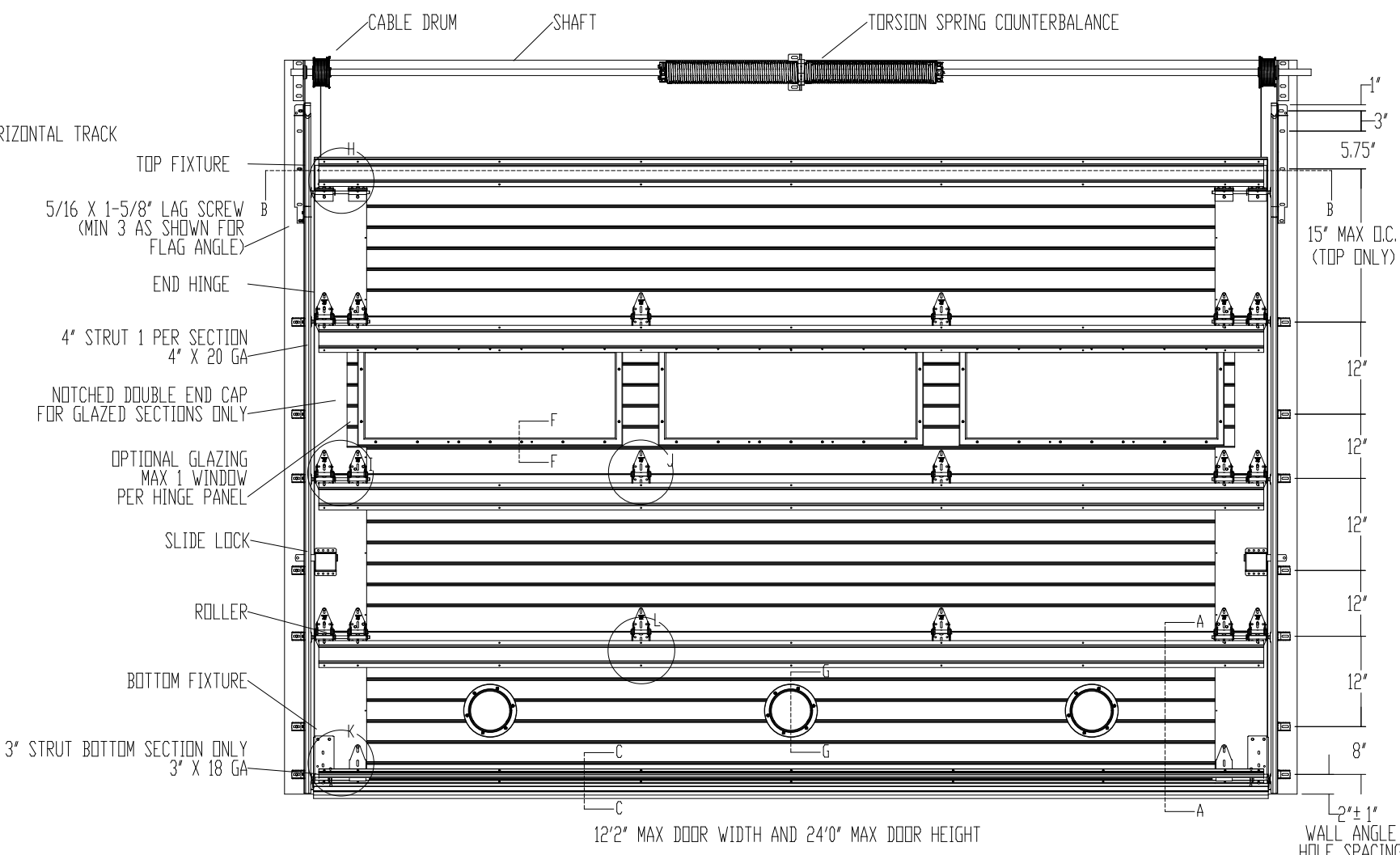

12'2" MAX DOOR WIDTH AND 24'0" MAX DOOR HEIGHT

2"±1" WALL ANGLE HOLE SPACING

<p>THIRD ANGLE PROJECTION</p>	<p>UNLESS OTHERWISE SPECIFIED</p> <p>INTERPRET DIMS &amp; TOLS PER ASME Y14.5M</p> <p>ALL DIMS ARE IN INCHES</p> <p>DO NOT SCALE</p> <p>DIMS CIRCLED WITH SYMBOL 'O' ARE CRITICAL TO QUALITY DESIGN FEATURES &amp; MUST MEET APPLICABLE IN-PROCESS INSPECTION STANDARDS.</p>	<p>TOLERANCES:</p> <p>.X = ±.1</p> <p>.XX = ±.03</p> <p>.XXX = ±.010</p> <p>ANGULAR = ±.5°</p> <p>HOLES:</p> <p>&lt; 0.251 = +.004/-0.03</p> <p>0.251-0.500 = +.006/-0.03</p> <p>&gt; 0.500 = +.008/-0.03</p> <p>ALL GEOMETRY GOVERNED BY 3D CAD DATABASE: 8300_WL_FLUSH_COMPLETE_DOOR</p>	<p>APPROVALS DATE</p> <p>DRAWN E. CONRAD 8/28/18</p> <p>CHECKED D. KORNISH -</p> <p>APPROVED -</p> <p>MATERIAL -</p> <p>FINISH -</p>	<p>DESCRIPTION</p> <p>WINDLOAD MODELS 4600/4650/5745/5765/7565/515/525/850, +46/-52PSF DADE COUNTY, 12'2" MAX WIDTH</p>
			<p>LEWISVILLE, TEXAS</p>	<p>SIZE DWG NO. D-411529</p> <p>REV A</p>
<p>OVERHEAD DOOR CORP                  2501 S. STATE HWY 121 SUITE 200                  LEWISVILLE, TEXAS 75067                  469-549-7100</p>		<p>SCALE 1:12 UDM = EA SHEET 1 OF 4</p>		

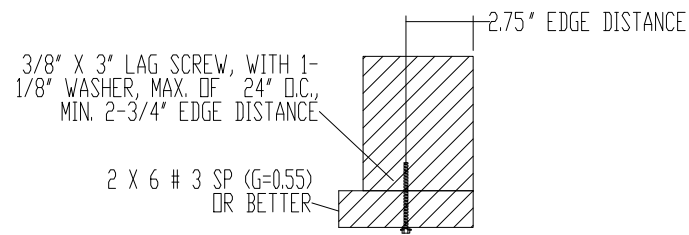

WOOD MOUNTED TO # 3 SOUTHERN PINE SUBSTRATE

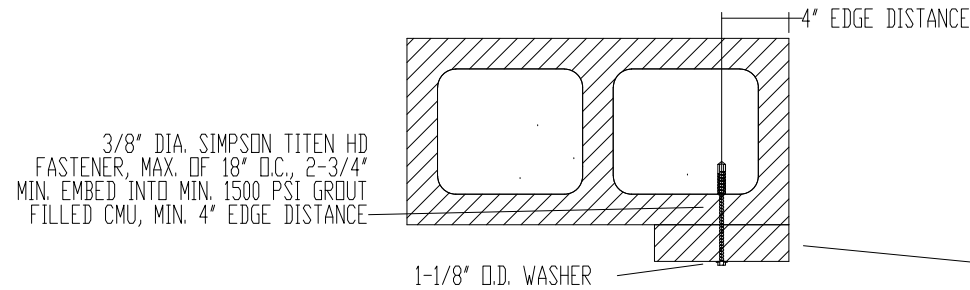

WOOD MOUNTED TO GROUT FILLED MASONRY BLOCK DETAIL

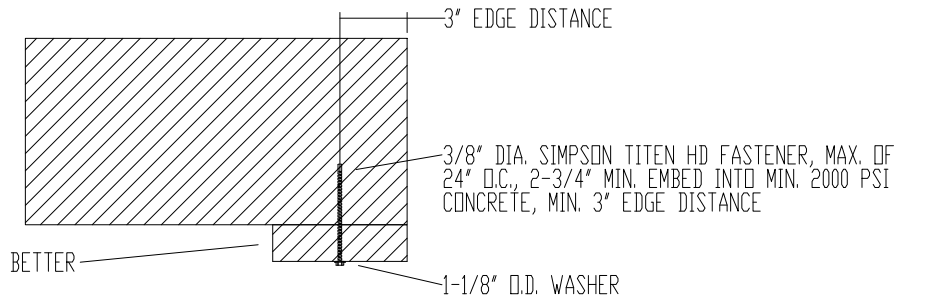

WOOD MOUNTED TO 2000 PSI CONCRETE DETAIL

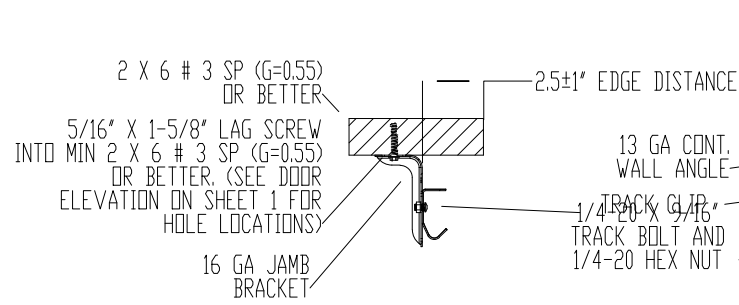

MOUNTING TO WOOD JAMB DETAIL

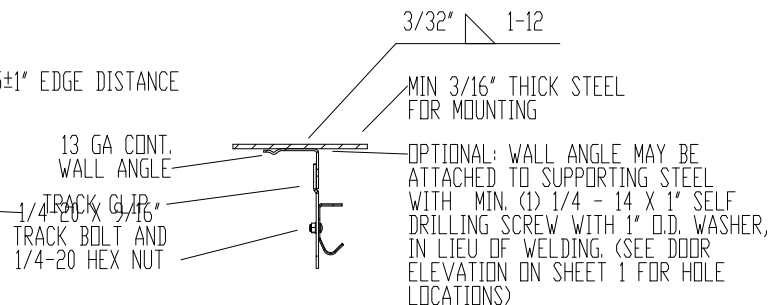

MOUNTING TO STEEL JAMB DETAIL

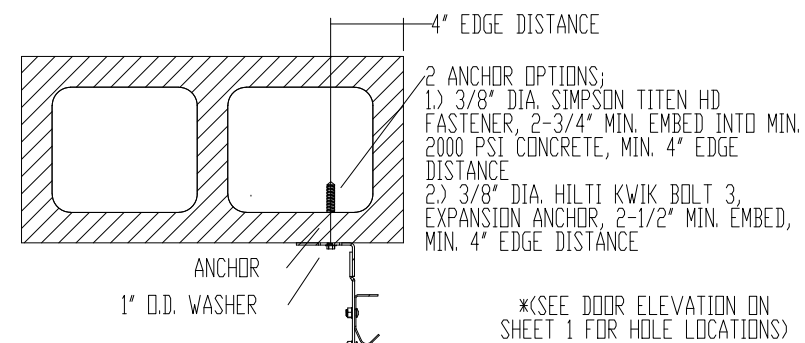

MOUNTING TO GROUT FILLED MASONRY BLOCK DETAIL

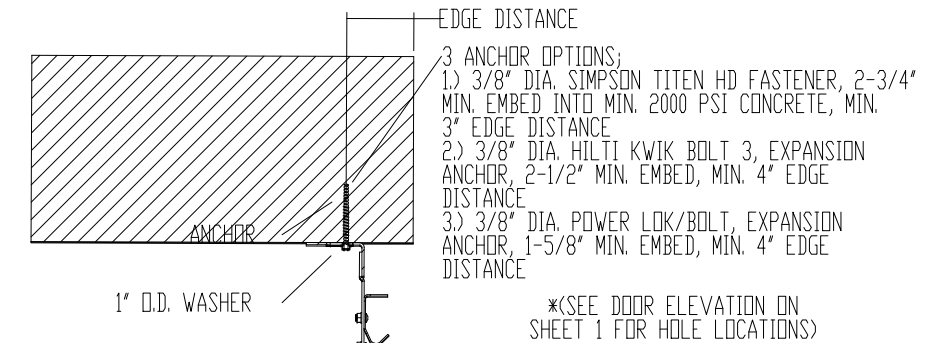

MOUNTING TO 2000 PSI CONCRETE DETAIL

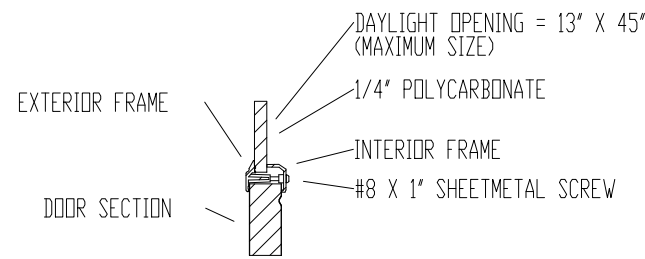

WINDOW DETAIL

SECTION F-F SCALE 1:4

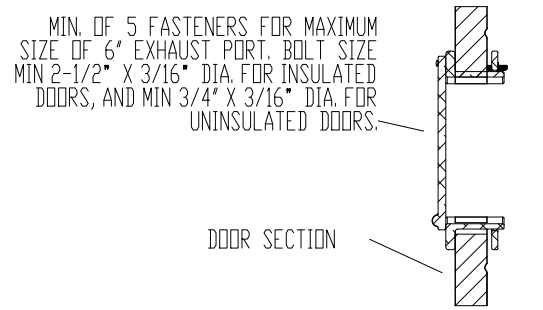

EXHAUST PORT DETAIL

SECTION G-G SCALE 1:4

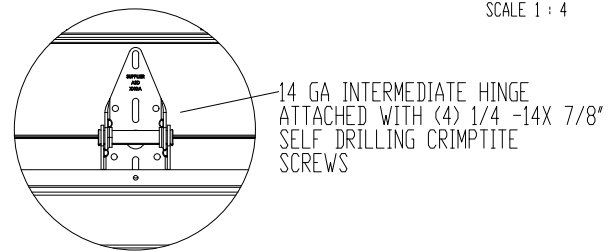

DETAIL J SCALE 1:4

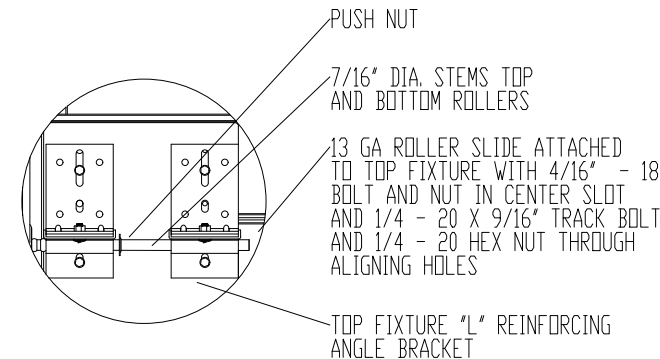

DETAIL H SCALE 1:4

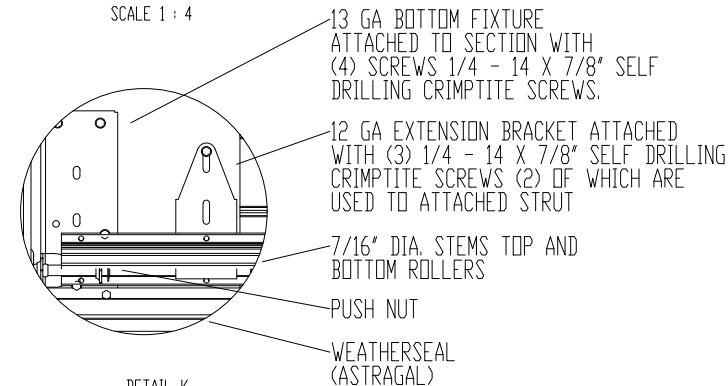

DETAIL K SCALE 1:4

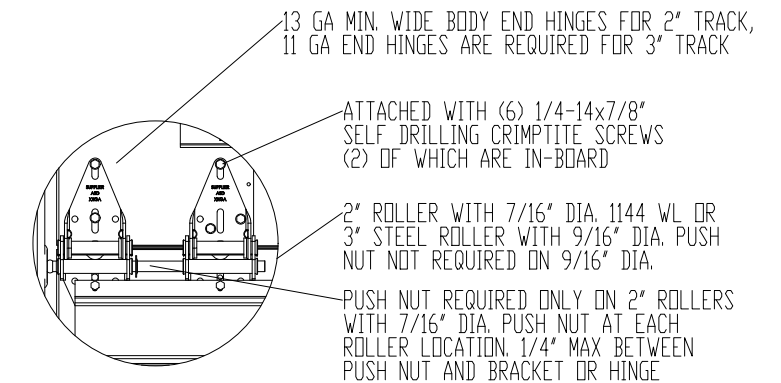

DETAIL I SCALE 1:4

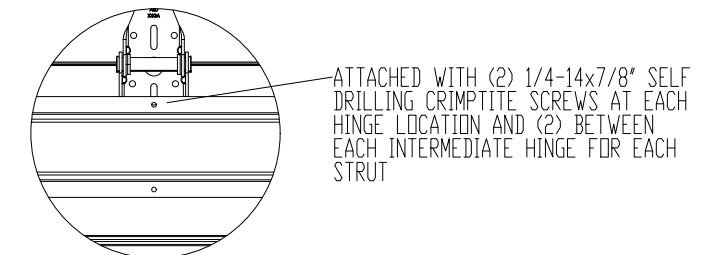

DETAIL L SCALE 1:4

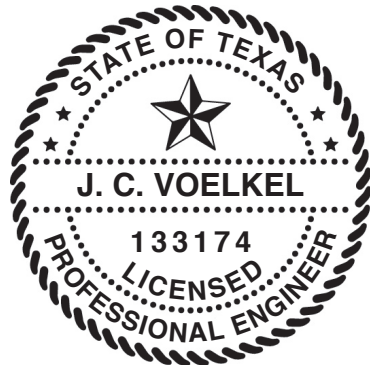

J. CHRISTIAN VOELKEL, PE  
312 N. NEW WARRINGTON ROAD, UNIT 1A  
PENSACOLA, FL  
FL PE 82229 TX PE 133174

PROFESSIONAL ENGINEER'S SEAL PROVIDED ONLY FOR VERIFICATION OF WINDLOAD CONSTRUCTION DETAILS.

<p>THIRD ANGLE PROJECTION</p>	<p>UNLESS OTHERWISE SPECIFIED</p> <p>INTERPRET DIMS &amp; TOLS PER ASME Y14.5M ALL DIMS ARE IN INCHES DO NOT SCALE DIMS CIRCLED WITH SYMBOL 'O' ARE CRITICAL TO QUALITY DESIGN FEATURES &amp; MUST MEET APPLICABLE IN-PROCESS INSPECTION STANDARDS.</p>	<p>TOLERANCES:</p> <p>.X = ±.1 .XX = ±.03 .XXX = ±.010 ANGULAR = ±.5°</p> <p>HOLE:</p> <p>&lt; Ø.251 = +.004/-0.003 Ø.251-Ø.500 = +.006/-0.003 &gt; Ø.500 = +.008/-0.003</p> <p>ALL GEOMETRY GOVERNED BY 3D CAD DATABASE: 8300 WL FLUSH COMPLETE DOOR</p>	<p>APPROVALS DATE</p> <p>DRAWN E. CONRAD 8/28/18</p>	<p>LEWISVILLE, TEXAS</p>
			<p>CHECKED D. KORNISH -</p> <p>APPROVED - -</p> <p>MATERIAL - -</p> <p>FINISH - -</p>	
<p>OVERHEAD DOOR CORP 2501 S. STATE HWY 121 SUITE 200 LEWISVILLE, TEXAS 75067 469-549-7100</p>	<p>SCALE 1:12 UOM = EA SHEET 2 OF 4</p>			

NOTES: (UNLESS OTHERWISE SPECIFIED)

1. ONE 4" STRUT PER SECTION, AND ONE 3" STRUT PER BOTTOM SECTION, ATTACHED WITH 1/4"-14X7/8" SELF DRILLING CRIMPTITE SCREWS.

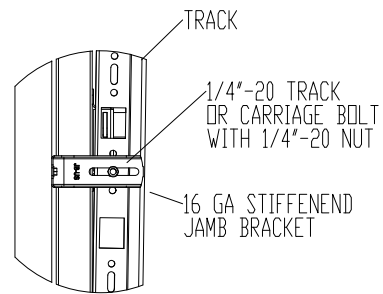

TYPICAL TRACK AND JAMB FASTENERS DETAIL

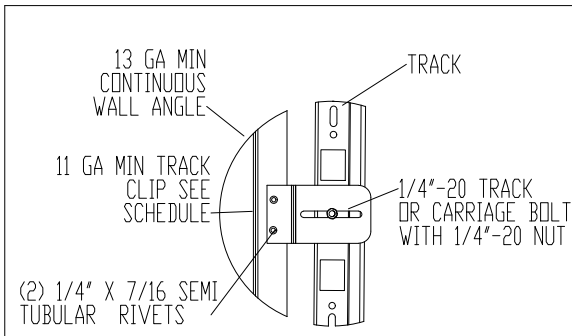

TYPICAL TRACK CLIP RIVETING DETAIL

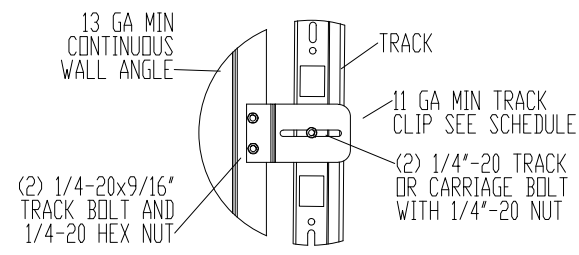

TYPICAL TRACK CLIP BOLTING DETAIL  
OPTIONAL WALL ANGLE TRACK

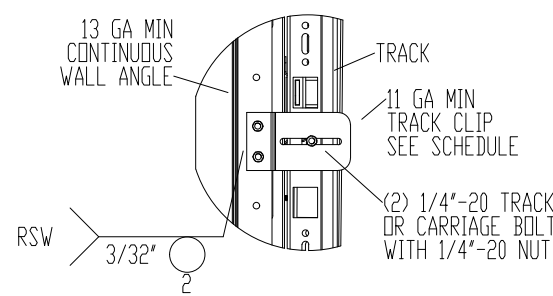

TYPICAL TRACK CLIP WELDING DETAIL

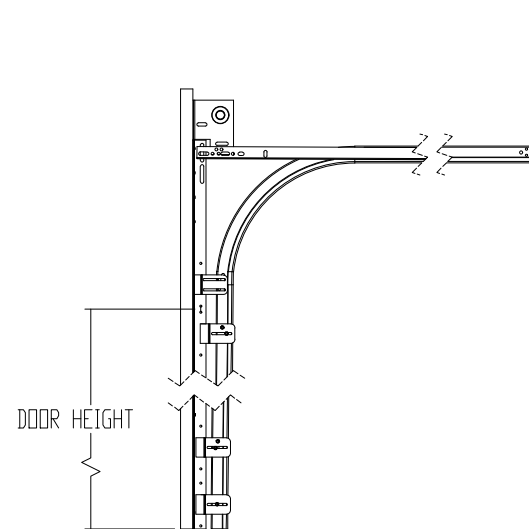

STANDARD LIFT TRACK DETAIL

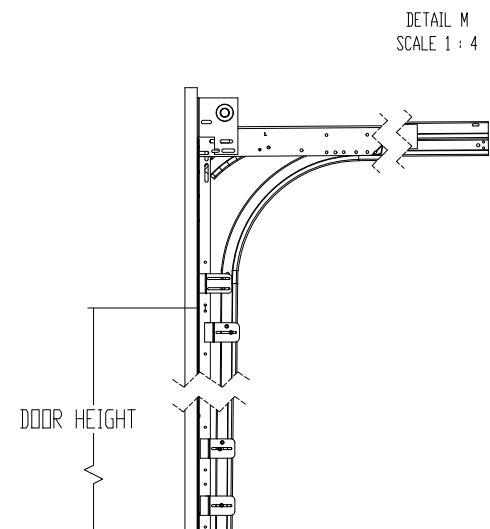

LOW HEADROOM TRACK DETAIL

TRACK DETAIL SCALE 1:12

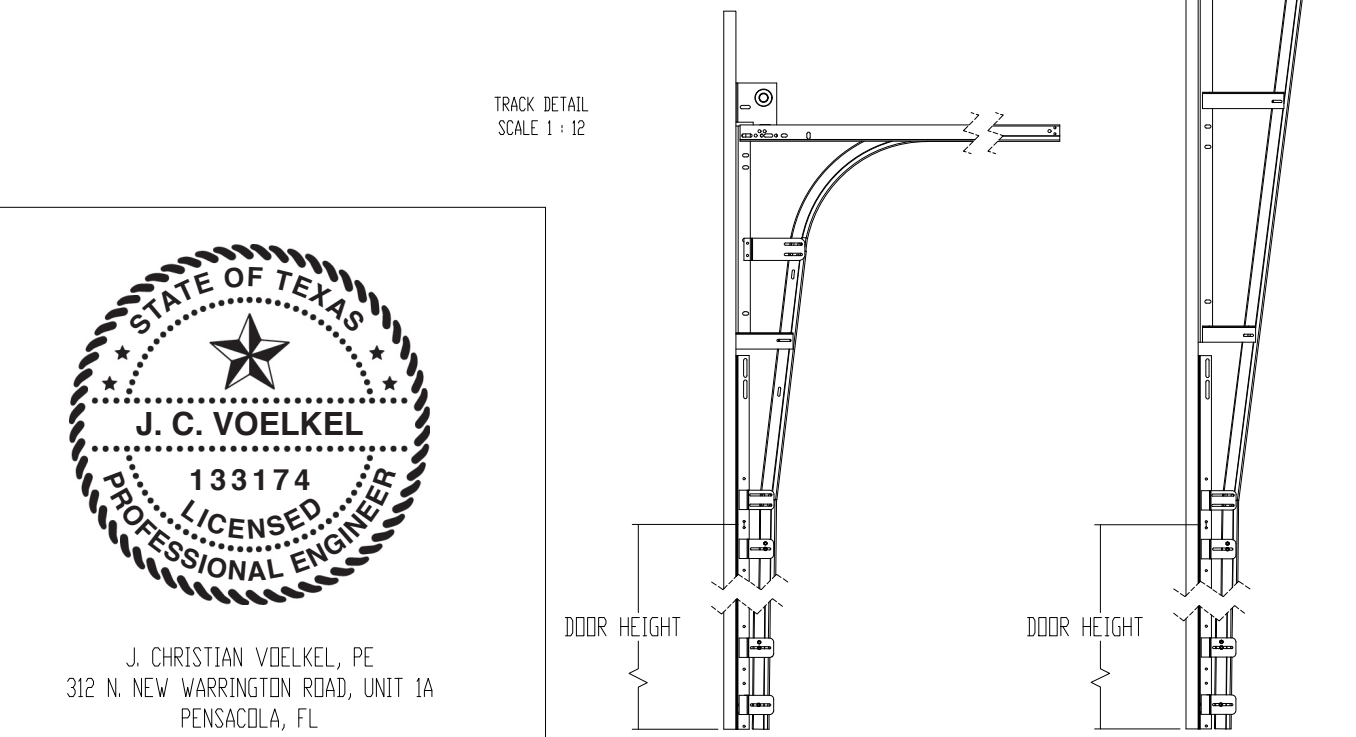

HIGH LIFT TRACK DETAIL

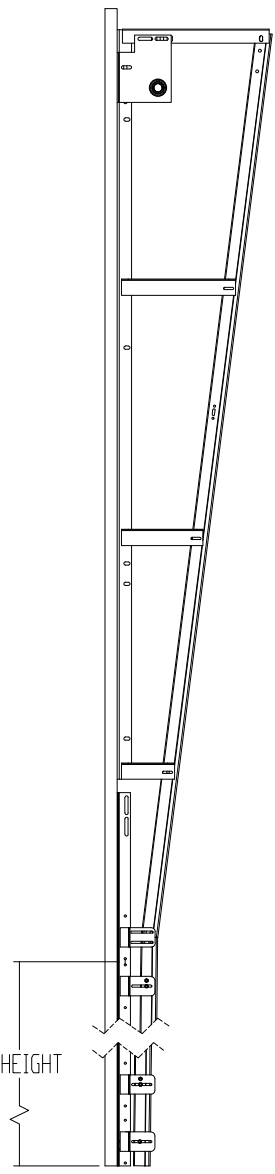

VERTICAL LIFT TRACK DETAIL

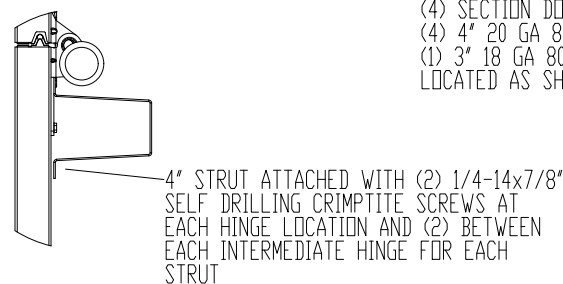

DETAIL N SCALE 1:4

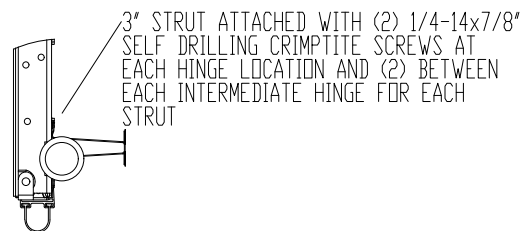

DETAIL D SCALE 1:4

(7) SECTION DOORS WITH  
(7) 4" 20 GA 80 KSI U- BARS  
(1) 3" 18 GA 80 KSI U- BARS  
LOCATED AS SHOWN

(6) SECTION DOORS WITH  
(6) 4" 20 GA 80 KSI U- BARS  
(1) 3" 18 GA 80 KSI U- BARS  
LOCATED AS SHOWN

(5) SECTION DOORS WITH  
(5) 4" 20 GA 80 KSI U- BARS  
(1) 3" 18 GA 80 KSI U- BARS  
LOCATED AS SHOWN

(4) SECTION DOORS WITH  
(4) 4" 20 GA 80 KSI U- BARS  
(1) 3" 18 GA 80 KSI U- BARS  
LOCATED AS SHOWN

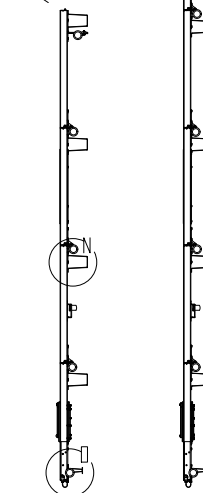

STRUT LOCATIONS SCALE 1:20

(9) SECTION DOORS WITH  
(9) 4" 20 GA 80 KSI U- BARS  
(1) 3" 18 GA 80 KSI U- BARS  
LOCATED AS SHOWN

(8) SECTION DOORS WITH  
(8) 4" 20 GA 80 KSI U- BARS  
(1) 3" 18 GA 80 KSI U- BARS  
LOCATED AS SHOWN

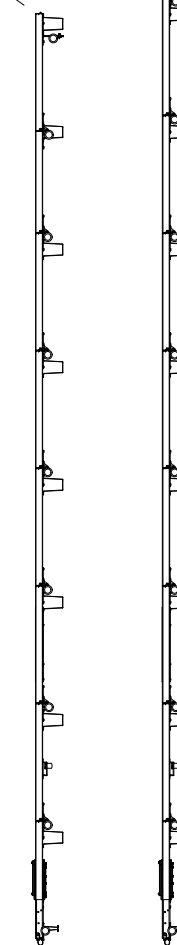

(11) SECTION DOORS WITH  
(11) 4" 20 GA 80 KSI U- BARS  
(1) 3" 18 GA 80 KSI U- BARS  
LOCATED AS SHOWN

(10) SECTION DOORS WITH  
(10) 4" 20 GA 80 KSI U- BARS  
(1) 3" 18 GA 80 KSI U- BARS  
LOCATED AS SHOWN

(12) SECTION DOORS WITH  
(12) 4" 20 GA 80 KSI U- BARS  
(1) 3" 18 GA 80 KSI U- BARS  
LOCATED AS SHOWN

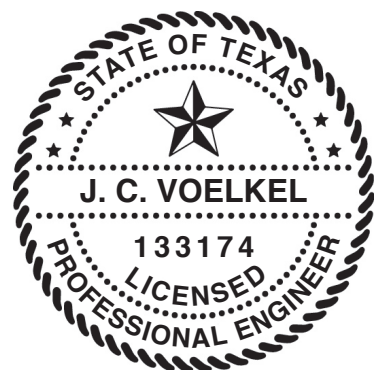
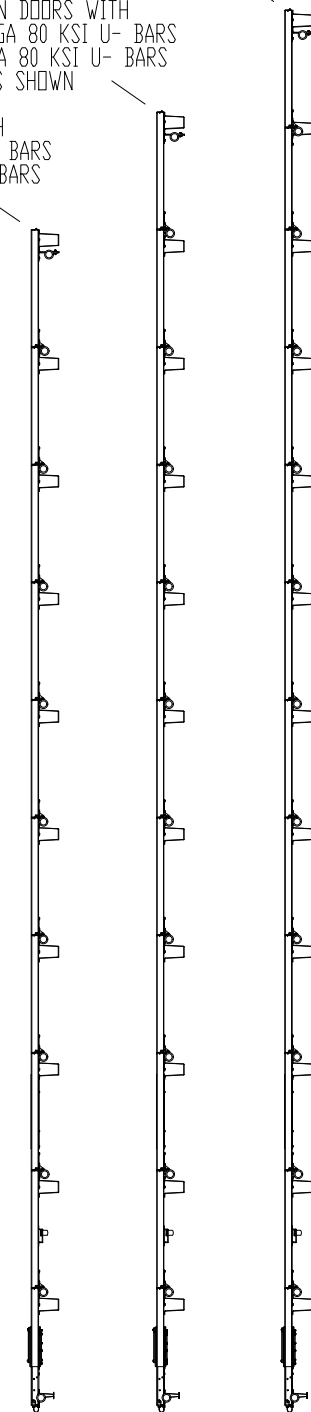

J. CHRISTIAN VOELKEL, PE  
312 N. NEW WARRINGTON ROAD, UNIT 1A  
PENSACOLA, FL  
FL PE 82229 TX PE 133174  
PROFESSIONAL ENGINEER'S SEAL PROVIDED ONLY FOR  
VERIFICATION OF WINDLOAD CONSTRUCTION DETAILS.

THIRD ANGLE PROJECTION		UNLESS OTHERWISE SPECIFIED		APPROVALS DATE		LEWISVILLE, TEXAS	
	INTERPRET DIMS & TOLS PER ASME Y14.5M ALL DIMS ARE IN INCHES DO NOT SCALE DIMS CIRCLED WITH SYMBOL 'D' ARE CRITICAL TO QUALITY DESIGN FEATURES & MUST MEET APPLICABLE IN-PROCESS INSPECTION STANDARDS.	TOLERANCES: .X = ±.1 .XX = ±.03 .XXX = ±.010 ANGULAR = ±.5°		DRAWN E. CONRAD 8/28/18 CHECKED D. KORNISH - APPROVED - - MATERIAL -	DESCRIPTION WINDLOAD MODELS 4600/4650/5745/5765/ 7565/515/525/850, +46/-52PSF DADE COUNTY, 12'2" MAX WIDTH		SIZE DWG NO. REV D D-411529 A
		HOLES: < Ø.251 = +.004/-.003 Ø.251-Ø.500 = +.006/-.003 > Ø.500 = +.008/-.003		FINISH -	ALL GEOMETRY GOVERNED BY 3D CAD DATABASE: 8300 WL FLUSH COMPLETE DOOR		

NOTES: (UNLESS OTHERWISE SPECIFIED)  
 1. FOR DIMENSIONS AND NOTE REFERENCES, REFER TO INDIVIDUAL DRAWINGS.

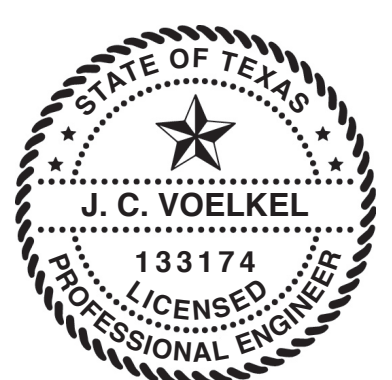
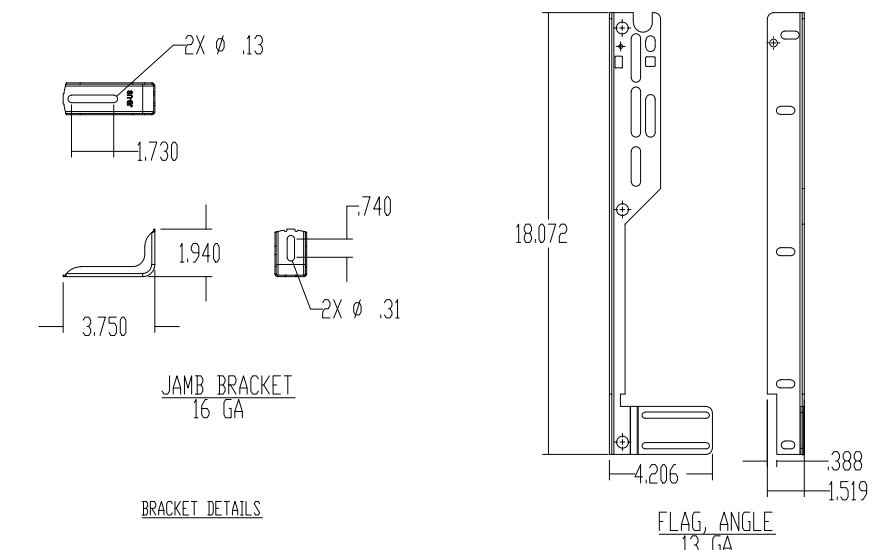
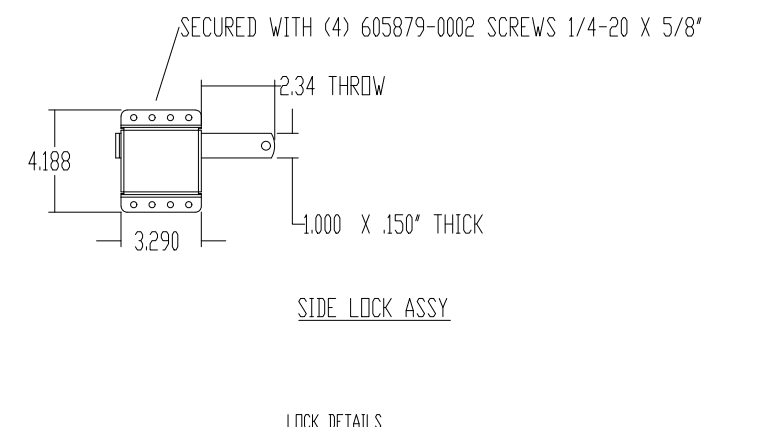
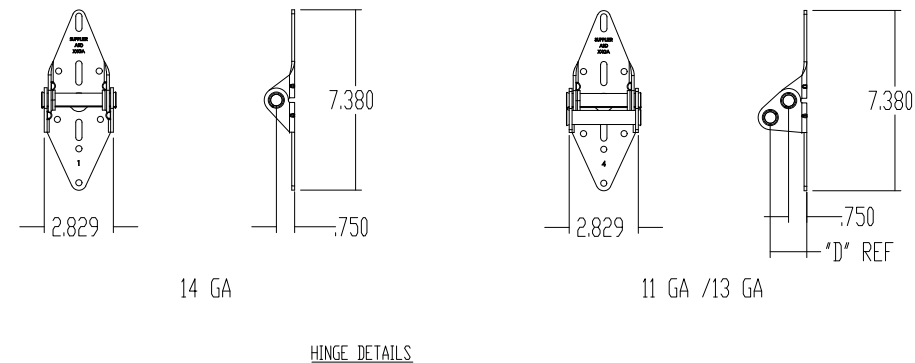
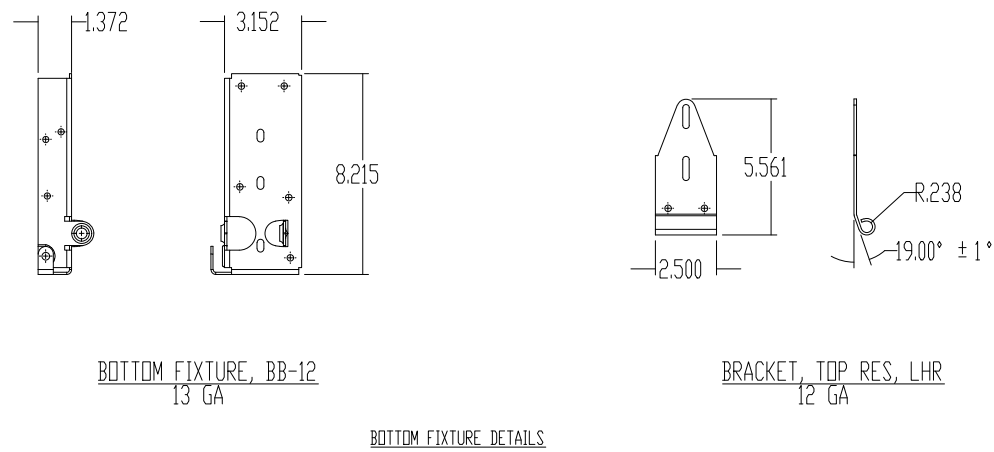
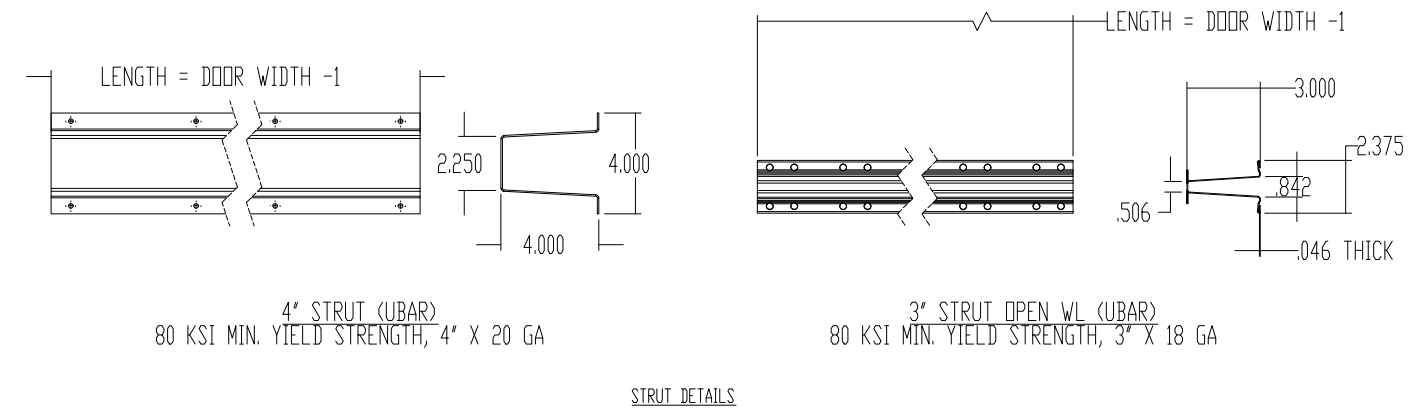
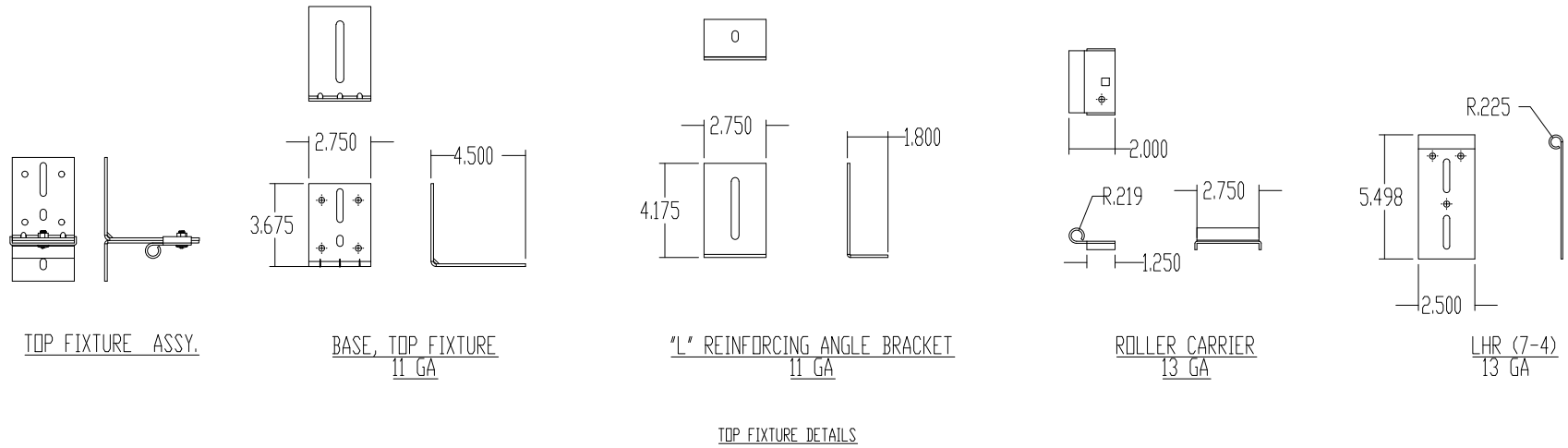

J. CHRISTIAN VOELKEL, PE  
 312 N. NEW WARRINGTON ROAD, UNIT 1A  
 PENSACOLA, FL  
 FL PE 82229 TX PE 133174  
 PROFESSIONAL ENGINEER'S SEAL PROVIDED ONLY FOR  
 VERIFICATION OF WINDLOAD CONSTRUCTION DETAILS.

THIRD ANGLE PROJECTION 	UNLESS OTHERWISE SPECIFIED INTERPRET DIMS & TOLS PER ASME Y14.5M ALL DIMS ARE IN INCHES DO NOT SCALE DIMS CIRCLED WITH SYMBOL 'Ø' ARE CRITICAL TO QUALITY DESIGN FEATURES & MUST MEET APPLICABLE IN-PROCESS INSPECTION STANDARDS.	TOLERANCES: .X = ±.1 .XX = ±.03 .XXX = ±.010 ANGULAR = ±.5° HOLES: < Ø.251 = +.004/-0.003 Ø.251-Ø.500 = +.006/-0.003 > Ø.500 = +.008/-0.003 ALL GEOMETRY GOVERNED BY 3D CAD DATABASE: 8300 WL FLUSH COMPLETE DOOR	APPROVALS      DATE DRAWN      E. CONRAD      8/28/18 CHECKED      D. KORNISH      - APPROVED      -      - MATERIAL      -      -	LEWISVILLE, TEXAS
			FINISH      -	DESCRIPTION WINDLOAD MODELS 4600/4650/5745/5765/ 7565/515/525/850, +46/-52PSF DADE COUNTY, 12'2" MAX WIDTH
		SCALE 1:12      UOM =      SHEET 4 OF 4		