

REVISIONS			
REV	DESCRIPTION	DATE	APPROVAL
	DRAWING RELEASE	5-30-07	DM
A	NOTE REVISIONS	6-17-09	CS
B	16 GA. STEEL JAMB/1.5X1.5X.072MIN BB	7-7-17	CS
C	Note: Alternate Concrete/Masonry Fasteners	9-25-17	CS
D	Add wood jamb detail & fasteners	03/03/20	CS
E	ADD DEWALT ULTRACON AS ALTERNATE FASTENER	05/07/20	CS
F	ADD IBC/IRC 2018 COMPLIANCE TO NOTES	11/11/21	BA

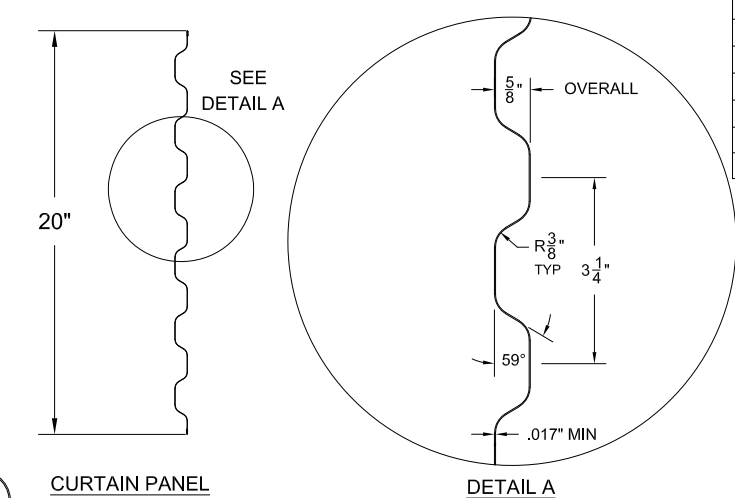
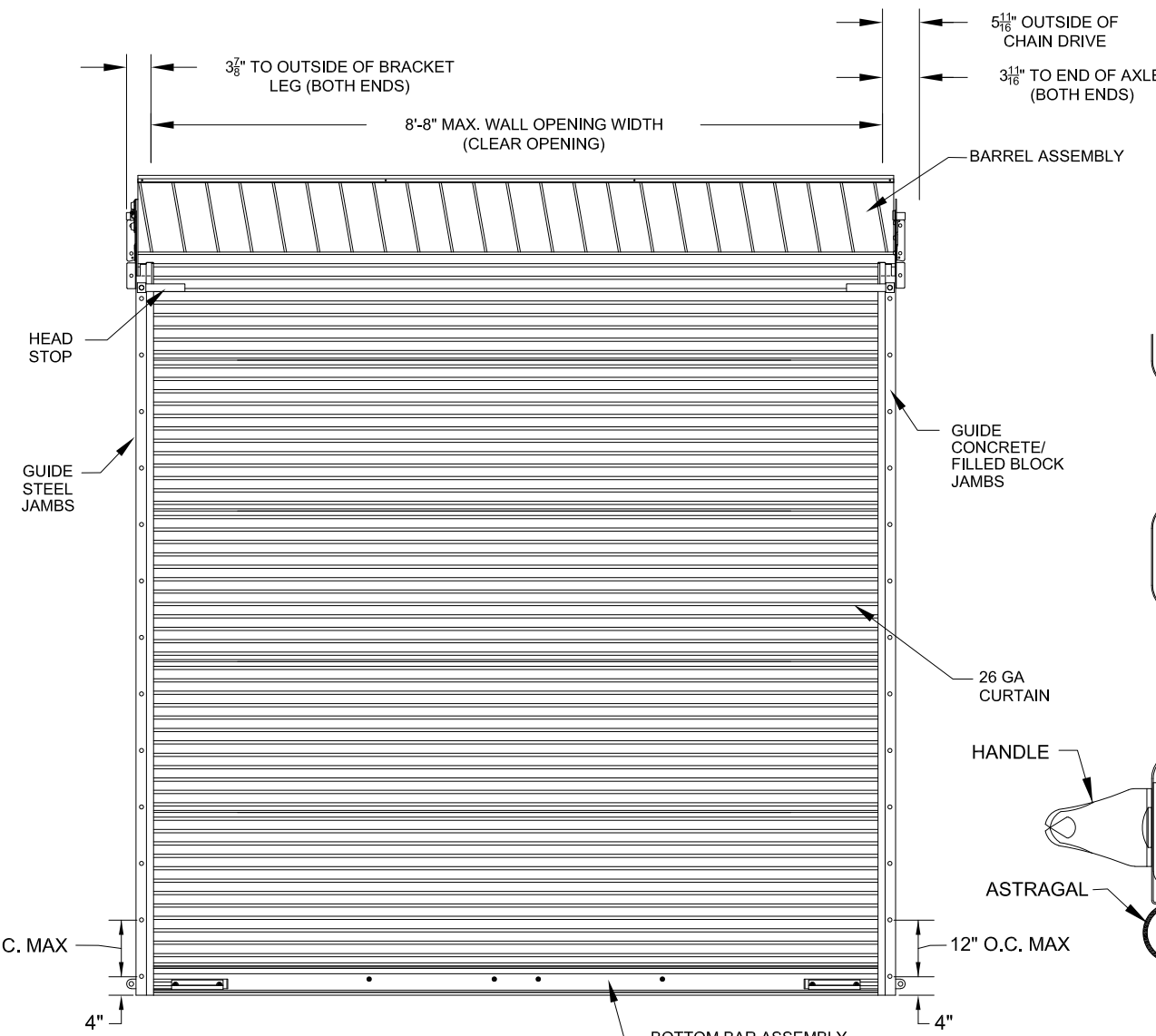
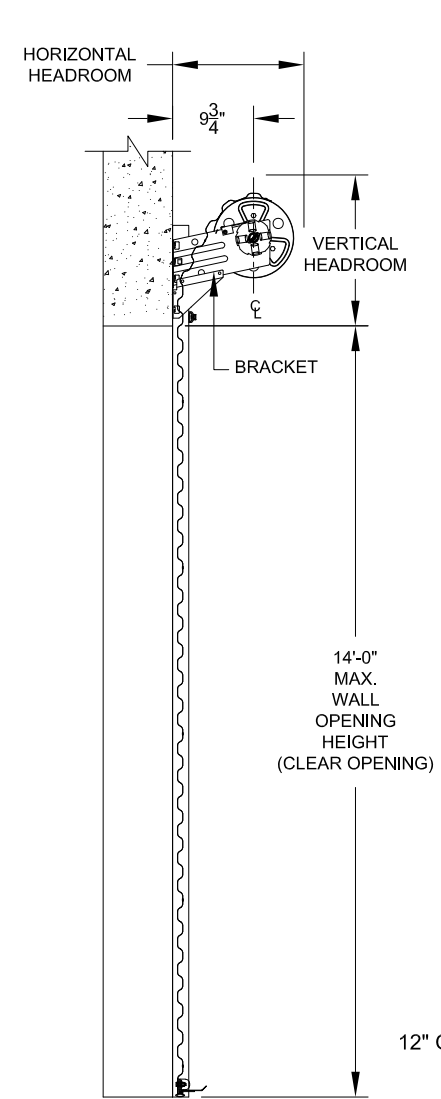

CURTAIN PANEL  
 ASTM A653 GR80 - ZINC COATED STEEL. PRE-PAINTED WITH FULL COAT OF PRIMER AND BAKED SILICONIZED POLYESTER FINISH COAT

26 GA CURTAIN DETAIL  
 24 GA. (0.022") GALV. STEEL BOTTOM BAR  
 ASTM A653 W/MIN. FY = 33 KSI

DOUBLE 1/4" Ø THRU BOLT WITH LOCKING NUT LOCATED AT EACH END AND MIDDLE OF ANGLE. INTERMEDIATE SINGLE BOLT LOCATED 24" MAX O.C.

1-1/2" X 1-1/2" X 0.072" MIN GALV. STEEL ANGLE  
 ASTM A653 W/MIN. FY = 33 KSI  
 CONTINUOUS FULL CURTAIN WIDTH

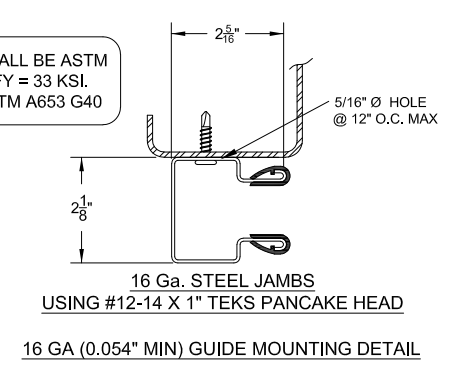
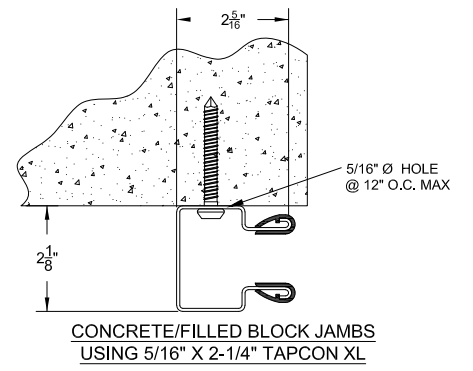

ALL COMPONENTS SHALL BE ASTM A653 STEEL W/MIN FY = 33 KSI. GALVIANIZED PER ASTM A653 G40

John E. Scates, P.E.  
 2560 King Arthur Blvd, Ste 124-54  
 Lewisville, TX 75056  
 FL PE 51737\_TX PE 56308/F2203

Professional Engineer's seal provided only for verification of windload construction details.  
 Printed copies of this document are not considered signed and sealed and the signature must be verified on any electronic copies.

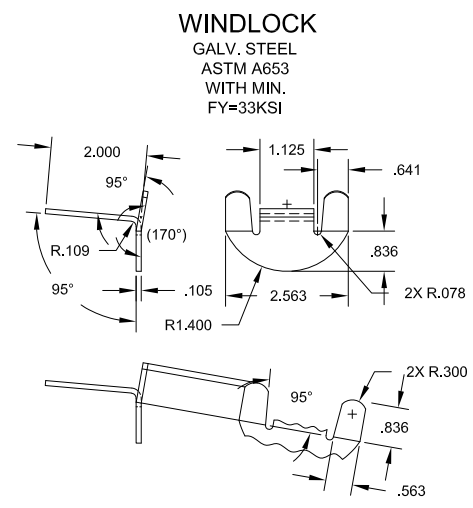

OPENING WIDTH	DESIGN LOAD POSITIVE (psf)	DESIGN LOAD NEGATIVE (psf)
6'-0"	34.7	38.5
7'-0"	30.0	33.2
8'-0"	26.2	29.1
8'-8"	24.4	27.0

OPENING HEIGHT	VERTICAL HEADROOM	HORIZONTAL HEADROOM
THRU 8'-0"	18"	17-1/2"
OVER 8'-0" THRU 10'-0"	18-1/2"	17-3/4"
OVER 10'-0" THRU 12'-0"	18-3/4"	18"
OVER 12'-0" THRU 14'-0"	19"	18-1/2"

THESE CONFIDENTIAL DOCUMENTS SUBMITTED BY JANUS CONTAIN INFORMATION OF A PROPRIETARY NATURE AND MAY NOT BE REPRODUCED OR USED TO MANUFACTURE ANYTHING IN PART OR IN WHOLE FOR ANY PURPOSE OTHER THAN THAT WHICH IS NECESSARY FOR PREPARATION OF BIDS OF ENGINEERING WITHOUT THE EXPRESS PERMISSION OF JANUS WHICH MAY RECALL DOCUMENTS AT ANY TIME.

UNLESS OTHERWISE SPECIFIED DIMENSIONS ARE IN INCHES AND TOLERANCES ARE:

DECIMAL	FRACTIONS	ANGLES	HOLE DIAMETERS
.XX ±.03	± 1/16	± 0° 30'	UNDER 0.251 +.004 -.003
.XXX ±.005			0.251 to 0.500 +.006 -.003
			OVER 0.500 +.008 -.003

PART NUMBER:	
MATERIAL:	
APPLIED FINISH:	
UNIT OF MEASURE:	
APPROVALS	DATE
DRAWN: BECKY NELSON	5-30-07
CHECKED: DON MILLS	5-30-07
APPROVED: DON MILLS	5-30-07

**JANUS INTERNATIONAL GROUP, LLC.**  
 135 JANUS INTERNATIONAL BLVD. TEMPLE, GA 30179-4435  
 770-562-2850/Fax 770-562-2264  
 © 2017 Janus International Group, LLC. All Rights Reserved

**CERTIFIED WIND LOAD RATED**  
 26 GA SERIES 1100 DOOR ASSEMBLY  
 MAX. SIZE 8'-8" X 14'-0"

SIZE <b>B</b>	DRAWING NUMBER: <b>T1012</b>	REV: <b>F</b>
SCALE: NONE	SHEET: 1	OF: 2

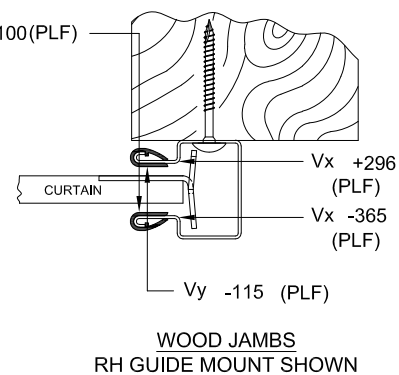
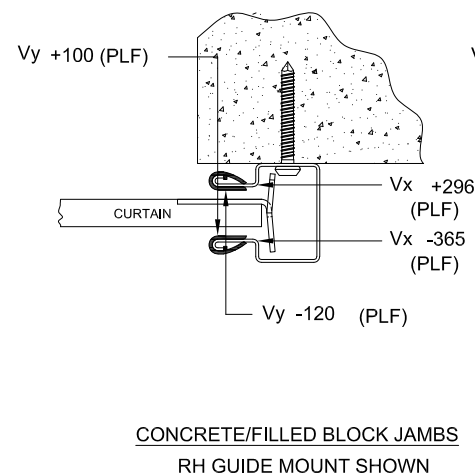
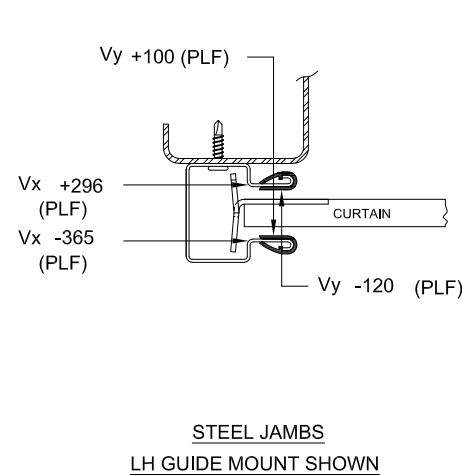
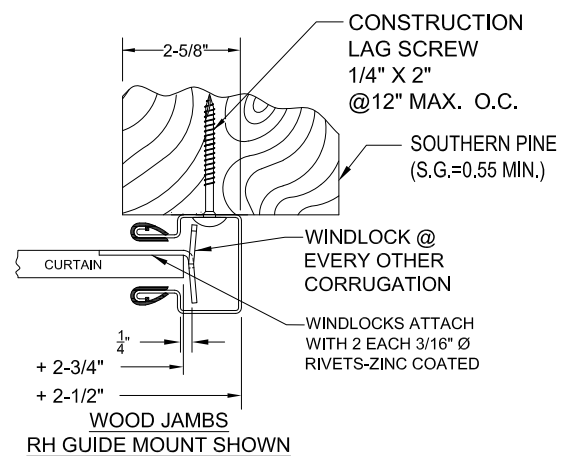
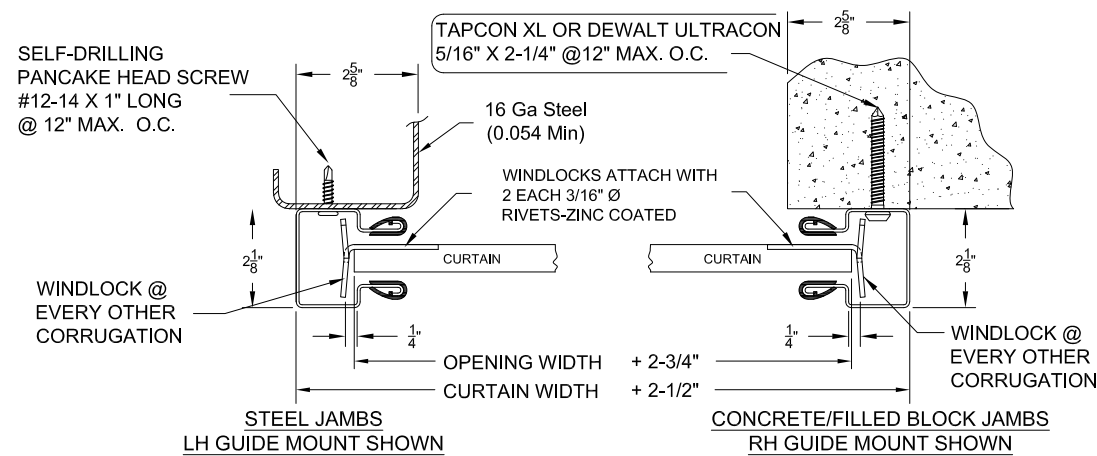

**SUPERIMPOSED LOAD DIAGRAM**

**GENERAL NOTES:**

1. TESTING:
  - 1.1. TESTED PER DASMA 108 (STATIC).
  - 1.2. TESTING PERFORMED IN AN INDEPENDENT LAB.
  - 1.3. DESIGN PRESSURE: +24.4/-27.0 PSF AT 8'-8" OPENING WIDTH.
2. DESIGN WINDLOAD REQUIREMENTS FOR BUILDING OPENINGS SHALL BE DETERMINED BY OTHERS.
3. SUPERIMPOSED LOADS ON THE JAMBS FROM THIS DOOR ARE DESIGNATED AS Vx and Vy HEREIN. OTHERS SHALL VERIFY ADEQUACY OF BUILDING STRUCTURE TO RESIST SUPERIMPOSED LOADS Vx, Vy.
4. ALL WELDING SHALL BE PREFORMED BY QUALIFIED WELDERS IN ACCORDANCE WITH A.W.S. SPECIFICATIONS. WELDING ELECTRODES SHALL CONFORM TO A.W.S. A5.1 GRADE E-70
5. DOORS SHALL BE PROVIDED WITH LOCK MECHANISMS AT THE OPTION OF THE OWNER
6. ALL BOLTS AND WASHERS SHALL BE GALVANIZED OR STAINLESS STEEL WITH A MINIMUM TENSILE STRENGTH OF 60 KSI.
7. ANCHOR NOTES:
  - 7.1. EMBEDMENT LENGTH DOES NOT INCLUDE STUCCO FINISH.
  - 7.2. FOR HOLLOW BLOCK, FILL ALL CELLS @ANCHOR WITH 2000 PSI GROUT.
  - 7.3. CONCRETE TO BE 2500 PSI MIN.
  - 7.4. ANCHORS SHALL BE INSTALLED IN ACCORDANCE WITH MANUFACTURER'S SPECIFICATIONS
  - 7.5. APPROVED CONCRETE AND FILLED-CMU ANCHORS:
    - 7.5.1. 5/16" TAPCON XL
    - 7.5.2. 5/16" DEWALT ULTRACON
8. DOOR OPERATION TYPE MAY BE PUSH-UP, HAND CHAIN, OR ELECTRIC.
9. GUIDE-TO-JAMB ATTACHMENT FASTENERS BEGIN 4" FROM FLOOR AND END 3-1/2" BELOW THE TOP OF WALL OPENING.
10. COMPLIES WITH THE WINDLOAD REQUIREMENTS OF IBC/IRC 2018

THESE CONFIDENTIAL DOCUMENTS SUBMITTED BY JANUS CONTAIN INFORMATION OF A PROPRIETARY NATURE AND MAY NOT BE REPRODUCED OR USED TO MANUFACTURE ANYTHING IN PART OR IN WHOLE FOR ANY PURPOSE OTHER THAN THAT WHICH IS NECESSARY FOR PREPARATION OF BIDS OF ENGINEERING WITHOUT THE EXPRESS PERMISSION OF JANUS WHICH MAY RECALL DOCUMENTS AT ANY TIME.

UNLESS OTHERWISE SPECIFIED DIMENSIONS ARE IN INCHES AND TOLERANCES ARE:

DECIMAL	FRACTIONS	ANGLES	HOLE DIAMETERS
.XX ±.03	± 1/16	± 0° 30'	UNDER 0.251 +.004 -.003
.XXX ±.005			0.251 to 0.500 +.006 -.003
			OVER 0.500 +.008 -.003

PART NUMBER:	
MATERIAL:	
APPLIED FINISH:	
UNIT OF MEASURE:	
APPROVALS	DATE
DRAWN: BECKY NELSON	5-30-07
CHECKED: DON MILLS	5-30-07
APPROVED: DON MILLS	5-30-07

**JANUS INTERNATIONAL GROUP, LLC.**  
 135 JANUS INTERNATIONAL BLVD. TEMPLE, GA 30179-4435  
 770-562-2850/Fax 770-562-2264  
 © 2017 Janus International Group, LLC. All Rights Reserved

**CERTIFIED WIND LOAD RATED**  
 26 GA SERIES 1100 DOOR ASSEMBLY  
 MAX. SIZE 8'-8" X 14'-0"

SIZE	DRAWING NUMBER:	REV:
<b>B</b>	<b>T1012</b>	<b>F</b>
SCALE:	NONE	SHEET: 2 OF 2