

LARGE MISSILE IMPACT RESISTANT

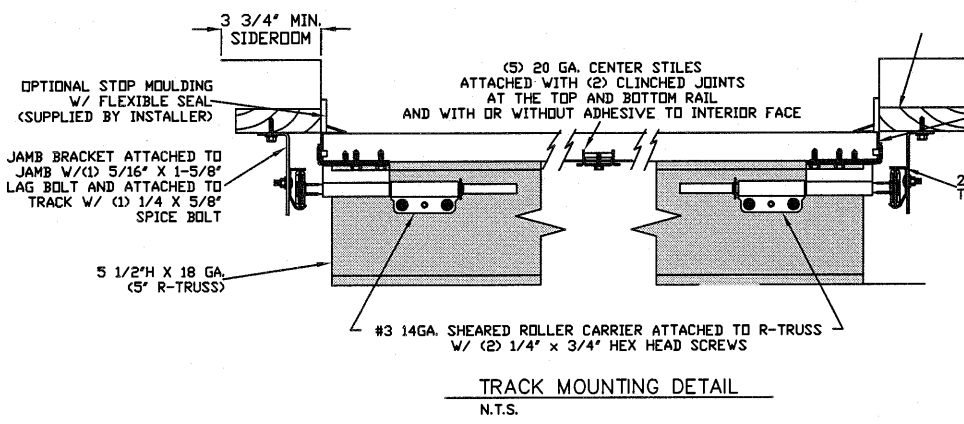

THE METHOD OF TESTING WAS IN SUBSTANTIAL CONFORMANCE WITH THE PROCEDURE DESCRIBED IN ASTM E330, E1886, E1996, F588, AND DASMA 108, 115. THE PRESSURES SHOWN ON THE DRAWINGS WERE CALCULATED USING ASCE 7-98/02/05 WITH THE FOLLOWING PARAMETERS (5 FEET OF DOOR WIDTH IN THE END ZONE, ROOF AT ANY SLOPE, AND I=1.0):

WIND SPEED (MPH)	156	142	135	129	123
EXPOSURE LEVEL	B	C	C	D	D
MEAN ROOF HEIGHT	30'	15'	25'	15'	25'

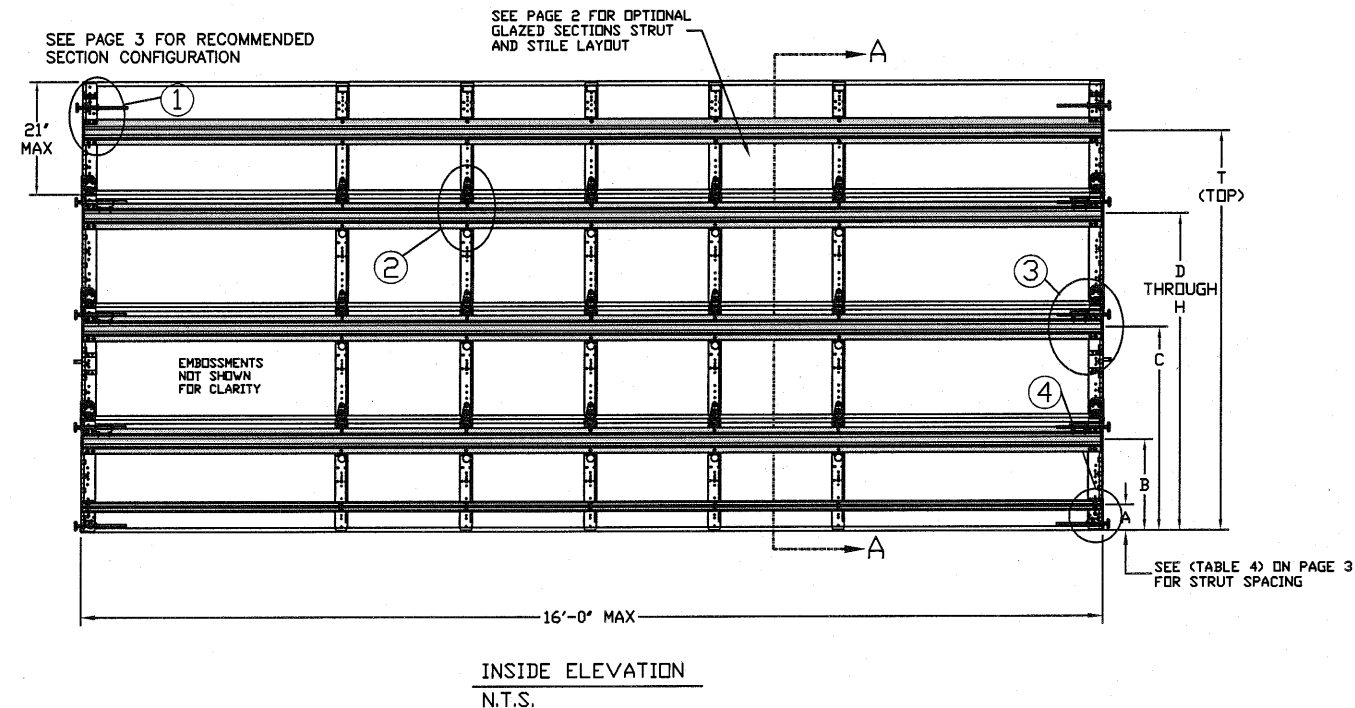
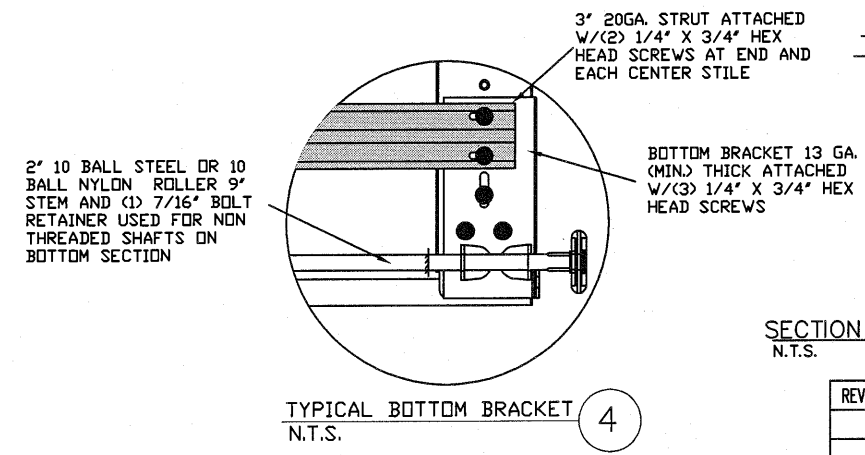
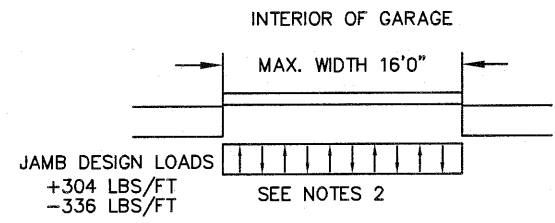

- SPECIFICATIONS AND NOTES
- ALL THE LOAD FROM THE DOOR IS TRANSFERRED TO THE VERTICAL TRACK. FROM THE TRACK THE LOAD IS TRANSFERRED TO THE VERTICAL JAMBS. THE HORIZONTAL JAMB OR HEADER RECEIVES NO PORTION OF THE LOAD TRANSFERRED FROM THE DOOR.
 - EACH VERTICAL JAMB RECEIVES MAXIMUM DESIGN LOADS OF: +304 LBS/FT & -336 LBS/FT
 - DOORS AND HARDWARE WILL BE DESIGNED, MANUFACTURED AND INSTALLED WITH STANDARDS AS SET FORTH BY DASMA.
 - DOOR SECTIONS SHALL BE 25 GA. MIN. (.019") ROLLED FORMED LIGHT COMMERCIAL QUALITY
 - SUPPORTING STRUCTURAL ELEMENTS SHALL BE DESIGNED BY A REGISTERED PROFESSIONAL ENGINEER FOR WIND LOADS INDICATED ON THIS DRAWING IN ADDITION TO OTHER LOADINGS.
 - AMARR MANUFACTURES AND DISTRIBUTES GARAGE DOORS UNDER MANY BRAND LABELS. PLEASE SEE AMARR-MANUFACTURED PRIVATE LABEL CHART FOR REFERENCE OF EQUIVALENT PRODUCTS FOR WINDLOAD APPROVAL
 - REFER TO TABLES ON THE PAGE 3 FOR ADDITIONAL DOOR WIDTHS AND THEIR DESIGN PRESSURES
 - PANEL STAMP DOES NOT EFFECT WINDLOAD CAPABILITIES.

REV	DESCRIPTION OF REVISIONS	DATE	BY

MAX SIZE WIDTH 16' HEIGHT 14'

DESIGN LOADS +38.0 PSF -42.0 PSF

TEST LOADS +57.0 PSF -63.0 PSF

LARGE MISSILE IMPACT RESISTANT

Thomas L. Shelmerdine, PE (TX PE #85829) Structural Solutions, PA (TX Firm #F-004063)

STATE OF TEXAS
THOMAS L. SHELMEARDINE
85829
LICENSED PROFESSIONAL ENGINEER

TX
Amarr
GARAGE DOORS

165 CARRIAGE COURT WINSTON-SALEM, N.C. 27105

MODEL #650 OAK SUMMIT SERIES 1000 & 2000
MODEL #600 STRATFORD SERIES 1000 & 2000
MODEL #950 HERITAGE SERIES 1000 & 2000

SIZE	DRAWN BY	RLR	DATE	2/5/14	DRAWING NUMBER
B	CHECKED BY		DATE		IRC-6016-156-26-1

SHEET 1 OF 3

5921-G.W. Friendly Ave., Greensboro, NC 27410

TABLE 1

DOOR HEIGHT	TRACK ATTACHMENT											SPLICE S
	A	B	C	D	E	F	G	H	I	J	K	
6' 6"	3.5"	21"	34"	44"	57"							70"
7'	3.5"	21"	37"	47"	63"							76"
7' 6"	3.5"	18"	31"	41"	54"	72"						82"
8'	3.5"	21"	34"	44"	57"	75"						88"
8' 6"	3.5"	21"	37"	47"	63"	81"						94"
9'	3.5"	18"	31"	41"	54"	72"	85"					100"
9' 6"	3.5"	21"	34"	44"	57"	75"	88"					106"
10'	3.5"	21"	37"	47"	63"	81"	94"					112"
10' 6"	3.5"	21"	37"	47"	63"	79"	89"	105"				118"
11'	3.5"	21"	34"	44"	57"	75"	88"	98"	111"			124"
11' 6"	3.5"	21"	37"	47"	63"	81"	94"	104"	117"			130"
12'	3.5"	21"	37"	47"	63"	79"	89"	105"	118"			136"
12' 6"	3.5"	21"	34"	44"	57"	75"	88"	98"	111"	129"		142"
13'	3.5"	21"	37"	47"	63"	81"	94"	104"	117"	135"		148"
13' 6"	3.5"	21"	37"	47"	63"	79"	89"	105"	118"	141"		154"
14'	3.5"	21"	37"	47"	63"	79"	89"	105"	121"	131"	147"	160"

ALL TRACK ATTACHMENT SPACING +/- 1" WITH SYP NO. 2 OR BETTER ONLY

TABLE 3

DOOR HEIGHT	SECTION HEIGHTS							
	Btm	#2	#3	#4	#5	#6	#7	#8
6' 0"	18"	18"	18"	18"				
6' 6"	21"	18"	18"	21"				
7' 0"	21"	21"	21"	21"				
7' 6"	18"	18"	18"	18"	18"			
8' 0"	21"	18"	18"	18"	21"			
8' 6"	21"	21"	21"	18"	21"			
9' 0"	18"	18"	18"	18"	18"	18"		
9' 6"	21"	18"	18"	18"	18"	21"		
10' 0"	21"	21"	21"	18"	18"	21"		
10' 6"	21"	21"	21"	21"	21"	21"		
11' 0"	21"	18"	18"	18"	18"	18"	21"	
11' 6"	21"	21"	21"	18"	18"	18"	21"	
12' 0"	21"	21"	21"	21"	21"	18"	21"	
12' 6"	21"	18"	18"	18"	18"	18"	18"	21"
13' 0"	21"	21"	21"	18"	18"	18"	18"	21"
13' 6"	21"	21"	21"	21"	21"	18"	18"	21"
14' 0"	21"	21"	21"	21"	21"	21"	21"	21"

TABLE 2

Section Width (ft)	Panel Type	Center Stile Locations (Measured from Left Edge)				
		1st (in)	2nd (in)	3rd (in)	4th (in)	5th (in)
		10' 0" Short	48.41	71.59		
10' 0" Long	30.00	60.00	90.00			
10' 0" Oak Summit	30.63	60.00	89.38			
12' 0" Short	48.81	72.00	95.19			
12' 0" Long	49.63	72.00	94.38			
12' 0" Oak Summit	48.31	72.00	95.69			
12' 2" Short	49.64	73.00	96.36			
12' 2" Long	50.08	73.00	95.92			
12' 2" Oak Summit	49.06	73.00	96.94			
12' 4" Short	50.64	74.00	97.36			
12' 4" Long	51.08	74.00	96.92			
12' 4" Oak Summit	49.81	74.00	98.19			
12' 6" Short	50.67	75.00	99.33			
12' 6" Long	51.17	75.00	98.83			
12' 6" Oak Summit	50.56	75.00	99.44			
12' 8" Short	51.67	76.00	100.33			
12' 8" Long	52.10	76.00	99.90			
12' 8" Oak Summit	51.31	76.00	100.69			
12' 10" Short	52.25	77.00	101.75			
12' 10" Long	53.10	77.00	100.90			
12' 10" Oak Summit	52.06	77.00	101.94			
13' 0" Short	53.00	78.00	103.00			
13' 0" Long	54.10	78.00	101.90			
13' 0" Oak Summit	52.81	78.00	103.19			
13' 2" Short	54.00	79.00	104.00			
13' 2" Long	55.10	79.00	102.90			
13' 2" Oak Summit	53.56	79.00	104.44			
13' 4" Short	54.40	80.00	105.60			
13' 4" Long	54.90	80.00	105.10			
13' 4" Oak Summit	54.31	80.00	105.69			
13' 6" Short	55.40	81.00	106.60			
13' 6" Long	55.90	81.00	106.10			
13' 6" Oak Summit	55.06	81.00	106.94			
13' 8" Short	56.40	82.00	107.60			
13' 8" Long	56.63	82.00	107.38			
13' 8" Oak Summit	55.81	82.00	108.19			
13' 10" Short	57.16	83.00	108.71			
13' 10" Long	57.17	83.00	108.83			
13' 10" Oak Summit	56.56	83.00	109.44			
14' 0" Short	57.76	84.00	110.11			
14' 0" Long	58.63	84.00	109.38			
14' 0" Oak Summit	57.31	84.00	110.69			
14' 2" Short	58.85	85.00	111.41			
14' 2" Long	59.17	85.00	110.83			
14' 2" Oak Summit	58.06	85.00	111.94			
14' 4" Short	59.16	86.00	112.71			
14' 4" Long	60.17	86.00	111.83			
14' 4" Oak Summit	58.81	86.00	113.19			
14' 6" Short	59.86	87.00	114.01			
14' 6" Long	61.17	87.00	112.83			
14' 6" Oak Summit	59.56	87.00	114.44			
14' 8" Short	60.56	88.00	115.31			
14' 8" Long	64.81	88.00	109.59	131.19		
14' 8" Oak Summit	60.31	88.00	115.69			
14' 10" Short	61.26	89.00	116.61			
14' 10" Long	65.60	89.00	110.70	132.40		
14' 10" Oak Summit	61.06	89.00	116.94			
15' 0" Short	61.94	90.00	103.97	117.94		
15' 0" Long	66.60	90.00	111.70	133.40		
15' 0" Oak Summit	63.63	90.00	118.19	146.38		
15' 2" Short	62.66	91.00	105.11	119.21		
15' 2" Long	67.60	91.00	112.70	134.40		
15' 2" Oak Summit	64.13	91.00	119.44	147.88		
15' 4" Short	63.60	92.00	104.80	130.40		
15' 4" Long	67.25	92.00	114.38	136.75		
15' 4" Oak Summit	64.63	92.00	120.69	149.38		
15' 6" Short	64.62	93.00	116.19	139.38		
15' 6" Long	67.60	93.00	115.70	138.40		
15' 6" Oak Summit	64.42	93.00	115.79	138.58		
15' 8" Short	67.62	94.00	117.19	140.38		
15' 8" Long	68.60	94.00	116.70	139.40		
15' 8" Oak Summit	68.02	94.00	116.99	139.98		
15' 10" Short	68.62	95.00	118.19	141.38		
15' 10" Long	69.17	95.00	117.92	140.83		
15' 10" Oak Summit	68.62	95.00	118.19	141.38		
16' 0" Short	69.62	96.00	119.19	142.38		
16' 0" Long	70.60	96.00	118.70	141.40		
16' 0" Oak Summit	69.42	96.00	119.79	143.58		

WOOD JAMB ATTACHMENT TO STRUCTURE

2 X 6 VERTICAL JAMB ATTACHMENT TO WOOD FRAME STRUCTURE
 5/16" X 3" LAG SCREWS STARTING 6" FROM ENDS THEN 16" O.C. (1 1/2" EMBEDMENT)

2 X 6 VERTICAL JAMB ATTACHMENT TO 2,000 PSI CONCRETE
 HILTI KWIK BOLT 3/8" X 4" STARTING 6" FROM ENDS THEN 24" O.C. (2 1/2" EMBEDMENT)
 HILTI SLEEVE ANCHOR 3/8" X 2-3/4" STARTING 6" FROM ENDS THEN 14" O.C. (1 1/4" EMBEDMENT)
 ITW/RAMSET REDHEAD (TRU-BOLT) 3/8" X 4" STARTING 6" FROM ENDS THEN 24" O.C. (2 1/2" EMBEDMENT)

2 X 6 VERTICAL JAMB ATTACHMENT TO HOLLOW C-90 BLOCK
 SIMPSON 1/4" X 3" TITEN SCREWS STARTING 6" FROM ENDS, USE PAIRS OF FASTENERS (3" APART) AT 8" O.C. (1 1/2" EMBEDMENT)
 HILTI 1/4" X 2-3/4" KWIK-CON II+ SCREWS STARTING 6" FROM ENDS, USE PAIRS OF FASTENERS (3" APART) AT 8" O.C. (1 1/4" EMBEDMENT)

2 X 6 VERTICAL JAMB ATTACHMENT TO GROUTED C-90 BLOCK (2000 PSI GROUT)
 HILTI SLEEVE ANCHOR 3/8" X 2-3/4" STARTING 6" FROM ENDS THEN 16" O.C. (1 1/4" EMBEDMENT) (OR, USE FASTENERS FOR HOLLOW C-90 BLOCK)

*LAGS AND BOLTS CAN BE COUNTERSUNK TO PROVIDE A FLUSH MOUNTING SURFACE.
 *PREPARATION OF WOOD JAMBS BY OTHERS

TABLE 4

DOOR HEIGHT	STRUT SPACING (BASED ON RECOMMENDED SECTION CONFIGURATION)									TOP
	A	B	C	D	E	F	G	H	T	
6' 6"	5 1/2"	16"	34"	52"						70 1/2"
7'	5 1/2"	16"	37"	58"						76 1/2"
7' 6"	5 1/2"	13"	31"	49"	67"					82 1/2"
8'	5 1/2"	16"	34"	52"	70"					88 1/2"
8' 6"	5 1/2"	16"	37"	58"	76"					94 1/2"
9'	5 1/2"	13"	31"	49"	67"	85"				100 1/2"
9' 6"	5 1/2"	16"	34"	52"	70"	88"				106 1/2"
10'	5 1/2"	16"	37"	58"	76"	94"				112 1/2"
10' 6"	5 1/2"	16"	37"	58"	79"	100"				118 1/2"
11'	5 1/2"	16"	34"	52"	70"	88"	106"			124 1/2"
11' 6"	5 1/2"	16"	37"	58"	76"	94"	112"			130 1/2"
12'	5 1/2"	16"	37"	58"	79"	100"	118"			136 1/2"
12' 6"	5 1/2"	16"	34"	52"	70"	88"	106"	124"		142 1/2"
13'	5 1/2"	16"	37"	58"	76"	94"	112"	130"		148 1/2"
13' 6"	5 1/2"	16"	37"	58"	79"	100"	118"	136"		154 1/2"
14'	5 1/2"	16"	37"	58"	79"	100"	121"	142"		160 1/2"

* ADDITIONAL STRUTS MAY BE ADDED TO DOOR WHEN GLAZED FOR COUNTERBALANCE PURPOSES

REV	DESCRIPTION OF REVISIONS	DATE	BY

MAX SIZE WIDTH 16" HEIGHT 14"

DESIGN LOADS +38.0 PSF -42.0 PSF

TEST LOADS +57.0 PSF -63.0 PSF

LARGE MISSILE IMPACT RESISTANT

Thomas L. Shelmerdine, PE (TX PE #85829) Structural Solutions, PA (TX Firm #F-004065)

TX

Amarr
GARAGE DOORS

165 CARRIAGE COURT WINSTON-SALEM, NC. 27105

MODEL #650 OAK SUMMIT SERIES 1000 & 2000
 MODEL #600 STRATFORD SERIES 1000 & 2000
 MODEL #950 HERITAGE SERIES 1000 & 2000

SIZE	DRAWN BY	RLR	DATE	2/5/14	DRAWING NUMBER
B	CHECKED BY		DATE		IRC-6016-156-26-1

SHEET 3 OF 3