

CLOPAY MODEL 3200 (24 GA MIN EXT SKIN), CLOPAY MODEL 3220 (20 GA MIN EXT SKIN)
 HOLMES MODEL 240, 240G (24 GA MIN EXT SKIN)

REV	DATE	DESCRIPTION
10	06/2013	REMOVED GLAZING OPTION.
11	08/2016	REMOVED WIND SPEED TABLE.

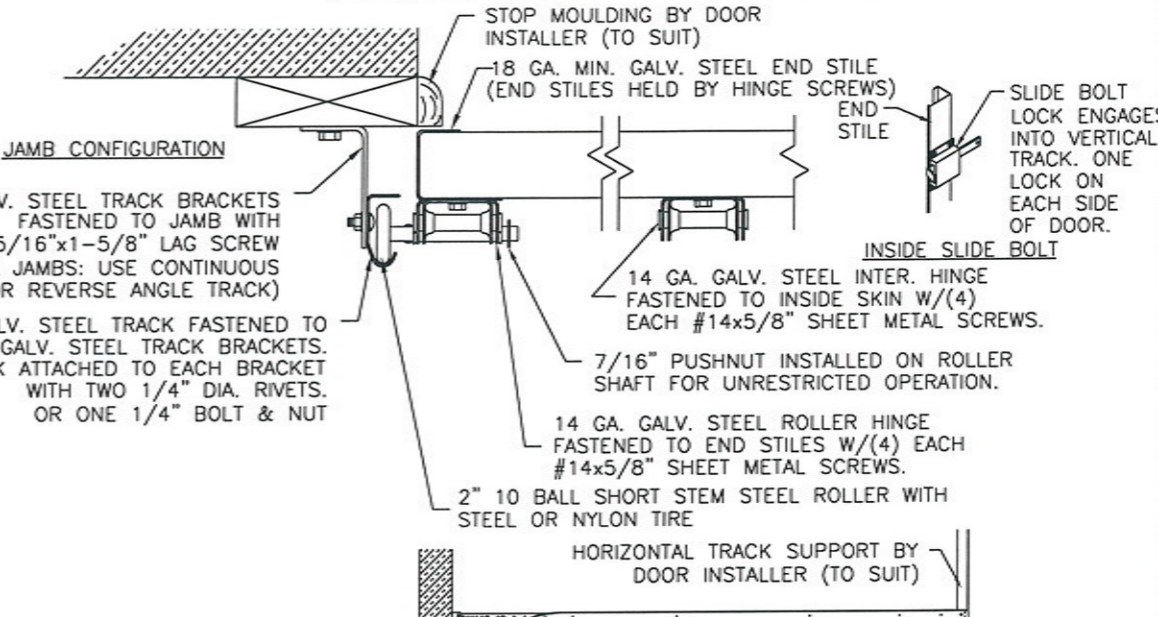
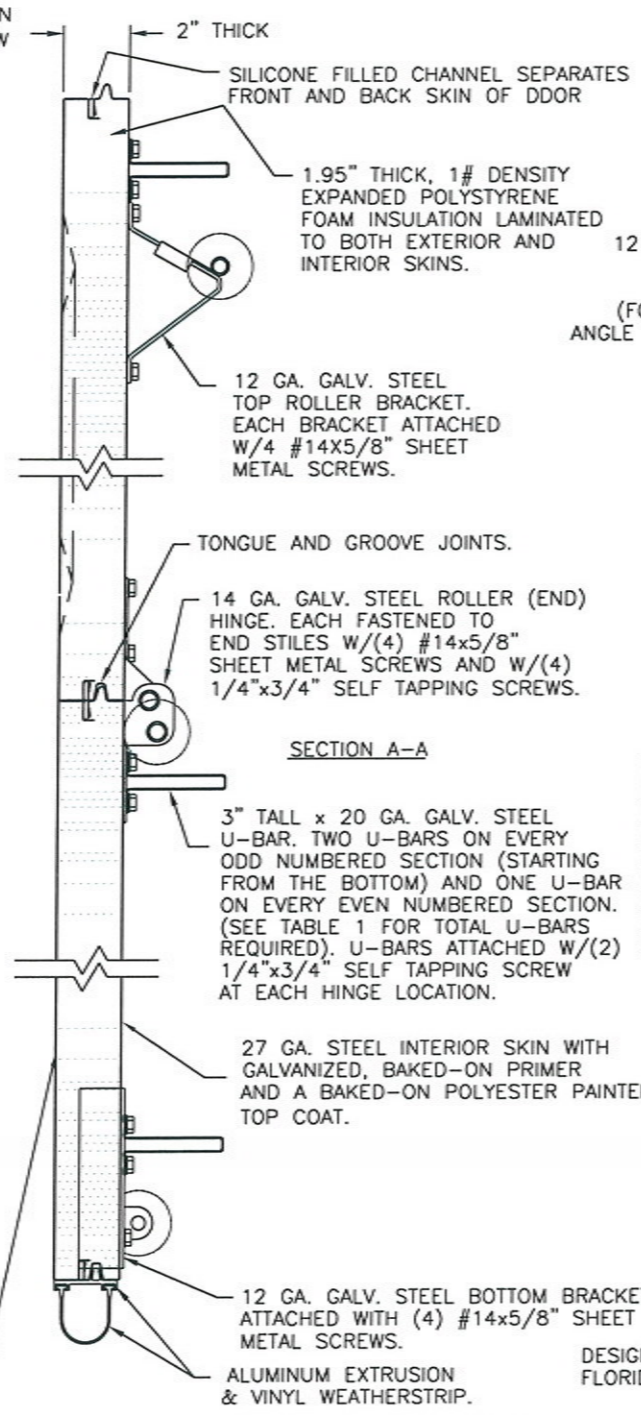
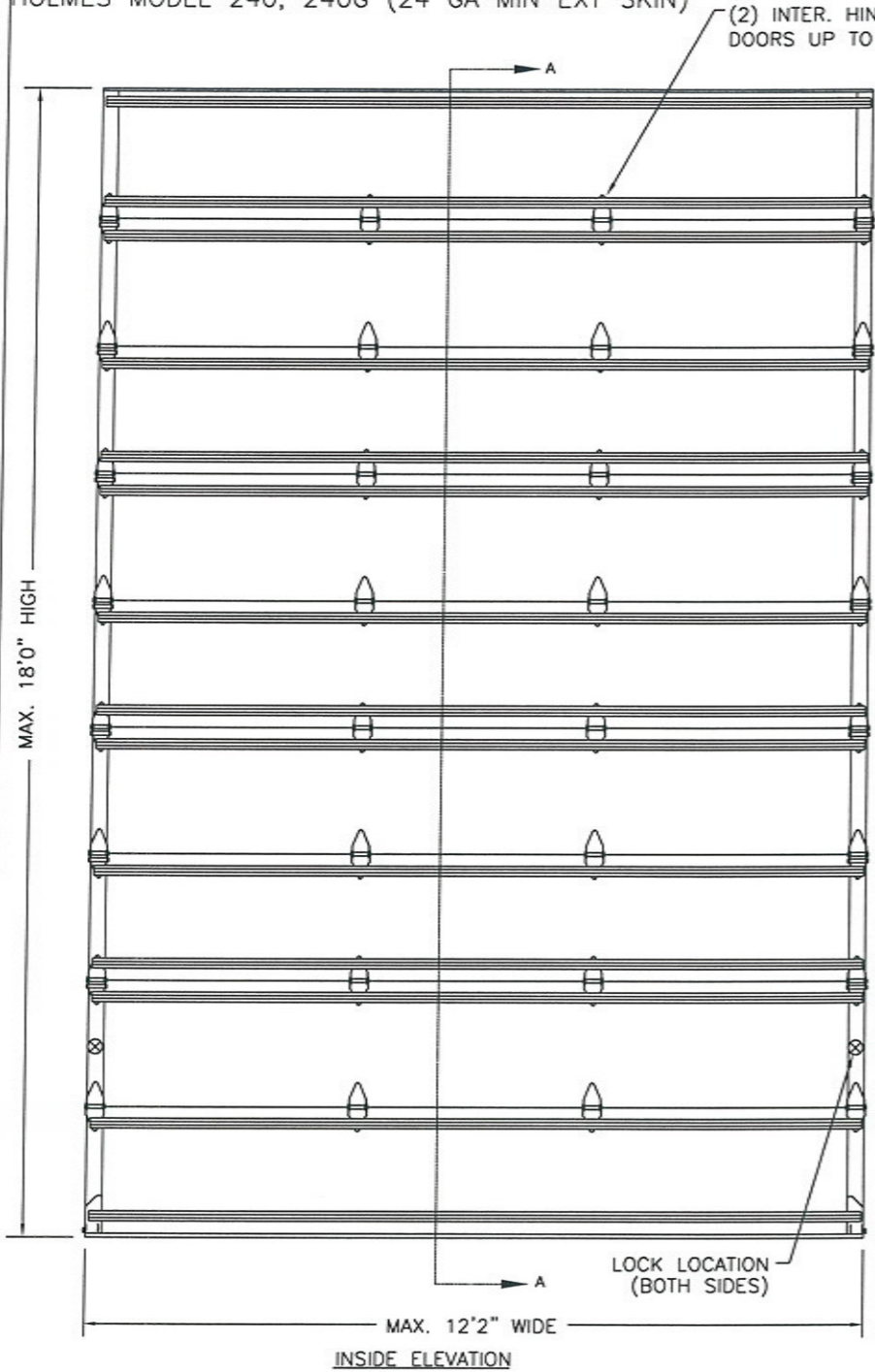

TABLE 1

DOOR HEIGHT	TOTAL U-BARS REQUIRED
4'3" TO 6'0"	5
6'3" TO 8'0"	6
8'3" TO 10'0"	8
10'3" TO 12'0"	9
12'3" TO 14'0"	11
14'3" TO 16'0"	12
16'3" TO 18'0"	14

MAX. SECTION HEIGHT: 24"

NOTE: DOUBLE TRACK LOW HEADROOM, HI-LIFT TRACK, FOLLOW-THE-ROOF TRACK, AND VERTICAL LIFT TRACK ARE AVAILABLE OPTIONS. 3" TRACK ALSO AVAILABLE.

DESIGN ENGINEER: MARK WESTERFIELD, P.E.
 FLORIDA P.E. #48495, NC P.E. #23832, TEXAS P.E. #91513
 DESIGN LOADS: +40.0 PSF & -40.0 PSF
 TEST LOADS: +60.0 PSF & -60.0 PSF

THE OPTIONAL GLAZING SHOWN ON THIS DRAWING MEETS THE WIND LOAD REQUIREMENTS OF THE FLORIDA BUILDING CODE OR INTERNATIONAL BUILDING CODE BUT DOES NOT MEET THE IMPACT RESISTANT REQUIREMENT FOR WINDBORNE DEBRIS REGIONS (REF. CHAPTER 16 FBC/IBC)

THE SUPPORTING STRUCTURAL ELEMENTS ARE TO BE DESIGNED BY THE BUILDING ARCHITECT OR ENGINEER OF RECORD FOR THE LOADS SHOWN ON THIS DRAWING.

- JAMB ATTACHMENT PREPARATION OF JAMBS BY OTHERS:**
- MASONRY OPENINGS (2 OPTIONS):**
- 1) 1/4"x1-3/4" MIN. EMBED TAPCON CONCRETE ANCHOR. START AT 7" FROM BOTTOM AND 14" O.C.
 - 2) 3/8"x1-1/2" MIN. EMBED SLEEVE ANCHOR BOLT. START AT 7" FROM BOTTOM AND 16" O.C.
- STEEL OPENINGS (2 OPTIONS):**
- 1) 1/8"x1" LONG FILLET WELD (E60XX ELECTRODE MIN.). WELD TO BE LOCATED VERTICALLY ON ANGLE AT 24" CENTER AND TACK WELD TOE OF ANGLE AT SAME SPACING.
 - 2) 1/4"x3/4" SELF TAPPING SCREW. START AT 7" FROM BOTTOM AND 22" O.C.
- WOOD FRAME OPENINGS (1 OPTION):**
- 1) 3/8" X 1-1/2" MIN. EMBED LAG SCREW W/ 1-1/8" DIA. WASHER. MIN. 24" O.C.

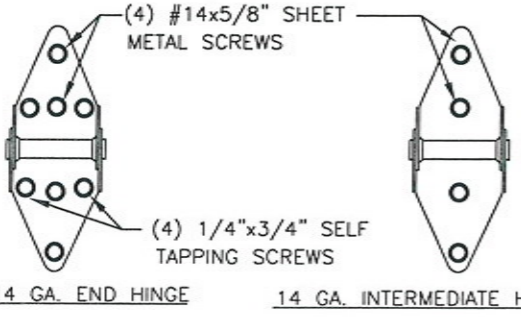

Professional Engineer Seal for Mark W. Westerfield, State of Texas, No. 91513, dated 08/28/16.

Clopay
 Building Products Company

CLOPAY BUILDING PRODUCTS COMPANY
 8585 DUKE BLVD.
 MASON, OH 45040
 (513) 770 - 4800
 Clopay Corporation All Rights Reserved.

MANUFACTURING PRODUCT CODE: MPC: C-DS1E-1F447	WINDLOAD RATING W6	MAX DOOR SIZE: 12'2"W x 18'0"H
DATE: 8/28/96	DESCRIPTION: COMM 2" EPS: +40/-40 PSF DESIGN	DRAWING NUMBER: B 101678
DRAWN BY: MWW	CHECKED BY:	