

REVISIONS				
EN	REV	DESCRIPTION	DATE	APPROVAL
32177	E	REVISED PER PCR	10/21/19	JQ
32499	F	DRAWING UPDATES	10/2/20	TC
32499	G	ADDED '2018' TO NOTE 1	10/23/20	TC

- NOTES**
- DESIGNED AND TESTED IN ACCORDANCE WITH WIND LOAD PROVISIONS OF THE FLORIDA BUILDING CODE AND THE 2018 INTERNATIONAL BUILDING CODE PER ANSI/DASMA 108 AND ANSI/DASMA 115. PROFESSIONAL ENGINEER'S SEAL PROVIDED ONLY FOR VERIFICATION OF WIND LOAD CONSTRUCTION DETAILS.
  - PRESSURES LISTED AS POSITIVE/NEGATIVE (DESIGN).
  - SECTION HEIGHTS MAY VARY TO CREATE VARIOUS DOOR HEIGHTS, 30'-1/2" MAXIMUM SECTION HEIGHT.
  - LIFT CLEARANCE OR FULL VERTICAL TRACK MAY ALSO BE USED. LOW HEADROOM TRACK MAY BE USED WITH EITHER DRAWBAR OPERATOR OR LOCK. LOW HEAD ROOM USES A 7/16" DIAMETER ROLLER SHAFT.
  - FASTENING METHODS (TRACK TO WALL), SPACING BASED ON BRACKET SPACING (SEE CHART BELOW):

- JAMB BRACKETS (TYP WOOD JAMBS) STYLE TRACK-- 5/16" x 1 3/4" LAG BOLT, OR EQUIVALENT.
- ALTERNATE ANGLE MOUNT--SEE SHEET 2
- GLAZING IS 1/4" POLYCARBONATE WITH A MAX GLAZING SIZE OF 23" HEIGHT BY 50" WIDTH. GLAZING RETAINER TO BE ATTACHED TO SECTION WITH #8 X 1" SCREWS WITH A MAX SPACING OF 6"
- STRUT OR ANGLE INSTALLATION:
  - FOR STRUTS ONLY-- USE 2 SCREWS AT BOTH END OF STRUT, 2 ON EACH CENTER HINGE LOCATION, AND 2 BETWEEN EACH HINGE.

- FOR ANGLES ATTACHED TO INTEGRAL FIN ONLY-- 1 - 5/16" BOLT EACH END AND WITH A MAX SPACING OF 13.5".
- FOR ANGLES ATTACHED TO BOTTOM RAIL ON BOTTOM SECTION -- 2 SCREWS AT BOTH ENDS AND 12" O.C.
- ANGLE LEG IS TURNED DOWN.
- 22 GAUGE X 16" LONG REINFORCING C-RAIL INSERTED IN THE ALUMINUM EXTRUSION AT THE BOTTOM OF EACH SECTION EXCEPT BOTTOM SECTION.
- FOR COMMERCIAL HARDWARE DETAILS SEE DRAWING 408717.

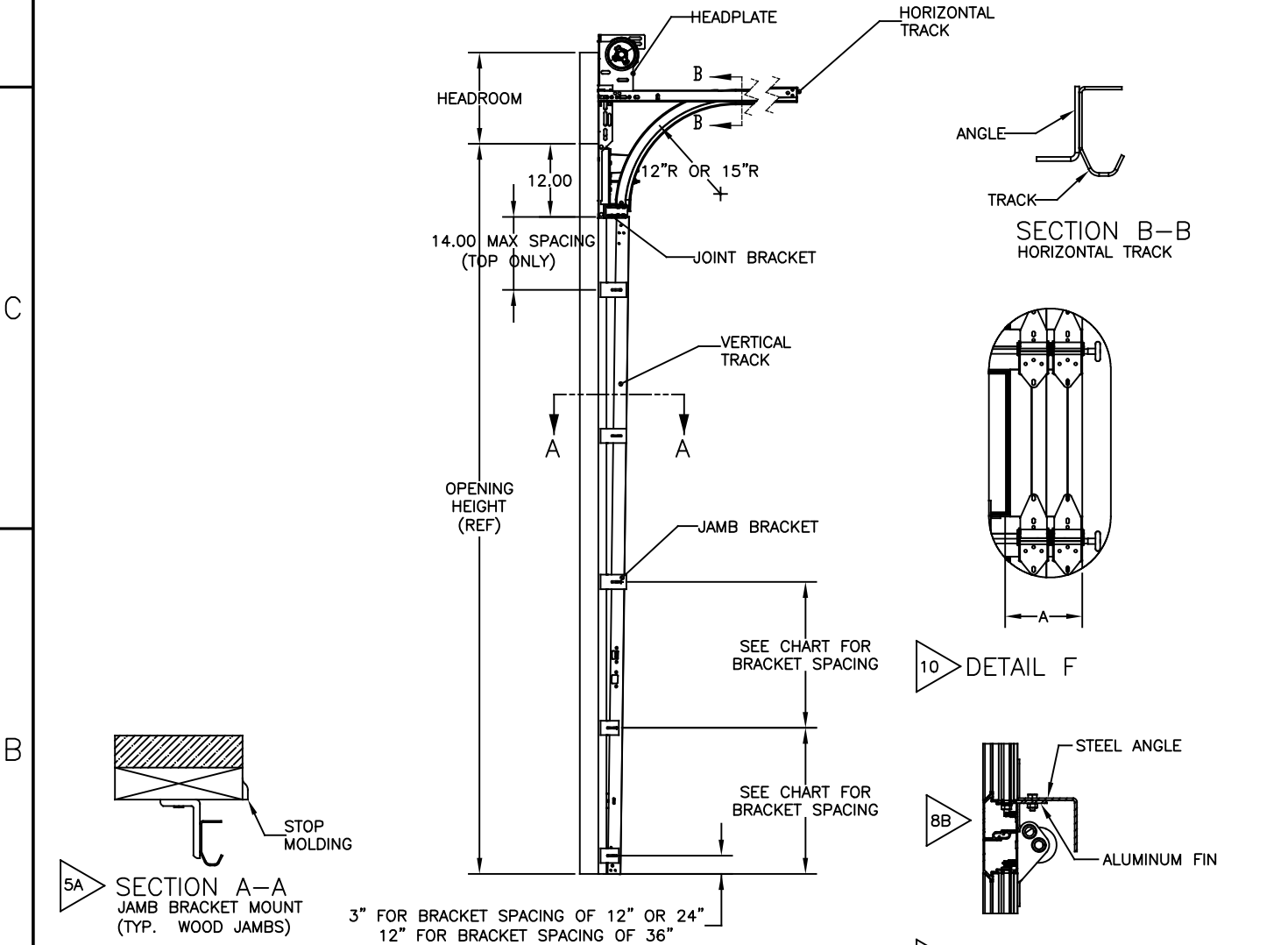

**5A SECTION A-A JAMB BRACKET MOUNT (TYP. WOOD JAMBS)**  
 3" FOR BRACKET SPACING OF 12" OR 24"  
 12" FOR BRACKET SPACING OF 36"

**SIDE ELEVATION OF WALL ANGLE TRACK OPTION**

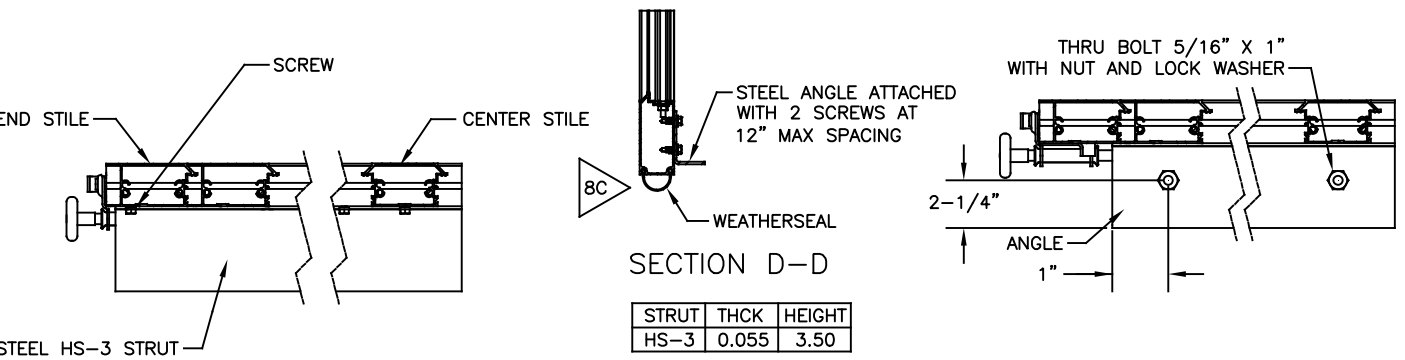

**8A SECTION C-C**

**9 SECTION E-E**

**8B SECTION G-G**

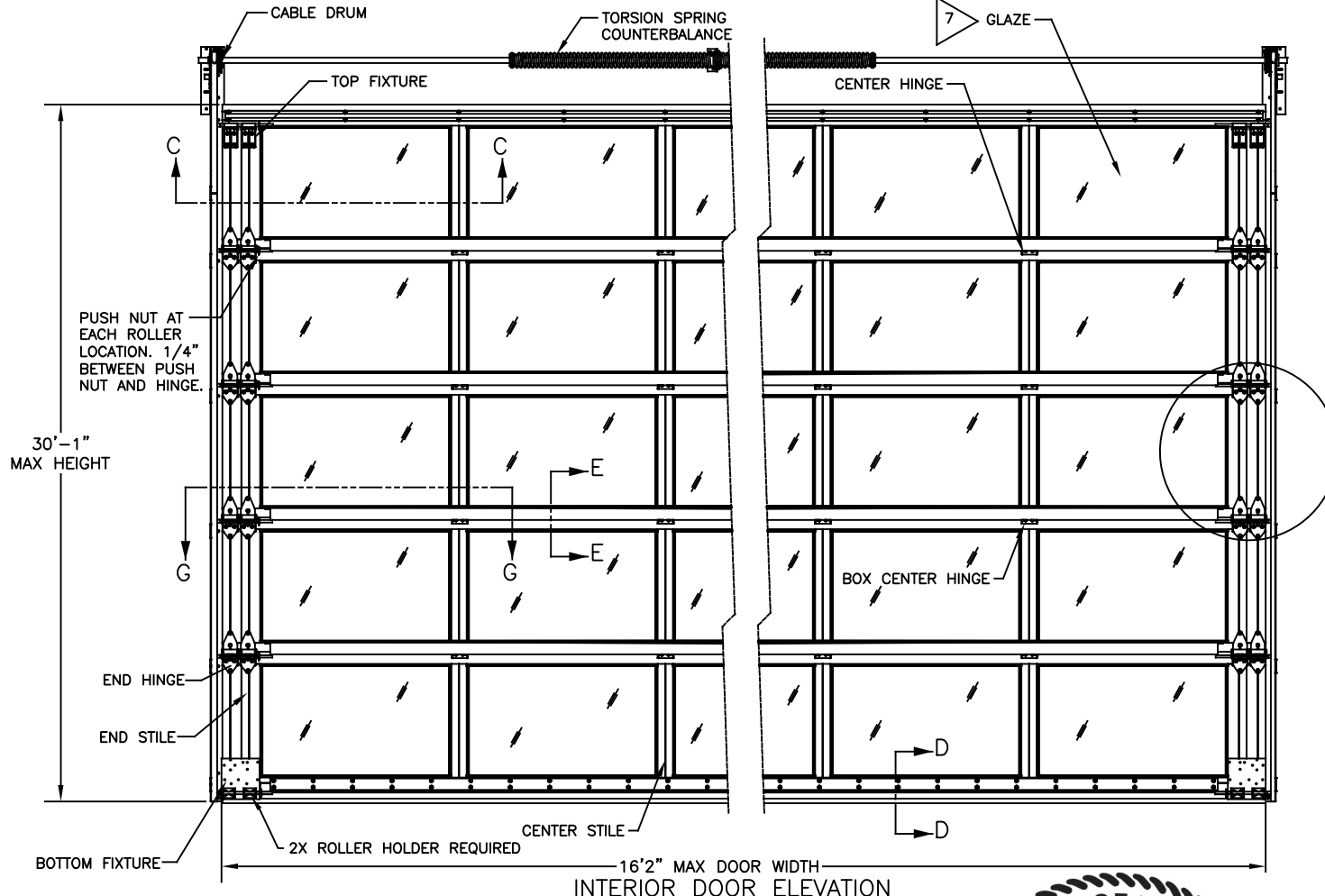

**16'2" MAX DOOR WIDTH**  
**30'-1" MAX HEIGHT**  
**INTERIOR DOOR ELEVATION**

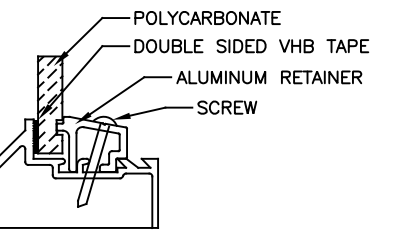

**7 SECTION E-E POLYCARBONATE RETAINER**

DOOR WIDTH	JAMB LOAD LB/FT (HEIGHT)
16'2"	+388/-437
14'2"	+340/-329
12'2"	+292/-329
10'2"	+244/-275
8'2"	+196/-221

DOOR WIDTH UP TO	IMPACT RESISTANT	END STILE QTY	ANGLE/SECT		STRUT AT TOP	ROLLER			TRACK		HARDWARE
			QTY	TYPE		TYPE	TIRE DIA.	STEM DIA.	BRKT/FSTNR MAX SPACING	VERTICAL GAGE	
16'2"	YES	DOUBLE	1	3 X 2 X 3/16	HS-3	TR-3	2"	7/16" 1144	12"	0.085"	STANDARD

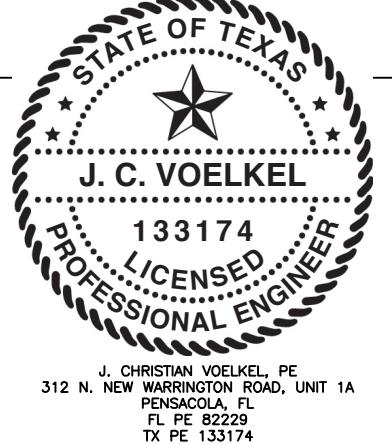

THE DRAWINGS AND ALL OTHER INFORMATION CONTAINED HEREIN ARE THE CONFIDENTIAL AND PROPRIETARY PROPERTY OF OVERHEAD DOOR CORPORATION AND ITS AFFILIATED COMPANIES. THIS DRAWING AND INFORMATION, IN WHOLE OR IN PART, MAY NOT BE COPIED IN ANY MANNER OR DISCLOSED TO ANYONE WITHOUT THE PRIOR WRITTEN CONSENT OF OVERHEAD DOOR CORPORATION. NO DISCLOSURE OF ANY OF THIS DRAWING OR INFORMATION IS INTENDED TO OPERATE AS A LICENSE OR AUTHORIZATION TO USE IT FOR ANY PURPOSE WITHOUT THE SPECIFIC WRITTEN CONSENT OF OVERHEAD DOOR CORPORATION.

REF DWG	USED ON	TOLERANCES UNLESS OTHERWISE SPECIFIED	FINISH	NAME	DATE	DRAWING TITLE
		WHOLE NUMBERS: ±.25	N/A	DRAWN BY:	10/2/20	WINDLOAD, 521, 9920
		.X ±.1		T CLARK		48/-54 PSF, 16'-2" MAX
		.XX ±.03		CHECKED BY:	10/2/20	DRAWING NUMBER
		.XXX ±.010	UNIT OF MEASURE	D KORNISH		D-411368
		ANGLES: ±.5	EA	APPROVED BY:	10/6/20	SCALE: N/A
		HOLES: ±		L KRUPKE		SHEET 1 OF 2

REVISIONS				
EN	REV	DESCRIPTION	DATE	APPROVAL
32177	E	REVISED PER PCR	10/21/19	JQ
32499	F	DRAWING UPDATES	10/2/20	TC
32499	G	ADDED '2018' TO NOTE 1	10/23/20	TC

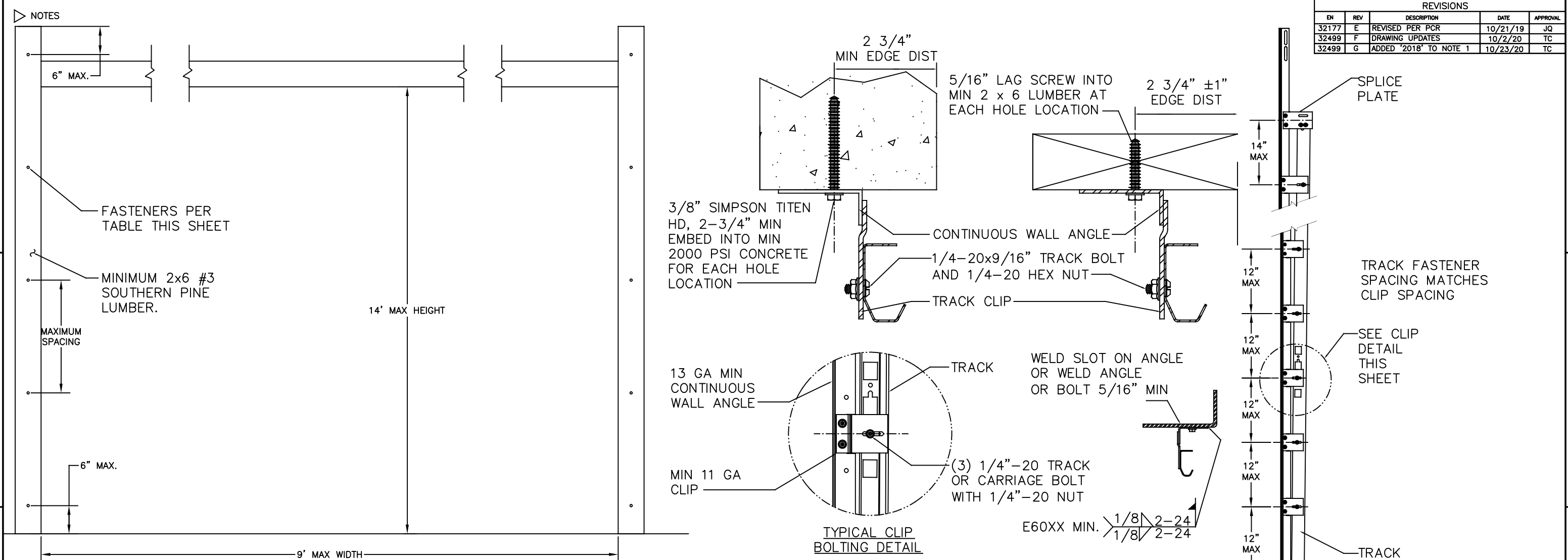

1. BASED ON 3/8" SIMPSON TITEN HEAVY DUTY SCREW ANCHOR WITH A 1" O.D. WASHER INTO CONCRETE WITH A MINIMUM EMBEDMENT DEPTH OF 2-3/4" AND A MINIMUM EDGE DISTANCE OF 2-3/4".
2. BASED ON 3/8" SIMPSON TITEN HEAVY DUTY SCREW ANCHOR WITH A 1" O.D. WASHER INTO GROUT FILLED CMU WITH A MINIMUM EMBEDMENT DEPTH OF 2-3/4", A MINIMUM EDGE DISTANCE OF 4", AND A MINIMUM END DISTANCE OF 4". CONCRETE MASONRY UNITS SHALL CONFORM TO ASTM C90 AND GROUT SHALL CONFORM TO ASTM C476.
3. BASED ON 3/8" DIAMETER x 3" LONG LAG SCREWS WITH 1" O.D. WASHERS WITH A 1-9/32" THREAD PENETRATION INTO SEASONED DRY WOOD SUPPORTING STRUCTURE.
4. PROVIDE QUANTITY OF SCREW ANCHORS OR LAG SCREWS AS REQUIRED TO MAINTAIN MAXIMUM SPACING AS SHOWN IN TABLE WITH A MINIMUM OF THREE (3) SCREW ANCHORS OR LAG SCREWS PER JAMB. SCREW ANCHORS OR LAG SCREWS AT TOP AND BOTTOM OF JAMB SHALL BE PLACED A MAXIMUM OF 6" FROM THE END OF THE JAMB.
5. LOAD PER JAMB CALCULATED TO BE A MAXIMUM OF +388.0/-436.5 LBS PER FOOT.
6. CHART INCLUDES A SAFETY FACTOR OF 4.
7. DOOR JAMB TO BE MINIMUM 2x6 NO. 3 SOUTHERN PINE LUMBER (MIN) MOUNTED DIRECTLY TO SUPPORT STRUCTURE.
8. DESIGN OF THE SUPPORT STRUCTURE SHALL BE THE SOLE RESPONSIBILITY OF THE BUILDING DESIGNER AND SHALL BE DESIGNED FOR THE LOADS LISTED IN NOTE 5.
9. SCREW ANCHORS OR LAG SCREWS SHALL BE INSTALLED PER MANUFACTURER'S WRITTEN INSTRUCTIONS.

MAX SPACING OF ANCHORS/SCREWS PER JAMB (IN)		
3/8" SIMPSON TITEN HD SCREW ANCHOR TO MINIMUM 2000 PSI CONCRETE <sup>NOTE 1</sup>	3/8" SIMPSON TITEN HD SCREW ANCHOR TO MINIMUM 2000 PSI GROUT FILLED CMU <sup>NOTE 2</sup>	3/8" X 3" LONG LAG SCREW <sup>NOTE 3</sup>
24	12	24

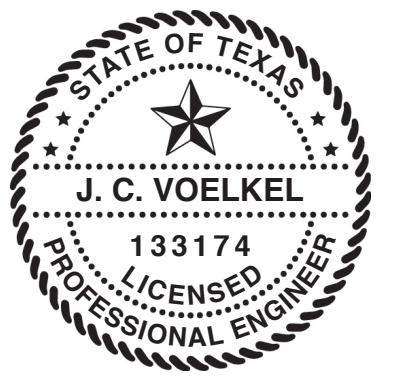
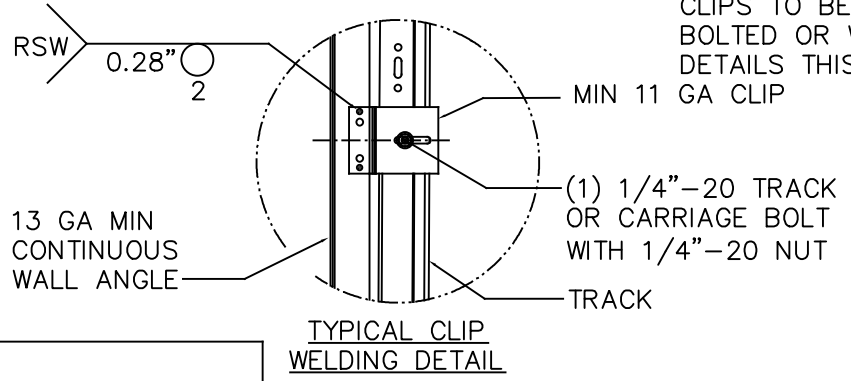

J. CHRISTIAN VOELKEL, PE  
 312 N. NEW WARRINGTON ROAD, UNIT 1A  
 PENSACOLA, FL  
 FL PE 82229  
 TX PE 133174

DOOR WIDTH UP TO	IMPACT RESISTANT	END STILE QTY	ANGLE/SECT		STRUT AT TOP	ROLLER			TRACK		HARDWARE
			QTY	TYPE		TYPE	TIRE DIA.	STEM DIA.	BRKT/FSTNR MAX SPACING	VERTICAL GAGE	
16'-2"	YES	DOUBLE	1	3 X 2 X 3/16	HS-3	TR-3	2"	7/16" 1144	12"	0.085"	STANDARD

THE DRAWINGS AND ALL OTHER INFORMATION CONTAINED HEREIN ARE THE CONFIDENTIAL AND PROPRIETARY PROPERTY OF OVERHEAD DOOR CORPORATION AND ITS AFFILIATED COMPANIES. THIS DRAWING AND INFORMATION, IN WHOLE OR IN PART, MAY NOT BE COPIED IN ANY MANNER OR DISCLOSED TO ANYONE WITHOUT THE PRIOR WRITTEN CONSENT OF OVERHEAD DOOR CORPORATION. NO DISCLOSURE OF ANY OF THIS DRAWING OR INFORMATION IS INTENDED TO OPERATE AS A LICENSE OR AUTHORIZATION TO USE IT FOR ANY PURPOSE WITHOUT THE SPECIFIC WRITTEN CONSENT OF OVERHEAD DOOR CORPORATION.

ASME Y14.100 AND Y14.5 APPLY, UNLESS OTHERWISE SPECIFIED DIMENSIONS ARE IN U.S. CUSTOMARY UNITS.	TOLERANCES UNLESS OTHERWISE SPECIFIED	FINISH	NAME	DATE	DRAWING TITLE:
WHOLE NUMBERS: ±.25	N/A	N/A	DRAWN BY:	10/2/20	WINDLOAD, 521, 9920
.X ±.1			CHECKED BY:	10/2/20	48/-54 PSF, 16'-2" MAX
.XX ±.03			APPROVED BY:	10/6/20	DRAWING NUMBER
.XXX ±.010					D-411368
ANGLES: ±.5°					SCALE: N/A
HOLES: ±					SHEET 2 OF 2