

Top Fixture Attachment

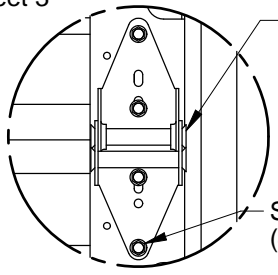

Edge Hinge Attachment

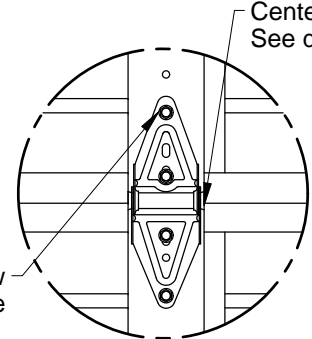

Center Hinge Attachment

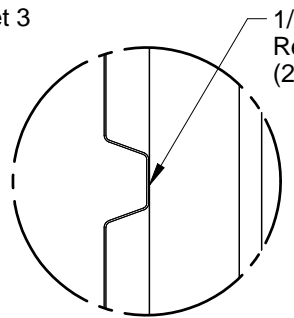

Rib Detail

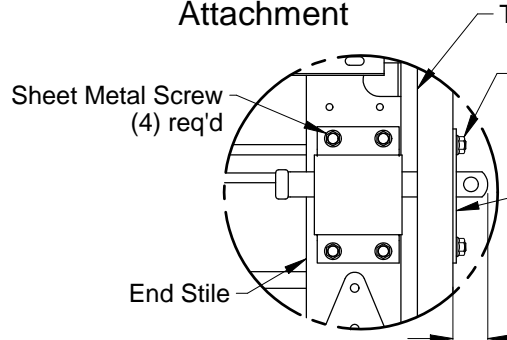

Optional Interior Lock Attachment

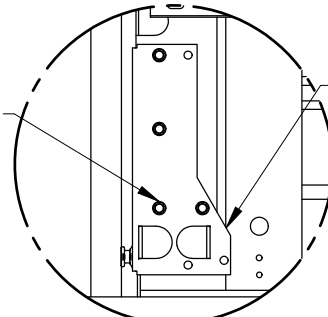

Corner Bracket Attachment

Doors tested per ANSI/DASMA 108 for static air pressure

Maximum Door Width	Stiles per Sect	Ctr Hngs per Sect	Design Loads	
8'-2"	1	1	47.2	-53.4
9'-2"	1	1	42.1	-47.6
10'-2"	2	2	34.2	-38.7
12'-2"	2	2	29.2	-32.8
14'-2"	3	3	25.1	-28.2
16'-2"	3	3	22.0	-24.7
18'-2"	4	4	23.2	-30.7
20'-2"	4	4	18.8	-24.9

Steel Section
 S24C .017 thick G-40 galvanized steel
 S24 .023 thick G-60 galvanized steel
 S20 .035 thick G-90 galvanized steel with an epoxy primer and baked on polyester finish which is roll-formed with a smooth texture.

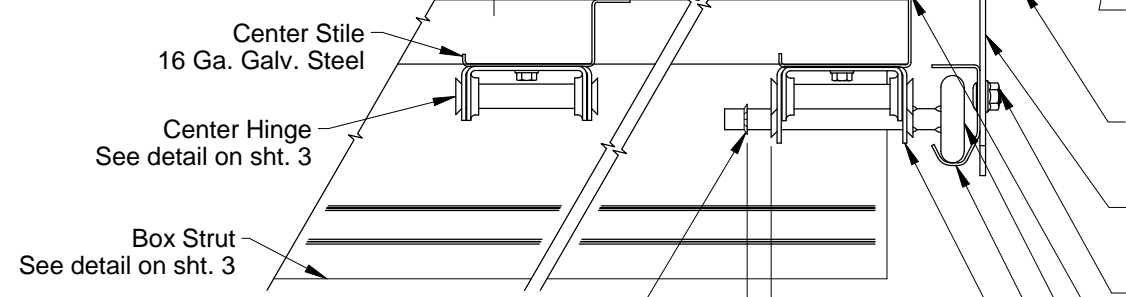

Section B-B

- Jambs
2x6 #2 Douglas Fir or better wood jamb. See sht. 2 for attachment
- Hex Head Lag Screw (2) per bracket. See detail on sht. 3
- Track Bracket shown See detail on sht. 3
- Full Angle optional
- Track Bolt / Whiz Lock Nut See detail on sht. 3
- End stile
16 Ga. Galv. Steel
- Track Roller See detail on sht. 3
- Track, 2" shown, 3" optional See detail on sht. 3
- Edge Hinge See detail on sht. 3

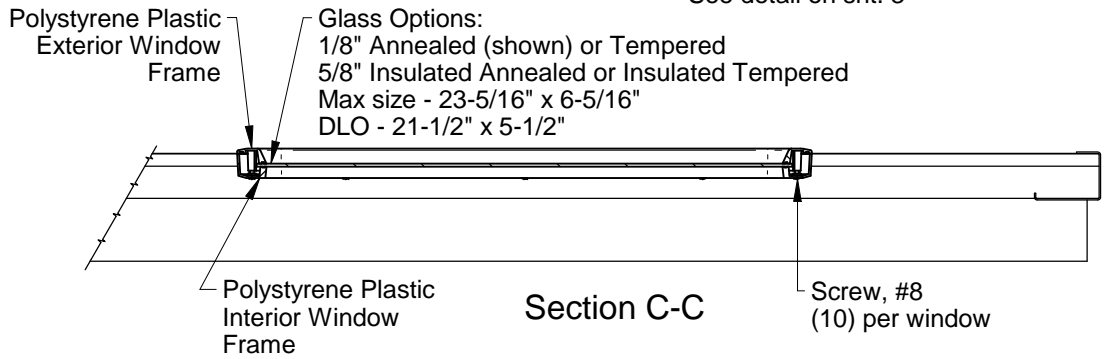

Section C-C

Glass Options:
 1/8" Annealed (shown) or Tempered
 5/8" Insulated Annealed or Insulated Tempered
 Max size - 23-5/16" x 6-5/16"
 DLO - 21-1/2" x 5-1/2"

Spring Counterbalance
 Spring wire individually calculated to counterbalance door. Quantity and size of spring will vary based on door size.

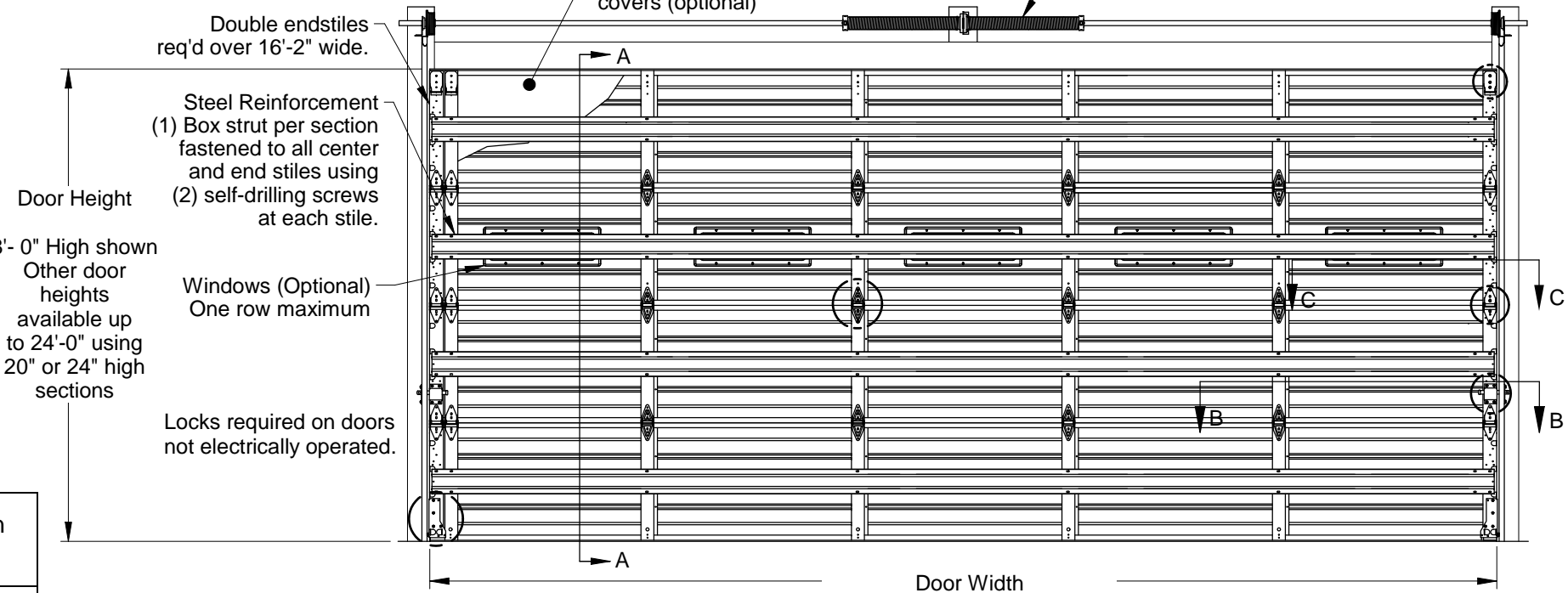

Interior Elevation

Door Height
 8'-0" High shown
 Other door heights available up to 24'-0" using 20" or 24" high sections

Windows (Optional)
 One row maximum

Locks required on doors not electrically operated.

Door Width
 See chart for other door widths (18'-2" shown)

John E. Scates
 2560 King Arthur Blvd, Ste 124-54
 Lewisville, TX 75056
 FL PE #51737
 TX PE #56308-f2203

Rev.	Description	ECO	Date	ECO: 7679.01
B	Removed vent option, acrylic & polycarb. glass on sht 1.	7679.03	12/09/19	
A	New release for production.	7679.01	02/05/19	

Scale: None
 Drawn by: R. Frey
 Checked by: G. Wedekind
 Date: 02/05/19

RAYNOR
 1101 East River Road
 Dixon, IL 61021

Title: Spec, Wind Load SteelForm - S24C, S24, S20

No. **P-2820** Sheet 1 of 3 Rev **B**

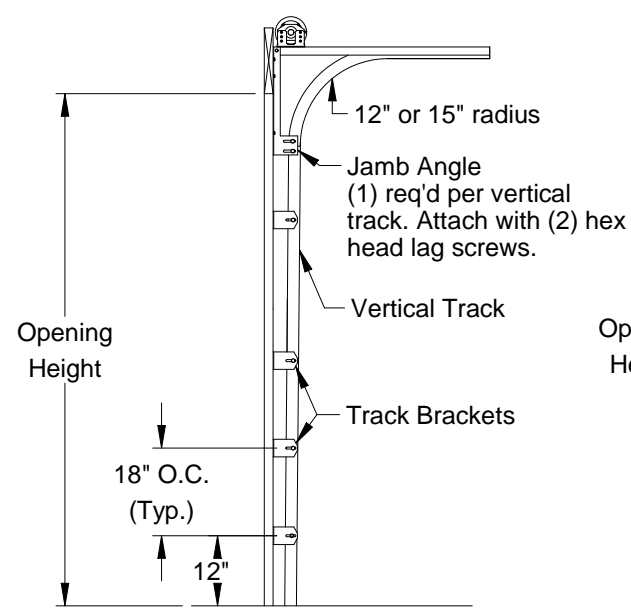

**Typical Track Installation
Bracket Mount
Wood Jamb**

Normal headroom track shown, low headroom, lift clearance and vertical lift track available

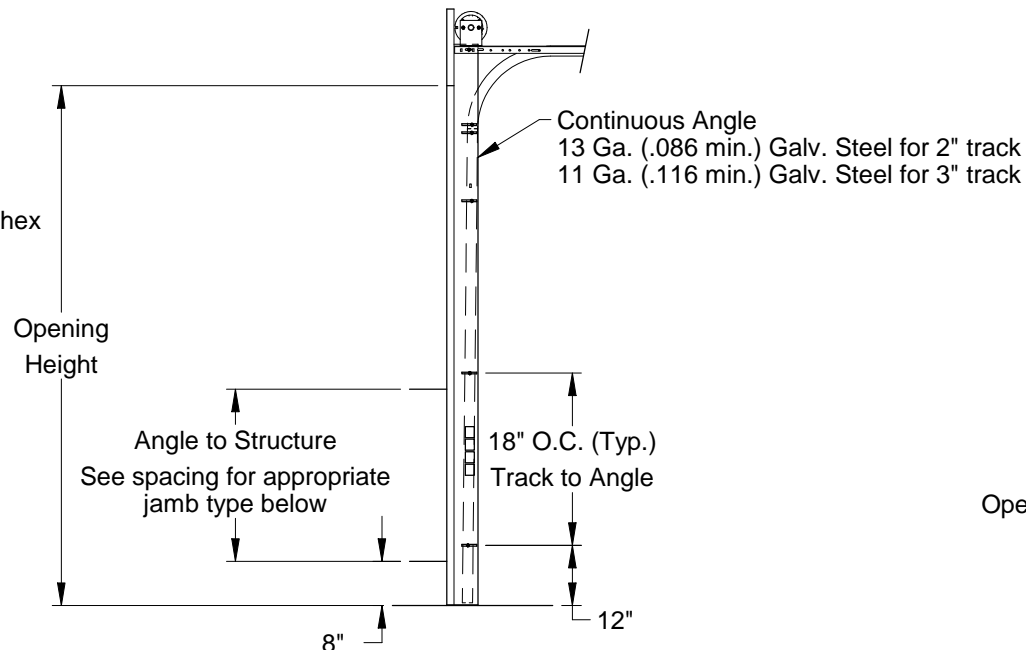

**Typical Track Installation
Angle Mount
Wood, Steel or Concrete Jamb**

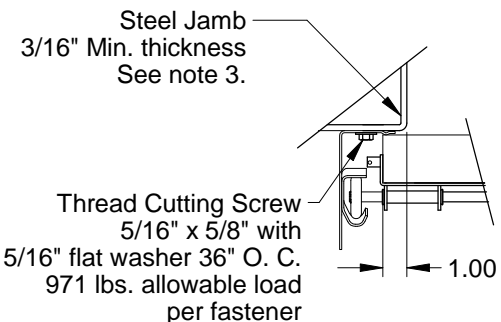
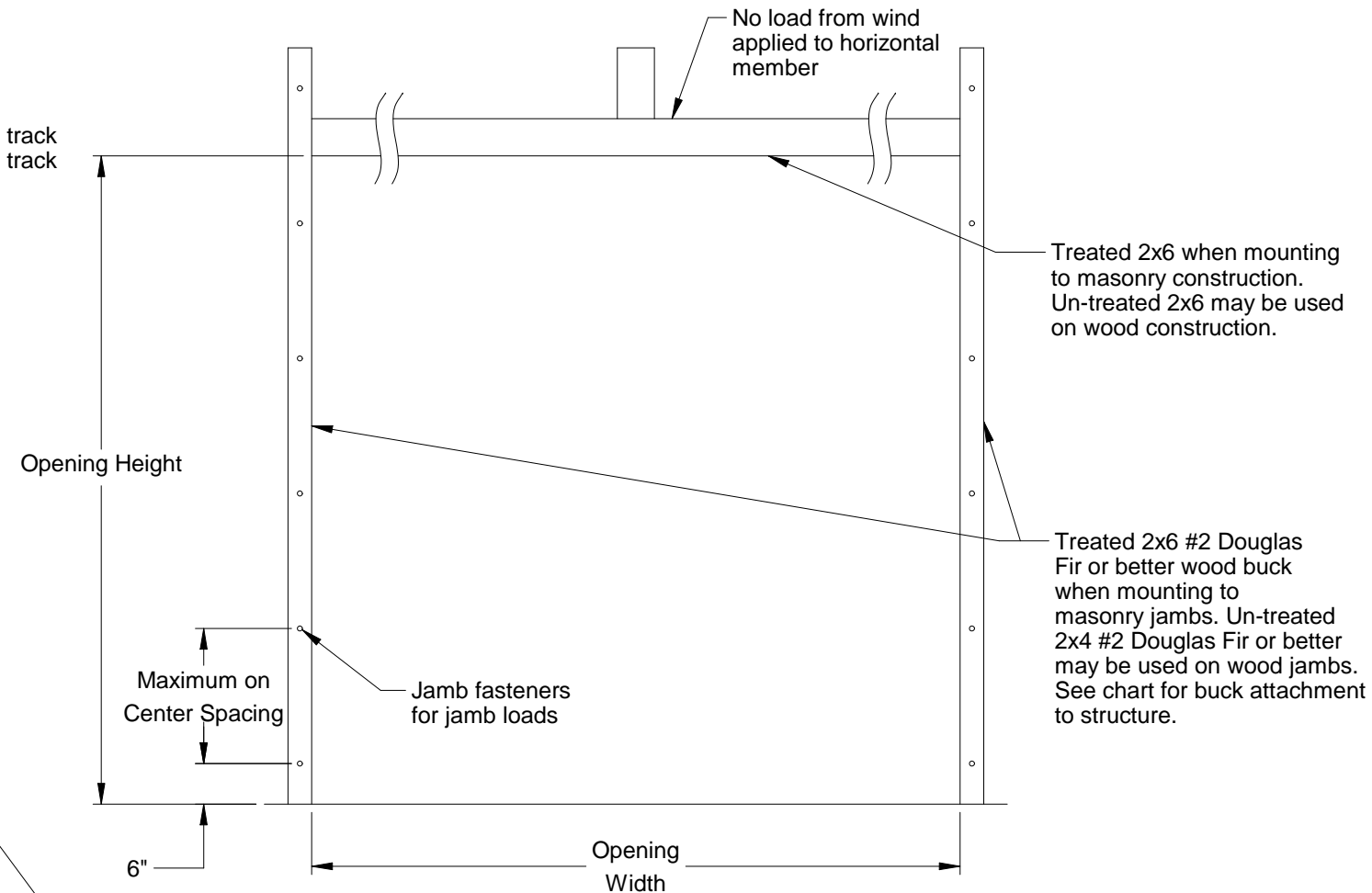

**Track Assembly Attachment
to Steel Jamb**
2" Track Angle Mount Turned-in (shown)
3" Track Angle Mount Available

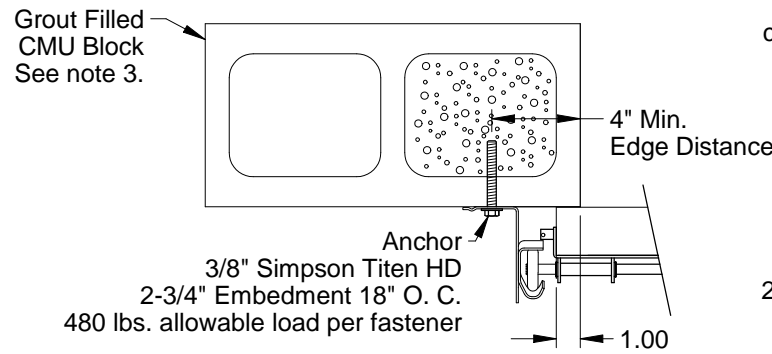

**Track Assembly Attachment
to Grout Filled CMU Block**
2" Track Angle Mount Turned-out (shown)
3" Track Angle Mount Available

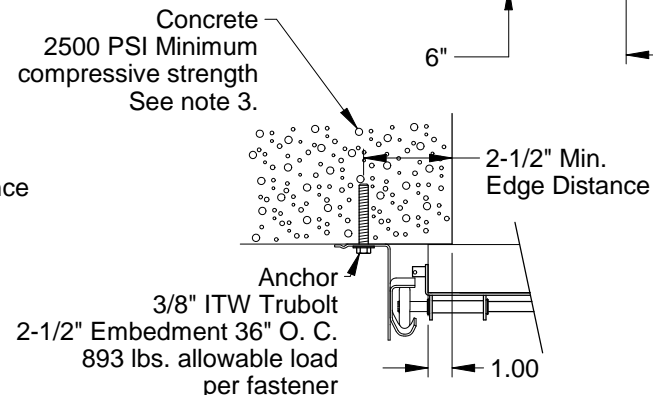

**Track Assembly Attachment
to 2500 PSI Min. Concrete**
2" Track Angle Mount Turned-out (shown)
3" Track Angle Mount Available

Jamb Attachment Notes:

1. Maximum Positive Load per Jamb = (18'-2" x 23.2 PSF) / 2 = 211 lbs. per foot.
2. Maximum Negative Load per Jamb = (18'-2" x -30.7 PSF) / 2 = 279 lbs. per foot.
3. Design of the supporting structure shall be the sole responsibility of the building designer and shall be designed for the jamb loads listed in notes 1 and 2.
4. Alternate jamb attachments may be used if approved by a registered Professional Engineer.
5. DASMA Technical Data Sheet TDS-161 may be used for alternate jamb attachments.
6. 3/8" diameter lag screws required 1/16" pilot hole and 1-1/2" minimum required distance.

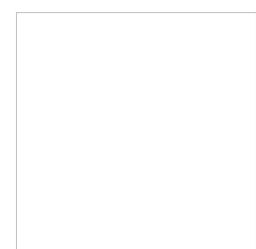

John E. Scates
2560 King Arthur Blvd, Ste 124-54
Lewisville, TX 75056
FL PE #51737
TX PE #56308-f2203

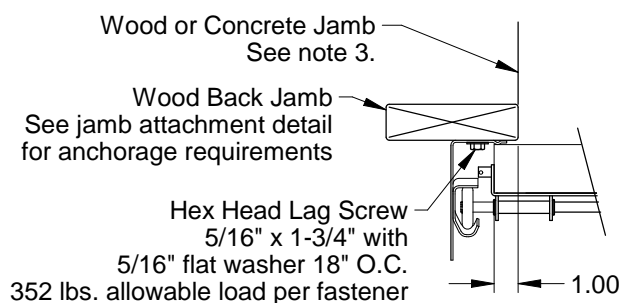

**Track Assembly Attachment
to Wood Back Jamb**
2" Track Angle Mount Turned-in (shown)
3" Track Angle Mount Available

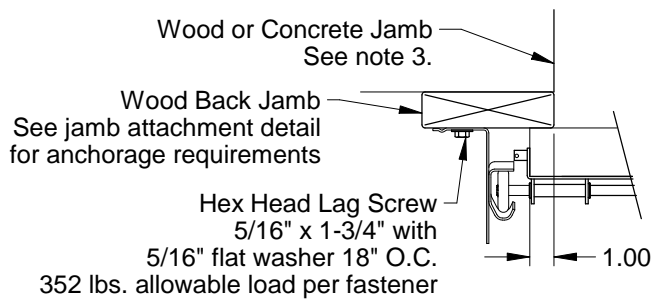

**Track Assembly Attachment
to Wood Back Jamb**
2" Track Angle Mount Turned-out (shown)
3" Track Angle Mount Available

2x6 Attachment to Structure						
Structure Type	Fastener Type	Minimum Embedment	Minimum Edge Distance	Minimum on Center Spacing	Maximum on Center Spacing	Allowable Tension Load
2500 PSI Min. Concrete	1/4" Tapcon+ (Plus) with 1-1/8" OD Washer	2"	2.5"	6"	24"	526
Southern Pine	3/8" x 3" Lag with 1-1/8" OD Washer	1.50"	1.50"	1.50"	24"	655
Spruce Pine Fir	3/8" x 3" LAG with 1-1/8" OD Washer	1.50"	1.50"	1.50"	24"	482

Scale: None
Drawn by: R. Frey
Checked by: G. Wedekind
Date: 02/05/19
ECO: 7679.01



Title: Spec, Wind Load SteelForm - S24C, S24, S20	
No. P-2820	Sheet 2
Rev B	

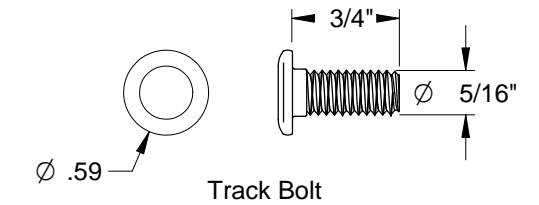
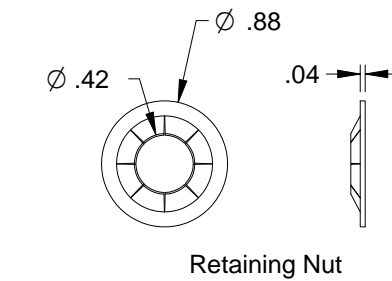
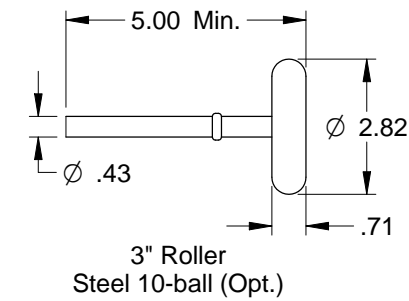
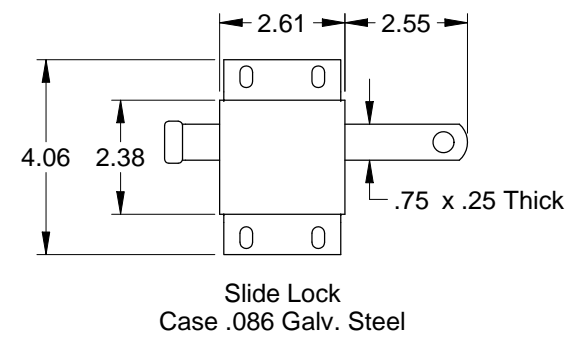
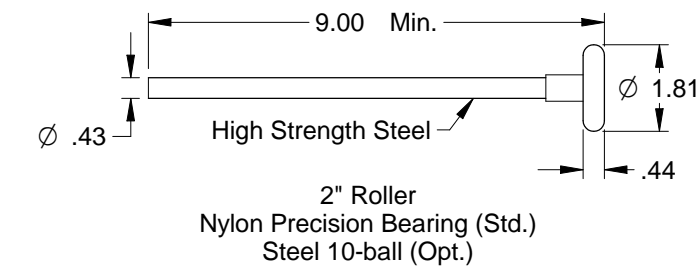
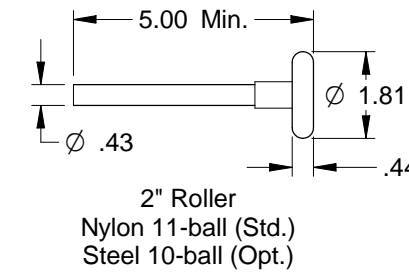
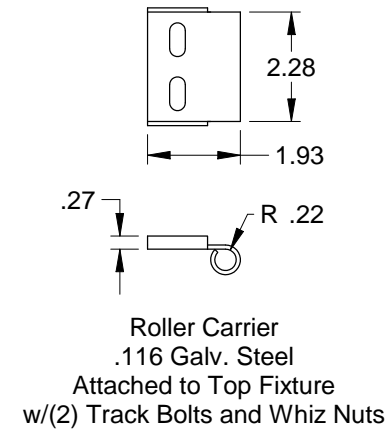
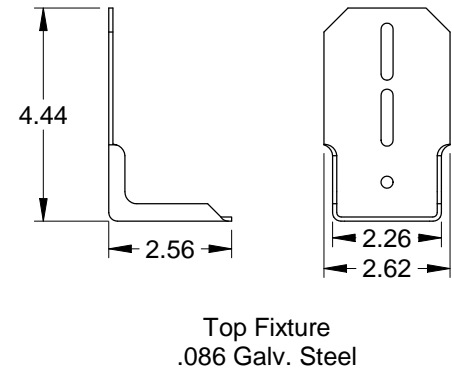
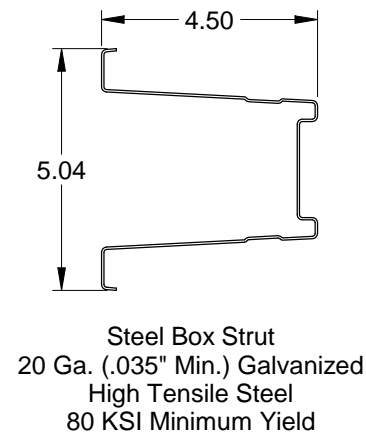
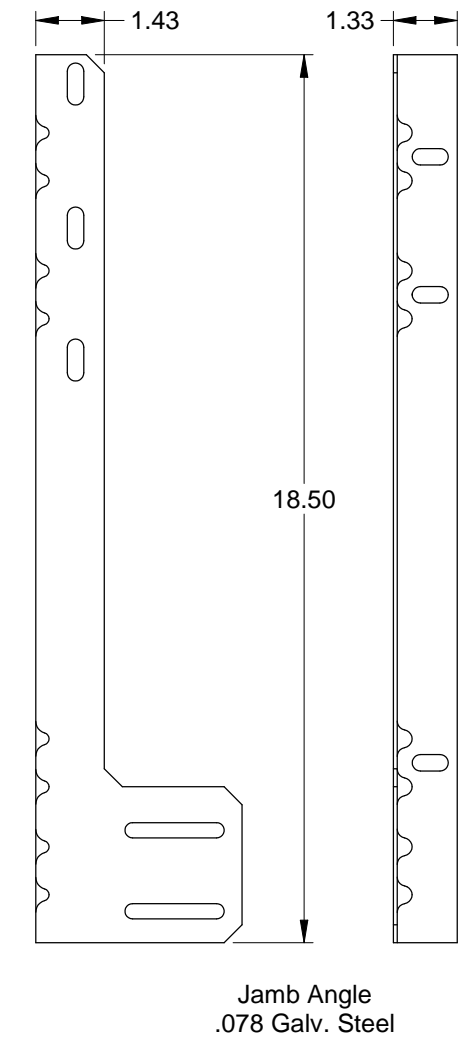
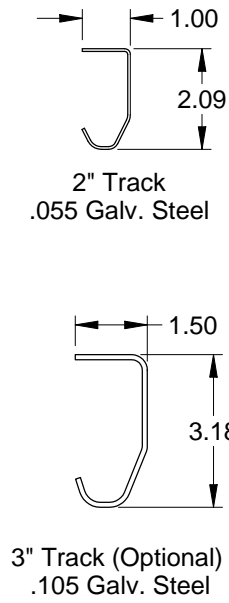
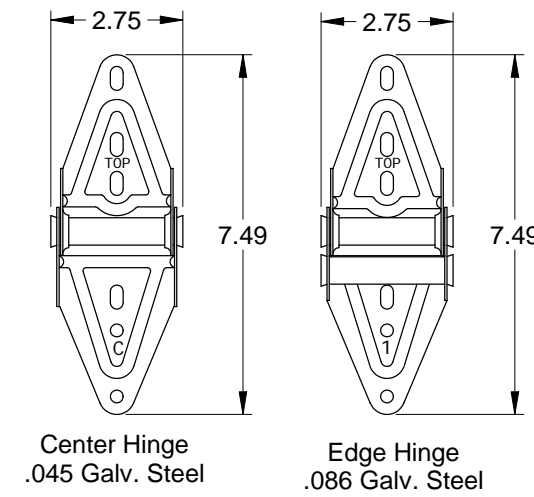
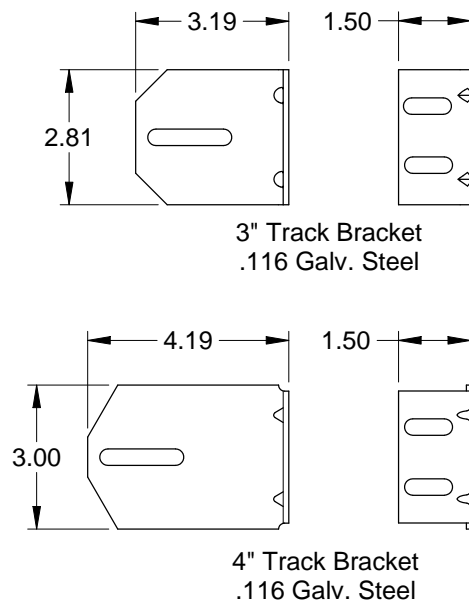
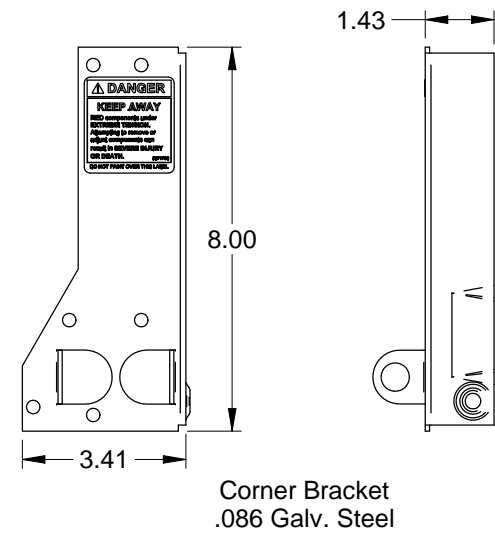

John E. Scates
2560 King Arthur Blvd, Ste 124-54
Lewisville, TX 75056
FL PE #51737
TX PE #56308-f2203

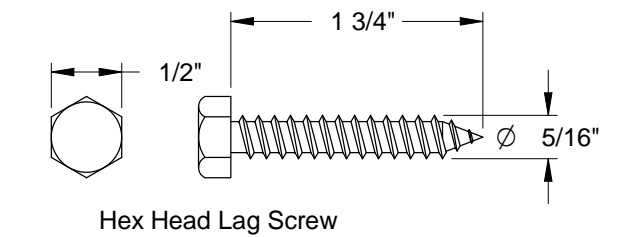
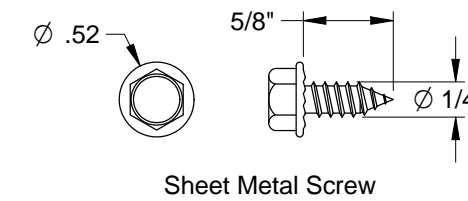
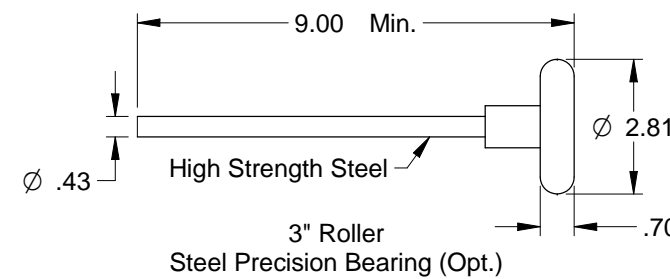

Scale: None
Drawn by: R. Frey
Checked by: G. Wedekind
Date: 02/05/19
ECO: 7679.01



Title: Spec, Wind Load SteelForm - S24C, S24, S20		
No. P-2820	Sheet 3	Rev B