

Doors tested per ANSI/DASMA 108 for static air pressure

Maximum Door Width	Stiles per Sect	Ctr Hngs per Sect	Design Loads	
8'-2"	1	1	22.4	-26.4
9'-2"	1	1	20.0	-23.5

John E. Scates
 2560 King Arthur Blvd, Ste 124-54
 Lewisville, TX 75056
 FL PE #51737
 TX PE #56308-f2203

Professional Engineer's seal provided only for verification of wind load construction details

Rev.	Description	ECO	Date	ECO: 7679.01
B	Removed vent option, acrylic & polycarb. glass on sht 1.	7679.03	12/09/19	
A	New release for production.	7679.01	02/05/19	

Scale: None

Drawn by: R. Frey

Checked by: G. Wedekind

Date: 02/05/19

ECO: 7679.01

RAYNOR

1101 East River Road
 Dixon, IL 61021

Title: Spec, Wind Load SteelForm - S24C, S24, S20

No. **P-2818**

Sheet 1 of 3

Rev **B**

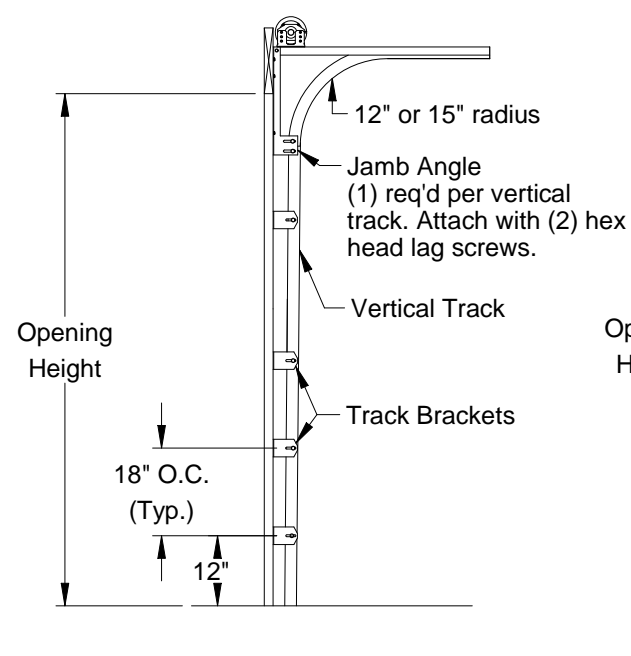

**Typical Track Installation
Bracket Mount
Wood Jamb**

Normal headroom track shown, low headroom, lift clearance and vertical lift track available

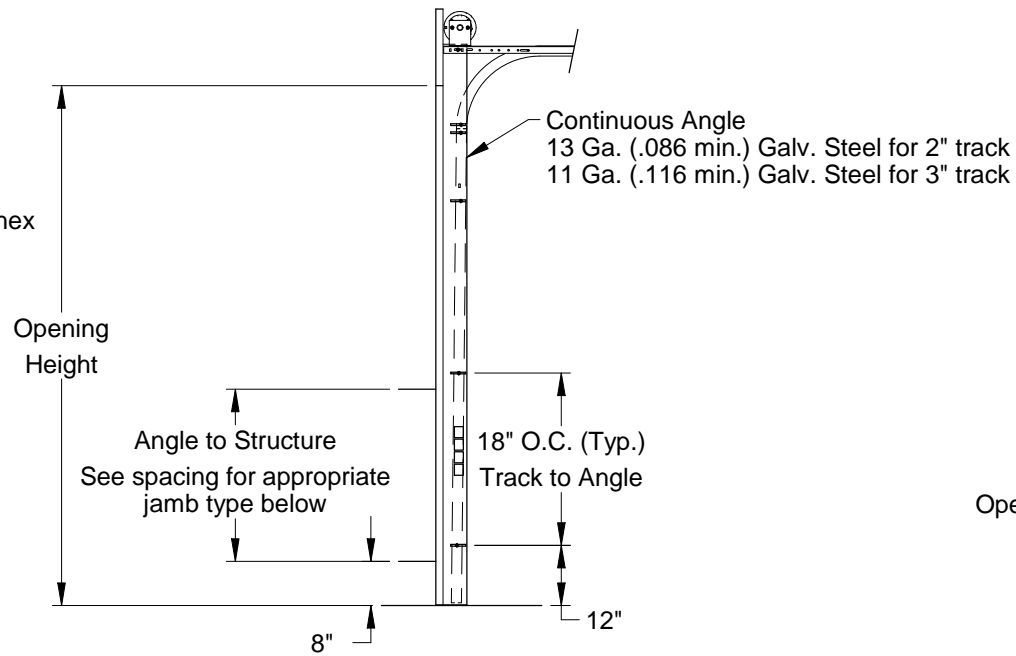

**Typical Track Installation
Angle Mount
Wood, Steel or Concrete Jamb**

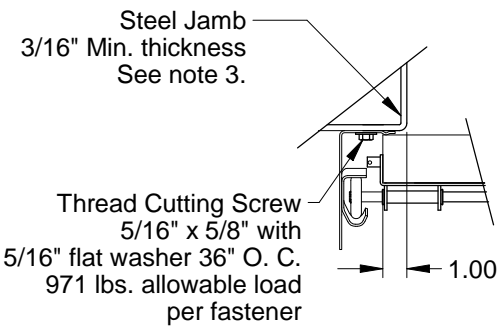
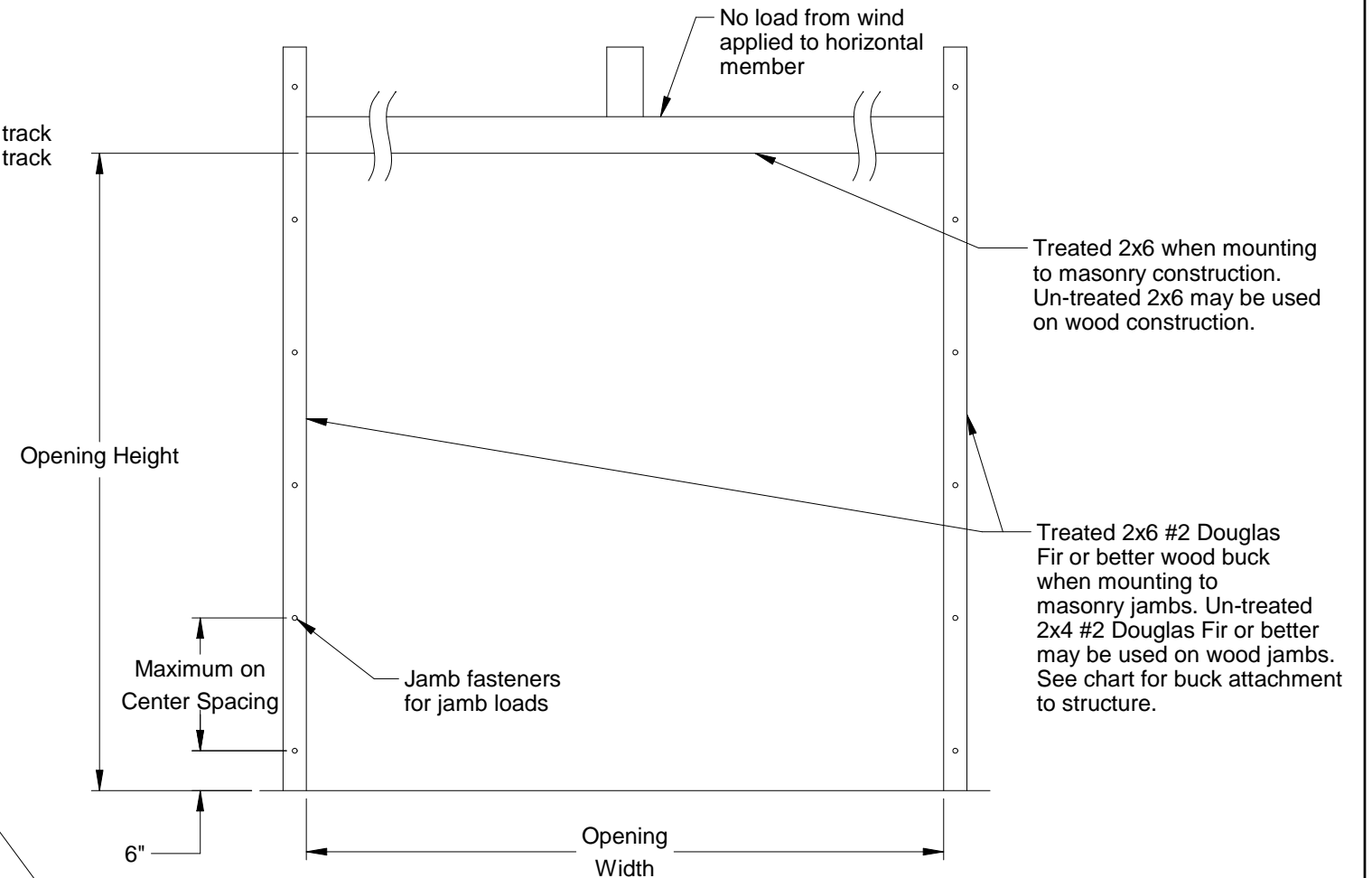

**Track Assembly Attachment
to Steel Jamb**

2" Track Angle Mount Turned-in (shown)
3" Track Angle Mount Available

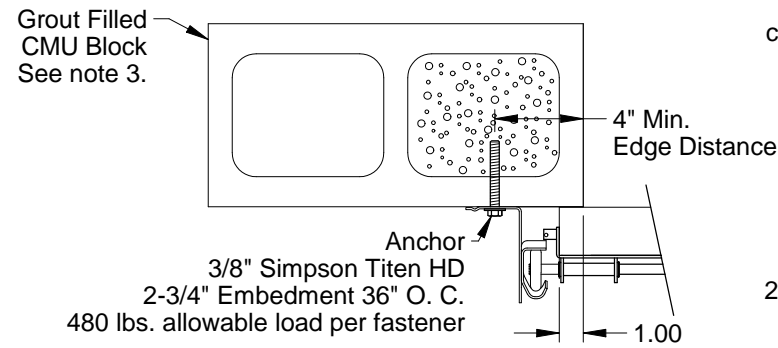

**Track Assembly Attachment
to Grout Filled CMU Block**

2" Track Angle Mount Turned-out (shown)
3" Track Angle Mount Available

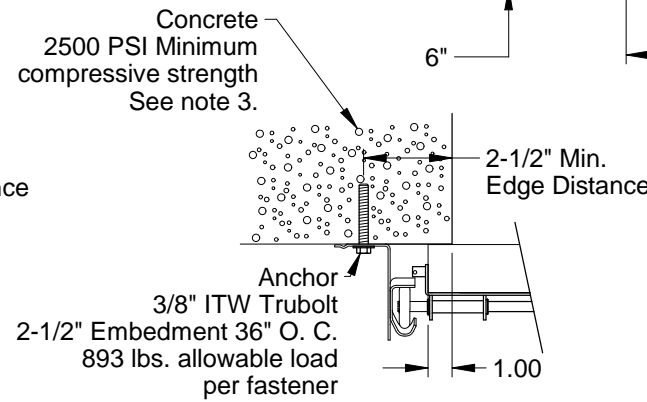

**Track Assembly Attachment
to 2500 PSI Min. Concrete**

2" Track Angle Mount Turned-out (shown)
3" Track Angle Mount Available

Jamb Attachment Notes:

1. Maximum Positive Load per Jamb = (8'-2" x 22.6 PSF) / 2 = 93 lbs. per foot.
2. Maximum Negative Load per Jamb = (8'-2" x -27.0 PSF) / 2 = 111 lbs. per foot.
3. Design of the supporting structure shall be the sole responsibility of the building designer and shall be designed for the jamb loads listed in notes 1 and 2.
4. Alternate jamb attachments may be used if approved by a registered Professional Engineer.
5. DASMA Technical Data Sheet TDS-161 may be used for alternate jamb attachments.
6. 3/8" diameter lag screws required 1/16" pilot hole and 1-1/2" minimum required distance.



John E. Scates
2560 King Arthur Blvd, Ste 124-54
Lewisville, TX 75056
FL PE #51737
TX PE #56308-f2203

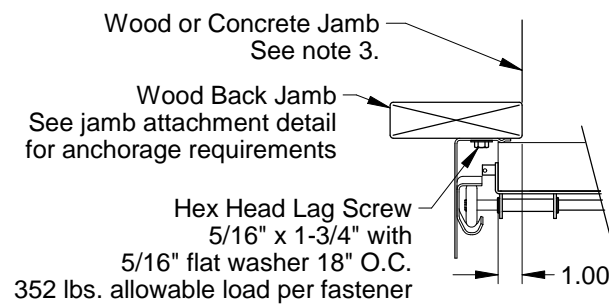

**Track Assembly Attachment
to Wood Back Jamb**

2" Track Angle Mount Turned-in (shown)
3" Track Angle Mount Available

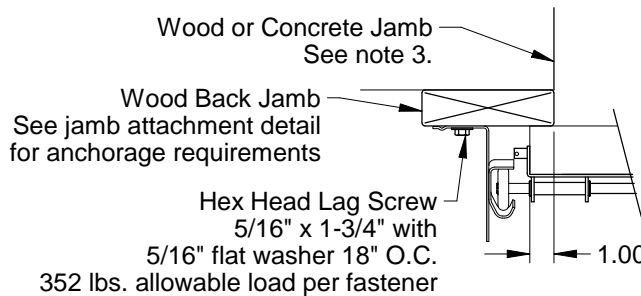

**Track Assembly Attachment
to Wood Back Jamb**

2" Track Angle Mount Turned-out (shown)
3" Track Angle Mount Available

2x6 Attachment to Structure						
Structure Type	Fastener Type	Minimum Embedment	Minimum Edge Distance	Minimum on Center Spacing	Maximum on Center Spacing	Allowable Tension Load
2500 PSI Min. Concrete	1/4" Tapcon+ (Plus) with 1-1/8" OD Washer	2"	2.5"	6"	24"	526
Southern Pine	3/8" x 3" Lag with 1-1/8" OD Washer	1.50"	1.50"	1.50"	24"	655
Spruce Pine Fir	3/8" x 3" LAG with 1-1/8" OD Washer	1.50"	1.50"	1.50"	24"	482

Scale: None
Drawn by: R. Frey
Checked by: G. Wedekind
Date: 02/05/19
ECO: 7679.01



1101 East River Road
Dixon, IL 61021

Title: Spec, Wind Load SteelForm - S24C, S24, S20		
No. P-2818	Sheet 2	Rev B

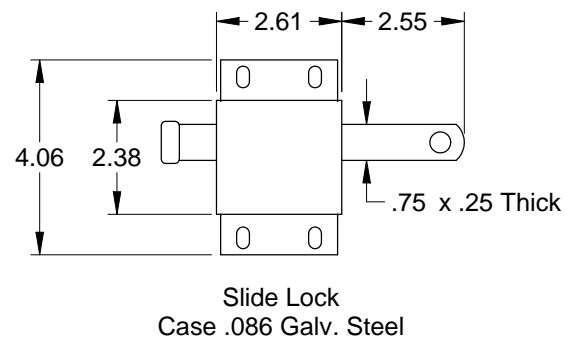
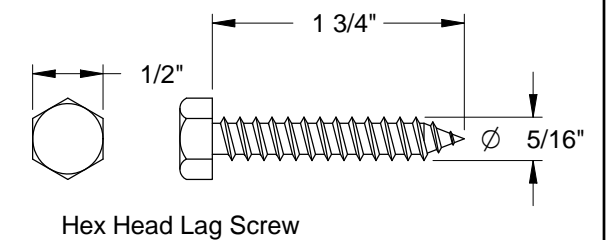
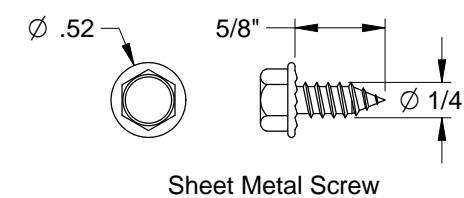
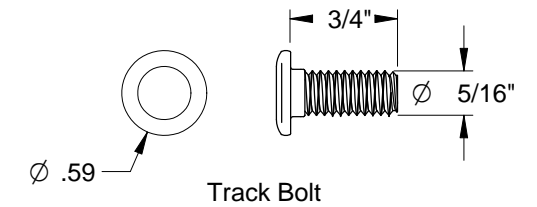
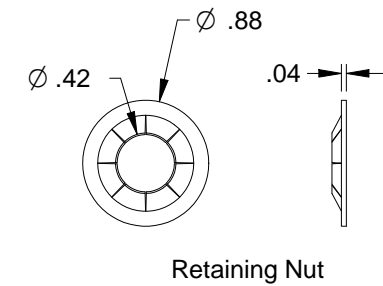
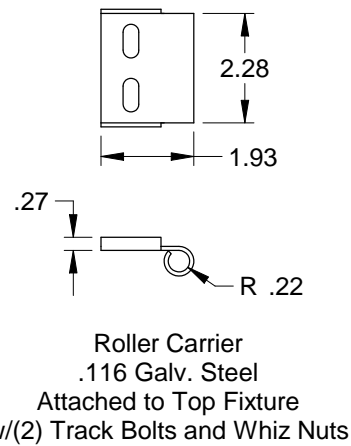
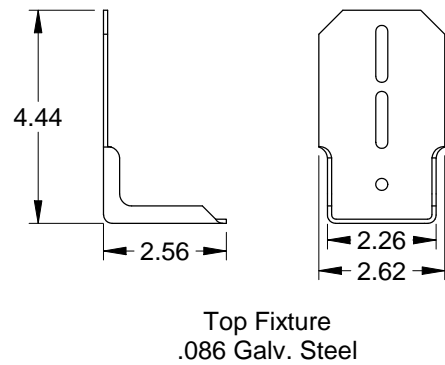
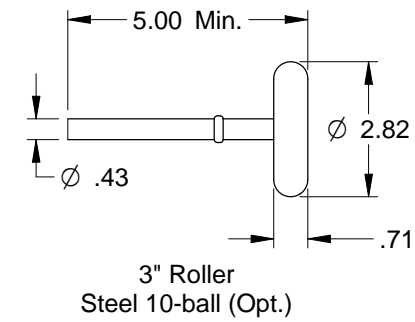
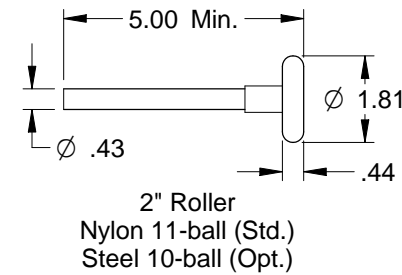
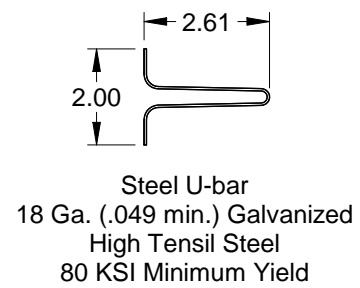
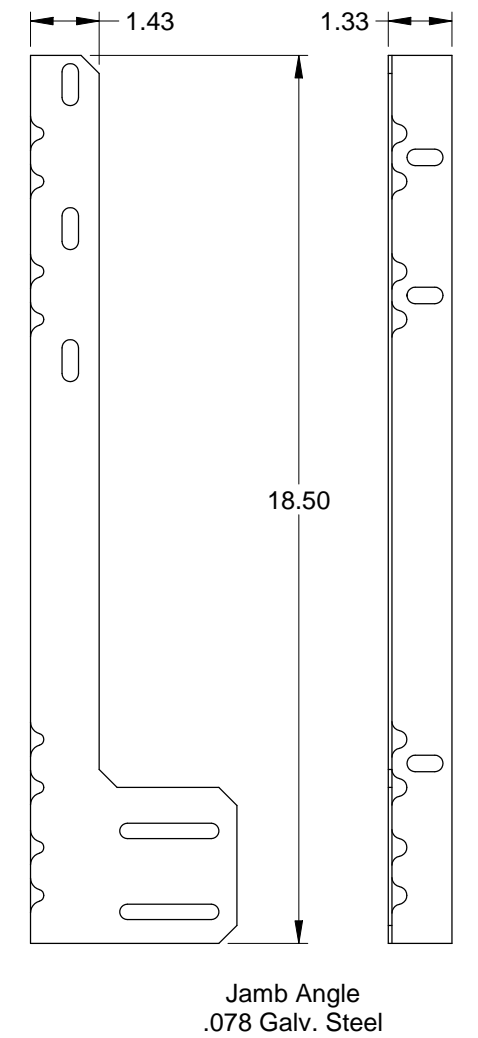
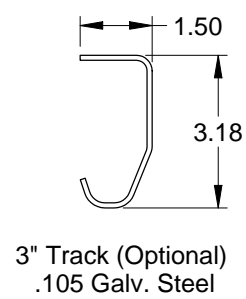
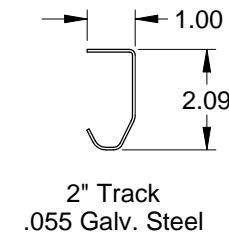
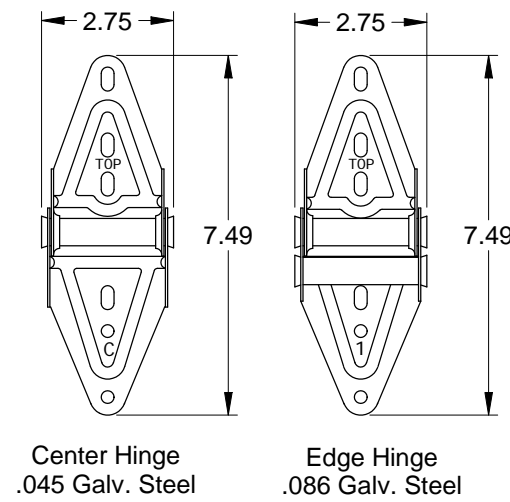
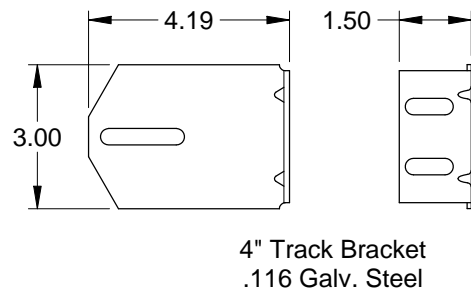
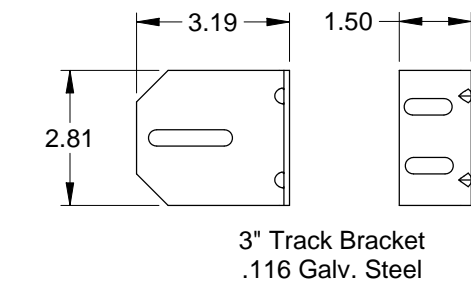
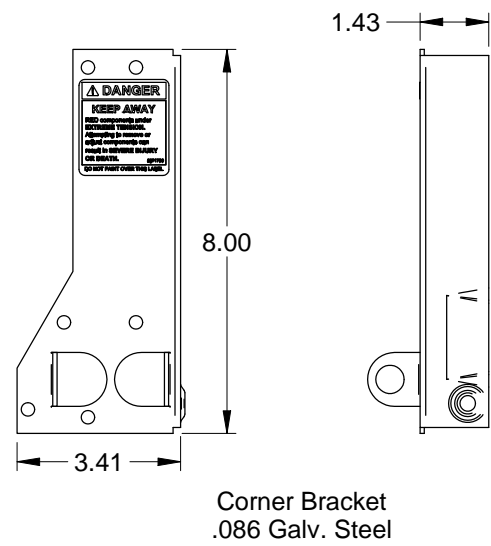

John E. Scates
2560 King Arthur Blvd, Ste 124-54
Lewisville, TX 75056
FL PE #51737
TX PE #56308-f2203

Scale: None
Drawn by: R. Frey
Checked by: G. Wedekind
Date: 02/05/19
ECO: 7679.01



Title: Spec, Wind Load SteelForm - S24C, S24, S20		
No. P-2818	Sheet 3	Rev B