

MODELS	27 GA SHORT	27 GA FLUSH	27 GA LONG
CLOPAY	4300, HDG	4301, HDGF	4310, HDGL
HOLMES	66, 66G, 6200	68, 6201	67, 67G, 6203
IDEAL	SP200	SF200	SE200

SHEET  
1 OF 3

REVISIONS					DESCRIPTION
REV. NO.	ZONE	DATE	ECN NO.	APPVD:	
05	-	11/25/20	-	SH	UPDATED TITLE BLOCK AND ADDED COMPLIANCE STATEMENT.

(1) 20 GA. BACKER PLATE BETWEEN EACH EMBOSS LOCATION THAT CONTAINS A CENTER HINGE. ATTACHED WITH DOUBLE SIDED ACRYLIC ADHESIVE TO BACK OF DOOR.

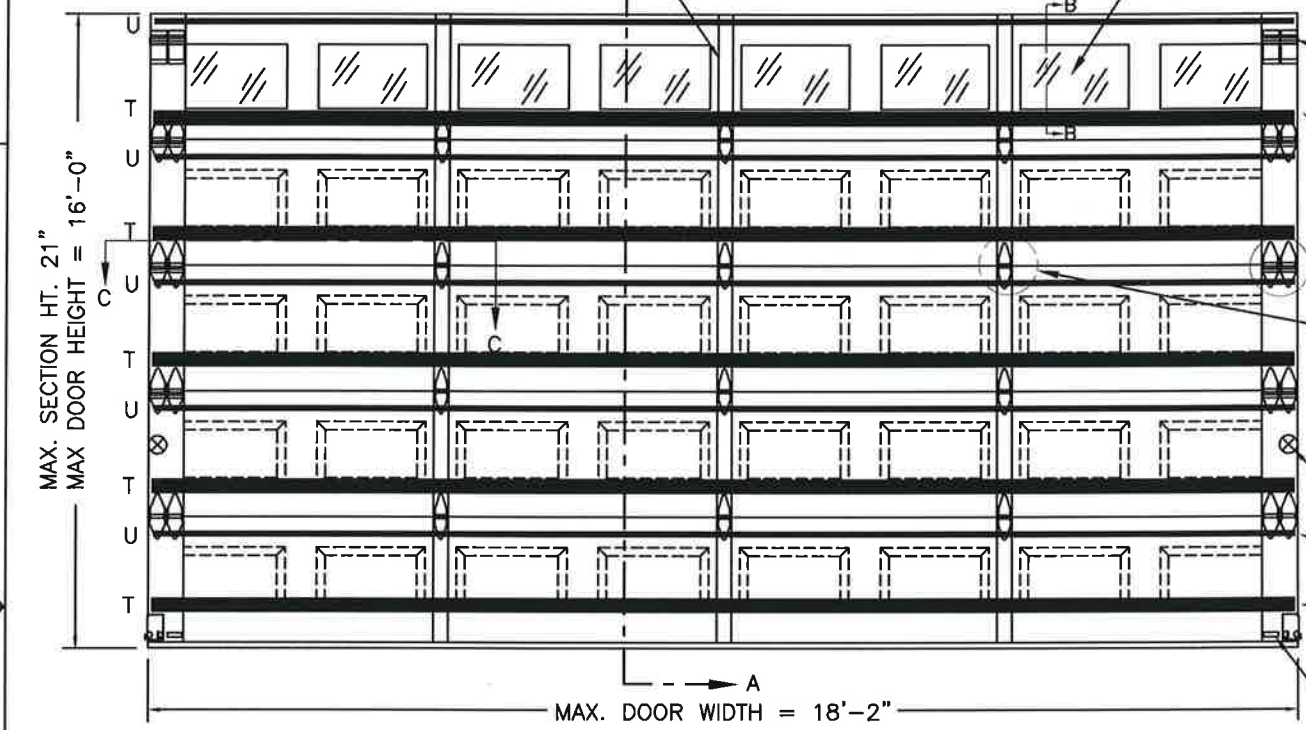

OPTIONAL ROW OF IMPACT-RESISTANT GLAZING. MAX. GLAZING SIZE IS 19-1/2" x 12". GLAZING IS INJECTION MOLDED GE LEXAN SLX2432T, AN APPROVED CC2 PLASTIC IN ACCORDANCE WITH IBC/FBC 2606. SEE SECTION B-B FOR ASSEMBLY DETAILS. (GLAZING SHOWN IN INTERMEDIATE SECTION.)

**IMPACT-RESISTANT CONSTRUCTION:**  
SOLID DOORS (NO GLAZING) OR DOORS WITH OPTIONAL IMPACT-RESISTANT GLAZING ARE IMPACT-RESISTANT. OPTIONAL MAX WINDOW SIZE 19-1/2"x12" INJECTION-MOLDED POLYCARBONATE FRONT FRAME AND GLAZING IS GE LEXAN SLX2432T, AN APPROVED CC2 PLASTIC IN ACCORDANCE WITH IBC/FBC 2606. THE ENTIRE DOOR ASSEMBLY INSTALLED IN COMPLIANCE WITH THIS SECTION MEETS THE WIND LOAD REQUIREMENTS OF THE FLORIDA BUILDING CODE AND INTERNATIONAL BUILDING CODE AND IS LARGE- AND SMALL-MISSILE IMPACT RESISTANT.

STRUT AND TOP BRACKET ARRANGEMENT WITH STANDARD ENDSTILE AND TOP SECTION SOLID OR GLAZED (SHOWN).  
16 GA. DOUBLE END STILES. MAY BE NOTCHED FOR LITES.

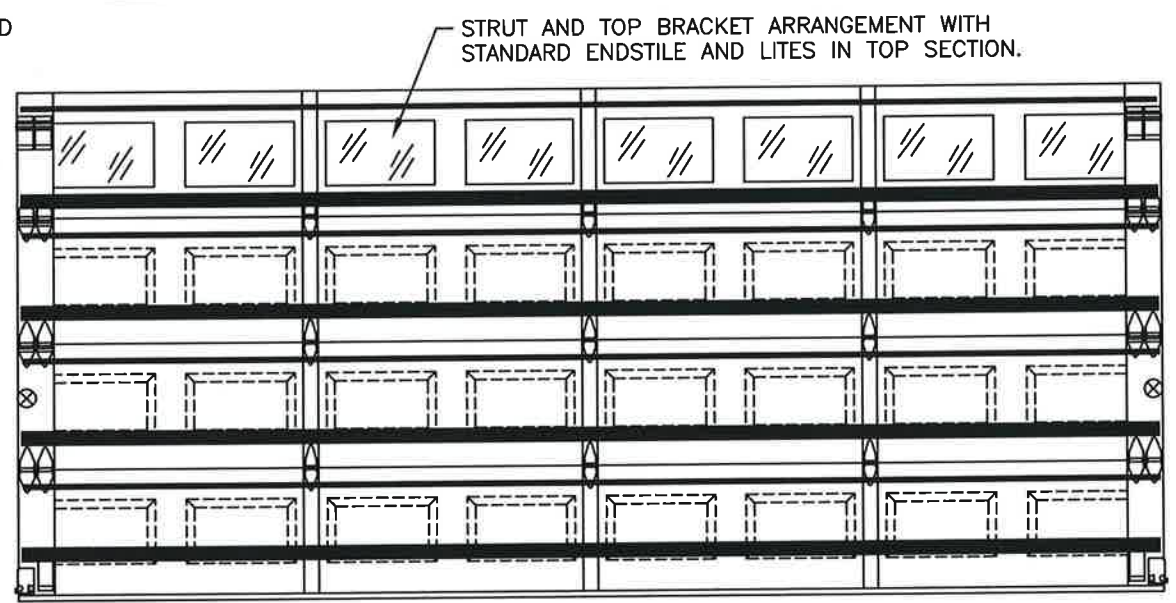

VIEW "B" (SEE SHEET TWO).  
VIEW "C" (SEE SHEET TWO).

TWO POINT LOCKING INTO TRACK.  
U-BAR.

(1) 3-IN ROLLER CARRIER (P/N 0120394) USED WITH 3" TRACK. ATTACH WITH (3) 1/4"x3/4" SELF TAPPING SCREWS.

DOOR HEIGHT	# OF SECTIONS
UP TO 7'0"	4
7'3" TO 8'9"	5
9'0" TO 10'6"	6
10'9" TO 12'3"	7
12'6" TO 14'0"	8
14'3" TO 15'9"	9
16'0"	10
MAX SECTION HEIGHT: 21"	

**SECTION B-B (IMPACT-RESISTANT GLAZING OPTION)**

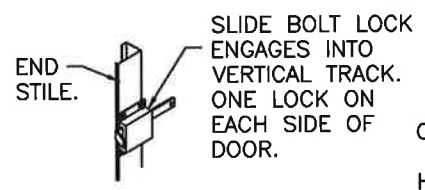
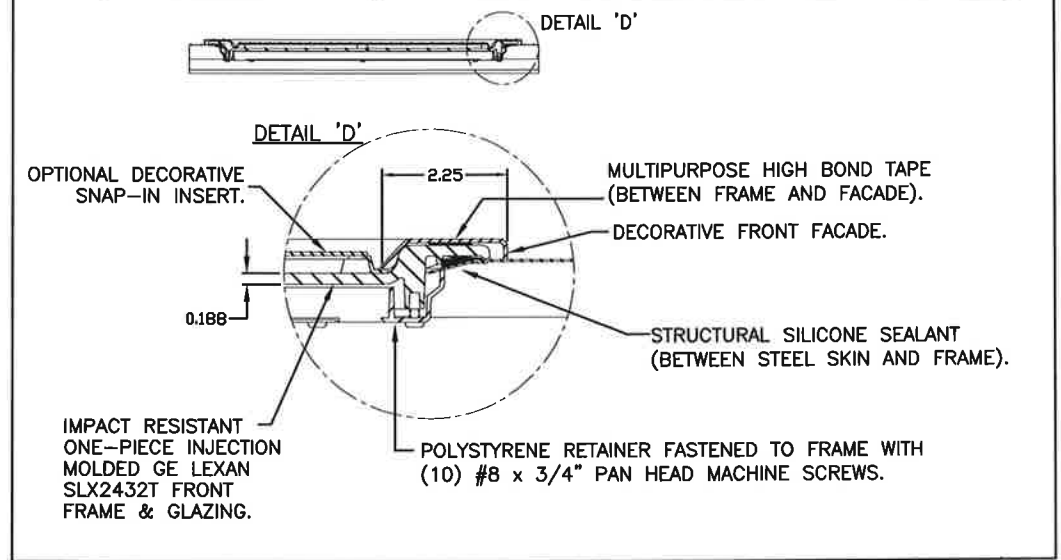

INSIDE SLIDE BOLT LOCK OPTION.

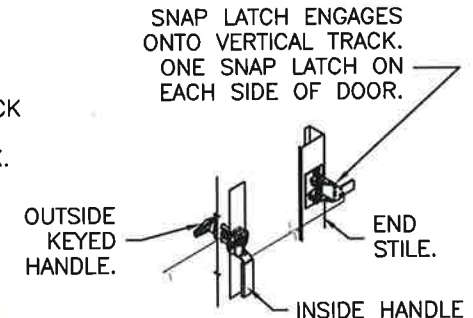

OUTSIDE KEYED LOCK WITH SNAP LATCH LOCK OPTION.

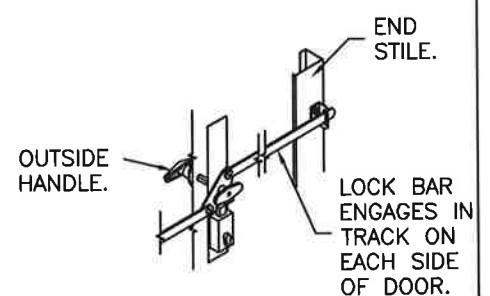

OUTSIDE KEYED LOCK WITH LOCK BAR LOCKING.

THIS PRODUCT COMPLIES WITH THE 2018 IBC/IRC.

DESIGN LOADS: +46.0 P.S.F. & -50.0 P.S.F.  
TEST LOADS: +69.0 P.S.F. & -75.0 P.S.F.

Unless Stated Otherwise TOLERANCES are

.0	= ±.031
.00	= ±.015
.000	= ±.005
.0000	= ±.001
Degrees	= ±1/2°

Unless Stated Otherwise DIMENSIONS ARE IN INCHES.

**Clopay** CORPORATION  
8585 Duke Boulevard  
Mason, OH 45040 USA  
Tel. No. 513-770-4800  
Fax No. 513-770-4853

MANUFACTURING PRODUCT CODE  
DSIE-1F171

PART NO.: N/A

WINDLOAD RATING  
**W8 DP46**

DESCRIPTION: 2" EPS INS. DOORS TO 18'2" (SEE TABLE FOR MODELS)

DRAWN BY: SH	DATE: 11/8/12	SCALE: NTS	DWG. B
CHECKED BY: SH	DATE: 11/9/12	SHEET 1 OF 3	

DWG. NO.: 104752  
VER: TDI

DESIGN ENGINEER  
MARK WESTERFIELD, P.E.  
FLORIDA P.E. #48495, NC P.E. #23832, TEXAS P.E. #91513

MODELS	27 GA SHORT	27 GA FLUSH	27 GA LONG
CLOPAY	4300, HDG	4301, HDGF	4310, HDGL
HOLMES	66, 66G, 6200	68, 6201	67, 67G, 6203
IDEAL	SP200	SF200	SE200

SHEET	REVISIONS					DESCRIPTION
	REV. NO.	ZONE	DATE	ECN NO.	APPVD.	
2 OF 3	05	-	-	-	-	SEE REVISION HISTORY ON SHEET ONE.

IN THE CASE OF GYPSUM WALLBOARD LOCATED AT OR NEAR THE DOOR OPENING LOCATION THERE ARE TWO ACCEPTABLE ALTERNATIVES:

- 1) THE WALLBOARD CAN BE CUT AWAY FROM THE DOOR OPENING AND 2X6 SOUTHERN YELLOW PINE WOOD JAMBS MOUNTED DIRECTLY TO THE SUPPORTING STRUCTURE TO CREATE THE MOUNTING SURFACE. ALTERNATIVELY, THE BRACKETS MAY BE ATTACHED DIRECTLY TO THE SUPPORTING STRUCTURE. SEE DETAIL BELOW. THE CENTER OF SCREW HOLE MUST BE AT LEAST 1/2" FROM BOTH EDGES FOR A 5/16" LAG SCREW.
- 2) IF THE WALLBOARD IS NOT CUT AWAY TO EXPOSE THE UNDERLYING STRUCTURE (WOOD FRAMING MEMBERS), A 2X6 SOUTHERN YELLOW PINE WOOD BUCK OVER SHALL BE INSTALLED THE WALLBOARD FRAMING THE OPENING USING THE JAMB ATTACHMENT FASTENERS LISTED BELOW. HOWEVER, THE JAMB ATTACHMENT FASTENERS MUST BE OF A SUFFICIENT INCREASED LENGTH TO ACCOUNT FOR THE THICKNESS OF THE WALLBOARD TO ENSURE PROPER FASTENER EMBEDMENT INTO THE STRUCTURAL FRAMING MEMBERS OF THE SUPPORTING STRUCTURE.

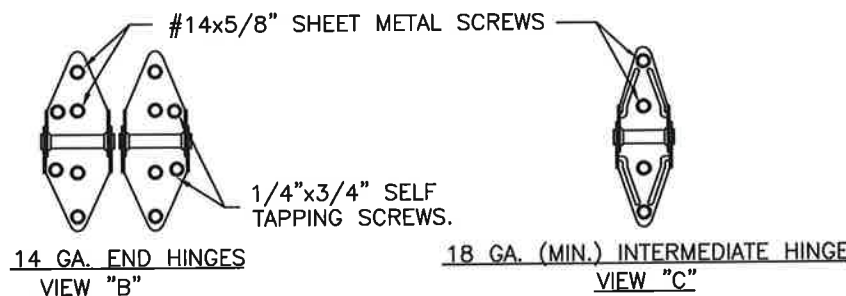
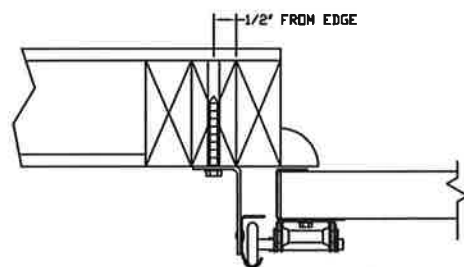

PREPARATION OF JAMBS BY OTHERS.

VERTICAL JAMB ATTACHMENT (WOOD FRAME BUILDINGS):

3/8"x3" LAG SCREWS ON 17" CENTERS. 1-1/8" O.D. WASHER REQUIRED. LAG SCREWS MAY BE COUNTERSUNK (BUT NOT REQUIRED) TO PROVIDE A FLUSH MOUNTING SURFACE. HORIZONTAL JAMBS DO NOT TRANSFER LOAD.

VERTICAL JAMB ATTACHMENT (C-90 BLOCK OR 2,000 PSI MIN. CONCRETE COLUMN):

3/8"x3" SLEEVE ANCHOR BOLTS ON 10" CENTERS (2,000 PSI MIN. CONCRETE). WASHERS INCLUDED WITH SLEEVE ANCHORS.

OR  
1/4"x3" TAPCON SCREWS ON 8" CENTERS (2,000 PSI MIN. CONCRETE) OR 5" CENTERS (C-90 BLOCK), 1" O.D. WASHERS REQUIRED WITH TAPCONS.

ANCHORS MAY BE COUNTERSUNK (BUT NOT REQUIRED) TO PROVIDE A FLUSH MOUNTING SURFACE. HORIZONTAL JAMBS DO NOT TRANSFER LOAD.

OTHER JAMB CONFIGURATIONS: REFER TO DASMA TDS-161. A LICENSED DESIGN PROFESSIONAL MAY ALSO BE EMPLOYED TO APPROVE ALTERNATE FASTENERS AND/OR JAMB CONFIGURATIONS.

DESIGN ENGINEER:  
MARK WESTERFIELD, P.E.  
FLORIDA P.E. #48495, NC P.E. #23832, TEXAS P.E. #91513

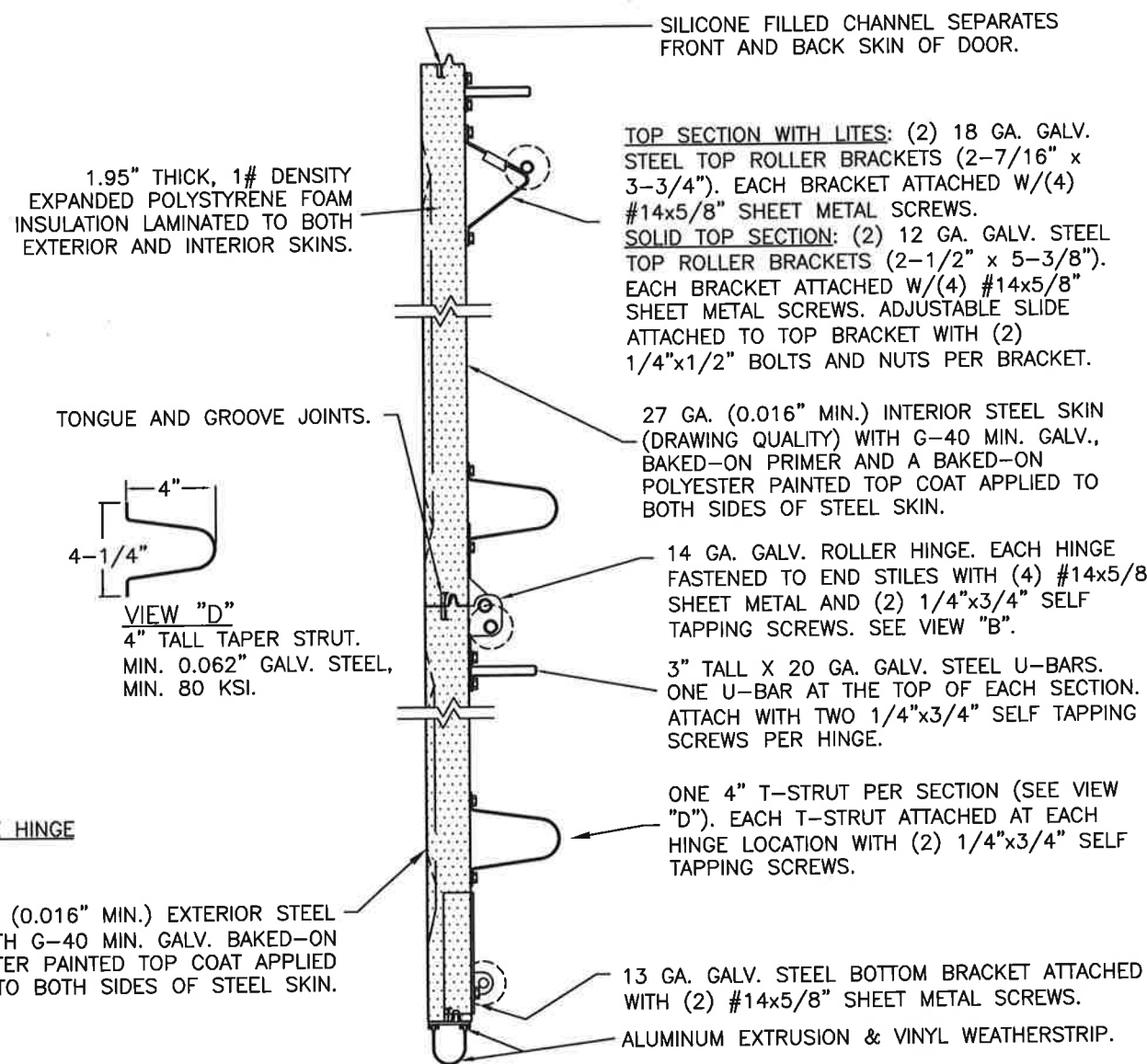

SECTION A-A (SIDE VIEW)

DESIGN LOADS: +46.0 P.S.F. & -50.0 P.S.F.  
TEST LOADS: +69.0 P.S.F. & -75.0 P.S.F.

Unless Stated Otherwise TOLERANCES are
.0 = ±.031
.00 = ±.015
.000 = ±.005
.0000 = ±.001
Degrees = ±1/2'
Unless Stated Otherwise DIMENSIONS ARE IN INCHES.

**Clopay**  
CORPORATION

8585 Duke Boulevard  
Mason, OH 45040 USA  
Tel. No. 513-770-4800  
Fax No. 513-770-4853

DESCRIPTION: 2" EPS INS. DOORS TO 18'2" (SEE TABLE FOR MODELS)			
DRAWN BY: SH	DATE: 11/8/12	SCALE: NTS	DWG. SIZE B
CHECKED BY: SH	DATE: 11/9/12	SHEET 2 OF 3	
DWG. NO.: 104752	VER: TDI		

MANUFACTURING PRODUCT CODE  
DSIE-1F171

PART NO.: N/A

WINDLOAD RATING  
W8 DP46

MODELS	27 GA SHORT	27 GA FLUSH	27 GA LONG
CLOPAY	4300, HDG	4301, HDGF	4310, HDGL
HOLMES	66, 66G, 6200	68, 6201	67, 67G, 6203
IDEAL	SP200	SF200	SE200

SHEET:  
3 OF 3

REVISIONS						DESCRIPTION
REV. NO.	ZONE:	DATE:	ECN NO.	APPVD:		
05	-	-	-	-		SEE REVISION HISTORY ON SHEET ONE.

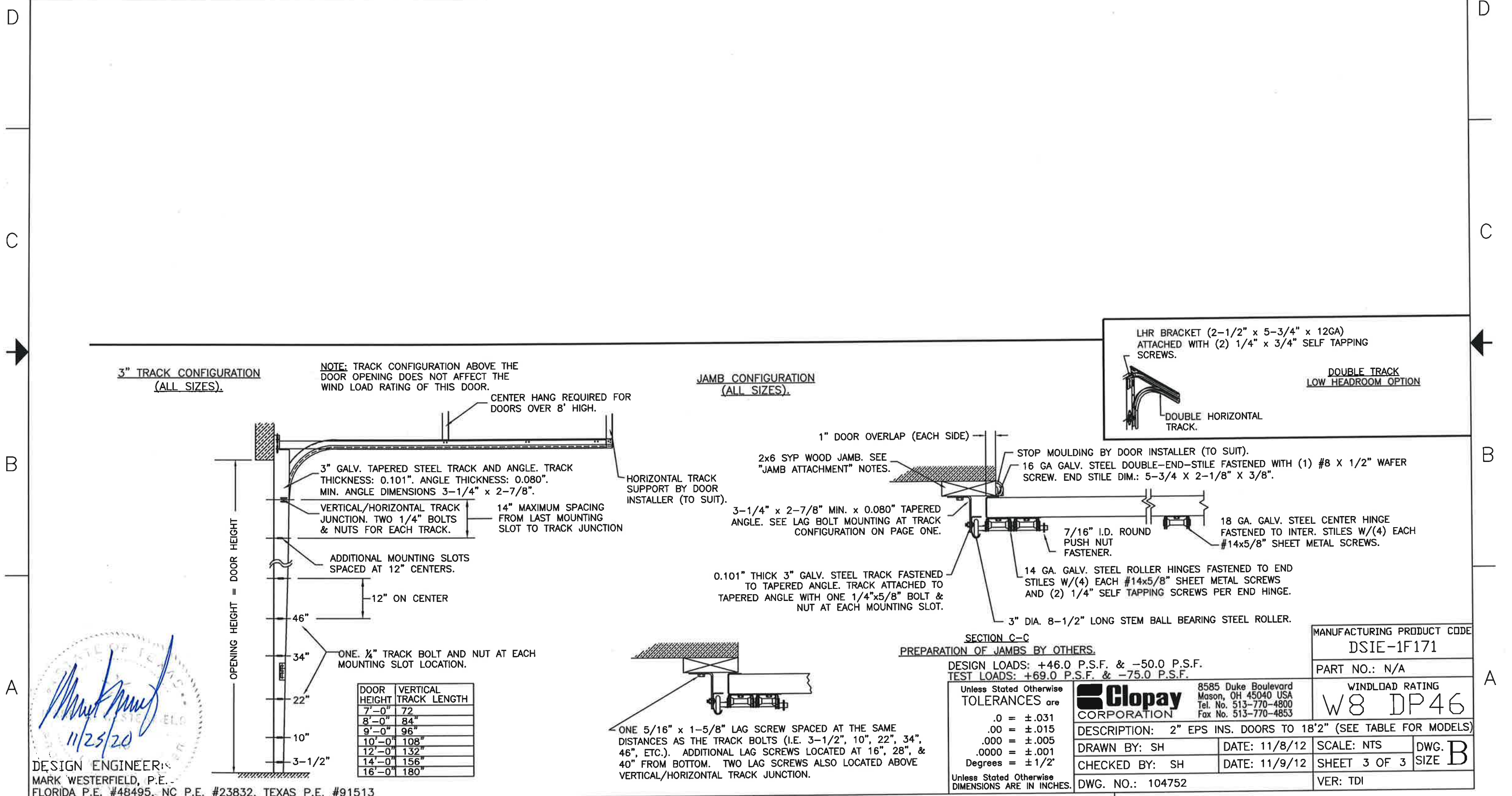

DOOR HEIGHT	VERTICAL TRACK LENGTH
7'-0"	72"
8'-0"	84"
9'-0"	96"
10'-0"	108"
12'-0"	132"
14'-0"	156"
16'-0"	180"

DESIGN ENGINEER:  
MARK WESTERFIELD, P.E.  
FLORIDA P.E. #48495, NC P.E. #23832, TEXAS P.E. #91513

11/25/20