

MODELS	27 GA SHORT	27 GA FLUSH	27 GA LONG
CLOPAY	4300, HDG	4301, HDGF	4310, HDGL
HOLMES	66, 66G, 6200	68, 6201	67, 67G, 6203
IDEAL	SP200	SF200	SE200

SHEET:
1 OF 4

REVISIONS					
REV. NO.	ZONE	DATE	ECN NO.	APPVD:	DESCRIPTION
06	-	2/4/20	-	SH	REVISED MAX WINDOW SIZE AND TITLE BLOCK
07	-	11/23/20	-	SH	ADDED COMPLIANCE STATEMENT.

THIS PRODUCT COMPLIES WITH THE 2018 IBC/IRC.

(1) 20 GA. BACKER PLATE BETWEEN EACH EMBOSS LOCATION THAT CONTAINS A CENTER HINGE. ATTACHED WITH DOUBLE SIDED ACRYLIC ADHESIVE TO BACK OF DOOR.

OPTIONAL IMPACT RESISTANT GLAZING.
MAX. IMPACT RESISTANT GLAZING IS 19-1/2"x12".
SEE SECTION B-B ON SHEET TWO FOR DETAILS.
(GLAZING SHOWN IN INTERMEDIATE SECTION.)

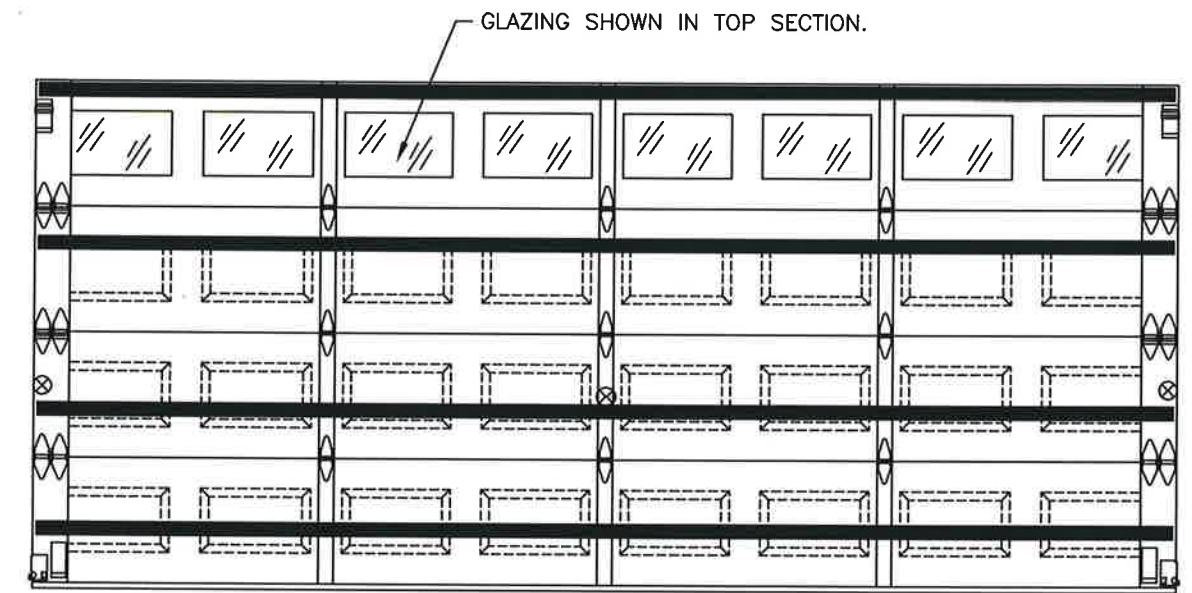
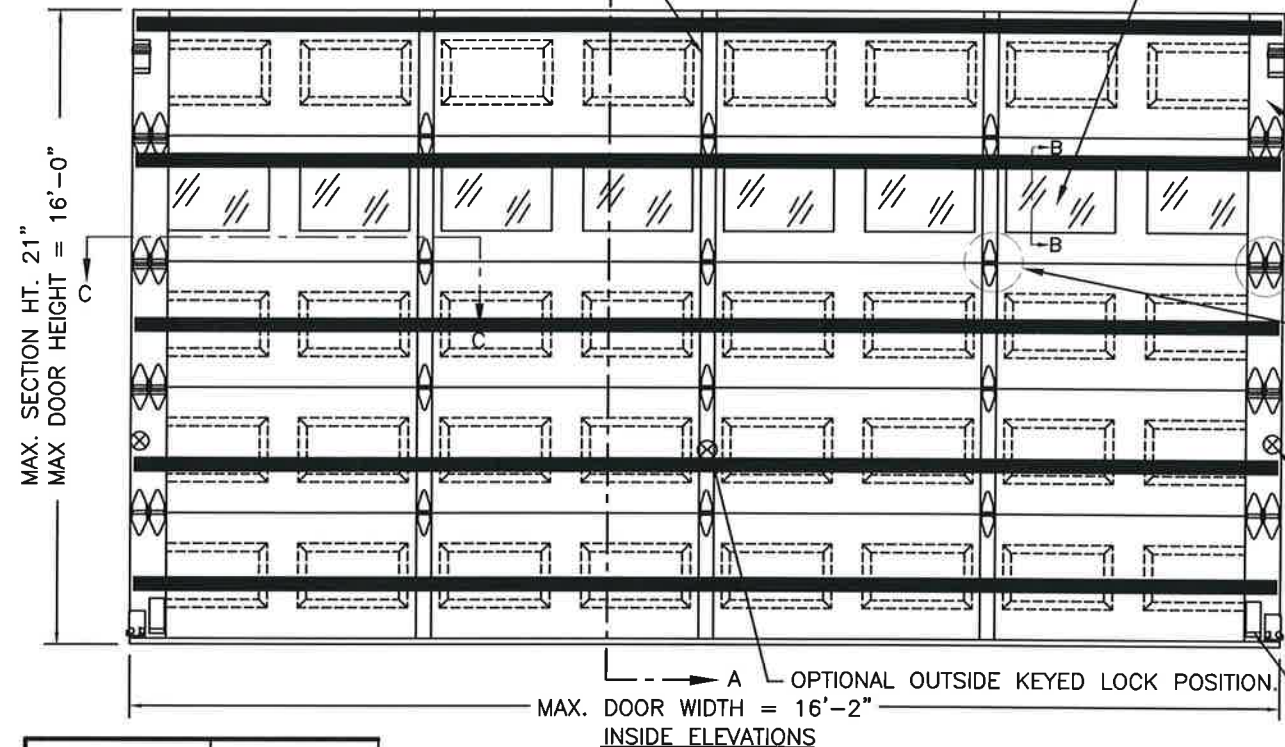

DOOR HEIGHT	# OF SECTIONS
UP TO 7'0"	4
7'3" TO 8'9"	5
9'0" TO 10'6"	6
10'9" TO 12'3"	7
12'6" TO 14'0"	8
14'3" TO 15'9"	9
16'0"	10
MAX SECTION HEIGHT: 21"	

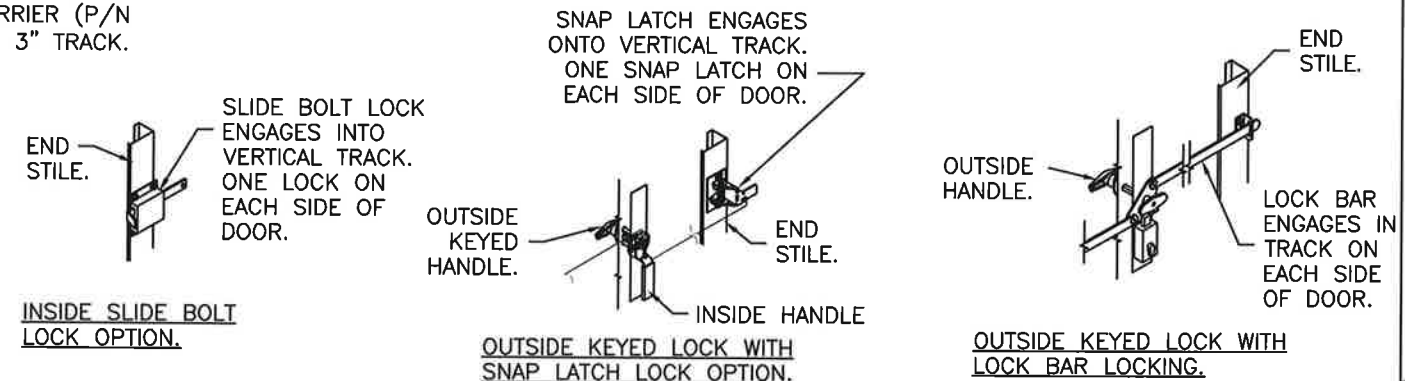

DESIGN ENGINEER
MARK WESTERFIELD, P.E.
FLORIDA P.E. #48495, NC P.E. #23832, TEXAS P.E. #91513

11/25/20

DESIGN LOADS: +38.0 P.S.F. & -42.0 P.S.F.
TEST LOADS: +57.0 P.S.F. & -63.0 P.S.F.

Unless Stated Otherwise TOLERANCES are

.0	= ±.031
.00	= ±.015
.000	= ±.005
.0000	= ±.001
Degrees	= ±1/2'

Clopay CORPORATION
8585 Duke Boulevard
Mason, OH 45040 USA
Tel. No. 513-770-4800
Fax No. 513-770-4853

MANUFACTURING PRODUCT CODE
DSIE-1F171

PART NO.: N/A

WINDLOAD RATING
W6 DP38

DESCRIPTION: 2" EPS INS. DOORS TO 16'2" (SEE TABLE FOR MODELS)	SCALE: NTS	DWG. SIZE: B
DRAWN BY: SH	DATE: 9/28/12	SHEET 1 OF 4
CHECKED BY: SH	DATE: 10/12/12	VER: TDI
DWG. NO.: 104724		

	4	3	2	1
MODELS	27 GA SHORT	27 GA FLUSH	27 GA LONG	
CLOPAY	4300, HDG	4301, HDGF	4310, HDGL	
HOLMES	66, 66G, 6200	68, 6201	67, 67G, 6203	
IDEAL	SP200	SF200	SE200	

SHEET:
2 OF 4

REVISIONS					
REV. NO.	ZONE	DATE	ECN NO.	APPVD:	DESCRIPTION
07	-	-	-	-	SEE REVISION HISTORY ON SHEET ONE.

IMPACT-RESISTANT CONSTRUCTION:
 SOLID DOORS (NO GLAZING) OR DOORS WITH OPTIONAL IMPACT-RESISTANT GLAZING ARE IMPACT-RESISTANT. OPTIONAL MAX WINDOW SIZE 19-1/2"x12" INJECTION-MOLDED POLYCARBONATE FRONT FRAME AND GLAZING IS GE LEXAN SLX2432T, AN APPROVED CC2 PLASTIC IN ACCORDANCE WITH IBC/FBC 2606 AND AN APPROVED C1 PLASTIC IN ACCORDANCE WITH FBC 2612. THE ENTIRE DOOR ASSEMBLY INSTALLED IN COMPLIANCE WITH THIS SECTION MEETS THE WIND LOAD REQUIREMENTS OF THE FLORIDA BUILDING CODE AND INTERNATIONAL BUILDING CODE AND IS LARGE- AND SMALL-MISSILE IMPACT RESISTANT.

SECTION B-B (IMPACT-RESISTANT GLAZING OPTION)

DETAIL 'D'

OPTIONAL DECORATIVE SNAP-IN INSERT.

MULTIPURPOSE HIGH BOND TAPE (BETWEEN FRAME AND FACADE).

DECORATIVE FRONT FACADE.

STRUCTURAL SILICONE SEALANT (BETWEEN STEEL SKIN AND FRAME).

IMPACT RESISTANT ONE-PIECE INJECTION MOLDED GE LEXAN SLX2432T FRONT FRAME & GLAZING.

POLYSTYRENE RETAINER FASTENED TO FRAME WITH (10) #8 x 3/4" PAN HEAD MACHINE SCREWS.

Dimensions: 2.25, 0.188

DESIGN ENGINEER:
 MARK WESTERFIELD, P.E.
 FLORIDA P.E. #48495, NC P.E. #23832, TEXAS P.E. #91513

DESIGN LOADS: +38.0 P.S.F. & -42.0 P.S.F.
 TEST LOADS: +57.0 P.S.F. & -63.0 P.S.F.

Unless Stated Otherwise
 TOLERANCES are
 .0 = ±.031
 .00 = ±.015
 .000 = ±.005
 .0000 = ±.001
 Degrees = ±1/2"

Unless Stated Otherwise
 DIMENSIONS ARE IN INCHES.

Clopay
 CORPORATION
 8585 Duke Boulevard
 Mason, OH 45040 USA
 Tel. No. 513-770-4800
 Fax No. 513-770-4853

DESCRIPTION: 2" EPS INS. DOORS TO 16'2" (SEE TABLE FOR MODELS)

DRAWN BY: SH DATE: 9/28/12 SCALE: NTS DWG. B

CHECKED BY: SH DATE: 10/12/12 SHEET 2 OF 4 SIZE B

DWG. NO.: 104724 VER: TDI

MANUFACTURING PRODUCT CODE
 DSIE-1F171

PART NO.: N/A

WINDLOAD RATING
 W6 DP38

MODELS	27 GA SHORT	27 GA FLUSH	27 GA LONG
CLOPAY	4300, HDG	4301, HDGF	4310, HDGL
HOLMES	66, 66G, 6200	68, 6201	67, 67G, 6203
IDEAL	SP200	SF200	SE200

SHEET:
3 OF 4

REVISIONS					
REV. NO.	ZONE:	DATE:	ECN NO.	APPVD:	DESCRIPTION
07	-	-	-	-	SEE REVISION HISTORY ON SHEET ONE.

IN THE CASE OF GYPSUM WALLBOARD LOCATED AT OR NEAR THE DOOR OPENING LOCATION THERE ARE TWO ACCEPTABLE ALTERNATIVES:

- 1) THE WALLBOARD CAN BE CUT AWAY FROM THE DOOR OPENING AND 2X6 SOUTHERN YELLOW PINE WOOD JAMBS MOUNTED DIRECTLY TO THE SUPPORTING STRUCTURE TO CREATE THE MOUNTING SURFACE. ALTERNATIVELY, THE BRACKETS MAY BE ATTACHED DIRECTLY TO THE SUPPORTING STRUCTURE. SEE DETAIL BELOW. THE CENTER OF SCREW HOLE MUST BE AT LEAST 1/2" FROM BOTH EDGES FOR A 5/16" LAG SCREW.
- 2) IF THE WALLBOARD IS NOT CUT AWAY TO EXPOSE THE UNDERLYING STRUCTURE (WOOD FRAMING MEMBERS), A 2X6 SOUTHERN YELLOW PINE WOOD BUCK OVER SHALL BE INSTALLED THE WALLBOARD FRAMING THE OPENING USING THE JAMB ATTACHMENT FASTENERS LISTED BELOW. HOWEVER, THE JAMB ATTACHMENT FASTENERS MUST BE OF A SUFFICIENT INCREASED LENGTH TO ACCOUNT FOR THE THICKNESS OF THE WALLBOARD TO ENSURE PROPER FASTENER EMBEDMENT INTO THE STRUCTURAL FRAMING MEMBERS OF THE SUPPORTING STRUCTURE.

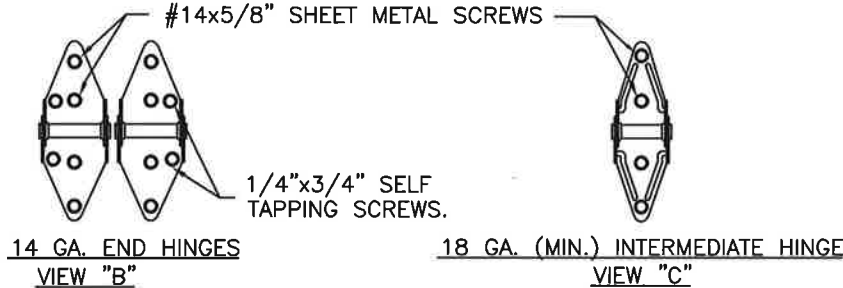
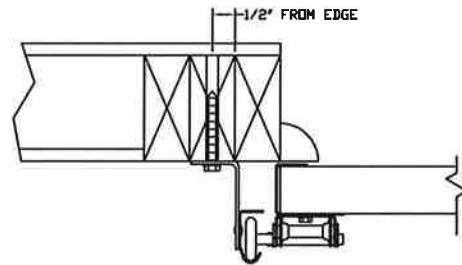

PREPARATION OF JAMBS BY OTHERS.

VERTICAL JAMB ATTACHMENT (WOOD FRAME BUILDINGS):

3/8"x3" LAG SCREWS ON 22" CENTERS. 1-1/8" O.D. WASHER REQUIRED. LAG SCREWS MAY BE COUNTERSUNK (BUT NOT REQUIRED) TO PROVIDE A FLUSH MOUNTING SURFACE. HORIZONTAL JAMBS DO NOT TRANSFER LOAD.

VERTICAL JAMB ATTACHMENT (C-90 BLOCK OR 2,000 PSI MIN. CONCRETE COLUMN):

3/8"x3" SLEEVE ANCHOR BOLTS ON 13" CENTERS (2,000 PSI MIN. CONCRETE). WASHERS INCLUDED WITH SLEEVE ANCHORS.

OR

1/4"x3" TAPCON SCREWS ON 11" CENTERS (2,000 PSI MIN. CONCRETE) OR 6" CENTERS (C-90 BLOCK), 1" O.D. WASHERS REQUIRED WITH TAPCONS.

ANCHORS MAY BE COUNTERSUNK (BUT NOT REQUIRED) TO PROVIDE A FLUSH MOUNTING SURFACE. HORIZONTAL JAMBS DO NOT TRANSFER LOAD.

OTHER JAMB CONFIGURATIONS: REFER TO DASMA TDS-161. A LICENSED DESIGN PROFESSIONAL MAY ALSO BE EMPLOYED TO APPROVE ALTERNATE FASTENERS AND/OR JAMB CONFIGURATIONS.

DESIGN ENGINEER
MARK WESTERFIELD, P.E.
FLORIDA P.E. #48495, NC P.E. #23832, TEXAS P.E. #91513

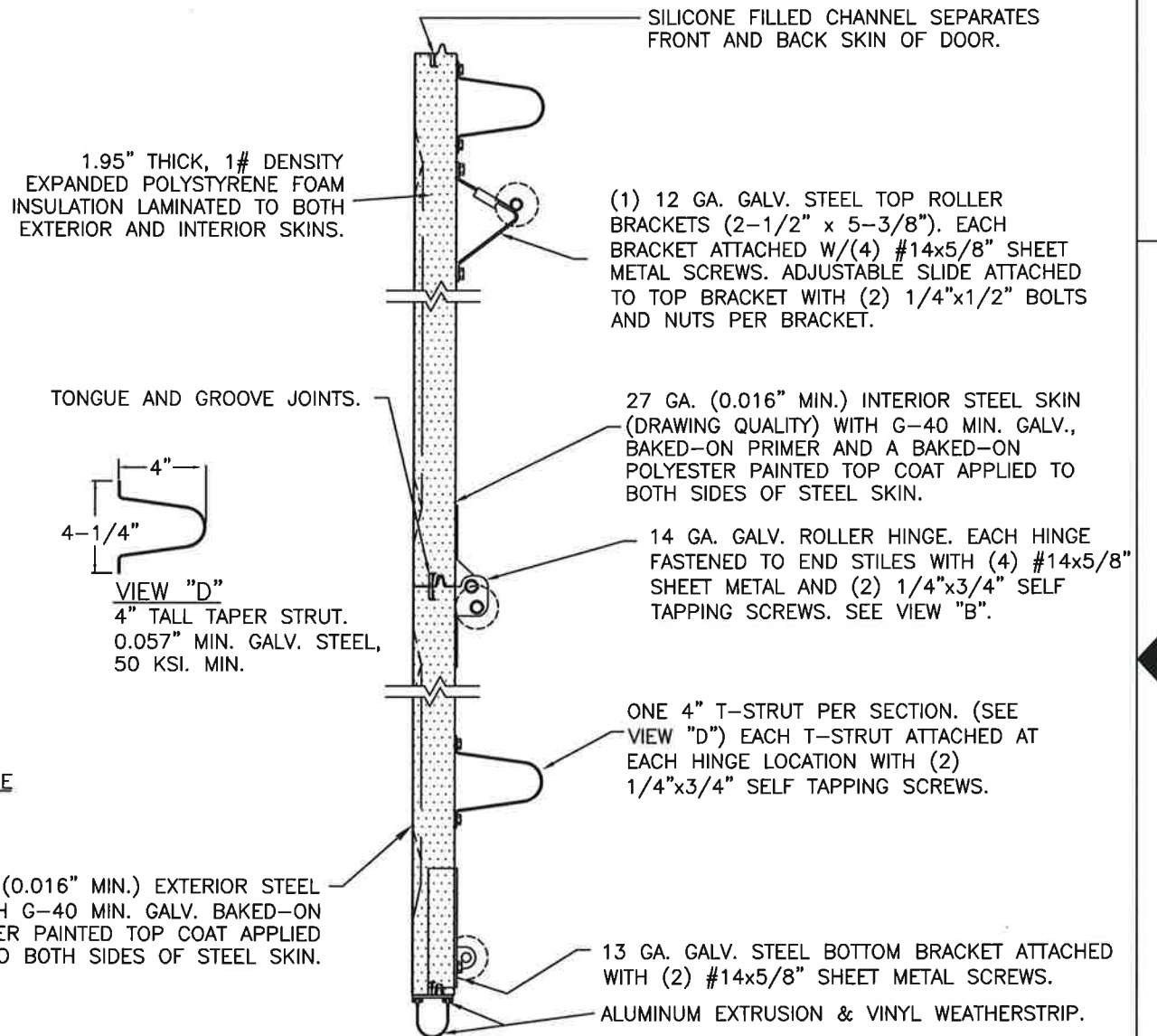

SECTION A-A (SIDE VIEW)

DESIGN LOADS: +38.0 P.S.F. & -42.0 P.S.F.
TEST LOADS: +57.0 P.S.F. & -63.0 P.S.F.

Unless Stated Otherwise TOLERANCES are

.0	= ±.031
.00	= ±.015
.000	= ±.005
.0000	= ±.001
Degrees	= ±1/2'

Unless Stated Otherwise DIMENSIONS ARE IN INCHES.

Clopay
CORPORATION

8585 Duke Boulevard
Mason, OH 45040 USA
Tel. No. 513-770-4800
Fax No. 513-770-4853

MANUFACTURING PRODUCT CODE
DSIE-1F171

PART NO.: N/A

WINDLOAD RATING
W6 DP38

DESCRIPTION: 2" EPS INS. DOORS TO 16'2" (SEE TABLE FOR MODELS)

DRAWN BY: SH	DATE: 9/28/12	SCALE: NTS	DWG. SIZE B
CHECKED BY: SH	DATE: 10/12/12	SHEET 3 OF 4	

DWG. NO.: 104724	VER: TDI
------------------	----------

MODELS	27 GA SHORT	27 GA FLUSH	27 GA LONG
CLOPAY	4300, HDG	4301, HDGF	4310, HDGL
HOLMES	66, 66G, 6200	68, 6201	67, 67G, 6203
IDEAL	SP200	SF200	SE200

SHEET: 4 OF 4	REVISIONS					
	REV. NO.	ZONE:	DATE:	ECN NO.	APPVD:	DESCRIPTION
	07	-	-	-	-	SEE REVISION HISTORY ON SHEET ONE.

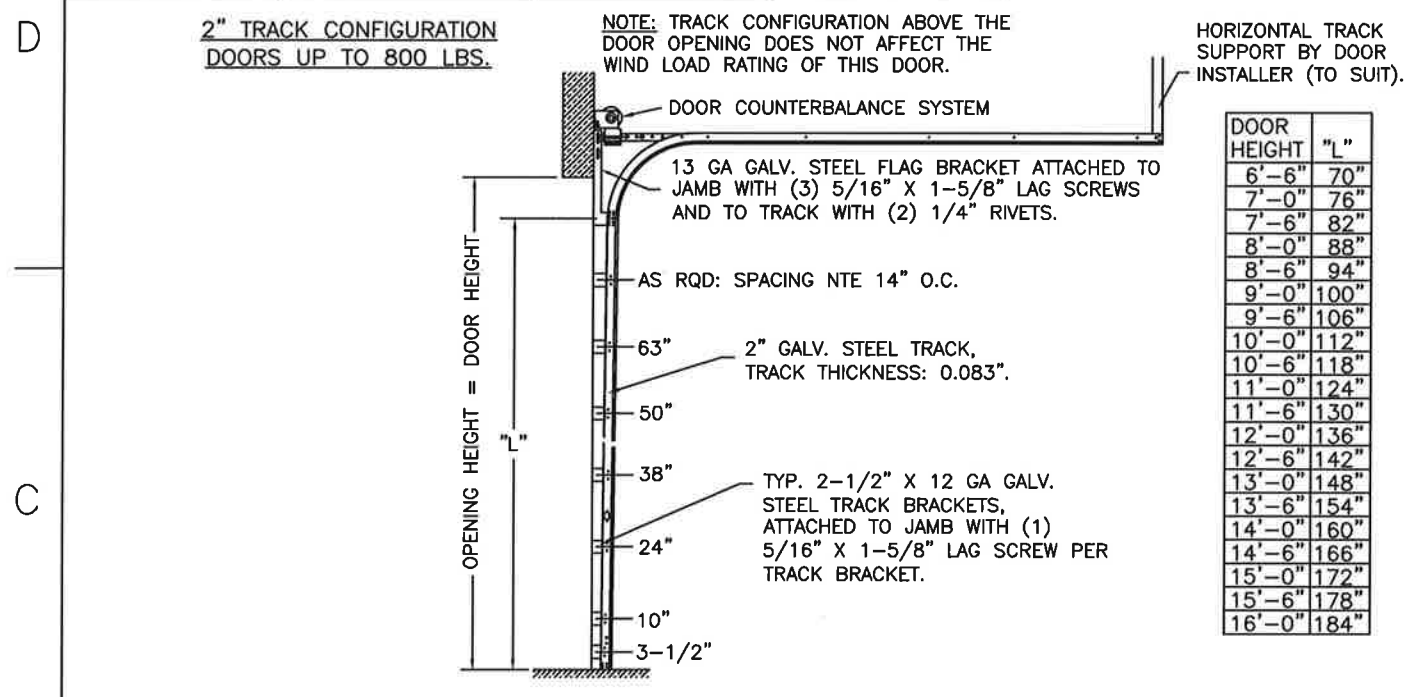

HORIZONTAL TRACK SUPPORT BY DOOR INSTALLER (TO SUIT).

DOOR HEIGHT "L"	"L"
6'-6"	70"
7'-0"	76"
7'-6"	82"
8'-0"	88"
8'-6"	94"
9'-0"	100"
9'-6"	106"
10'-0"	112"
10'-6"	118"
11'-0"	124"
11'-6"	130"
12'-0"	136"
12'-6"	142"
13'-0"	148"
13'-6"	154"
14'-0"	160"
14'-6"	166"
15'-0"	172"
15'-6"	178"
16'-0"	184"

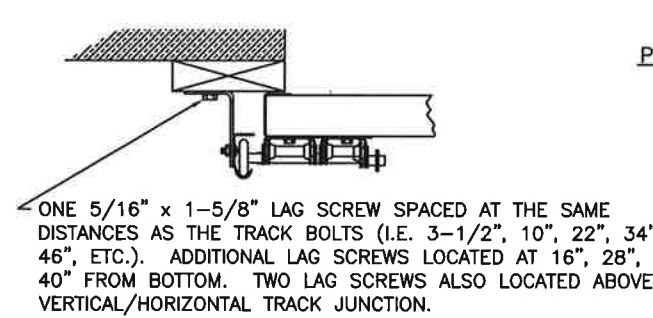
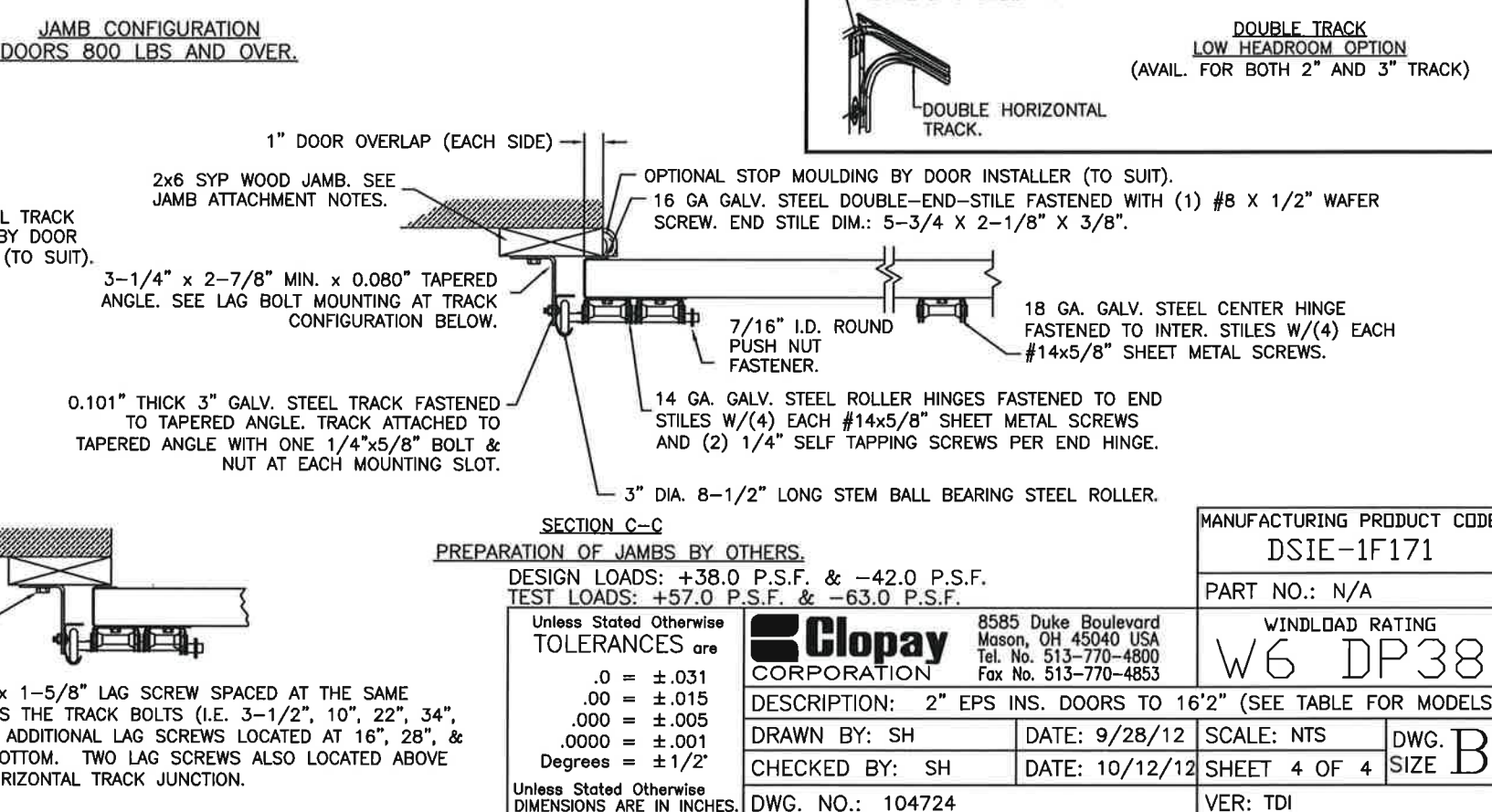
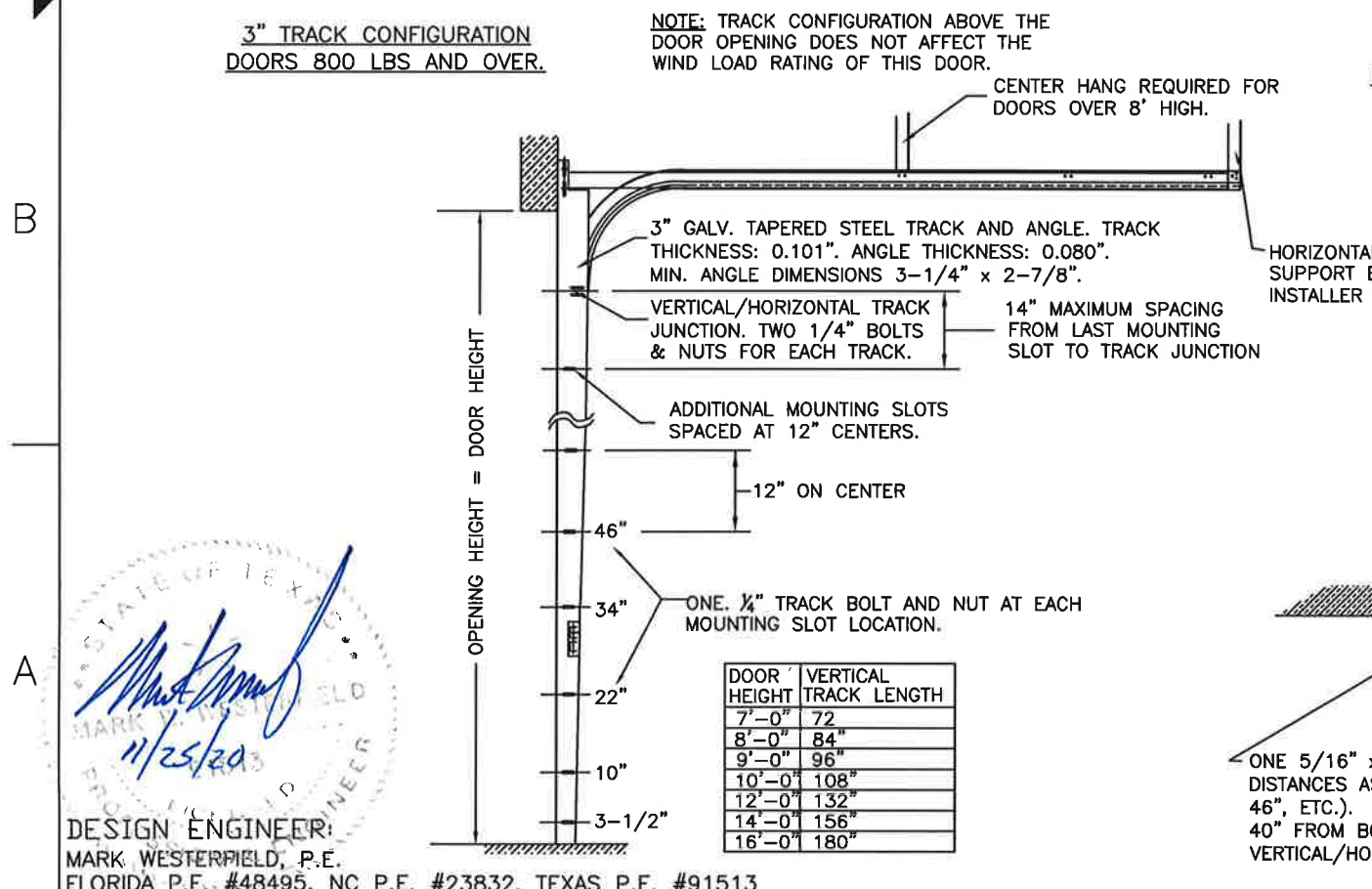
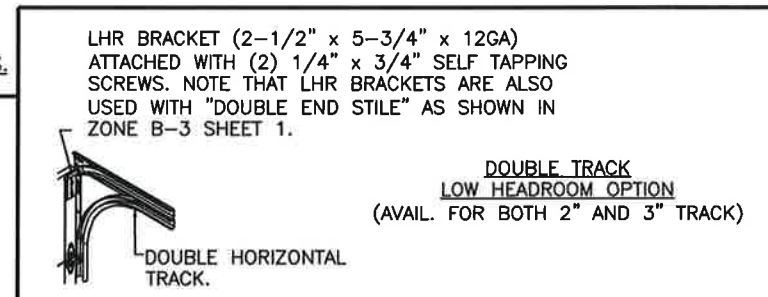
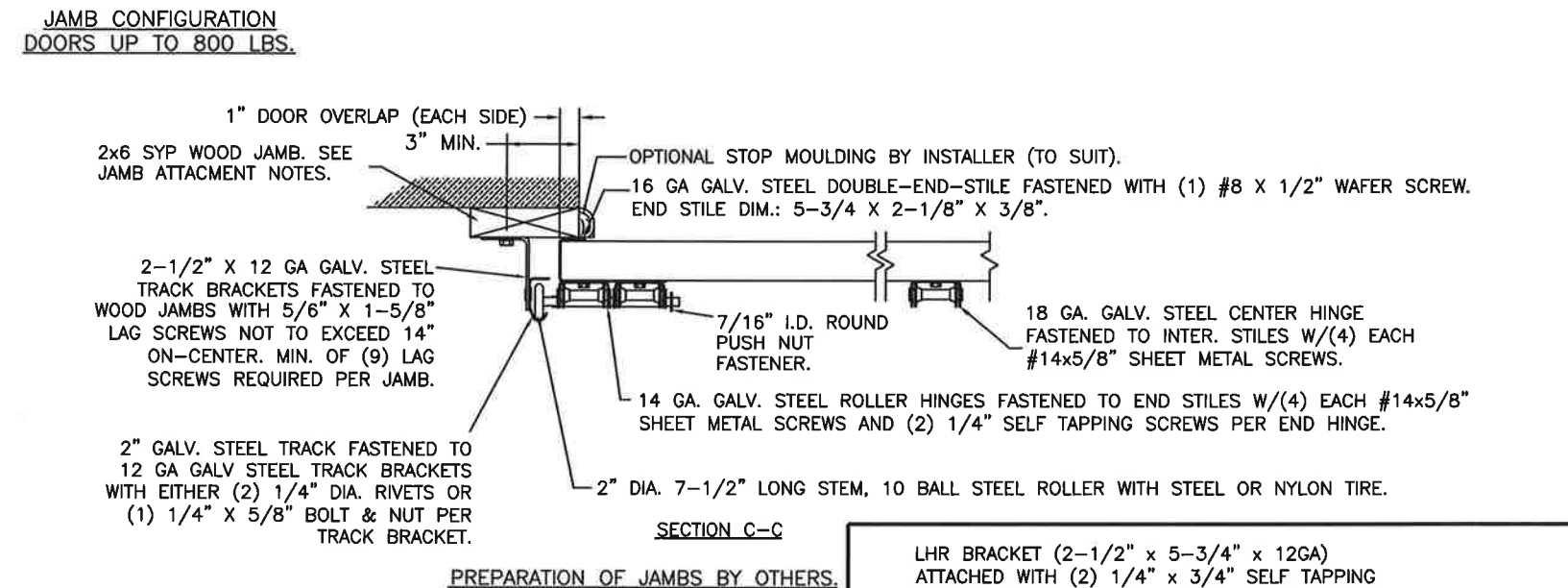

DESIGN ENGINEER:
MARK WESTERFIELD, P.E.
FLORIDA P.E. #48495, NC P.E. #23832, TEXAS P.E. #91513

11/25/20

MANUFACTURING PRODUCT CODE DSIE-1F171	8585 Duke Boulevard Mason, OH 45040 USA Tel. No. 513-770-4800 Fax No. 513-770-4853	WINDLOAD RATING W6 DP38
PART NO.: N/A	DESCRIPTION: 2" EPS INS. DOORS TO 16'2" (SEE TABLE FOR MODELS)	SCALE: NTS
DRAWN BY: SH	DATE: 9/28/12	DWG. B
CHECKED BY: SH	DATE: 10/12/12	SHEET 4 OF 4
DWG. NO.: 104724	VER: TDI	