

MODELS	24 GA SHORT	27 GA SHORT	27 GA FLUSH	27 GA LONG
CLOPAY	4400, 4401	4300, HDG	4301, HDGF	4310, HDGL
HOLMES	---	66, 66G, 6200	68, 6201	67, 67G, 6203
IDEAL	---	SP200	SF200	SE200

DOOR HEIGHT	# OF SECTIONS	# OF STRUTS
UP TO 7'0"	4	3
7'3" TO 8'0"	5	3
8'3" TO 8'9"	5	4
9'0" TO 10'6"	6	4
10'9" TO 12'3"	7	5
12'6" TO 14'0"	8	6
14'3" TO 15'9"	9	7
16'0"	10	8
MAX SECTION HEIGHT: 21'		

EQUIVALENT SECTION CONSTRUCTION: FOR ANY OF THE MODELS LISTED ON THIS DRAWING, THE FOLLOWING W-LEVEL DOORS USE EQUIVALENT SECTIONS (UP TO THE MAXIMUM WIDTH ALLOWED ON THIS DRAWING).
W1, W4, W6, W8.
 ANY OF THESE W-LEVELS MAY BE SHOWN ON THE OPTIONAL SHIPPING LABEL ON THE END STILE.

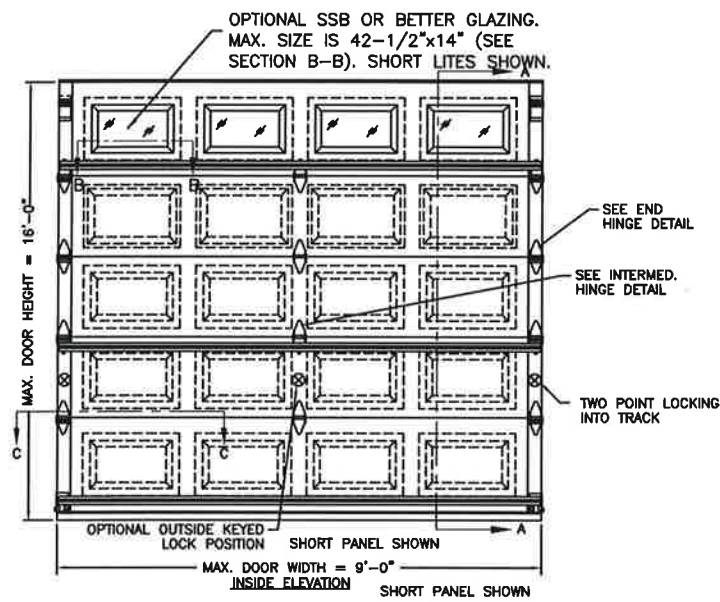
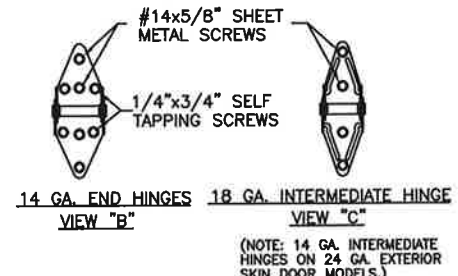
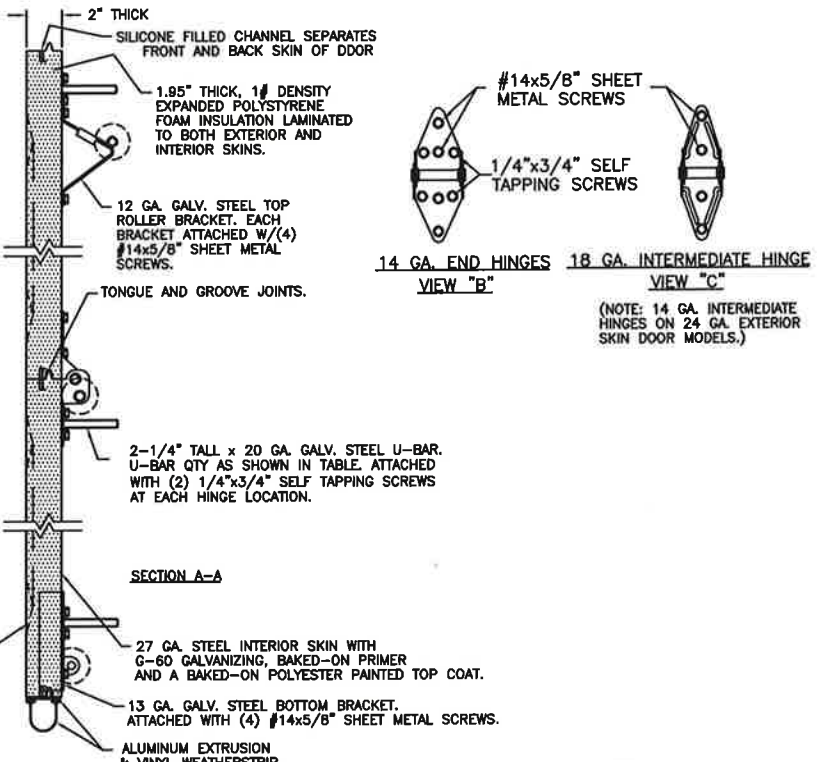
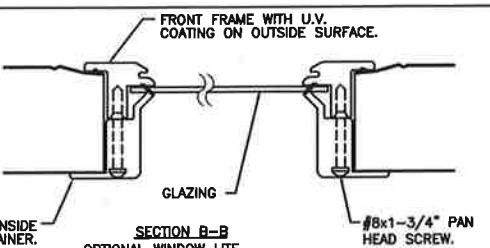

REV	DESCRIPTION
04	8/2004 ADDED M/N SP20, SE20, SF20
05	6/2005 UPDATED CODE REF.
06	9/2005 ADDED ROLLER OPTION
07	11/30/07 ADDED EXTENDED HEIGHTS AND COMBINED HOLMES AND CLOPAY M/N
08	5/12/07 ADDED MPC INFO AND HDGF, 66G, 67G
09	10/2009 REVISED FOR TDI
10	08/2016 REMOVE WIND SPEED TABLE.
11	11/23/20 UPDATED TITLE BLOCK AND ADDED COMPLIANCE STATEMENT.

THIS PRODUCT COMPLIES WITH THE 2018 IBC/IRC.

THE OPTIONAL GLAZING SHOWN ON THIS DRAWING MEETS THE WIND LOAD REQUIREMENTS OF THE FLORIDA BUILDING CODE OR INTERNATIONAL BUILDING CODE BUT DOES NOT MEET THE IMPACT RESISTANT REQUIREMENT FOR WINDBORNE DEBRIS REGIONS (REF. CHAPTER 16 FBC/IBC)

IN THE CASE OF GYPSUM WALLBOARD LOCATED AT OR NEAR THE DOOR OPENING LOCATION THERE ARE TWO ACCEPTABLE ALTERNATIVES:
 1) THE WALLBOARD CAN BE CUT AWAY FROM THE DOOR OPENING AND 2X6 SOUTHERN YELLOW PINE WOOD JAMBS MOUNTED DIRECTLY TO THE SUPPORTING STRUCTURE TO CREATE THE MOUNTING SURFACE. ALTERNATIVELY, THE BRACKETS MAY BE ATTACHED DIRECTLY TO THE SUPPORTING STRUCTURE. SEE DETAIL BELOW. THE CENTER OF SCREW HOLE MUST BE AT LEAST 1/2" FROM BOTH EDGES FOR A 5/16" LAG SCREW.
 2) IF THE WALLBOARD IS NOT CUT AWAY TO EXPOSE THE UNDERLYING STRUCTURE (WOOD FRAMING MEMBERS), A 2X6 SOUTHERN YELLOW PINE WOOD BUCK OVER SHALL BE INSTALLED THE WALLBOARD FRAMING THE OPENING USING THE JAMB ATTACHMENT FASTENERS LISTED BELOW. HOWEVER, THE JAMB ATTACHMENT FASTENERS MUST BE OF A SUFFICIENT INCREASED LENGTH TO ACCOUNT FOR THE THICKNESS OF THE WALLBOARD TO ENSURE PROPER FASTENER EMBEDMENT INTO THE STRUCTURAL FRAMING MEMBERS OF THE SUPPORTING STRUCTURE.

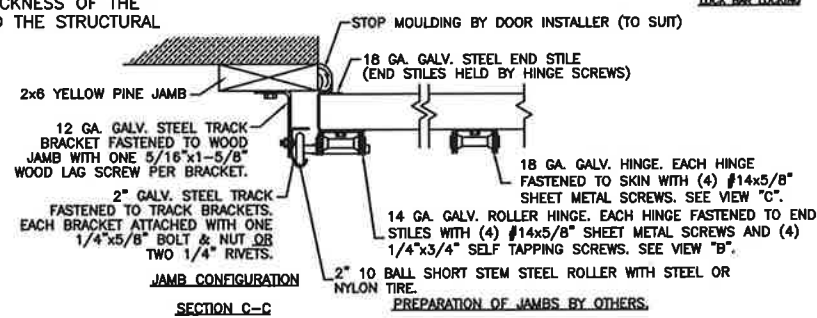
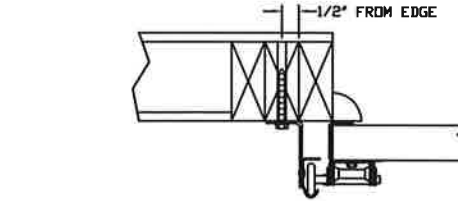

VERTICAL JAMB ATTACHMENT (WOOD FRAME BUILDINGS):
 3/8"x3" LAG SCREWS ON 24" CENTERS. 1-1/8" O.D. WASHER REQUIRED. LAG SCREWS MAY BE COUNTERSUNK (BUT NOT REQUIRED) TO PROVIDE A FLUSH MOUNTING SURFACE. HORIZONTAL JAMBS DO NOT TRANSFER LOAD.

VERTICAL JAMB ATTACHMENT (C-90 BLOCK OR 2,000 PSI MIN. CONCRETE COLUMN):
 3/8"x3" SLEEVE ANCHOR BOLTS ON 24" CENTERS (2,000 PSI MIN. CONCRETE). WASHERS INCLUDED WITH SLEEVE ANCHORS.
 OR
 1/4"x3" TAPCON SCREWS ON 24" CENTERS (2,000 PSI MIN. CONCRETE) OR 14" CENTERS (C-90 BLOCK), 1" O.D. WASHERS REQUIRED WITH TAPCONS. ANCHORS MAY BE COUNTERSUNK (BUT NOT REQUIRED) TO PROVIDE A FLUSH MOUNTING SURFACE. HORIZONTAL JAMBS DO NOT TRANSFER LOAD.

OTHER JAMB CONFIGURATIONS: REFER TO DASMA TDS-161. A LICENSED DESIGN PROFESSIONAL MAY ALSO BE EMPLOYED TO APPROVE ALTERNATE FASTENERS AND/OR JAMB CONFIGURATIONS.

NOTE: THE DESIGN OF THE SUPPORTING STRUCTURAL ELEMENTS SHALL BE THE RESPONSIBILITY OF THE PROFESSIONAL OF RECORD FOR THE BUILDING OR STRUCTURE AND IN ACCORDANCE WITH CURRENT BUILDING CODES FOR THE LOADS LISTED ON THE DRAWING.

ORIGINAL DRAWINGS ARE SIGNED IN BLUE INK WITH A RAISED SEAL (EMBOS).

DESIGN ENGINEER: MARK WESTERFIELD, P.E.
 FLORIDA P.E. #48495,
 NC P.E. #23832,
 TEXAS P.E. #91513

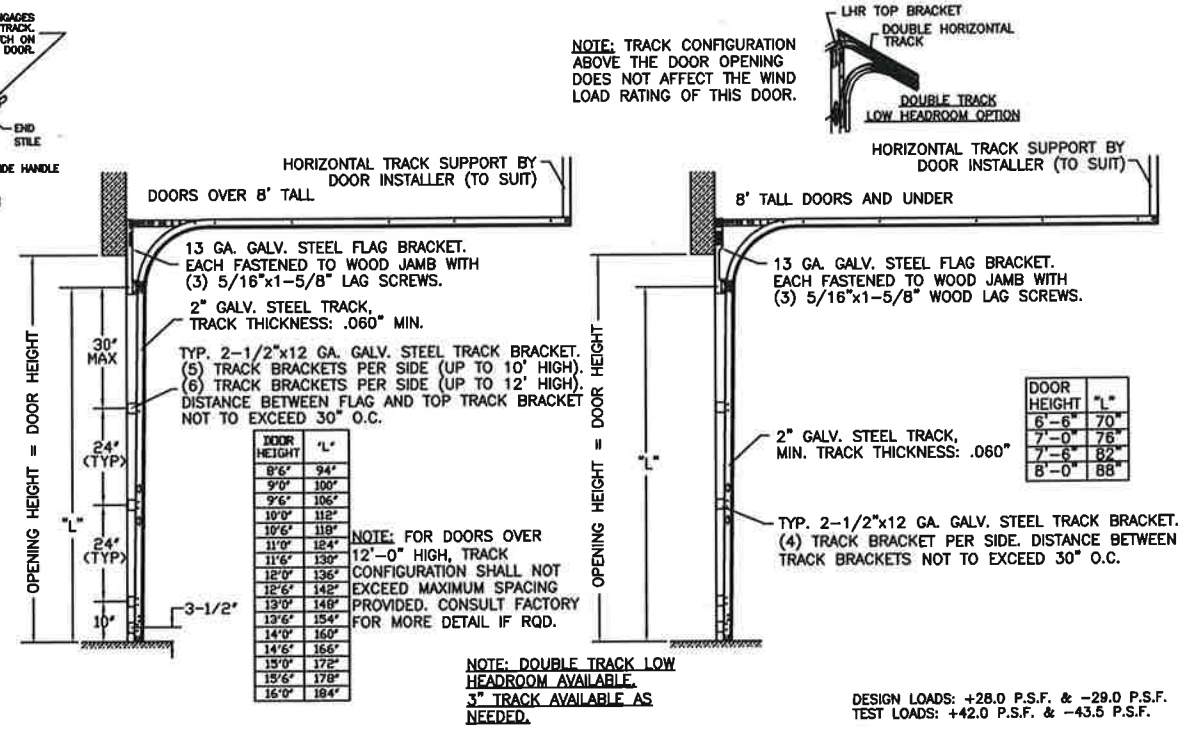

DOOR HEIGHT	L'
8'6"	94"
9'0"	100"
9'6"	106"
10'0"	112"
10'6"	118"
11'0"	124"
11'6"	130"
12'0"	136"
12'6"	142"
13'0"	148"
13'6"	154"
14'0"	160"
14'6"	166"
15'0"	172"
15'6"	178"
16'0"	184"

NOTE: FOR DOORS OVER 12'-0" HIGH, TRACK CONFIGURATION SHALL NOT EXCEED MAXIMUM SPACING PROVIDED. CONSULT FACTORY FOR MORE DETAIL IF RQD.

NOTE: DOUBLE TRACK LOW HEADROOM AVAILABLE. 3" TRACK AVAILABLE AS NEEDED.

DESIGN LOADS: +28.0 P.S.F. & -29.0 P.S.F.
 TEST LOADS: +42.0 P.S.F. & -43.5 P.S.F.

Glopay CORPORATION

5858 DUKE BLVD.
 MASON, OH 45040
 (513) 770-4800

Clipay Corporation All Rights Reserved.

MANUFACTURING PRODUCT CODE MPC: DSIE-1F171	WINDLOAD RATING W4	MAXIMUM DOOR SIZE: 9'0"W X 16'0"H
DATE: 7/12/96	DESCRIPTION: M/N 4300/4400: +28/-29 PSF	
DRAWN BY: MWW	DRAWING NUMBER: B 101652	VER: TDI
CHECKED BY:		