



WIND LOAD DOOR INSTALLATION SUPPLEMENT

John E. Scates, P.E.
2560 King Arthur Blvd Ste 124-54
Lewisville, Texas 75056
TX PE 56308/F2203

ADDITIONAL GARAGE DOOR WOOD JAMB CONNECTION

Supplement to Haas Door Texas Drawings

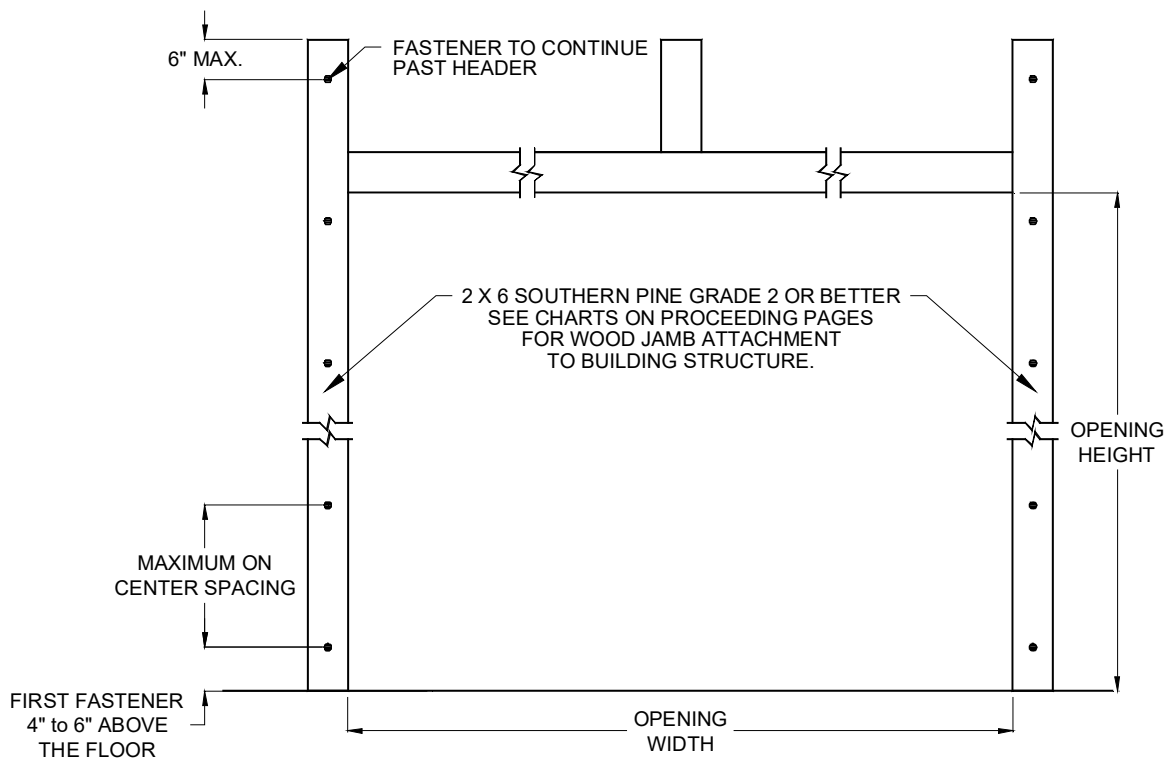

Notes:

1. Vertical jambs should be minimum 2x6 Southern Pine lumber, free of cracks, splits, and knots in the area of attachment fasteners.
2. If the 2x6 is to be mounted on top of drywall the length of the fastener must be increased to ensure proper fastener engagement.
3. Alternate attachment may be approved by a registered professional engineer.
4. Building structure for which the jambs are to be attached shall be designed by a registered professional engineer taking into account wind loads in addition to other loads.
5. Only use those brand of fasteners mentioned in this supplement for each application.
6. Consult fastener manufacturer for proper application and installation and check the applicable local regulations.

Fastener Types Covered



3/8" Lag Screw



Concrete Self-Tapping Anchor



Concrete Wedge Anchor



L-Hook Anchor



Heavy-Duty Screw Anchor

Mounting 2x6 to a building with wood walls/jamb
3/8" x 3" Lag Screw w/ 1-1/8" O.D Flat Washer
 Min. Embedment 1-1/2", Min. Edge Distance 1-1/2"

For Southern Pine building walls/jamb, Specific Gravity = 0.55
620 lbs. per anchor allowable load

Design Wind Load (psf)	Maximum on-center spacing (inches)											
	Opening Width (ft.-in.)											
	9' -0"	10' -0"	12' -0"	14' -0"	16' -0"	18' -0"	20' -0"	22' -0"	24' -0"	26' -0"	28' -0"	30' -0"
20	30	30	30	30	30	30	30	30	30	28	26	24
25	30	30	30	30	30	30	29	27	24	22	21	19
30	30	30	30	30	30	27	24	22	20	19	17	16
35	30	30	30	30	26	23	21	19	17	16	15	14
40	30	30	30	26	23	20	18	16	15	14	13	12
45	30	30	27	23	20	18	16	15	13	12	11	11
50	30	29	24	21	18	16	14	13	12	11	10	9
55	30	27	22	19	16	15	13	12	11	10	9	9
60	27	24	20	17	15	13	12	11	10	9	8	8
65	25	22	19	16	14	12	11	10	9	8	8	7

For Spruce-Pine-Fir (SPF) building walls/jamb, Specific Gravity = 0.42
482 lbs. per anchor allowable load

Design Wind Load (psf)	Maximum on-center spacing (inches)											
	Opening Width (ft.-in.)											
	9' -0"	10' -0"	12' -0"	14' -0"	16' -0"	18' -0"	20' -0"	22' -0"	24' -0"	26' -0"	28' -0"	30' -0"
20	30	30	30	30	30	30	28	26	24	22	20	19
25	30	30	30	30	28	25	23	21	19	17	16	15
30	30	30	30	27	24	21	19	17	16	14	13	12
35	30	30	27	23	20	18	16	15	13	12	11	11
40	30	28	24	20	18	16	14	13	12	11	10	9
45	28	25	21	18	16	14	12	11	10	9	9	8
50	25	23	19	16	14	12	11	10	9	8	8	7
55	23	21	17	15	13	11	10	9	8	8	7	7
60	21	19	16	13	12	10	9	8	8	7	6	6
65	19	17	14	12	11	9	8	8	7	6	6	5

Notes:

1. In all instances, 2x6 is Southern Pine.
2. Wood jamb can be counter bored up to 3/8" deep to provide flush mounting.
3. Pre-drill 1/4" diameter holes at each fastener location.
4. Lag screws must conform to ANSI/ASME Standard B18.2.1.
5. See figure on second page for spacing details and other information.

Mounting 2x6 to a building with concrete walls/jamb
1/4" Diameter Concrete Self-Tapping Anchor w/1-1/4" O.D Flat Washer
(Includes Buildex Tapcon+ (PLUS))
Min. Embedment 2", Min. Edge Distance 2-1/2", Min. Spacing 5"

2500 psi Concrete, using 1-1/4" O.D. flat washer

833 lbs. per anchor allowable load

Design Wind Load (psf)	Maximum on-center spacing (inches)											
	Opening Width (ft.-in.)											
	9' -0"	10' -0"	12' -0"	14' -0"	16' -0"	18' -0"	20' -0"	22' -0"	24' -0"	26' -0"	28' -0"	30' -0"
20	30	30	30	30	30	30	30	30	30	30	28	28
25	30	30	30	30	30	30	30	29	28	26	25	25
30	30	30	30	30	30	29	28	26	25	24	23	22
35	30	30	30	30	28	27	25	24	23	21	20	19
40	30	30	30	28	27	25	24	22	20	19	17	16
45	30	30	29	27	25	24	22	20	18	17	15	14
50	30	30	28	25	24	22	19	18	16	15	14	13
55	30	29	26	24	22	20	18	16	15	13	12	12
60	29	28	25	23	20	18	16	15	13	12	11	11
65	28	26	24	21	19	17	15	13	12	11	10	10

3000 psi Concrete, using 1-1/4" O.D. flat washer

833 lbs. per anchor allowable load

Design Wind Load (psf)	Maximum on-center spacing (inches)											
	Opening Width (ft.-in.)											
	9' -0"	10' -0"	12' -0"	14' -0"	16' -0"	18' -0"	20' -0"	22' -0"	24' -0"	26' -0"	28' -0"	30' -0"
20	30	30	30	30	30	30	30	30	30	30	28	28
25	30	30	30	30	30	30	30	29	28	26	25	25
30	30	30	30	30	30	29	28	26	25	24	23	22
35	30	30	30	30	28	27	25	24	23	21	20	19
40	30	30	30	28	27	25	24	22	20	19	17	16
45	30	30	29	27	25	24	22	20	18	17	15	14
50	30	30	28	25	24	22	19	18	16	15	14	13
55	30	29	26	24	22	20	18	16	15	13	12	12
60	29	28	25	23	20	18	16	15	13	12	11	11
65	28	26	24	21	19	17	15	13	12	11	10	10

4000 psi Concrete, using 1-1/4" O.D. flat washer

833 lbs. per anchor allowable load

Design Wind Load (psf)	Maximum on-center spacing (inches)											
	Opening Width (ft.-in.)											
	9' -0"	10' -0"	12' -0"	14' -0"	16' -0"	18' -0"	20' -0"	22' -0"	24' -0"	26' -0"	28' -0"	30' -0"
20	30	30	30	30	30	30	30	30	30	30	28	28
25	30	30	30	30	30	30	30	29	28	26	25	25
30	30	30	30	30	30	29	28	26	25	24	23	22
35	30	30	30	30	28	27	25	24	23	21	20	19
40	30	30	30	28	27	25	24	22	20	19	17	16
45	30	30	29	27	25	24	22	20	18	17	15	14
50	30	30	28	25	24	22	19	18	16	15	14	13
55	30	29	26	24	22	20	18	16	15	13	12	12
60	29	28	25	23	20	18	16	15	13	12	11	11
65	28	26	24	21	19	17	15	13	12	11	10	10

Notes:

1. In all instances, 2x6 is Southern Pine.
2. Wood jamb can be counter bored up to 3/8" deep to provide flush mounting.
3. See figure on second page for spacing details and other information.

Mounting 2x6 to a building with concrete walls/jamb
1/4" Diameter Concrete Wedge Anchor w/Flat Washer (see size below)

(Includes Powers Wedge-Bolt+ and ITW Red Head TruBolt)
 Min. Embedment 1-3/4", Min. Edge Distance 2-1/2", Min. Spacing 5"

2500 psi Concrete, using 1" O.D. flat washer

551 lbs. per anchor allowable load

Design Wind Load (psf)	Maximum on-center spacing (inches)											
	Opening Width (ft.-in.)											
	9' -0"	10' -0"	12' -0"	14' -0"	16' -0"	18' -0"	20' -0"	22' -0"	24' -0"	26' -0"	28' -0"	30' -0"
20	30	30	30	30	30	30	30	30	28	25	24	22
25	30	30	30	30	30	29	26	24	22	20	19	17
30	30	30	30	30	28	24	22	20	18	17	16	14
35	30	30	30	27	24	21	19	17	16	14	13	12
40	30	30	28	24	21	18	16	15	14	12	12	11
45	30	29	24	21	18	16	14	13	12	11	10	9
50	29	26	22	19	16	14	13	12	11	10	9	8
55	27	24	20	17	15	13	12	11	10	9	8	8
60	24	22	18	16	14	12	11	10	9	8	8	7
65	23	20	17	14	12	11	10	9	8	7	7	6

3000 psi Concrete, using 1-1/8" O.D. flat washer

616 lbs. per anchor allowable load

Design Wind Load (psf)	Maximum on-center spacing (inches)											
	Opening Width (ft.-in.)											
	9' -0"	10' -0"	12' -0"	14' -0"	16' -0"	18' -0"	20' -0"	22' -0"	24' -0"	26' -0"	28' -0"	30' -0"
20	30	30	30	30	30	30	30	30	30	28	26	24
25	30	30	30	30	30	30	29	26	24	22	21	19
30	30	30	30	30	30	27	24	22	20	18	17	16
35	30	30	30	30	26	23	21	19	17	16	15	14
40	30	30	30	26	23	20	18	16	15	14	13	12
45	30	30	27	23	20	18	16	14	13	12	11	10
50	30	29	24	21	18	16	14	13	12	11	10	9
55	29	26	22	19	16	14	13	12	11	10	9	8
60	27	24	20	17	15	13	12	11	10	9	8	8
65	25	22	18	16	14	12	11	10	9	8	8	7

4000 psi Concrete, using 1-1/4" O.D. flat washer

711 lbs. per anchor allowable load

Design Wind Load (psf)	Maximum on-center spacing (inches)											
	Opening Width (ft.-in.)											
	9' -0"	10' -0"	12' -0"	14' -0"	16' -0"	18' -0"	20' -0"	22' -0"	24' -0"	26' -0"	28' -0"	30' -0"
20	30	30	30	30	30	30	30	30	30	30	28	28
25	30	30	30	30	30	30	30	29	28	26	24	22
30	30	30	30	30	30	29	28	25	23	21	20	18
35	30	30	30	30	28	27	24	22	20	18	17	16
40	30	30	30	28	26	23	21	19	17	16	15	14
45	30	30	29	27	23	21	18	17	15	14	13	12
50	30	30	28	24	21	18	17	15	14	13	12	11
55	30	29	25	22	19	17	15	14	12	11	11	10
60	29	28	23	20	17	15	14	12	11	10	10	9
65	28	26	21	18	16	14	13	11	10	10	9	8

Notes:

1. In all instances, 2x6 is Southern Pine
2. Wood jamb can be counter bored up to 3/8" deep to provide flush mounting.
3. See figure on second page for spacing details and other information.

Mounting 2x6 to a building with concrete walls/jamb
3/8" Diameter Concrete Wedge Anchor w/ 1-3/8" O.D Flat Washer
(Includes Wej-It Ankr-Tite CCAT and ITW Red Head TruBolt)
Min. Embedment 2-1/2", Min. Edge Distance 2-1/2", Min. Spacing 6"

2500 psi Concrete, using 1-3/8" O.D. flat washer
831 lbs. per anchor allowable load

Design Wind Load (psf)	Maximum on-center spacing (inches)											
	Opening Width (ft.-in.)											
	9' -0"	10' -0"	12' -0"	14' -0"	16' -0"	18' -0"	20' -0"	22' -0"	24' -0"	26' -0"	28' -0"	30' -0"
20	30	30	30	30	30	30	30	30	30	30	28	28
25	30	30	30	30	30	30	30	29	28	26	25	25
30	30	30	30	30	30	29	28	26	25	24	23	22
35	30	30	30	30	28	27	25	24	23	21	20	18
40	30	30	30	28	27	25	24	22	20	19	17	16
45	30	30	29	27	25	24	22	20	18	17	15	14
50	30	30	28	25	24	22	19	18	16	15	14	13
55	30	29	26	24	22	20	18	16	15	13	12	12
60	29	28	25	23	20	18	16	15	13	12	11	11
65	28	26	24	21	19	17	15	13	12	11	10	10

3000 psi Concrete, using 1-3/8" O.D. flat washer
911 lbs. per anchor allowable load

Design Wind Load (psf)	Maximum on-center spacing (inches)											
	Opening Width (ft.-in.)											
	9' -0"	10' -0"	12' -0"	14' -0"	16' -0"	18' -0"	20' -0"	22' -0"	24' -0"	26' -0"	28' -0"	30' -0"
20	30	30	30	30	30	30	30	30	30	30	28	28
25	30	30	30	30	30	30	30	29	28	26	25	25
30	30	30	30	30	30	29	28	26	25	24	23	22
35	30	30	30	30	28	27	25	24	23	22	21	20
40	30	30	30	28	27	25	24	23	22	21	19	18
45	30	30	29	27	25	24	22	21	20	18	17	16
50	30	30	28	25	24	22	21	19	18	16	15	14
55	30	29	26	24	23	21	19	18	16	15	14	13
60	29	28	25	23	22	20	18	16	15	14	13	12
65	28	26	24	22	21	18	16	15	14	12	12	11

4000 psi Concrete, using 1-3/8" O.D. flat washer
960 lbs. per anchor allowable load

Design Wind Load (psf)	Maximum on-center spacing (inches)											
	Opening Width (ft.-in.)											
	9' -0"	10' -0"	12' -0"	14' -0"	16' -0"	18' -0"	20' -0"	22' -0"	24' -0"	26' -0"	28' -0"	30' -0"
20	30	30	30	30	30	30	30	30	30	30	28	28
25	30	30	30	30	30	30	30	29	28	26	25	25
30	30	30	30	30	30	29	28	26	25	24	23	22
35	30	30	30	30	28	27	25	24	23	22	21	21
40	30	30	30	28	27	25	24	23	22	21	20	19
45	30	30	29	27	25	24	22	21	20	19	18	17
50	30	30	28	25	24	22	21	20	19	17	16	15
55	30	29	26	24	23	21	20	19	17	16	14	13
60	29	28	25	23	22	20	19	17	16	14	13	12
65	28	26	24	22	21	19	17	16	14	13	12	11

Notes:

1. In all instances, 2x6 is Southern Pine
2. Wood jamb can be counter bored up to 3/8" deep to provide flush mounting.
3. See figure on second page for spacing details and other information.

Mounting 2x6 to a building with concrete walls/jamb
3/8" Diameter L-Hook Anchor Bolt w/ 1-1/2" O.D. Flat Washer cast-in-place
 Min. Embedment 3", Min. Edge Distance 3", Min. Spacing 9"

2500 psi Concrete, using 1-1/2" O.D. flat washer
872 lbs. per anchor allowable load

Design Wind Load (psf)	Maximum on-center spacing (inches)											
	Opening Width (ft.-in.)											
	9' -0"	10' -0"	12' -0"	14' -0"	16' -0"	18' -0"	20' -0"	22' -0"	24' -0"	26' -0"	28' -0"	30' -0"
20	30	30	30	30	30	30	30	30	30	30	28	28
25	30	30	30	30	30	30	30	29	28	26	25	25
30	30	30	30	30	30	29	28	26	25	24	23	22
35	30	30	30	30	28	27	25	24	23	22	21	19
40	30	30	30	28	27	25	24	23	21	20	18	17
45	30	30	29	27	25	24	22	21	19	17	16	15
50	30	30	28	25	24	22	20	19	17	16	14	13
55	30	29	26	24	23	21	19	17	15	14	13	12
60	29	28	25	23	21	19	17	15	14	13	12	11
65	28	26	24	22	20	17	16	14	13	12	11	10

3000 psi Concrete, using 1-1/2" O.D. flat washer
1047 lbs. per anchor allowable load

Design Wind Load (psf)	Maximum on-center spacing (inches)											
	Opening Width (ft.-in.)											
	9' -0"	10' -0"	12' -0"	14' -0"	16' -0"	18' -0"	20' -0"	22' -0"	24' -0"	26' -0"	28' -0"	30' -0"
20	30	30	30	30	30	30	30	30	30	30	28	28
25	30	30	30	30	30	30	30	29	28	26	25	25
30	30	30	30	30	30	29	28	26	25	24	23	22
35	30	30	30	30	28	27	25	24	23	22	21	21
40	30	30	30	28	27	25	24	23	22	21	20	19
45	30	30	29	27	25	24	22	21	20	20	19	18
50	30	30	28	25	24	22	21	20	19	19	17	16
55	30	29	26	24	23	21	20	19	18	17	16	15
60	29	28	25	23	22	20	19	18	17	16	14	13
65	28	26	24	22	21	20	19	17	16	14	13	12

4000 psi Concrete, using 1-1/2" O.D. flat washer
1142 lbs. per anchor allowable load

Design Wind Load (psf)	Maximum on-center spacing (inches)											
	Opening Width (ft.-in.)											
	9' -0"	10' -0"	12' -0"	14' -0"	16' -0"	18' -0"	20' -0"	22' -0"	24' -0"	26' -0"	28' -0"	30' -0"
20	30	30	30	30	30	30	30	30	30	30	28	28
25	30	30	30	30	30	30	30	29	28	26	25	25
30	30	30	30	30	30	29	28	26	25	24	23	22
35	30	30	30	30	28	27	25	24	23	22	21	21
40	30	30	30	28	27	25	24	23	22	21	20	19
45	30	30	29	27	25	24	22	21	20	20	19	18
50	30	30	28	25	24	22	21	20	19	19	18	17
55	30	29	26	24	23	21	20	19	18	18	17	16
60	29	28	25	23	22	20	19	18	18	17	16	15
65	28	26	24	22	21	20	19	18	17	16	15	14

Notes:

1. In all instances, 2x6 is Southern Pine
2. Wood jamb can be counter bored up to 3/8" deep to provide flush mounting.
3. L-Hook Anchor must conform to ASTM Standard A307.
4. See figure on second page for spacing details and other information.

Mounting 2x6 to a building with filled CMU walls/jamb
3/8" Diameter Heavy Duty Screw Anchor w/1" O.D. Flat Washer
 (Includes Simpson TitenHD)
 Min. Embedment 2-3/4", Min. Edge Distance 4", Min. Spacing 6"

Grout Filled CMU, using 1" O.D. flat washer
480 lbs. per anchor allowable load

Design Wind Load (psf)	Maximum on-center spacing (inches)											
	Opening Width (ft.-in.)											
	9' -0"	10' -0"	12' -0"	14' -0"	16' -0"	18' -0"	20' -0"	22' -0"	24' -0"	26' -0"	28' -0"	30' -0"
20	30	30	30	30	30	30	28	26	24	22	20	19
25	30	30	30	30	28	25	23	20	19	17	16	15
30	30	30	30	27	24	21	19	17	16	14	13	12
35	30	30	27	23	20	18	16	14	13	12	11	10
40	30	28	24	20	18	16	14	13	12	11	10	9
45	28	25	21	18	16	14	12	11	10	9	9	8
50	25	23	19	16	14	12	11	10	9	8	8	
55	23	20	17	14	13	11	10	9	8	8		
60	21	19	16	13	12	10	9	8	8			
65	19	17	14	12	11	9	8	8				

Notes:

1. In all instances, 2x6 is Southern Pine
2. Wood jamb can be counter bored up to 3/8" deep to provide flush mounting.
3. Anchor ratings from ICC-ES ESR-1056.
4. Filled CMU block must comply with ASTM C90, and grout minimum 2000 psi.
5. Anchors not to be installed within 1-1/2" of vertical joints in CMU. A 4" to 4-1/2" edge distance should satisfy this requirement.
6. See figure on second page for spacing details and other information.

DOOR STOP ALTERNATIVE TO 1 INCH OVERHANG OF JAMB

Supplement to Haas Door Texas Drawings

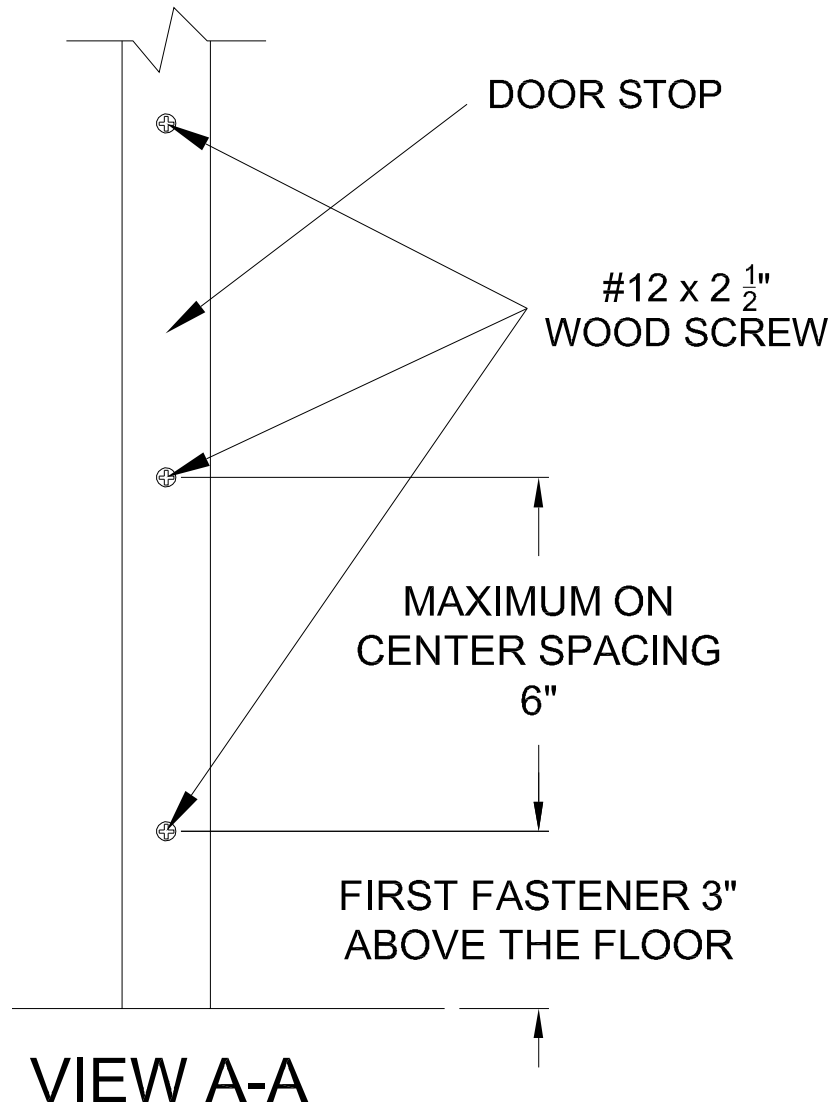
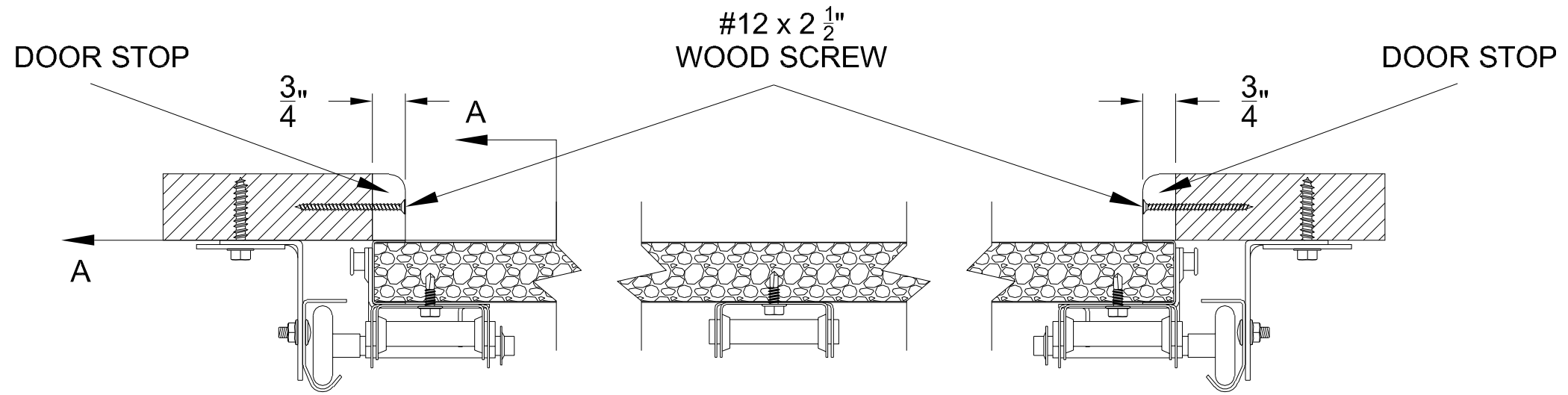

In the event the one inch over hang cannot be obtained, due to existing conditions or other factors, a one inch nominal ($\frac{3}{4}$ ") wooden door stop may be installed. The door stop must be attached to the jamb using a minimum #12 x 2 $\frac{1}{2}$ " wood screw on a maximum spacing of six inches. It is imperative that the door stop not split when being installed. If it does it must be replaced.

John E. Scates, P.E.
 2560 King Arthur Blvd. Ste 124-54
 Lewisville, Texas 75056
 Texas P.E. 56305/F2203

Professional Engineer seal provided only for verification of construction details.

	DESCRIPTION:		
	DOOR STOP ALTERNATIVE TO 1" OVERHANG OF JAMB		
	DRAWING NO.: DSAJ-030717	SHEET: 1 OF 1	REV.: A
DATE DRN: 3/7/17	DRAWN BY: MVS	MODEL(S):	