

NOTE: Track configuration above the door opening does not affect the wind load rating of the door.

This product has been tested per TAS202-94 for static air pressure.  
 This product has been tested per TAS201/203-94 for large missile impact and cyclic wind pressure.

Jamb bracket quantities shown are for use with grade 2 or better southern pine jambs.  
 Supporting structural element designs are to be the responsibility of the professional of record for the building or structure for the loads listed on this drawing.

Door Widths Up To	Design Pressures		End Stiles	Model Number						Impact Resistant
	+ psf	- psf		HT 5_80 SERIES		HT 5_70 SERIES		HT 5_10 SERIES HT 5_12 SERIES HT 5_14 SERIES HT 5_16 SERIES		
				Minimum Center Stiles	Hinges	Minimum Center Stiles	Hinges	Minimum Center Stiles	Hinges	
18'-2"	45.0	-50.0	Double	7	3	7	3	7	3	YES

This product is available in narrower sizes with the same PSF and constructed as shown.  
 This product is designed and sold by PSF. The AHJ or Engineer of Record is responsible for determining the PSF required for any given site.

Door Height	Total No. of Sections	Total # of Struts	Strut Configuration	Jamb Brkts/Side
6'-0"	3	5	SEE SHEET 3 OF 4	5
6'-0"	4	6		5
6'-3"	4	6		5
6'-6"	4	6		6
6'-9"	4	6		6
7'-0"	4	6		6
7'-3"	4	6		6
7'-6"	4	6		7
7'-6"	5	8		7
7'-9"	4	6		7
7'-9"	5	8		7
8'-0"	4	6		7
8'-0"	5	8		7

**NOTICE:**  
 These drawings are a supplement to the installation instructions for a standard door and only covers those procedures that vary from standard door installation. If these specific procedures are not followed, the door may not perform as designed.

John E. Scates, P.E.  
 2560 King Arthur Blvd. Ste 124-54  
 Lewisville, Texas 75056  
 Texas P.E. 56308/F2203

**IMPACT RESISTANT**

COMPLIES WITH IBC/IRC 2018 Professional Engineer seal provided only for verification of wind load construction details.

Maximum section height is 24 in.  
 Maximum door height is 20 ft.  
 All doors, even those above the tested height, are available with jamb brackets or commercial full angle. The quantity and dimensional location of the jamb brackets/track clips and the jamb mounting shown above should be maintained.

<p>320 Sycamore Wauseon, Ohio 43567 © Copyright 2014</p>	<b>DESCRIPTION:</b> 18' 2" HT 5000 ALUMINUM SERIES WIND LOAD SECTIONAL DOOR DESIGN PRESSURE +45.0/-50.0 PSF	
	<b>DRAWING NO.:</b> WLTI-5000-0218-08-45-50	<b>REV.:</b> A
	<b>DATE DRN:</b> 11/22/18	<b>DRAWN BY:</b> MVS
	<b>MODEL(S):</b> See Sheet 3	<b>REV. DATE:</b> 2/22/22
		<b>SHEET: 1 OF 4</b>

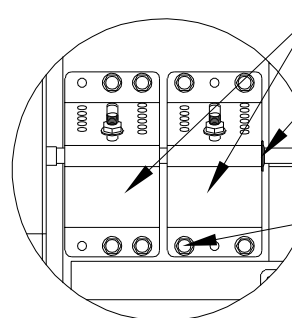

**DETAIL A**

ADJUSTABLE TOP FIXTURE 12 Ga  
 PUSH NUT 7/16" See DETAIL K for push nut placement  
 TEK SCREW 1/4" X 3/4" Hex Washer Head Self Drilling (4 per Bracket)

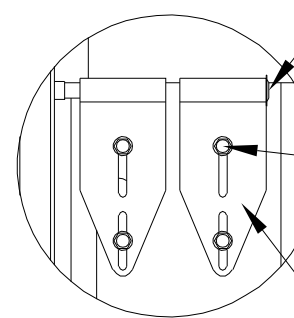

**LOW HEADROOM TOP BRACKET**

PUSH NUT 7/16" See DETAIL K for push nut placement.  
 TEK SCREW 1/4" X 3/4" Hex Washer Head Self Drilling (2 per Bracket)  
 LOW HEADROOM TOP BRACKET - 12 Ga

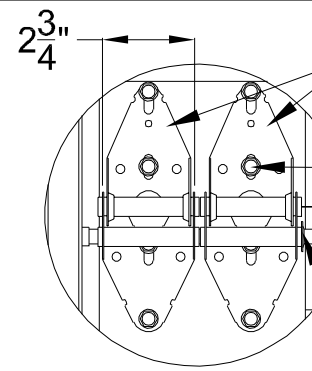

**DETAIL B**

END HINGE 14 Ga Galvanized Steel Minimum  
 TEK SCREW 1/4" X 3/4" Hex Washer Head Self Drilling (4 per Hinge)  
 PUSH NUT 7/16" See DETAIL K for push nut placement

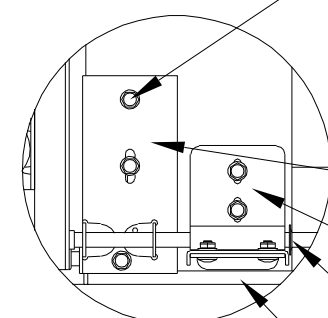

**DETAIL C**

TEK SCREW 1/4" X 3/4" Hex Washer Head Self Drilling (3 per Bottom & 2 per Adjustable Inner Bottom Brackets)  
 BOTTOM BRACKET 13 Ga Galvanized Steel  
 ADJUSTABLE INNER BOTTOM BRACKET  
 PUSH NUT 7/16" See DETAIL K for push nut placement.  
 BOTTOM SEAL

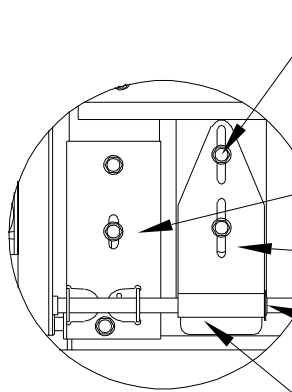

**ALTERNATE TO DETAIL C**

TEK SCREW 1/4" X 3/4" Hex Washer Head Self Drilling (3 per Bottom Bracket & 2 per Low Headroom Top Bracket)  
 BOTTOM BRACKET 13 Ga Galvanized Steel  
 LOW HEADROOM TOP BRACKET  
 PUSH NUT 7/16" See DETAIL K for push nut placement  
 BOTTOM SEAL

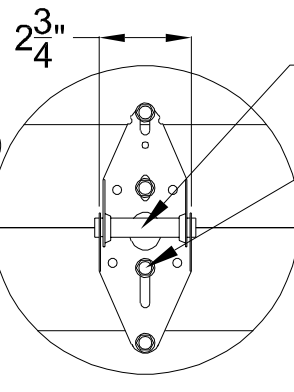

**DETAIL D**

INTERMEDIATE HINGE 18 or 14 Ga Galvanized Steel  
 TEK SCREW 1/4" X 3/4" Hex Washer Head Self Drilling (4 per Hinge)  
 NOTE: The location of the intermediate hinges is indicated by the toggle lock dimples at the top of each section.

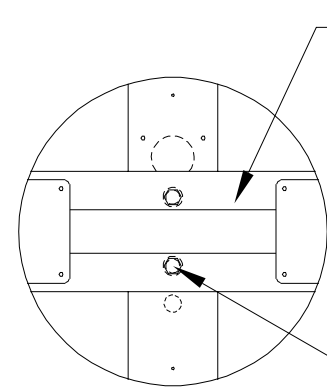

**DETAIL E**

3 1/2" x 5" E STRUT 18 Ga 70 KSI Minimum Galvanized Steel  
 TEK SCREW 1/4" X 3/4" Hex Washer Head Self Drilling (2 per End & Intermediate Stiles)

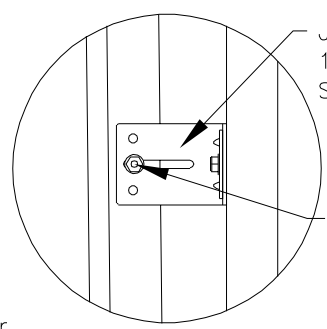

**DETAIL F**

JAMB BRACKET 12 Ga Galvanized Steel  
 BOLT & NUT 1/4-20 x 5/8" Carriage Bolt & 1/4-20 Hex Washer Nut (1 per Jamb Bracket)

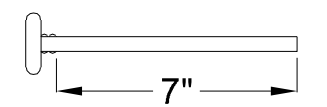

**ROLLER**

2" Diameter Nominal Eleven Ball Nylon or Ten Ball Steel with a Minimum Workable Shaft Length Shown.

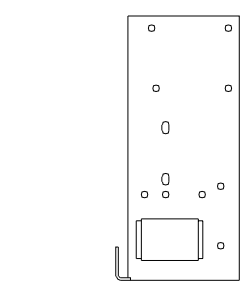

COMMERCIAL HEAVY DUTY For Standard, High & Vertical Lift With 3" Track and Double End Stiles

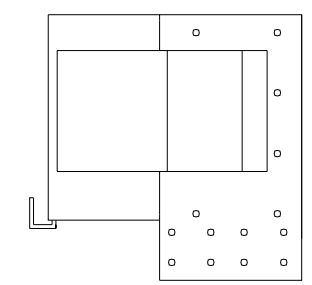

COMMERCIAL HEAVY DUTY For Low Headroom With 3" Track and Double End Stiles

**ALTERNATE BOTTOM BRACKETS**

NOTE: The bottom bracket tested (shown in DETAIL C) is the lightest bracket available.

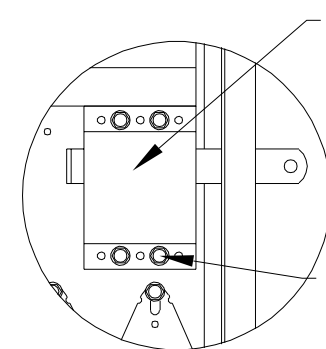

**DETAIL G**

SLIDE LOCK or LOCK BARS (not required with operator)  
 TEK SCREW 1/4" X 3/4" Hex Washer Head Self Drilling (4 per Slide Lock)

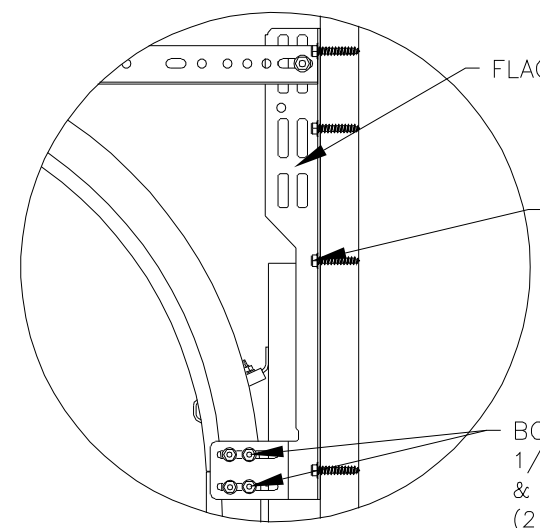

**DETAIL H**

FLAG BRACKET  
 BOLT 5/16 X 1 5/8" Lag Bolt (4 per Flag Bracket).  
 BOLT & NUT 1/4-20 X 5/8" Track Bolt & 1/4-20 Hex Washer Nut (2 for Horizontal & 2 for Vertical Track)

NOTE: Details on some views omitted for clarity.

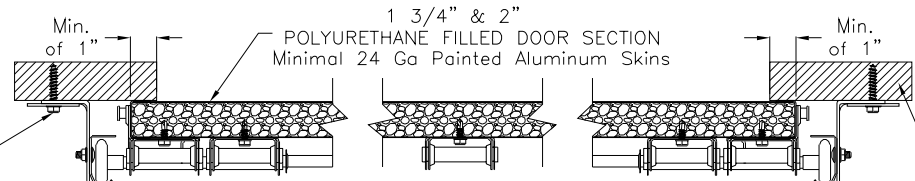

**DETAIL K**

Maximum 1/2" There should be a space of maximum 1/2" between the roller hub and the outside edge of the roller which is set by the push nut.

BOLT & WASHER 5/16" X 1 5/8" Lag Bolt & 2" O.D. x 7/16" I.D. Flat Washer  
 NOTE: Jamb bracket must be in direct contact with the 2x6 (No drywall allowed).  
 NOTE: A 5/8" minimal O.D. flat washer (not provided) is required for angle mount.  
 VERTICAL TRACK - 2" Nominal 13 Ga Galvanized Steel tested. 3" Nominal 13 Ga is also approved as an alternate.  
 WOOD JAMB  
 The vertical wood jamb fasteners may be counter sunk to provide a flat mounting surface. See jamb attachment details on sheet 3 for attaching jambs to the structure.

**IMPACT RESISTANT**

John E. Scates, P.E.  
 2560 King Arthur Blvd. Ste 124-54  
 Lewisville, Texas 75056  
 Texas P.E. 56308/F2203

Professional Engineer seal provided only for verification of wind load construction details.

<p>320 Sycamore          Wauseon, Ohio 43567          © Copyright 2014</p>	<b>DESCRIPTION:</b>		<b>REVISIONS</b> 1 DATE DRN: 11/22/18 DRAWN BY: MVS REV. DATE: 2/22/22
	18' 2" HT 5000 ALUMINUM SERIES WIND LOAD SECTIONAL DOOR DESIGN PRESSURE +45.0/-50.0 PSF		
	DRAWING NO.: WLTI-5000-0218-08-45-50		
	MODEL(S): See Sheet 3		
<b>SHEET: 2 OF 4</b>			

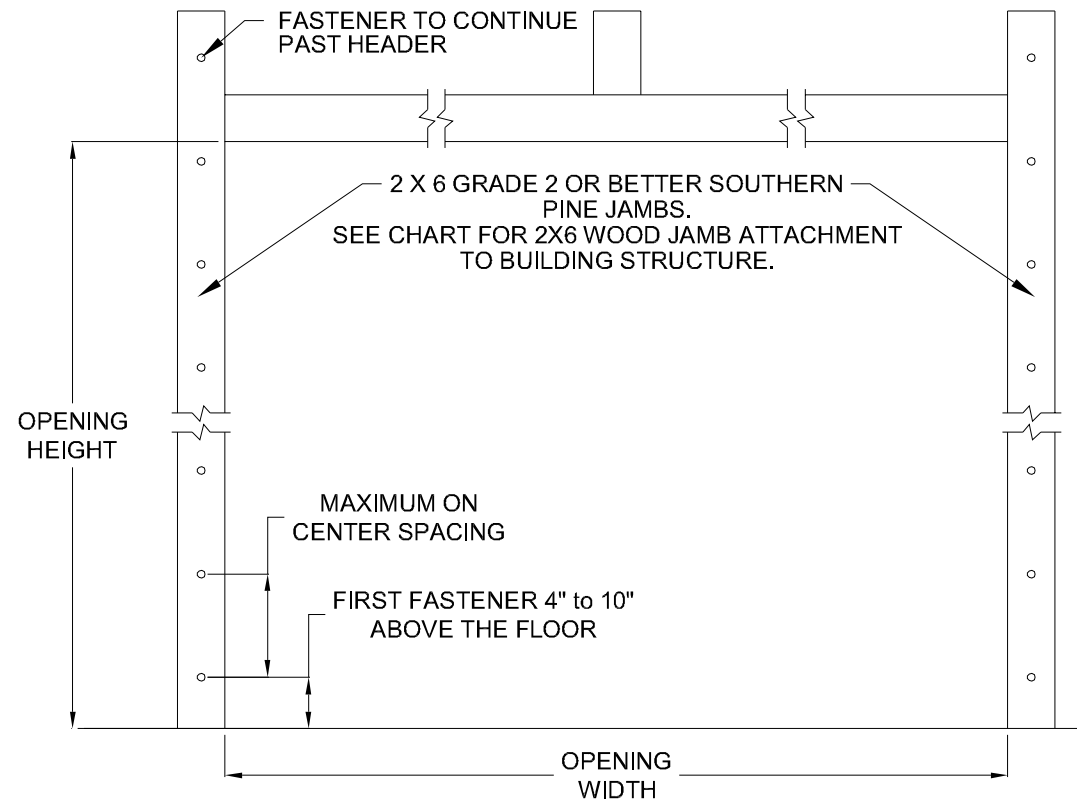

WOOD JAMB ATTACHMENT						
Building Structure	Fastener Type	Minimum Embedment	Minimum Edge Distance	Minimum on Center Spacing	Maximum on Center Spacing	Allowable Tension Load
Min. 2500 PSI to 4000 PSI Concrete	Tapcon + (PLUS) 1/4" w/ 1" OD washer	2"	2.50"	5.00"	16"	551
Southern Pine	3/8" Lag w/ 1 1/8" OD washer	1.50"	1.50"	1.50"	18"	620
Spruce Pine Fir	3/8" Lag w/ 1 1/8" OD washer	1.50"	1.50"	1.50"	14"	482

NOTE: 2X6 mounted to the wall must be Southern Pine Grade 2 or better.

## MODEL NUMBERS

MODEL NUMBERS AVAILABLE
HT 5 _10 SERIES
HT 5 _12 SERIES
HT 5 _14 SERIES
HT 5 _16 SERIES
HT 5 _70 SERIES
HT5 _80 SERIES

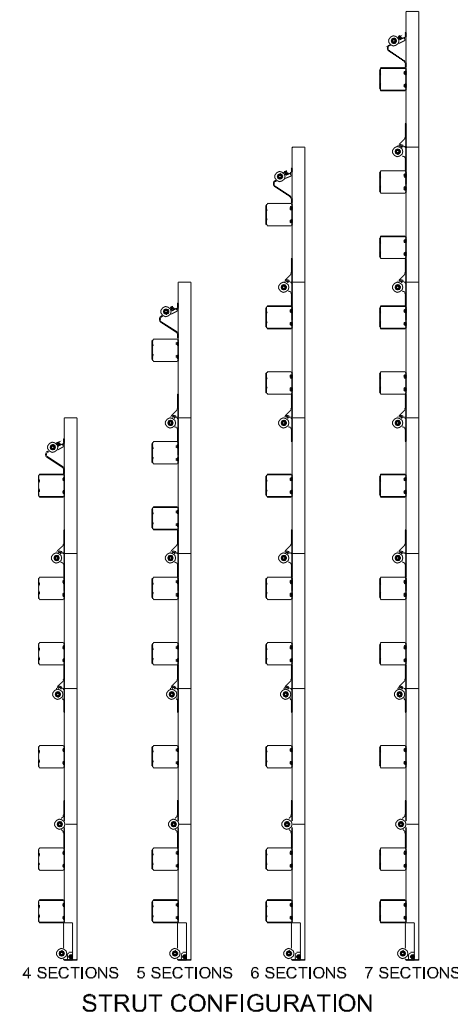

## IMPACT RESISTANT

John E. Scates, P.E.  
 2560 King Arthur Blvd. Ste 124-54  
 Lewisville, Texas 75056  
 Texas P.E. 56308/F2203

Professional Engineer seal provided only for verification of wind load construction details.



**DESCRIPTION:**  
 18' 2" HT 5000 ALUMINUM SERIES  
 WIND LOAD SECTIONAL DOOR  
 DESIGN PRESSURE +45.0/-50.0 PSF

**DRAWING NO.:** WLTI-5000-0218-08-45-50 **REV.** A

**DATE DRN:** 11/22/18 **DRAWN BY:** MVS **REV. DATE:** 2/22/22

**MODEL(S):** See Sheet 3 **SHEET:** 3 OF 4

320 Sycamore  
 Wauseon, Ohio 43567  
 © Copyright 2014

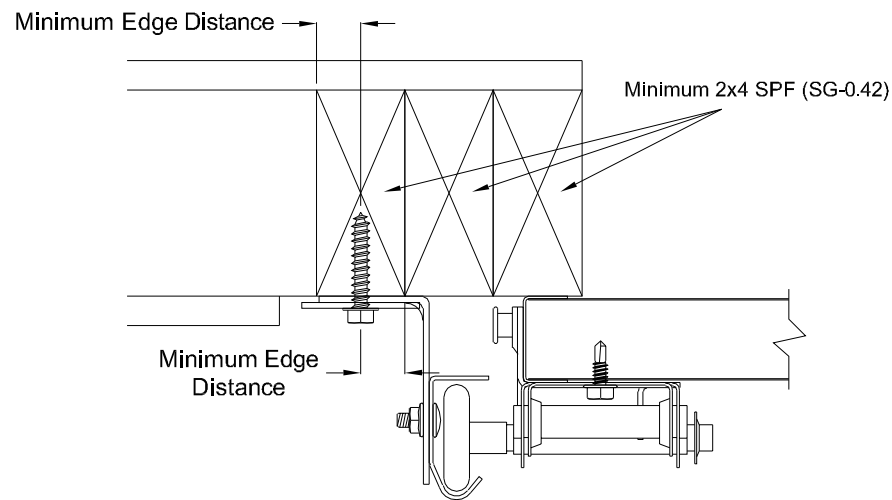

### Direct Wood Mounting Detail

Bracket Mount Shown, Reverse and Continuous Angle Mount Also Approved As Alternate.

439 lbs. per anchor allowable load

5/16" Dia. Lag Screw w/1-1/8" O.D. Flat Washer (shall conform to ANSI/ASME standard B18.2.1)

Minimum Screw Length: Spruce-Pine-Fur (SPF) - 2-1/2"  
Southern Pine - 1-5/8"

Minimum Edge Distance: 1/2"

Maximum on Center Spacing: 13"

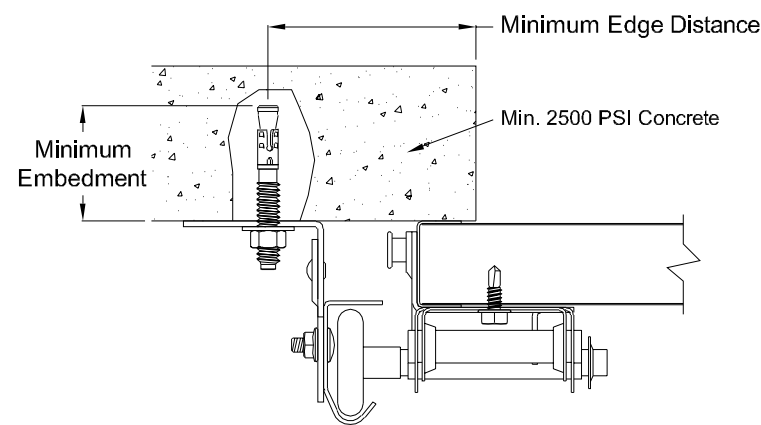

### Direct Concrete Mounting Detail

Continuous Angle Clip Mount Shown, Bracket and Reverse Continuous Angle Mount Also Approved As Alternate.

831 lbs. per anchor allowable load

3/8" Dia. Ankr-Tite CCAT w/1-1/8" O.D. Flat Washer (by Wej-It Fastening Systems)

Minimum Embedment: 2-5/8"

Minimum Edge Distance: 2-1/2"

Minimum on Center Spacing: 6"

Maximum on Center Spacing: 24"

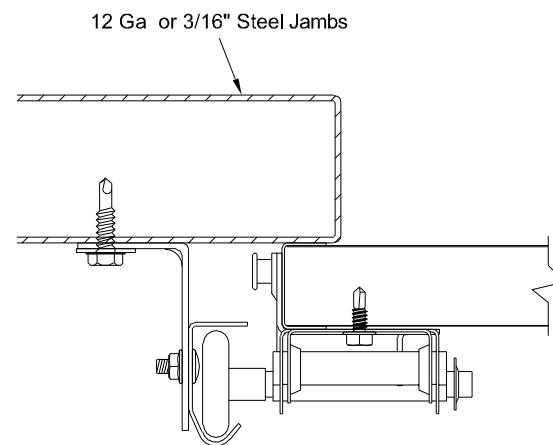

### Direct Steel Mounting Detail

Bracket Mount Shown, Reverse and Continuous Angle Mount Also Approved As Alternate.

232 lbs. per anchor allowable load - 12 Ga Steel

569 lbs. per anchor allowable load - 3/16" Steel

5/16"-12 Tek Self-Drilling Screw w/9/16" O.D. Flat Washer

12 Ga Maximum on Center Spacing: 7"

3/16" Maximum on Center Spacing: 17"

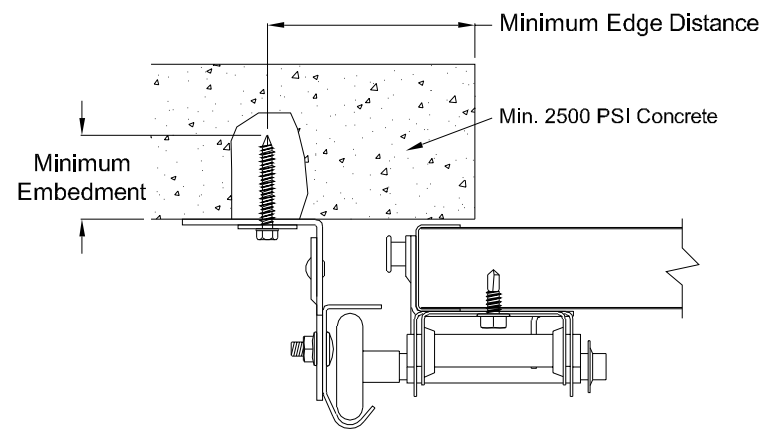

### Direct Concrete Mounting Detail

Continuous Angle Clip Mount Shown, Bracket and Reverse Continuous Angle Mount Also Approved As Alternate.

562 lbs. per anchor allowable load

1/4" Dia. Concrete Self-Tapping & Wedge Anchor w/1" O.D. Flat Washer (Includes Tapcon+ (by ITW),

Wedge-Bolt+ (by Powers Fasteners) & Red Head

TruBolt wedge anchor (by ITW))

Minimum Embedment: 2"

Minimum Edge Distance: 2-1/2"

Minimum on Center Spacing: 5"

Maximum on Center Spacing: 16"

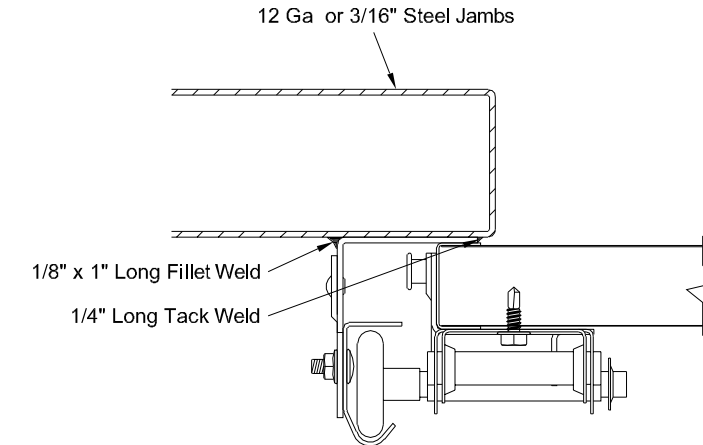

### Direct Steel Mounting Detail

Reverse Continuous Angle Clip Mount Shown, Continuous Angle Mount Also Approved As Alternate.

1272 lbs. per anchor allowable load

1/8" Nom. x 1" Long Fillet and 1/4" Long Tack Weld (E60xx Electrodes Min.)

Welds performed by a certified welder or inspected by a certified welding inspector to verify integrity of the welds.

Maximum on Center Spacing: Apply welds at each roller location not to exceed 24"

### IMPACT RESISTANT

John E. Scates, P.E.  
2560 King Arthur Blvd. Ste 124-54  
Lewisville, Texas 75056  
Texas P.E. 56308/F2203

Professional Engineer seal provided only for verification of wind load construction details.



**DESCRIPTION:**  
18' 2" HT 5000 ALUMINUM SERIES  
WIND LOAD SECTIONAL DOOR  
DESIGN PRESSURE +45.0/-50.0 PSF

**DRAWING NO.:** WLTI-5000-0218-08-45-50 **REV.** A

**DATE DRN:** 11/22/18 **DRAWN BY:** MVS **REV. DATE:** 2/22/22

**MODEL(S):** See Sheet 3 **SHEET:** 4 OF 4

320 Sycamore  
Wauseon, Ohio 43567  
© Copyright 2014