

NOTE: Track configuration above the door opening does not affect the wind load rating of the door.

This product has been evaluated per ANSI/DASMA 108 for static air pressure.
 This product has been evaluated per ANSI/DASMA 115 for large missile impact and cyclic wind pressure.

Jamb bracket quantities shown are for use with grade 2 or better southern pine jambs.
 Supporting structural elements are to be designed by a registered professional engineer for specific wind loads.

Door Widths Up To	Design Pressures		End Stiles	Model Number						Impact Resistant
	+ psf	- psf		HT 5_80 SERIES		HT 5_87 SERIES		HT 5_10 SERIES		
				Minimum Center Stiles	Minimum Center Hinges	Minimum Center Stiles	Minimum Center Hinges	Minimum Center Stiles	Minimum Center Hinges	
8'-2"	40.0	-45.0	Single	1	1	1	1	1	1	YES
9'-2"	40.0	-45.0	Single	1	1	1	1	1	1	YES

Door Height	Total No. of Sections	Total # of Struts (When lite section is the top section. If not see the notice at the right)	Jamb Brkts/ Side
6'-0"	3	4	3
6'-0"	4	5	3
6'-3"	4	5	3
6'-6"	4	5	4
6'-9"	4	5	4
7'-0"	4	5	4
7'-3"	4	5	4
7'-6"	4	5	4
7'-6"	5	6	4
7'-9"	4	5	4
7'-9"	5	6	4
8'-0"	4	5	4
8'-0"	5	6	4

NOTICE: These drawings are a supplement to the installation instructions for a standard door and only covers those procedures that vary from standard door installation. If these specific procedures are not followed, the door may not perform as designed.

NOTICE: The lite section of this door may be replaced with a section with another lite style or a solid section. In either case the strut and stile configuration should remain the same.

NOTICE: Only one lite section per door is permitted. The lite section can be used anywhere except for the bottom section. If the lite section is not the top section then the struts must be located as shown in the STRUT CONFIGURATION on sheet 3 of 4.

This product is available in narrower sizes with the same PSF and constructed as shown.
 This product is designed and sold by PSF. The AHJ or Engineer of Record is responsible for determining the PSF required for any given site.

Maximum section height is 24 in.
 Maximum door height is 20 ft.
 All doors, even those above the tested height, are available with jamb brackets or commercial full angle. The maximum spacing of the jamb brackets/track clips should be maintained.

IMPACT RESISTANT

COMPLIES WITH IBC/IRC 2018 Professional Engineer seal provided only for verification of wind load construction details.

John E. Scates, P.E.
 2560 King Arthur Blvd. Ste 124-54
 Lewisville, Texas 75056
 Texas P.E. 56308/F2203

DESCRIPTION:
 9' 2" HT 5000 ALUMINUM SERIES W/LITES
 WIND LOAD SECTIONAL DOOR
 DESIGN PRESSURE +40.0/-45.0 PSF

DRAWING NO.: WLTl-5000-0110-08-40-45L **REV.** A

DATE DRN: 11/17/18 **DRAWN BY:** MVS **REV. DATE:** 2/22/22

MODEL(S): See Sheet 3 **SHEET:** 1 OF 4

320 Sycamore
 Wauseon, Ohio 43567
 © Copyright 2014

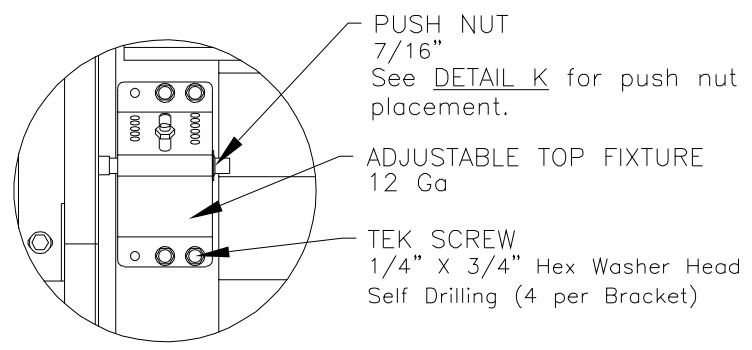

DETAIL A

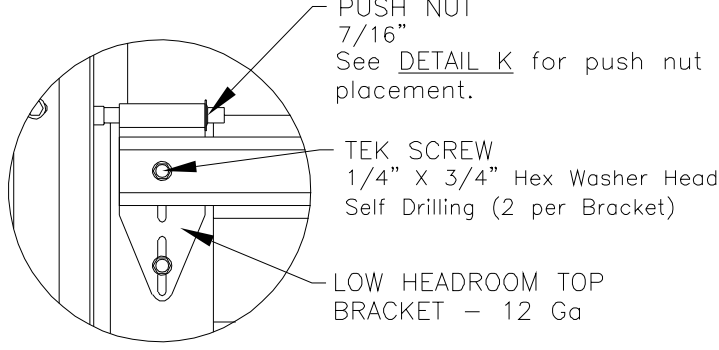

LOW HEADROOM TOP BRACKET

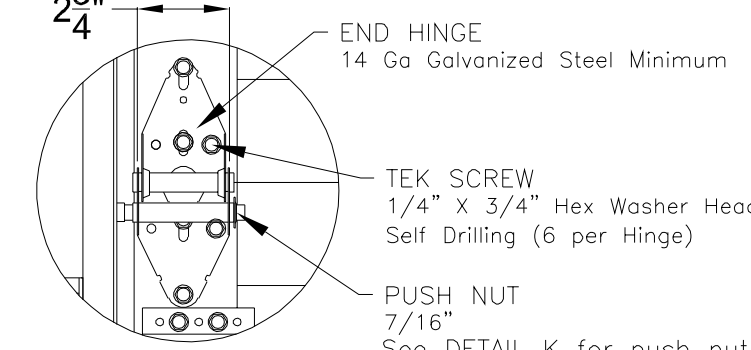

DETAIL B

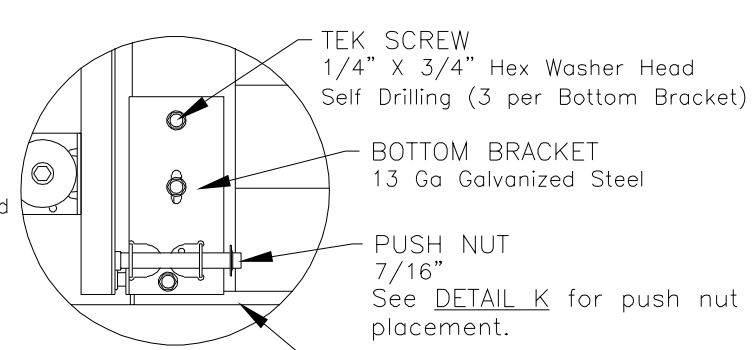

DETAIL C

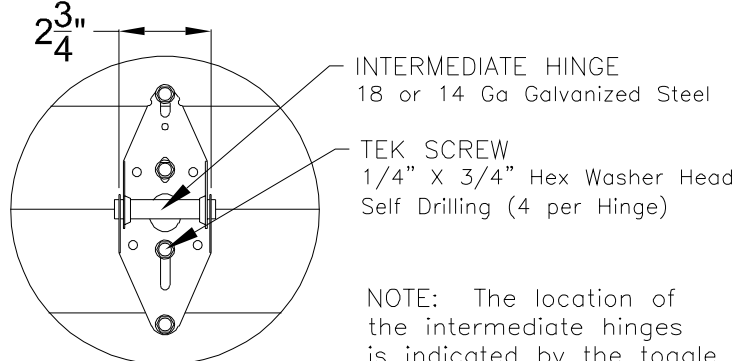

DETAIL D

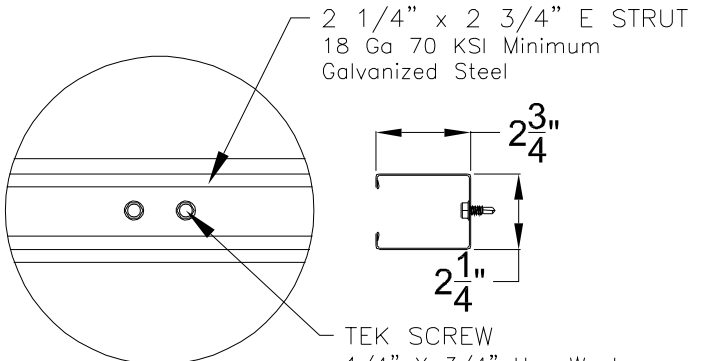

DETAIL E

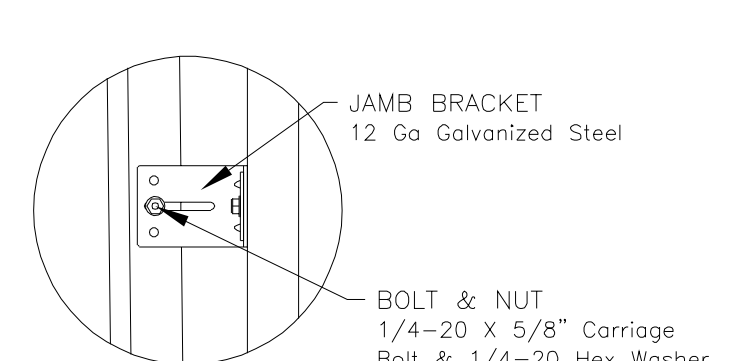

DETAIL F

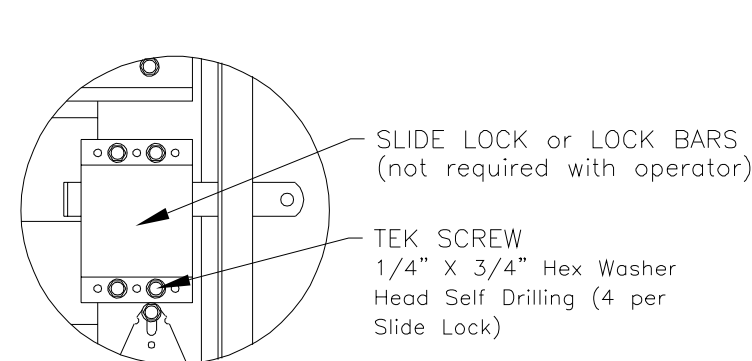

DETAIL G

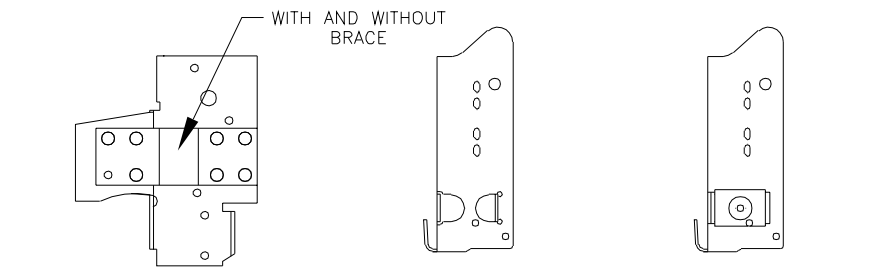

RESIDENTIAL & LIGHT COMMERCIAL For Low Headroom With 2" Track and Single End Stiles
 COMMERCIAL For Standard, High & Vertical Lift With 2" Track and Single End Stiles
 COMMERCIAL For Standard, High & Vertical Lift With 3" Track and Single End Stiles

ALTERNATE BOTTOM BRACKETS

NOTE: The bottom bracket tested (shown in DETAIL C) is the lightest bracket available.

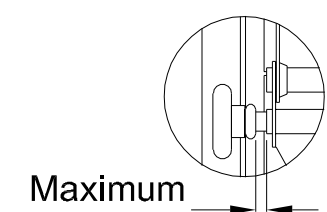

DETAIL K

There should be a space of maximum 1/2" between the roller hub and the outside edge of the roller holder which is set by the push nut.

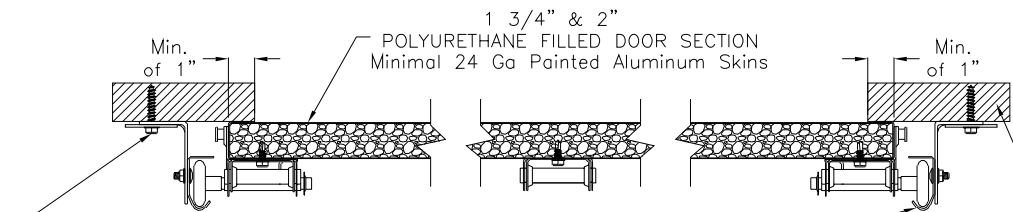

ROLLER

2" Diameter Nominal Eleven Ball Nylon or Ten Ball Steel with a Minimum Workable Shaft Length Shown.

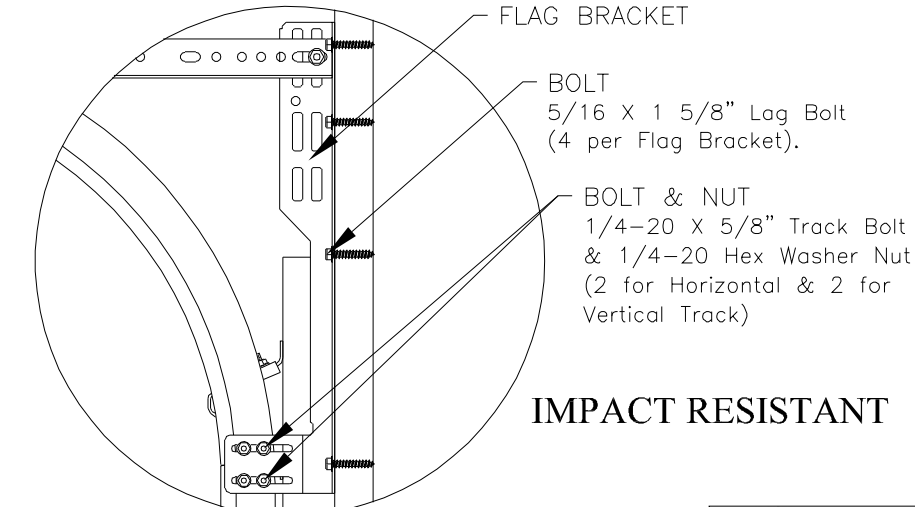

DETAIL H

IMPACT RESISTANT

NOTE: Details on some views omitted for clarity. Double end stiles and end hardware may be provided on wider or heavier doors.

John E. Scates, P.E.
 2560 King Arthur Blvd. Ste 124-54
 Lewisville, Texas 75056
 Texas P.E. 56308/F2203

Professional Engineer seal provided only for verification of wind load construction details.

<p>320 Sycamore Wauseon, Ohio 43567 © Copyright 2014</p>	DESCRIPTION:	
	9' 2" HT 5000 ALUMINUM SERIES W/LITES WIND LOAD SECTIONAL DOOR DESIGN PRESSURE +40.0/-45.0 PSF	
	DRAWING NO.: WLTI-5000-0110-08-40-45L	REV.: A
	DATE DRN: 11/17/18	DRAWN BY: MVS
MODEL(S): See Sheet 3	REV. DATE: 2/22/22	SHEET: 2 OF 4

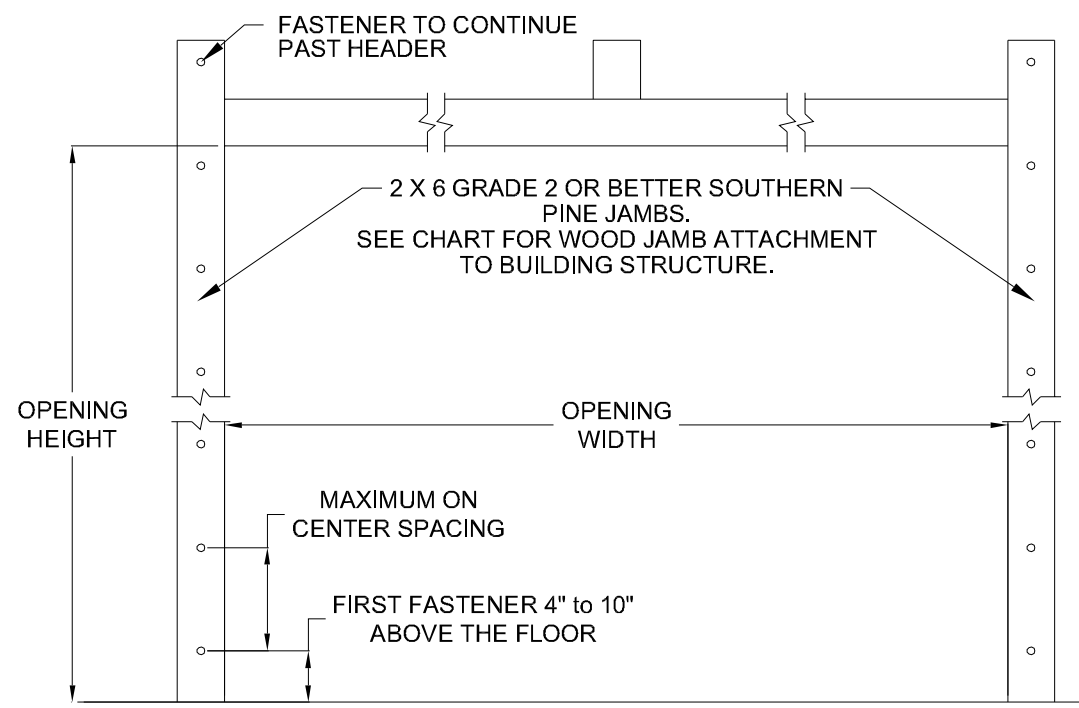

WOOD JAMB ATTACHMENT						
Building Structure	Fastener Type	Minimum Embedment	Minimum Edge Distance	Minimum on Center Spacing	Maximum on Center Spacing	Allowable Tension Load
Min. 2500 PSI to 4000 PSI Concrete	Tapcon + (PLUS) 1/4" w/ 1" OD washer	2"	2.50"	5.00"	24"	551
Southern Pine	3/8" Lag w/ 1 1/8" OD washer	1.50"	1.50"	1.50"	24"	620
Spruce Pine Fir	3/8" Lag w/ 1 1/8" OD washer	1.50"	1.50"	1.50"	24"	482

NOTE: 2X6 mounted to the wall must be Southern Pine Grade 2 or better.

MODEL NUMBERS AND IMPACT LITE OPTIONS

MODEL NUMBERS AVAILABLE	LITE OPTIONS AVAILABLE				
	CARRIAGE HOUSE	RANCH	STANDARD	LARGE COMMERCIAL 24 x 12	SMALL COMMERCIAL 24 x 6
HT 5 _10 SERIES			X		
HT5 _80 SERIES			X		
HT5 _87 SERIES			X		
			17 1/2" x 10 1/2"		
DAY LIGHT OPENING (DLO) - WIDE x TALL					

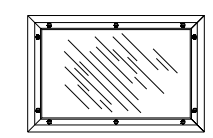
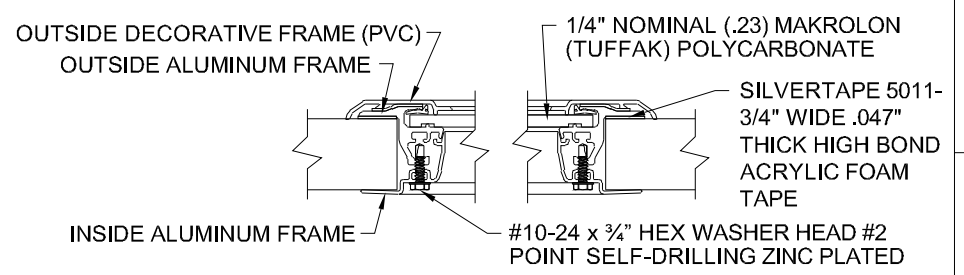

SCREW LOCATION - STANDARD LITE
NOTE: 10 SCREWS USED.

GLAZING DETAIL

NOTE: ALL GLAZING IS IMPACT RESISTANT MAKROLON (TUFFAK) GENERAL PURPOSE OR UV RESISTANT POLYCARBONATE WITH A 1/4 NOMINAL (.23) THICKNESS.

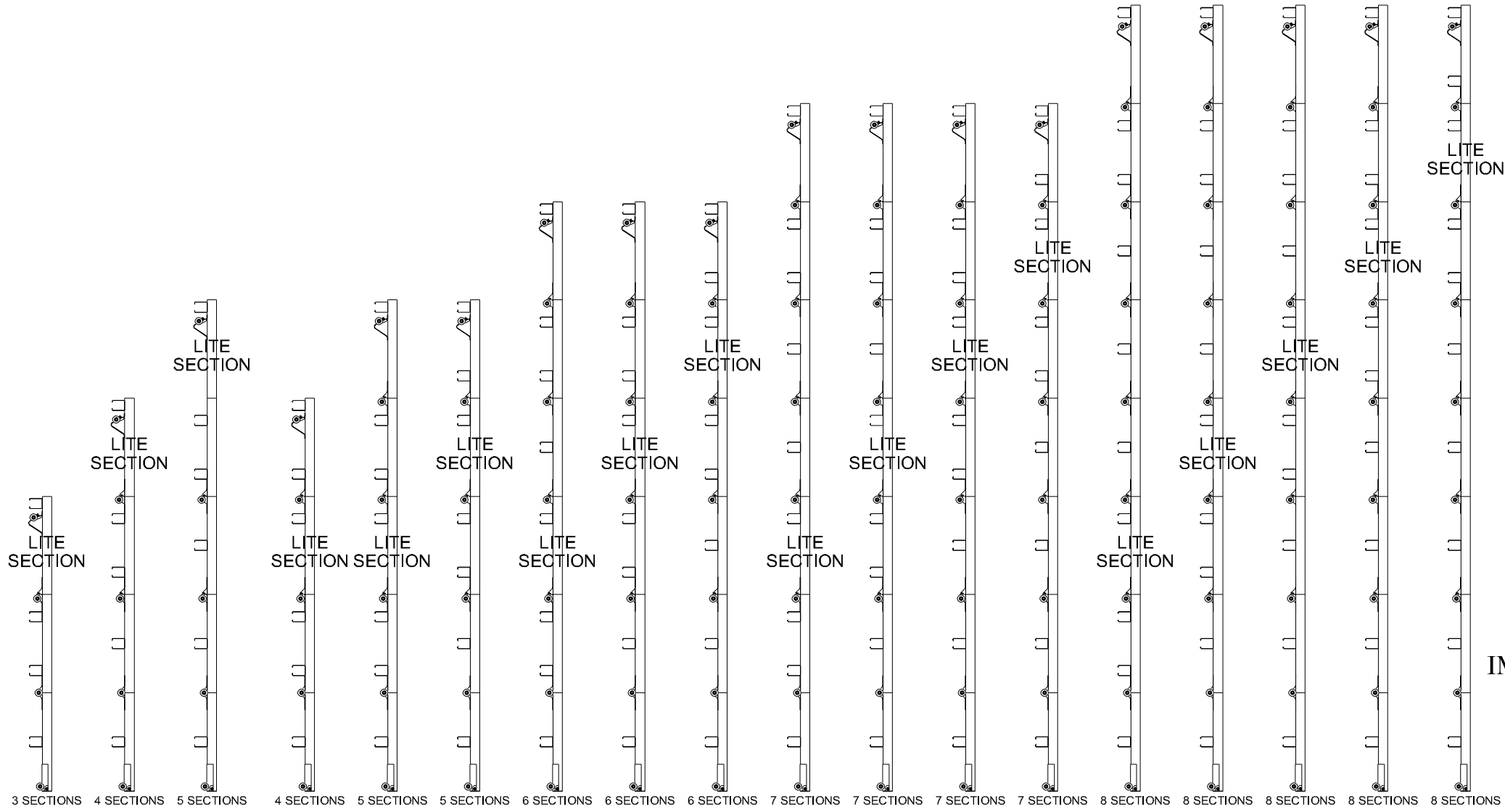

STRUT CONFIGURATION

IMPACT RESISTANT

John E. Scates, P.E.
2560 King Arthur Blvd. Ste 124-54
Lewisville, Texas 75056
Texas P.E. 56308/F2203

Professional Engineer seal provided only for verification of wind load construction details.



DESCRIPTION: 9' 2" HT 5000 ALUMINUM SERIES W/LITES WIND LOAD SECTIONAL DOOR DESIGN PRESSURE +40.0/-45.0 PSF			
DRAWING NO.: WLTl-5000-0110-08-40-45L	REV.: A		
DATE DRN: 11/17/18	DRAWN BY: MVS	REV. DATE: 2/22/22	
MODEL(S): See Sheet 3		SHEET: 3 OF 4	

320 Sycamore
Wauseon, Ohio 43567
© Copyright 2014

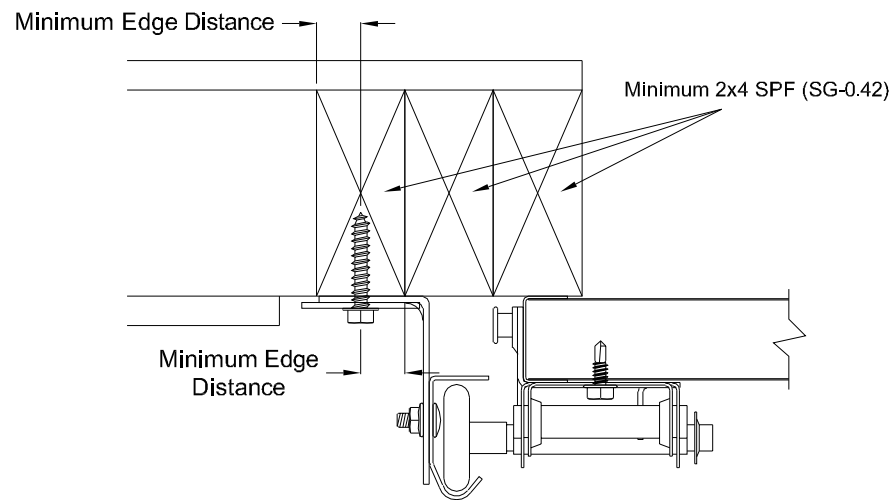

Direct Wood Mounting Detail

Bracket Mount Shown, Reverse and Continuous Angle Mount Also Approved As Alternate.

439 lbs. per anchor allowable load
 5/16" Dia. Lag Screw w/1-1/8" O.D. Flat Washer (shall conform to ANSI/ASME standard B18.2.1)
 Minimum Screw Length: Spruce-Pine-Fur (SPF) - 2-1/2"
 Southern Pine - 1-5/8"
 Minimum Edge Distance: 1/2"
 Maximum on Center Spacing: 24"

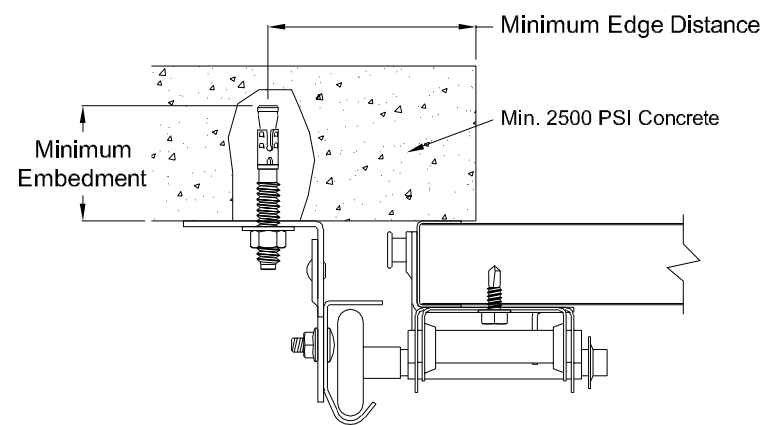

Direct Concrete Mounting Detail

Continuous Angle Clip Mount Shown, Bracket and Reverse Continuous Angle Mount Also Approved As Alternate.

831 lbs. per anchor allowable load
 3/8" Dia. Ankr-Tite CCAT w/1-1/8" O.D. Flat Washer (by Wej-It Fastening Systems)
 Minimum Embedment: 2-5/8"
 Minimum Edge Distance: 2-1/2"
 Minimum on Center Spacing: 6"
 Maximum on Center Spacing: 24"

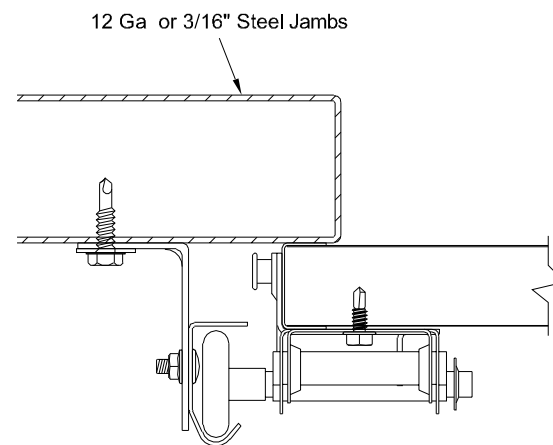

Direct Steel Mounting Detail

Bracket Mount Shown, Reverse and Continuous Angle Mount Also Approved As Alternate.

232 lbs. per anchor allowable load - 12 Ga Steel
 569 lbs. per anchor allowable load - 3/16" Ga Steel
 5/16"-12 Tek Self-Drilling Screw w/9/16" O.D. Flat Washer
 12 Ga Maximum on Center Spacing: 15"
 3/16" Maximum on Center Spacing: 24"

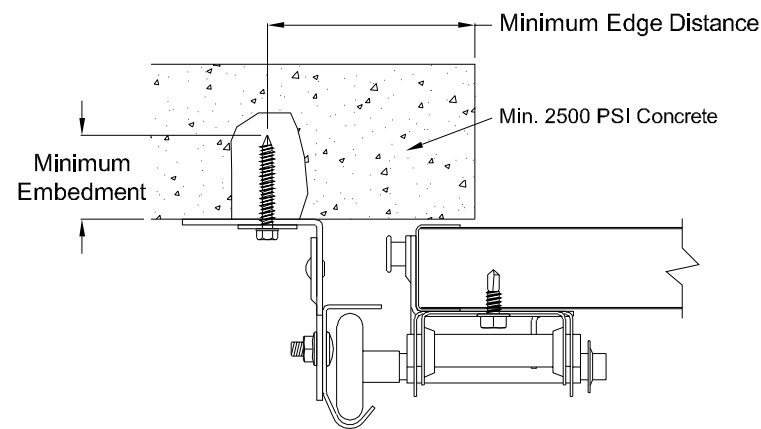

Direct Concrete Mounting Detail

Continuous Angle Clip Mount Shown, Bracket and Reverse Continuous Angle Mount Also Approved As Alternate.

562 lbs. per anchor allowable load
 1/4" Dia. Concrete Self-Tapping & Wedge Anchor w/1" O.D. Flat Washer (Includes Tapcon+ (by ITW), Wedge-Bolt+ (by Powers Fasteners) & Red Head TruBolt wedge anchor (by ITW))
 Minimum Embedment: 2"
 Minimum Edge Distance: 2-1/2"
 Minimum on Center Spacing: 5"
 Maximum on Center Spacing: 24"

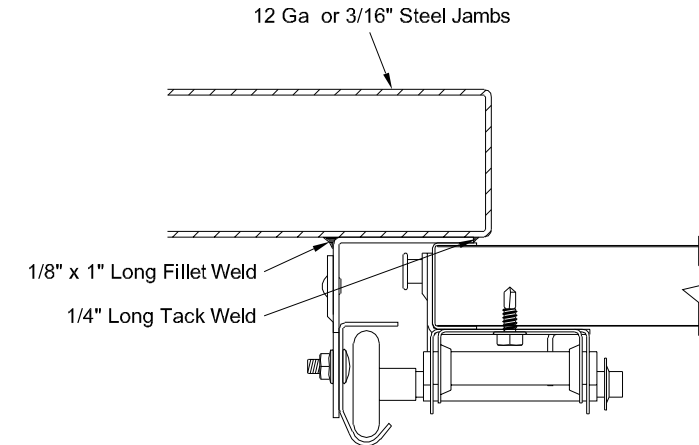

Direct Steel Mounting Detail

Reverse Continuous Angle Clip Mount Shown, Continuous Angle Mount Also Approved As Alternate.

1272 lbs. per anchor allowable load
 1/8" Nom. x 1" Long Fillet and 1/4" Long Tack Weld (E60xx Electrodes Min.)
 Welds performed by a certified welder or inspected by a certified welding inspector to verify integrity of the welds.
 Maximum on Center Spacing: Apply welds at each roller location not to exceed 24"

IMPACT RESISTANT

John E. Scates, P.E.
 2560 King Arthur Blvd. Ste 124-54
 Lewisville, Texas 75056
 Texas P.E. 56308/F2203

Professional Engineer seal provided only for verification of wind load construction details.



DESCRIPTION:
 9' 2" HT 5000 ALUMINUM SERIES W/LITES
 WIND LOAD SECTIONAL DOOR
 DESIGN PRESSURE +40.0/-45.0 PSF

DRAWING NO.: WLTI-5000-0110-08-40-45L **REV.** A

DATE DRN: 11/17/18 **DRAWN BY:** MVS **REV. DATE:** 2/22/22

MODEL(S): See Sheet 3 **SHEET:** 4 OF 4

320 Sycamore
 Wauseon, Ohio 43567
 © Copyright 2014