

THERMA-TRU[®] DOORS

Fiber-Classic[®] & Smooth-Star[®]

COMPOSITE EDGE OPAQUE FIBERGLASS DOUBLE DOOR w/ or w/out SIDELITES IN SWING/OUT SWING "IMPACT"

EVALUATED FOR USE IN THE STATE OF TEXAS

TDI DR-951

The Fiberglass Door system described herein complies with the 2018 International Residential Code (IRC), Sections R301 & R609 and the 2018 International Building Code (IBC), Sections 1404.13, 1609, 1709.5, 2403 and 2404 subject to the following conditions:

1. Anchors shall be as listed and spaced as shown in the details. Anchor embedment to base material shall be beyond wall dressing or stucco.
2. This system has been tested and evaluated as a large missile impact protective system for installation in areas that require wind borne debris protection. This product meets missile level "D" as defined in ASTM E 1996.
3. Allowable design pressure requirements must be equal to or less than the design pressure rating shown in the design pressure chart, sheet 1 of this drawing.
4. Conditions not covered by this drawing are subject to further engineering analysis.
5. Fiber-Classic and Smooth-Star Door & Sidelite panels require the use of "J" part numbers. These door panels must be stained or painted within six months of installation.

TABLE OF CONTENTS

SHEET #	DESCRIPTION
1	Typical Elevations, Design Pressures & General Notes
2	Door Panel Details
3	Sidelite Panel Details
4	Elevations
5	Horizontal & Vertical Cross Sections
6	Vertical Cross Sections (Thresholds)
7	Frame Anchoring
8	Hardware Details
9	Glazing Details
10	Components
11	Bill of Materials

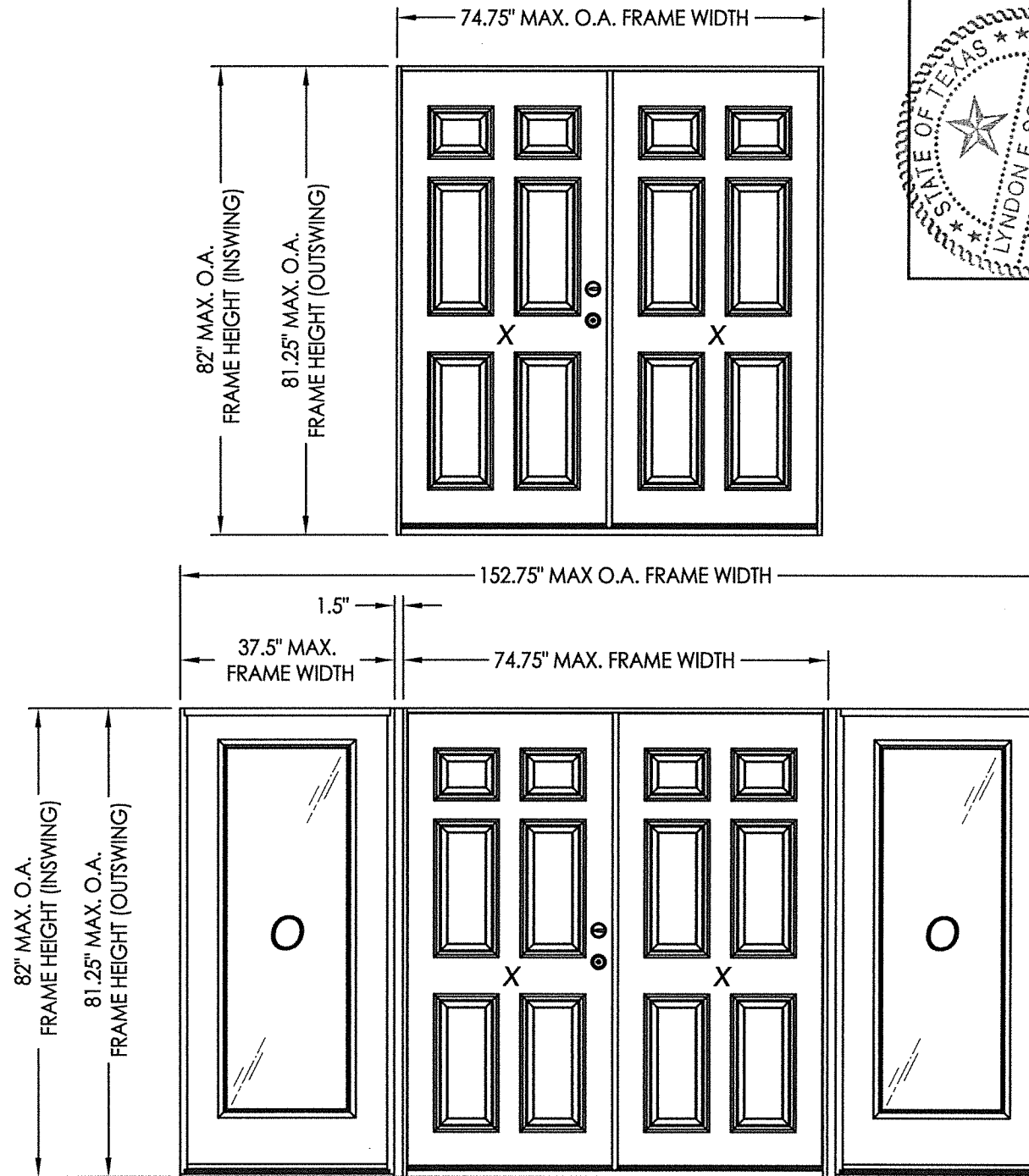

CONFIGURATION	DESIGN PRESSURE (PSF) IN SWING		DESIGN PRESSURE (PSF) OUT SWING	
	POSITIVE	NEGATIVE	POSITIVE	NEGATIVE
XX, OXXO	+50.0	-50.0	+50.0	-50.0

See Sheet 4 for Hardware Specifications

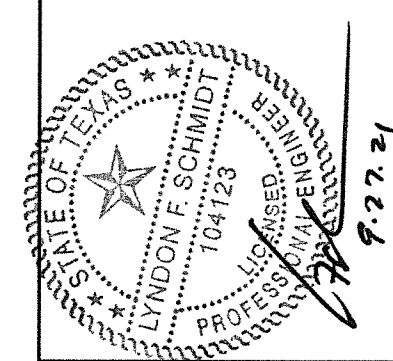

Documents Prepared By: Lyndon F. Schmidt, P.E.
TEXAS P.E. #104123

RW BUILDING CONSULTANTS, INC.
P.O. Box 230 Valrico FL 33595
Phone No.: 813.659.9197

CERTIFICATE OF REGISTRATION # F-11852

PRODUCT: THERMA-TRU FIBERGLASS DOOR

PART OR ASSEMBLY: TYPICAL ELEVATION, DESIGN PRESSURES & GENERAL NOTES

NO.	DATE	BY	REVISIONS
1	9/27/21	LFS	UPDATE TO 2018 IBC/IRC CODE

DATE: 10/24/17
SCALE: N.T.S.
DWG. BY: JK
CHK. BY: LFS
DRAWING NO.: TX-4707
SHEET 1 OF 11

Z:\Clients\Therma Tru PERMANENT\B - Texas Dept of Ins\TDI - DR 951 - 6'8 & 8'0 Opaque Comp Edge Impact (TX 4705 - 4710)\C - Drawings\TX-4705-7.dwg

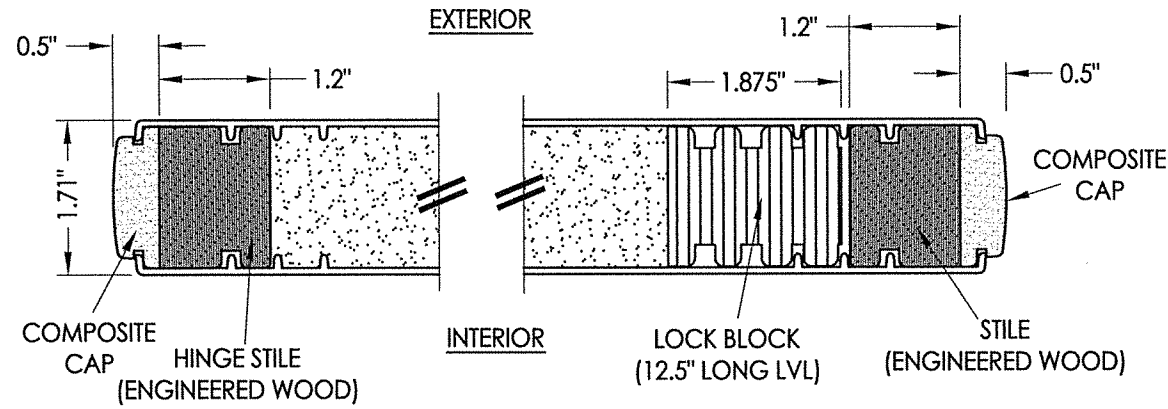

1
2 HORIZONTAL CROSS SECTION

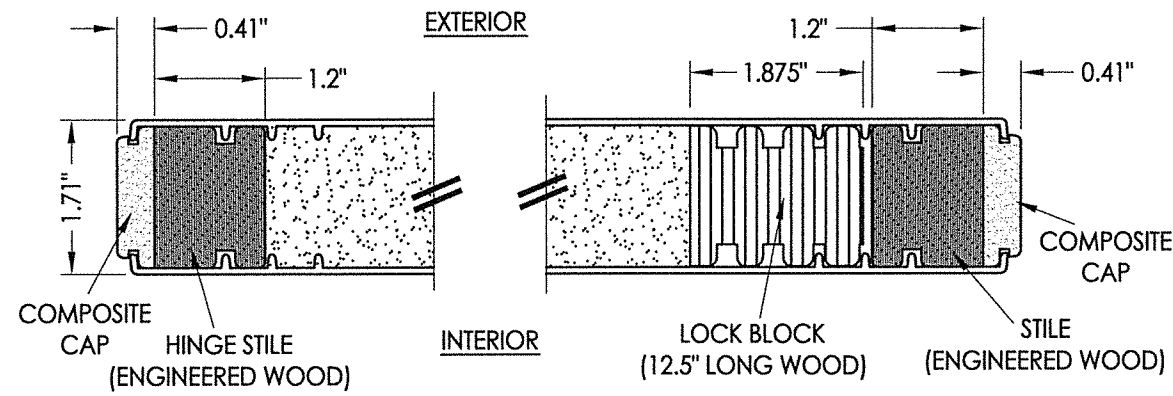

2
2 HORIZONTAL CROSS SECTION

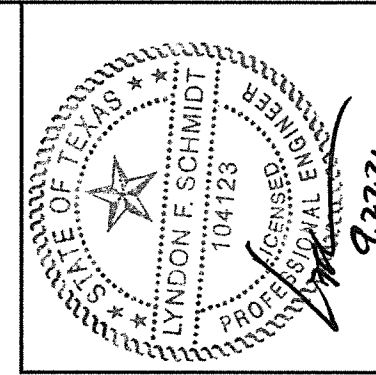

Documents Prepared By: Lyndon F. Schmidt, P.E.
TEXAS P.E. #104123

RW BUILDING CONSULTANTS, INC.
P.O. Box 230 Valrico FL 33595
Phone No.: 813.659.9197

CERTIFICATE OF REGISTRATION # F-11852

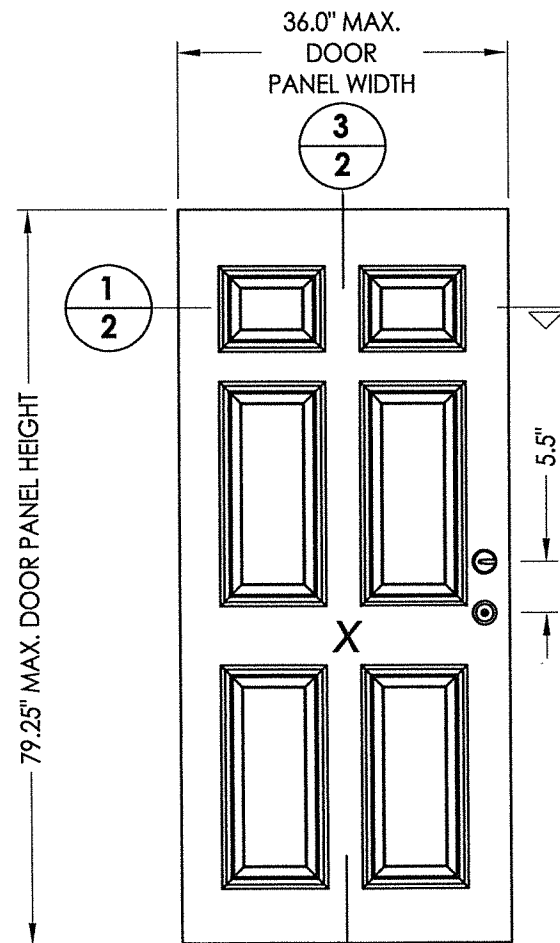

40 DOOR PANEL BOOK

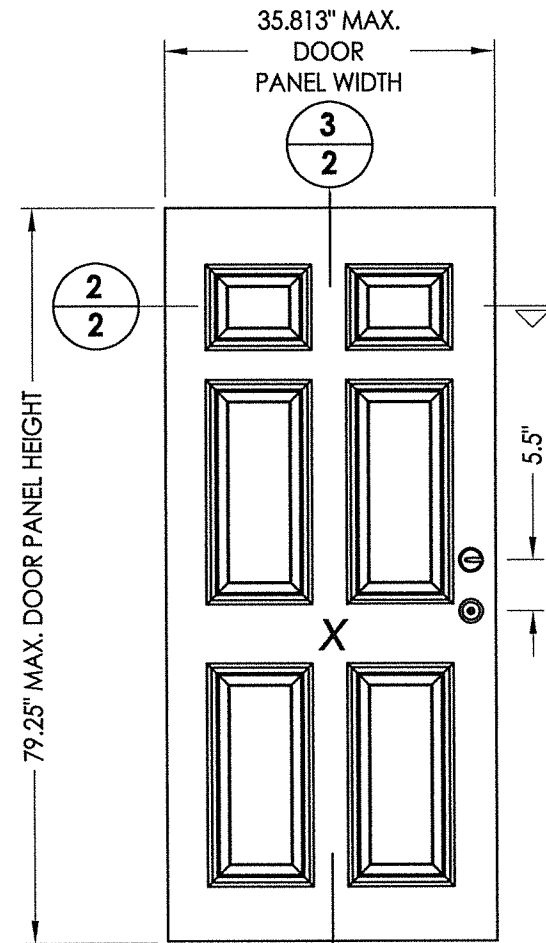

41 DOOR PANEL Hybrid Door

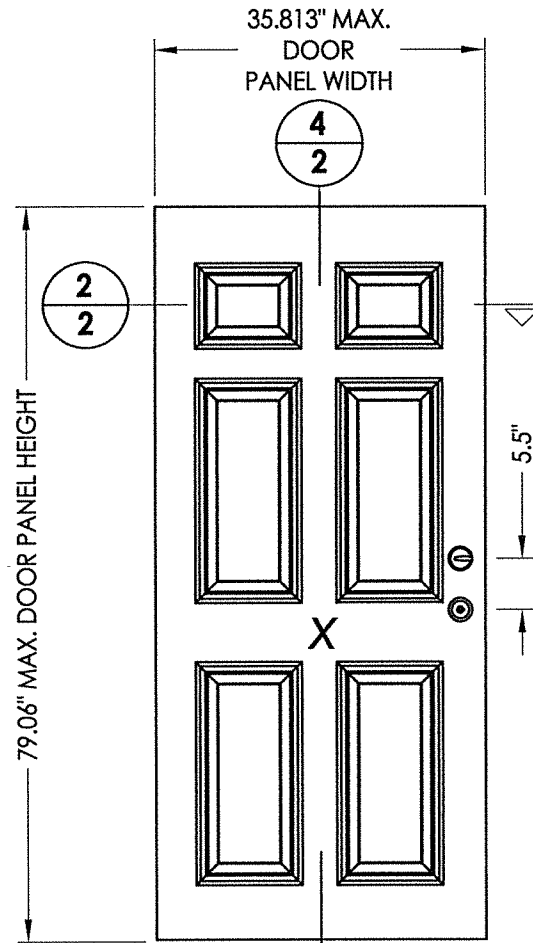

42 DOOR PANEL U1 Door

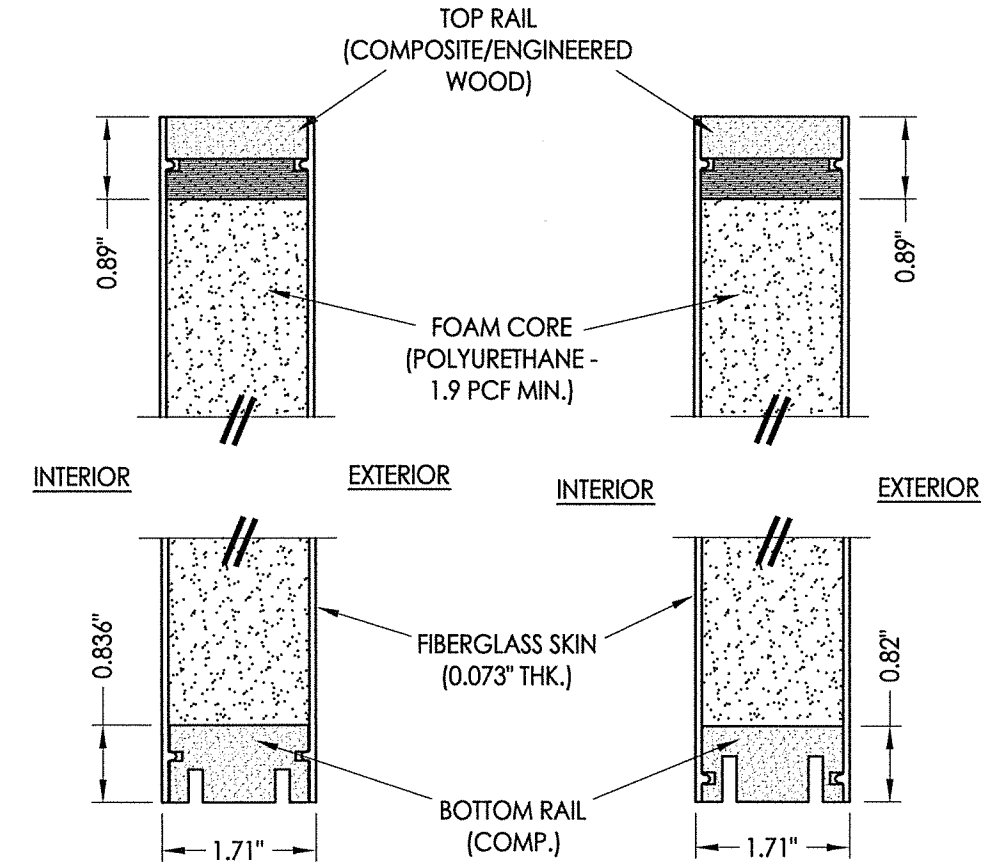

3
2 VERTICAL CROSS SECTION

4
2 VERTICAL CROSS SECTION

PRODUCT: THERMA-TRU FIBERGLASS DOOR	
PART OR ASSEMBLY: DOOR PANEL DETAILS	
NO.	DATE
1	9/27/21
UPDATE TO 2018 IBC/IRC CODE	
LFS	BY
REVISIONS	
DATE: 10/24/17	
SCALE: N.T.S.	
DWG. BY: JK	
CHK. BY: LFS	
DRAWING NO.: TX-4707	
SHEET 2 OF 11	

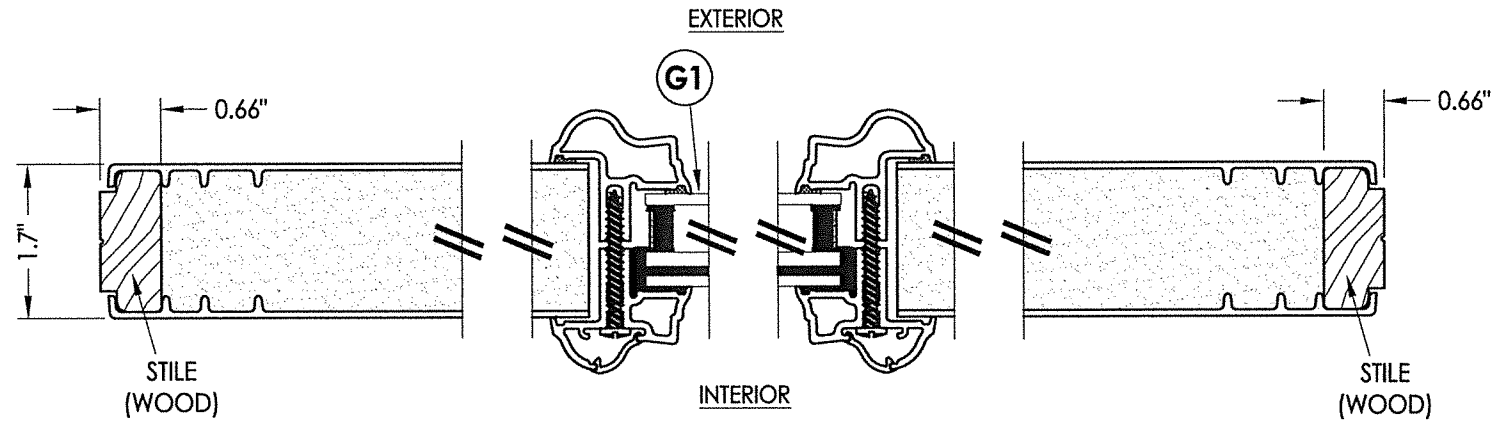

1
3 HORIZONTAL CROSS SECTION

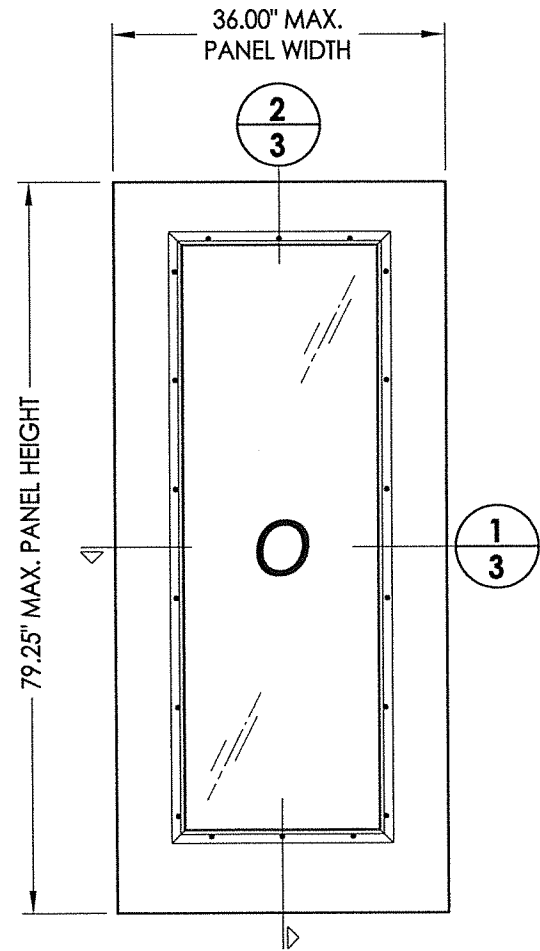

50 SIDELITE PANEL

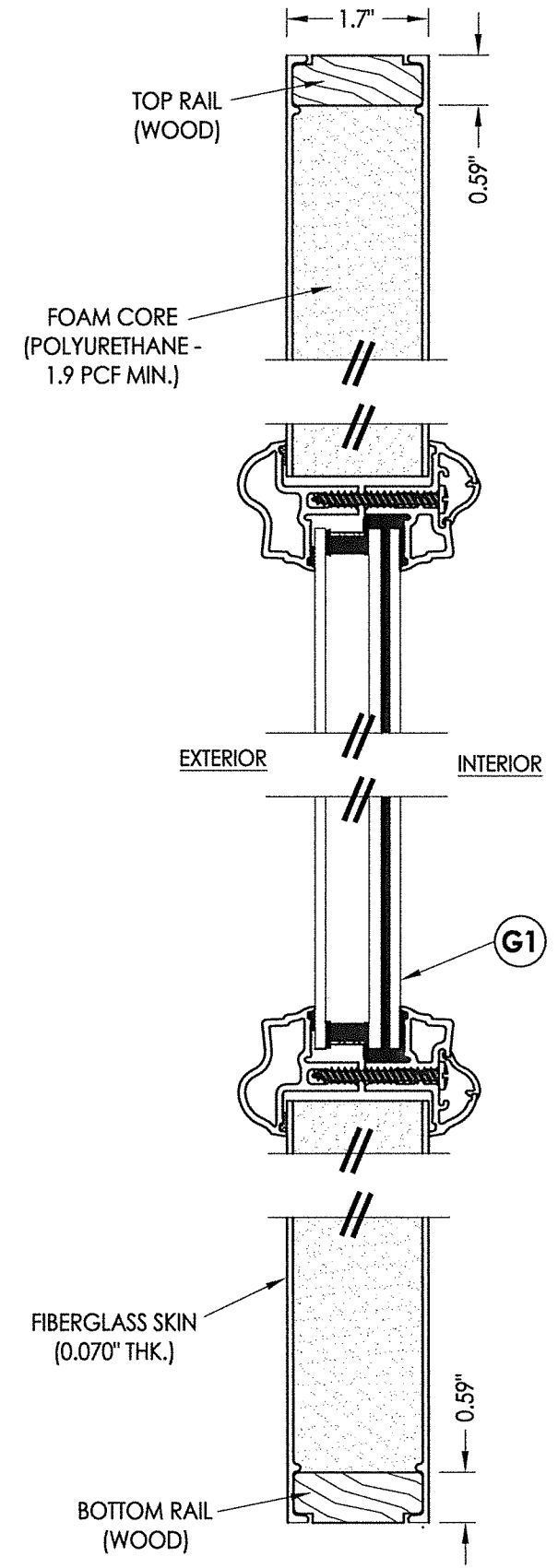

2
3 VERTICAL CROSS SECTION

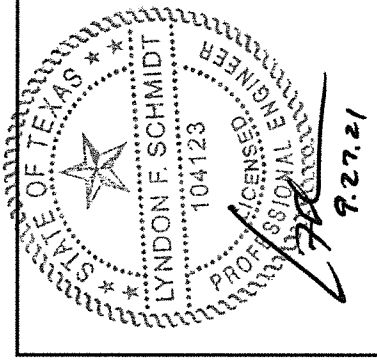

Documents Prepared By: Lyndon F. Schmidt, P.E.
TEXAS P.E. #104123

RW BUILDING CONSULTANTS, INC.
P.O. Box 230 Valrico FL 33595
Phone No.: 813.659.9197

CERTIFICATE OF REGISTRATION # F-11852

PRODUCT: THERMA-TRU
FIBERGLASS DOOR

PART OR ASSEMBLY: SIDELITE PANEL DETAILS

REVISIONS	
NO.	DATE
1	9/27/21
	UPDATE TO 2018 IBC/IRC CODE
	LFS
	BY

DATE: 10/24/17

SCALE: N.T.S.

DWG. BY: JK

CHK. BY: LFS

DRAWING NO.: TX-4707

SHEET 3 OF 11

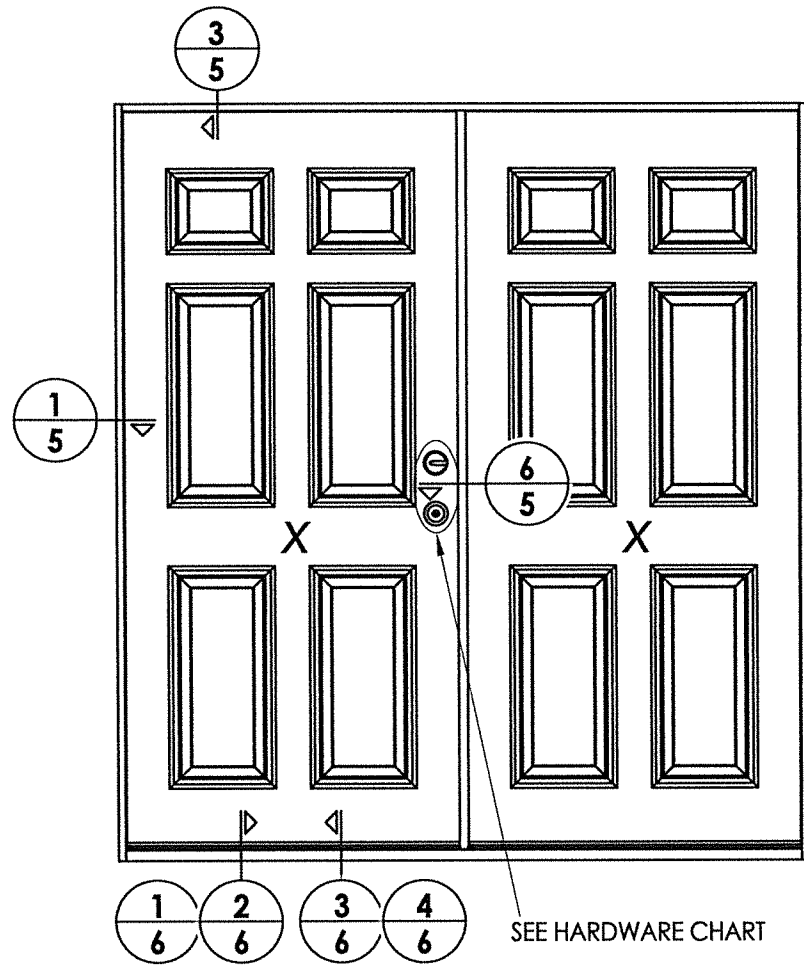

ELEVATION
XX

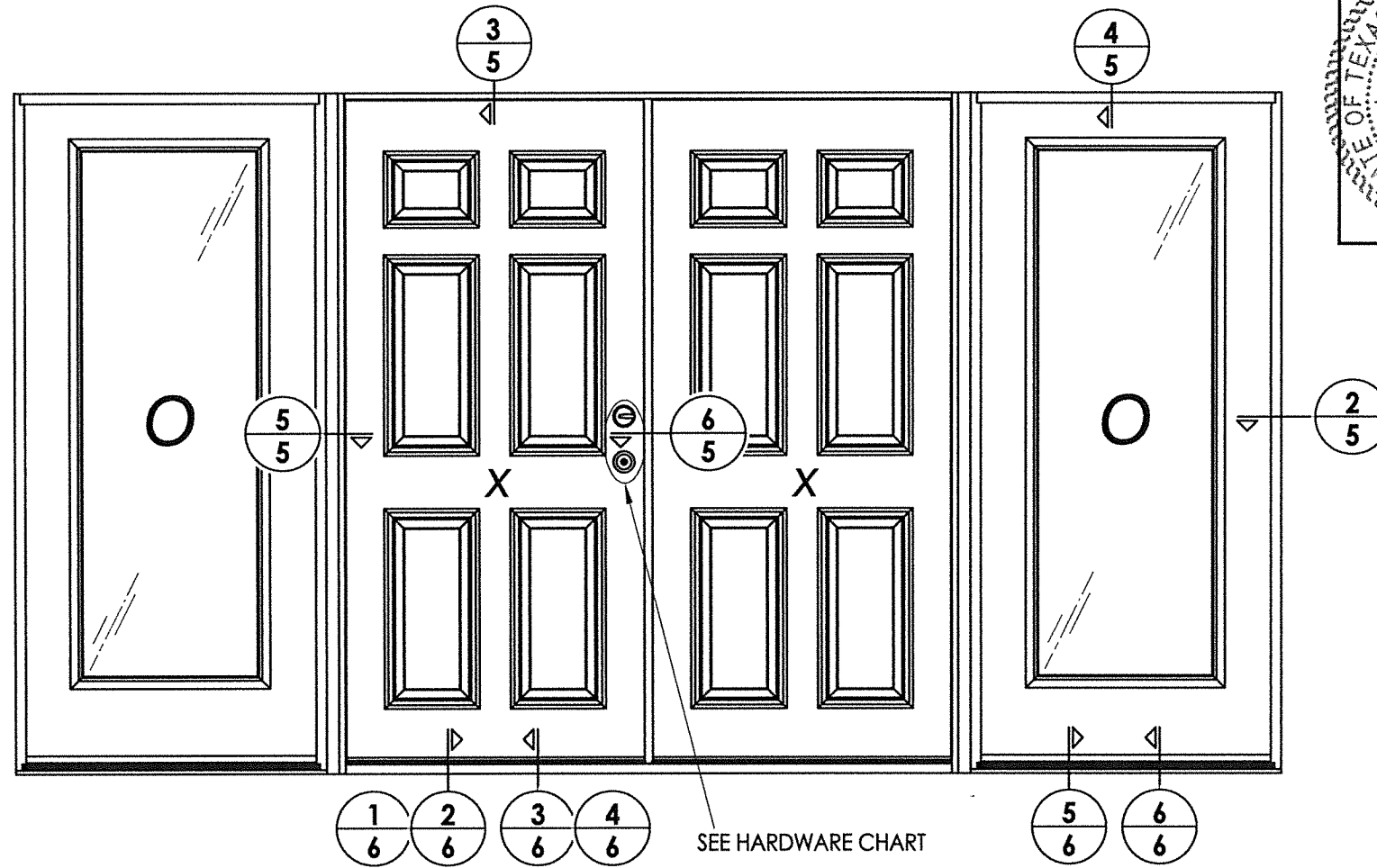

ELEVATION
OXXO

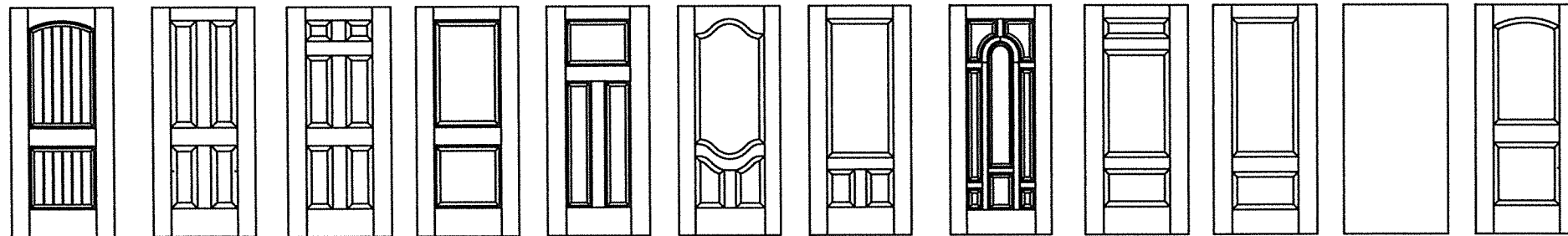

Fiber-Classic/Smooth-Star Door Panel Options
Panel options shown are for illustration and are representative only
(similar opaque panel configurations are allowed)

HARDWARE TABLE	
MANUFACTURER	MODEL
SCHLAGE	KNOB: F51 DEADBOLT: B60
KWIKSET	KNOB: SIGNATURE SERIES DEADBOLT: SIGNATURE SERIES (980)
HOPPE (THERMA-TRU)	MULTIPOINT : MPDGSB (3 pt. Manual Shootbolt)

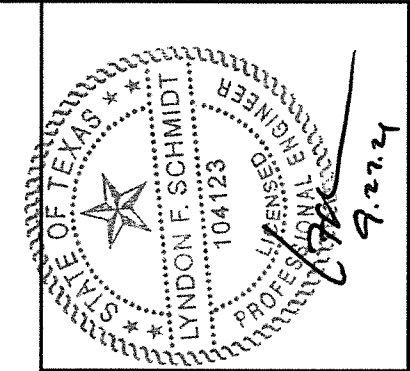

Documents Prepared By: Lyndon F. Schmidt, P.E.
TEXAS P.E. #104123

RW BUILDING CONSULTANTS, INC.
P.O. Box 230 Valrico FL 33595
Phone No.: 813.659.9197

CERTIFICATE OF REGISTRATION # F-11852

PRODUCT:	THERMA-TRU FIBERGLASS DOOR
PART OR ASSEMBLY:	ELEVATIONS
DATE:	10/24/17
SCALE:	N.T.S.
DWG. BY:	JK
CHK. BY:	LFS
DRAWING NO.:	TX-4707
SHEET	4 OF 11
REVISIONS	NO. DATE
	1 9/27/21 UPDATE TO 2018 IBC/IRC CODE
	LFS BY

Z:\Clients\Therma Tru PERMANENT\B - Texas Dept of Ins\TDI - DR 951 - 6'8 & 8'0 Opaque Comp Edge Impact (TX 4705 - 4710)\C - Drawings\TX-4705-7.dwg

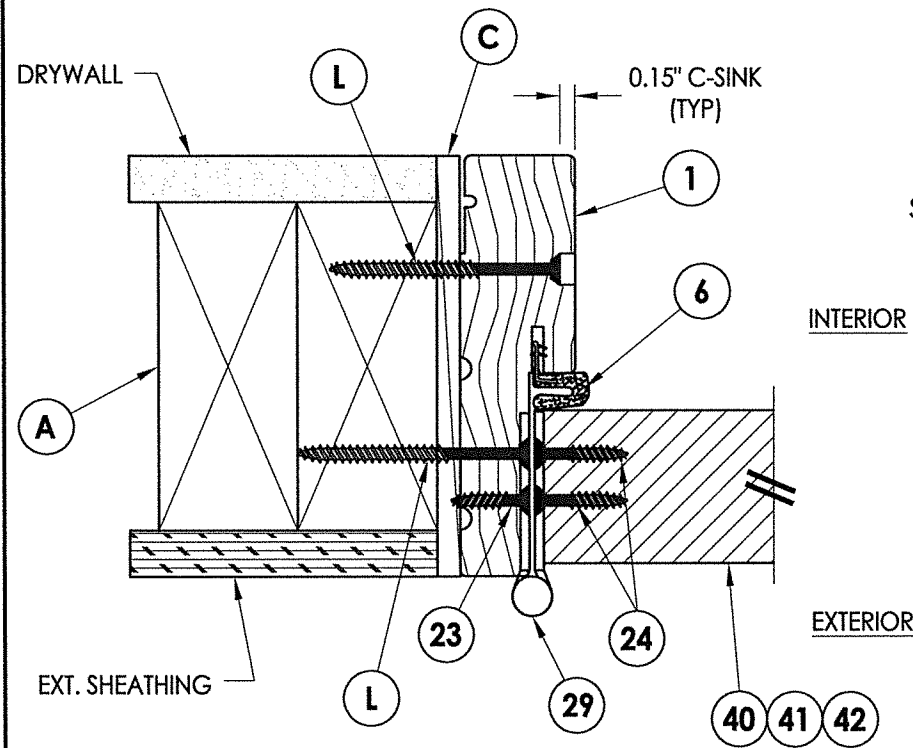

1 HORIZONTAL CROSS SECTION
5 Shown w/ 2X Buck
 Outswing shown (Inswing similar)

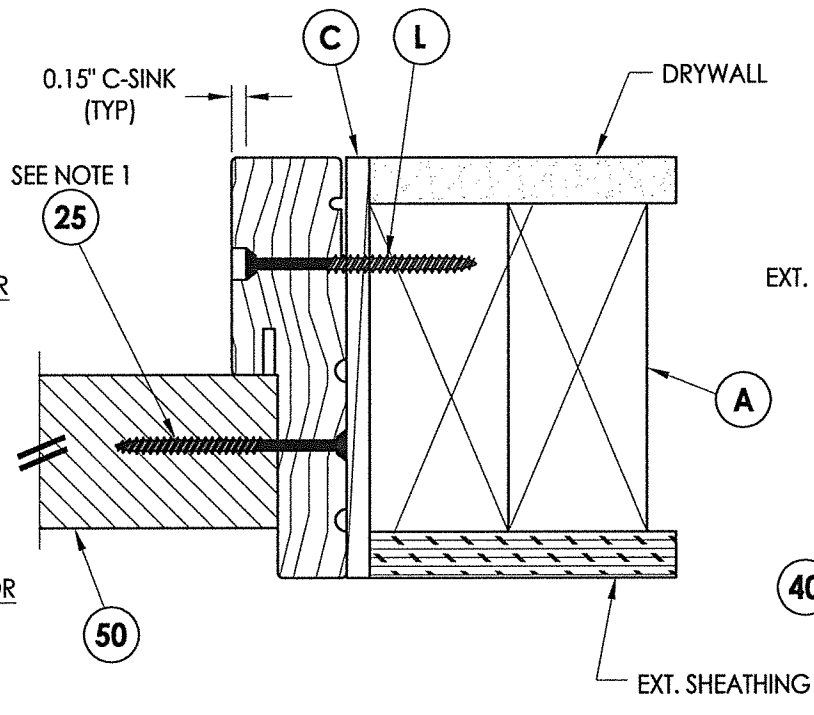

2 HORIZONTAL CROSS SECTION
5 Shown w/ 2X Buck
 Outswing shown (Inswing similar)

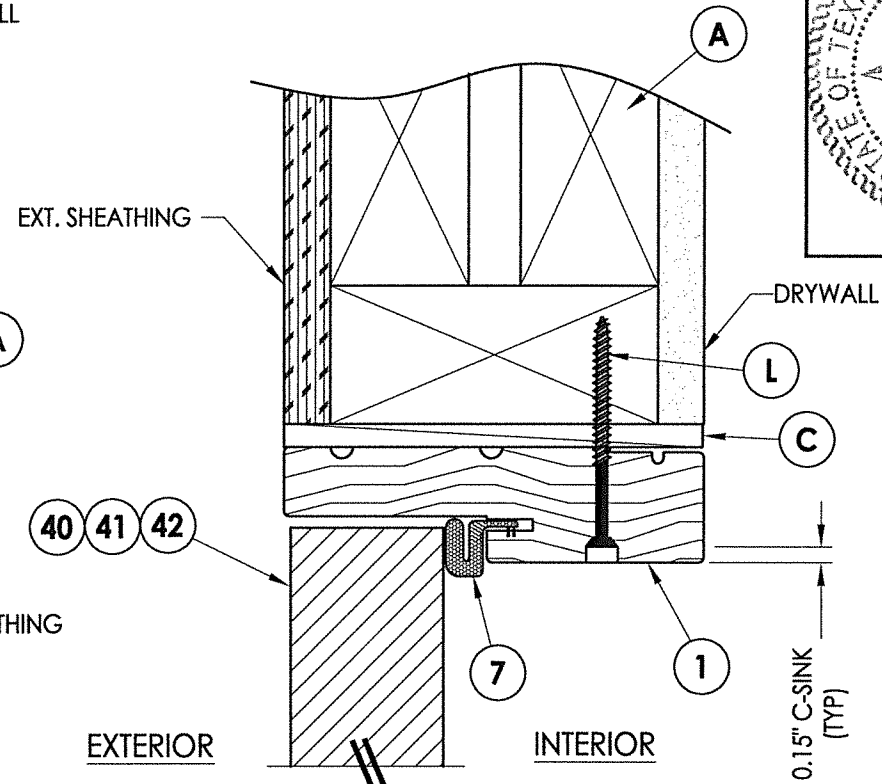

3 VERTICAL CROSS SECTION
5 Shown w/ 2X Buck
 Outswing shown (Inswing similar)

Notes:

- Sidelite assembly screws located 6" from each end and 5 more screws equally spaced between (7 screws total per side jamb).
- Sidelite assembly screws located 3" from each end & at centerline (3 screws along head jamb).

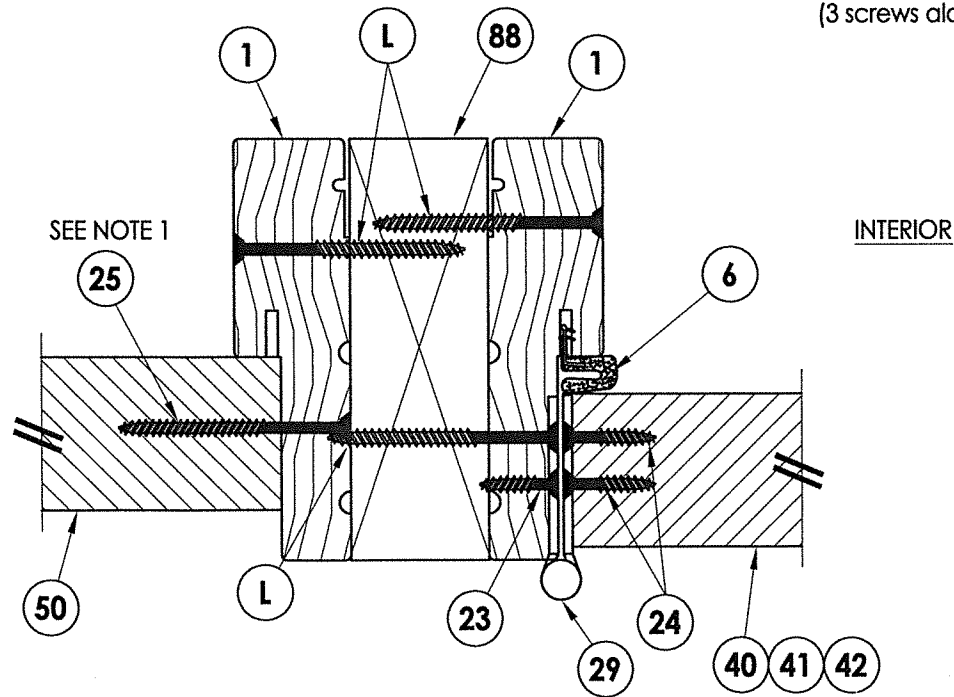

5 HORIZONTAL CROSS SECTION
5 Outswing shown (Inswing similar)

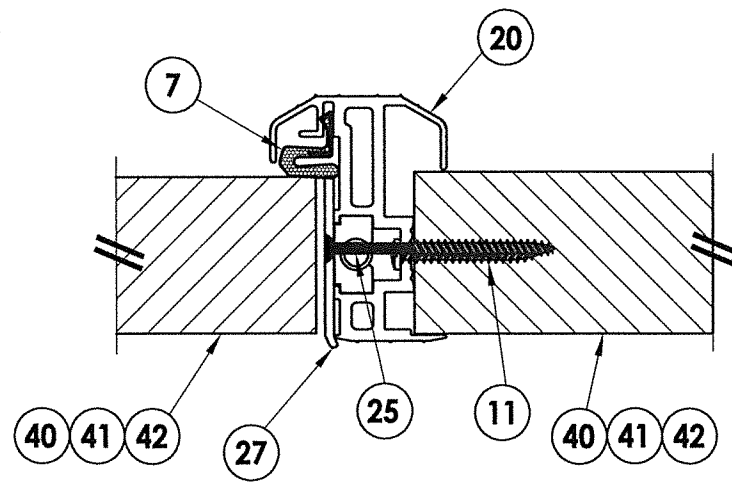

6 HORIZONTAL CROSS SECTION
5 Outswing shown (Inswing similar)

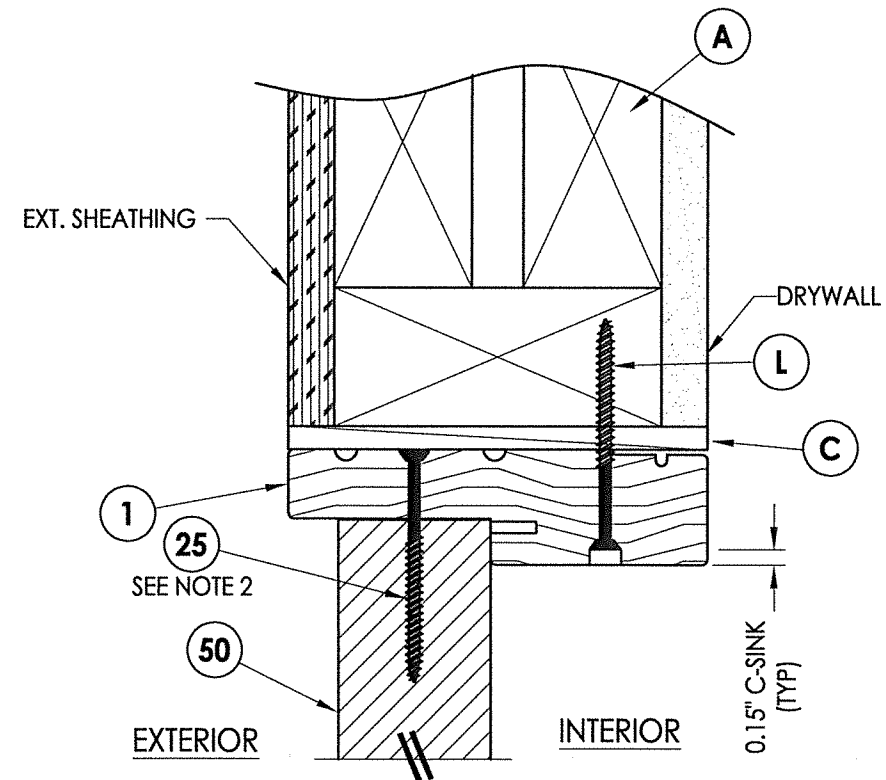

4 VERTICAL CROSS SECTION
5 Shown w/ 2X Buck
 Outswing shown (Inswing similar)

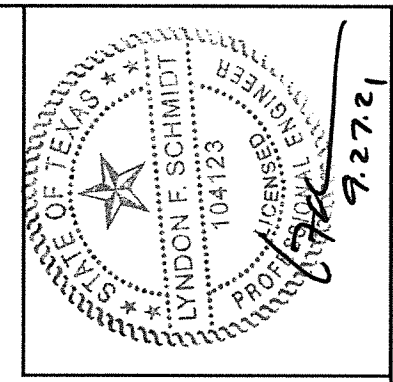

Documents Prepared By: Lyndon F. Schmidt, P.E.
 TEXAS P.E. #104123

RW BUILDING CONSULTANTS, INC.
 P.O. Box 230 Valrico FL 33595
 Phone No.: 813.659.9197

CERTIFICATE OF REGISTRATION # F-11852

PRODUCT:	THERMA-TRU FIBERGLASS DOOR
PART OR ASSEMBLY:	HORIZONTAL & VERTICAL CROSS SECTIONS

NO.	DATE	DESCRIPTION	LFS	BY
1	9/27/21	UPDATE TO 2018 IBC/IRC CODE		

DATE:	10/24/17
SCALE:	N.T.S.
DWG. BY:	JK
CHK. BY:	LFS
DRAWING NO.:	TX-4707
SHEET	5 OF 11

Z:\Clients\Therma Tru PERMANENT\B - Texas Dept of Ins\TDI - DR 951 - 68 & 8'0 Opaque Comp Edge Impact (TX 4705 - 4710)\C - Drawings\TX-4705-7.dwg

Notes:

- Sill Item #'s 16, 32, 33, 34, 35, 36, 37, 38 & 39 are attached to jambs w/ (3) #8 X 2-1/2" pfh screws at each end.
Sill Item #'s 17 & 18 are attached to jambs w/ (2) #8 X 2-1/2" pfh screws at each end.
Sill Item #15 is attached to jambs utilizing (2) #10 X 1-1/2" pph screws at each end.
- Sidelite assembly screws located 3" from each end & at centerline (3 screws along sill).

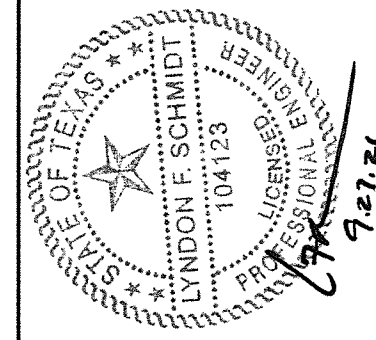

Documents Prepared By: Lyndon F. Schmidt, P.E.
TEXAS P.E. #104123

RW BUILDING CONSULTANTS, INC.
P.O. Box 230 Valrico FL 33595
Phone No.: 813.659.9197

CERTIFICATE OF REGISTRATION # F-11852

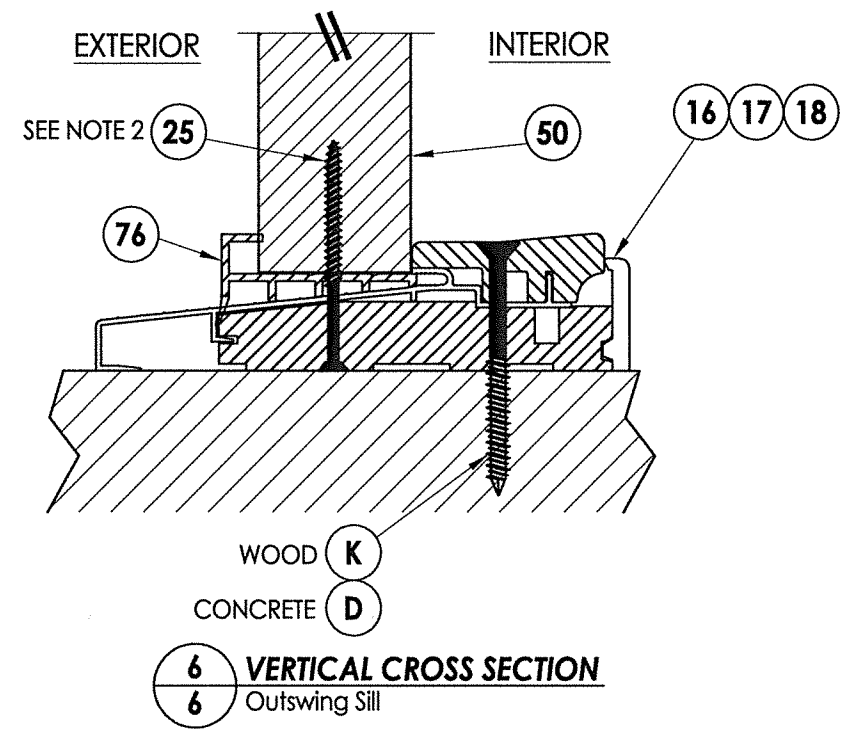
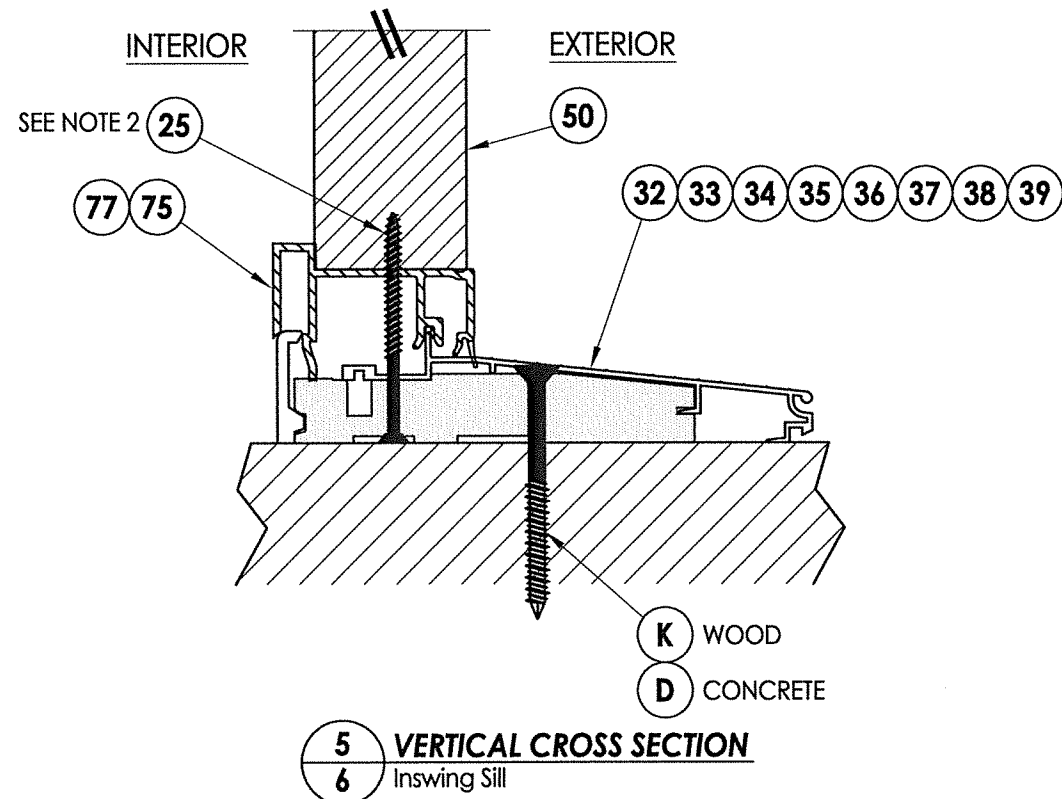
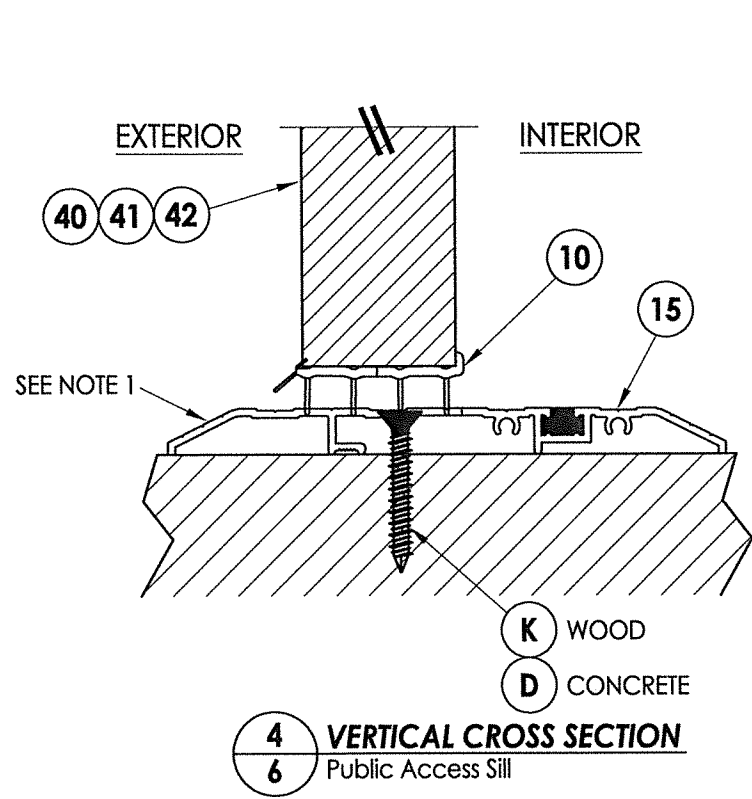
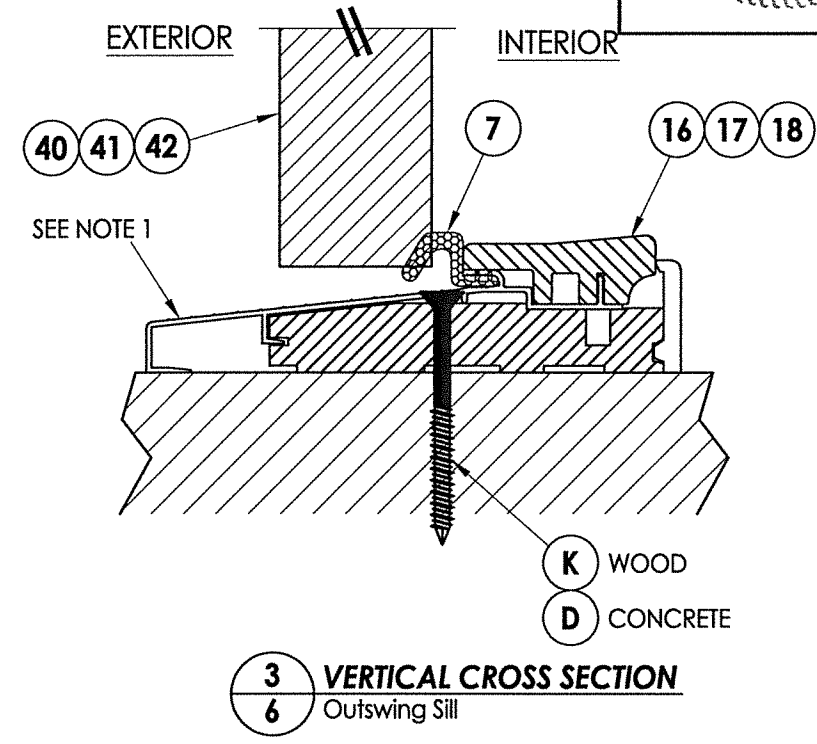
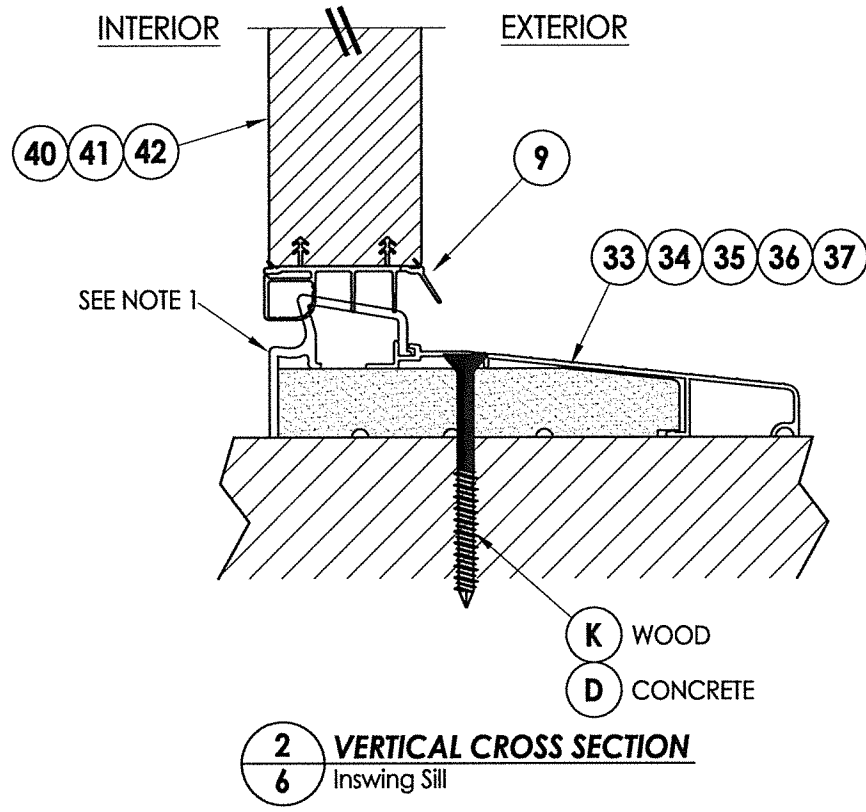
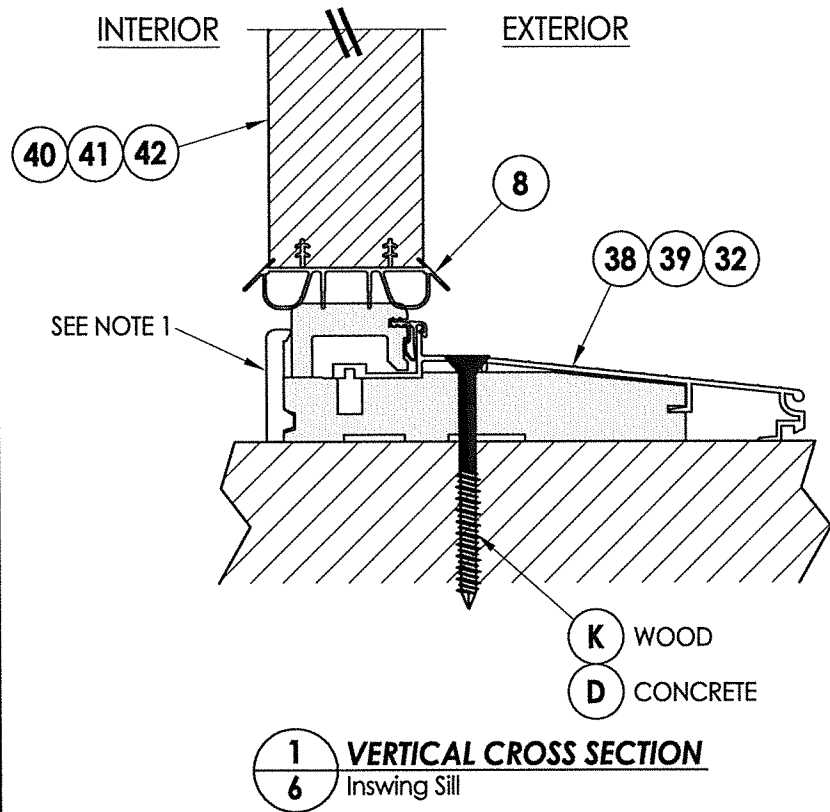

PRODUCT:		THERMA-TRU FIBERGLASS DOOR	
PART OR ASSEMBLY:		VERTICAL CROSS SECTIONS (THRESHOLDS)	
NO.	DATE	BY	LFS
1	9/27/21	DATE	DATE
REVISIONS			
DATE: 10/24/17			
SCALE: N.T.S.			
DWG. BY: JK			
CHK. BY: LFS			
DRAWING NO.: TX-4707			
SHEET 6 OF 11			

Z:\Clients\Therma Tru PERMANENT\B - Texas Dept of Ins\TDI - DR 951 - 68 & 80 Opaque Comp Edge Impact (TX 4705 - 4710)\C - Drawings\TX-4705-7.dwg

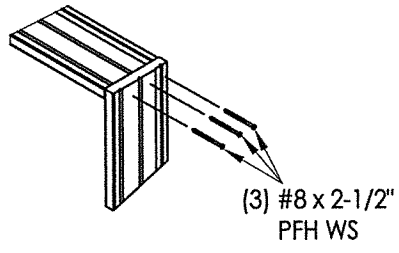

JAMB TO HEAD DETAIL
(TYP.)

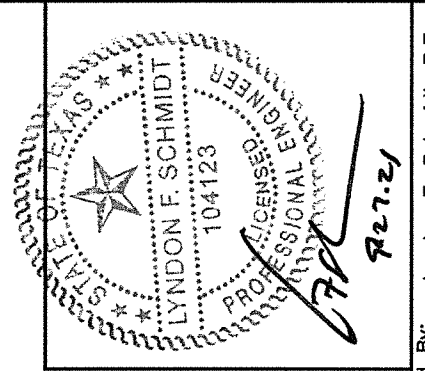

Documents Prepared By: Lyndon F. Schmidt, P.E.
TEXAS P.E. #104123

RW BUILDING CONSULTANTS, INC.
P.O. Box 230 Valrico FL 33595
Phone No.: 813.659.9197

CERTIFICATE OF REGISTRATION # F-11852

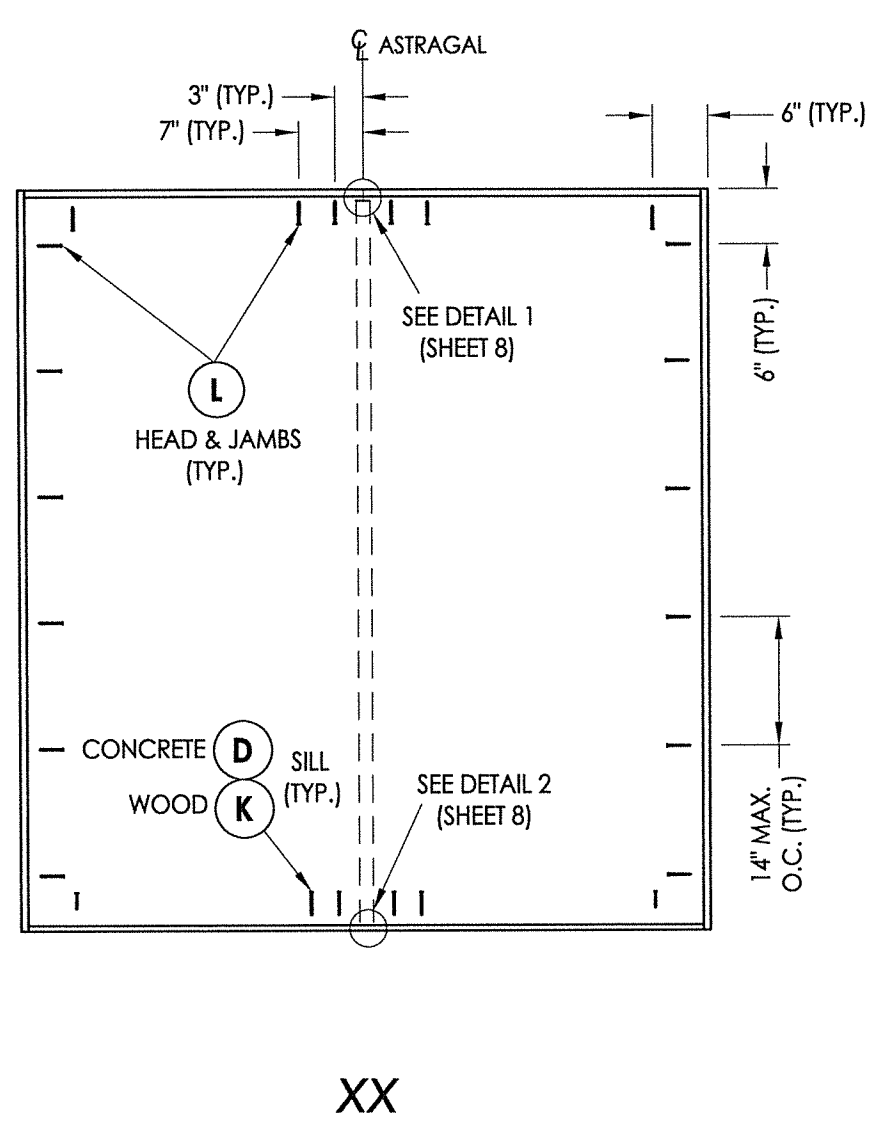

XX

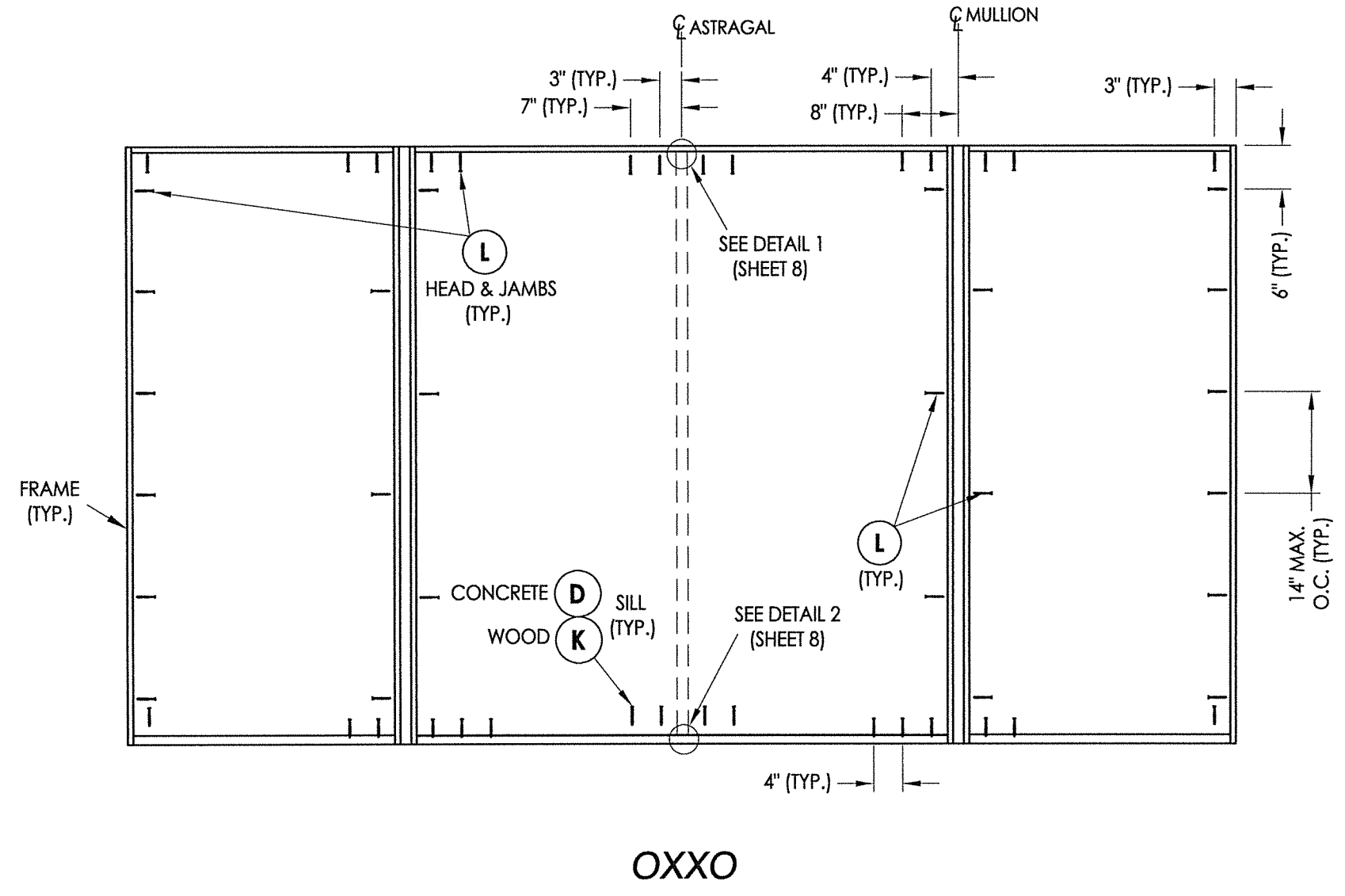

OXXO

FRAME ANCHORING

PRODUCT:		THERMA-TRU FIBERGLASS DOOR	
PART OR ASSEMBLY:		FRAME ANCHORING	
NO.	DATE	BY	REVISIONS
1	9/27/21	LFS	UPDATE TO 2018 IBC/IRC CODE

DATE: 10/24/17
SCALE: N.T.S.
DWG. BY: JK
CHK. BY: LFS
DRAWING NO.: TX-4707
SHEET 7 OF 11

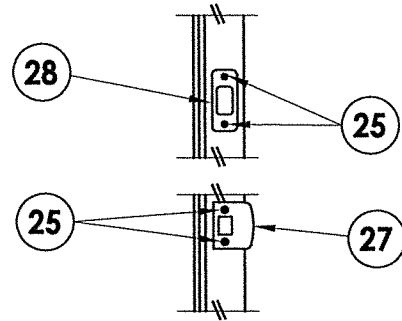

LATCH & DEADBOLT DETAIL
Schlage / Kwikset

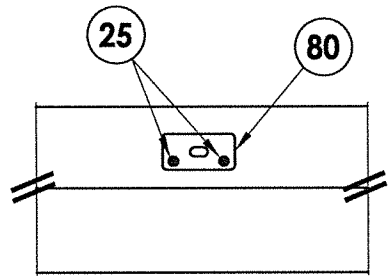

DETAIL 1
Coastal Astragal Strike Plate @ Head

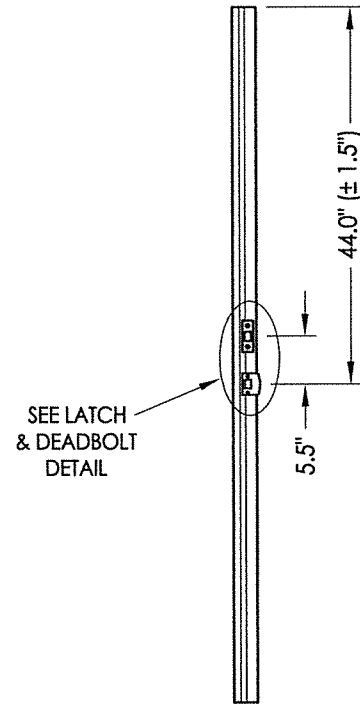

ASTRAGAL
Latch and Deadbolt

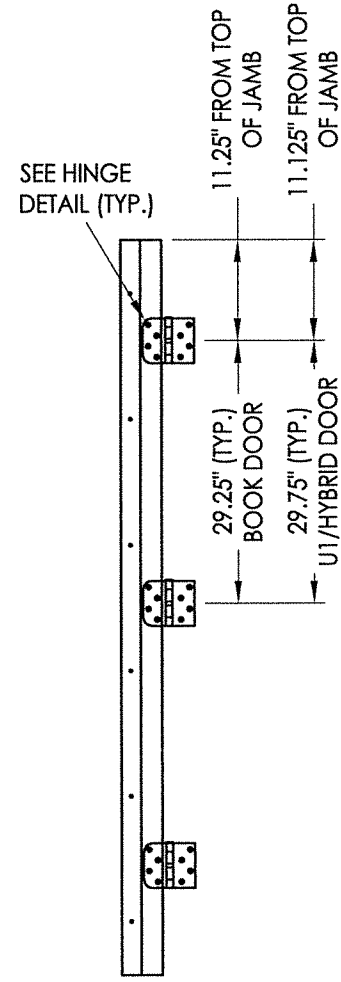

HINGE JAMB

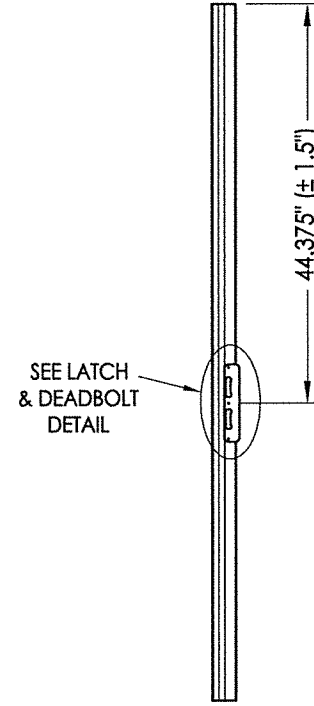

ASTRAGAL
Multipoint Lock

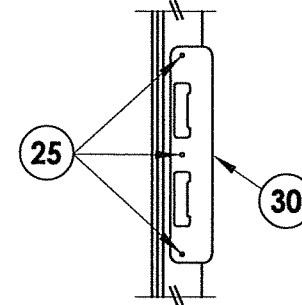

LATCH & DEADBOLT DETAIL
Multipoint Lock

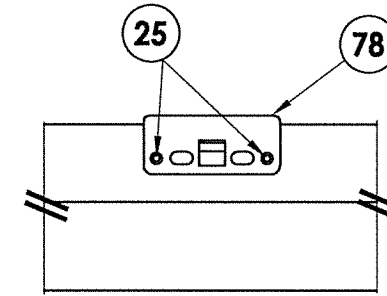

DETAIL 1
Multipoint Lock Strike Plate @ Head

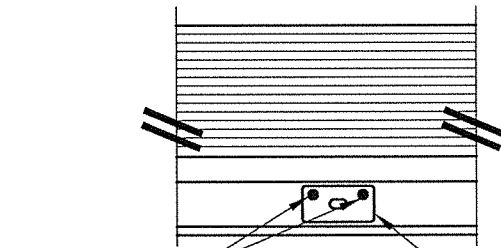

DETAIL 2
Inswing
Coastal Astragal Strike Plate @ Sill

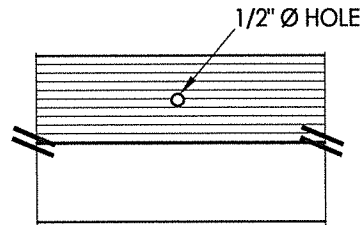

DETAIL 2
Outswing
Astragal Bolt Hole @ Sill

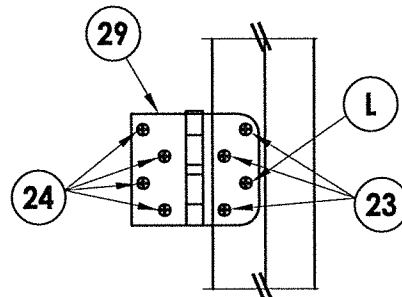

HINGE DETAIL

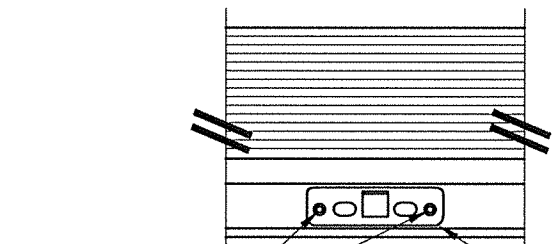

DETAIL 2
Inswing
Multipoint Lock Strike Plate @ Sill

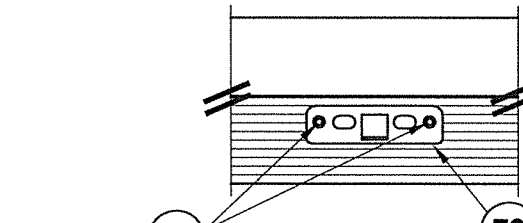

DETAIL 2
Outswing
Multipoint Lock Strike Plate @ Sill

MULTIPOINT LOCK STRIKE DETAILS

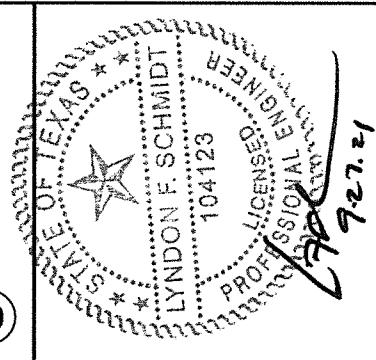

Documents Prepared By: Lyndon F. Schmidt, P.E.
TEXAS P.E. #104123

RW BUILDING CONSULTANTS, INC.
P.O. Box 230 Valrico FL 33595
Phone No.: 813.659.9197

CERTIFICATE OF REGISTRATION # F-11852

PRODUCT:	THERMA-TRU FIBERGLASS DOOR
PART OR ASSEMBLY:	HARDWARE DETAILS

NO.	DATE	DESCRIPTION	BY
1	9/27/21	UPDATE TO 2018 IBC/IRC CODE	LFS

DATE:	10/24/17
SCALE:	N.T.S.
DWG. BY:	JK
CHK. BY:	LFS
DRAWING NO.:	TX-4707
SHEET	8 OF 11

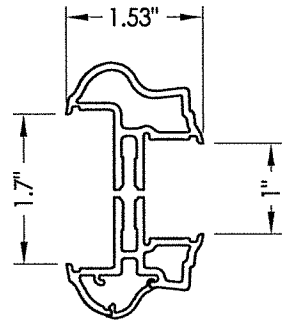

3A ALUMINUM FRAME
Aluminum Impact Lite Frame
Door Panels & Sidelites

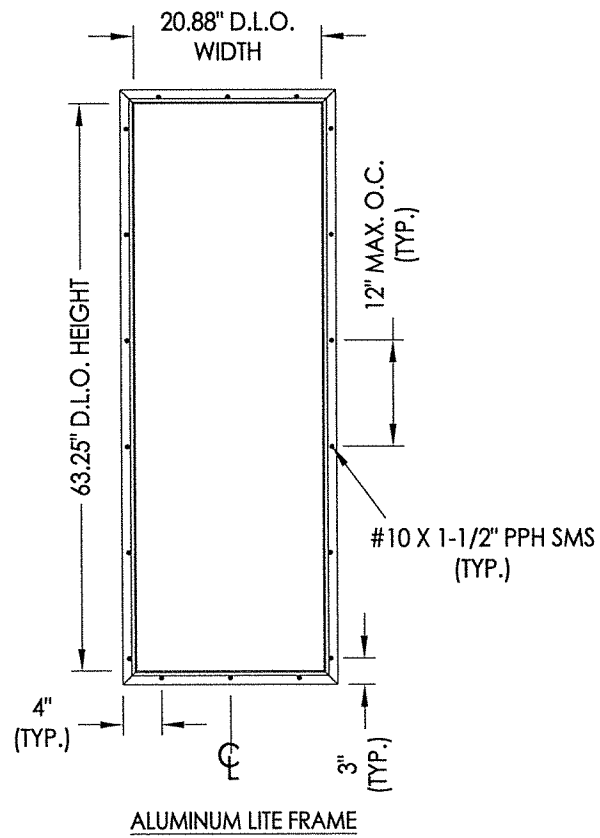

ALUMINUM LITE FRAME

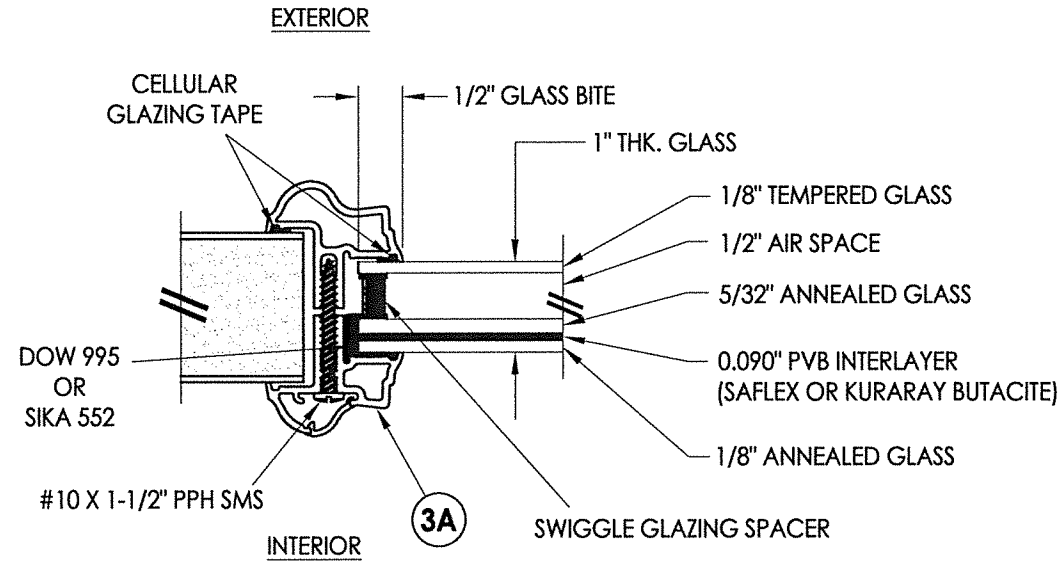

G1 GLAZING DETAIL
Aluminum Impact Lite Frame
Door Panels & Sidelites

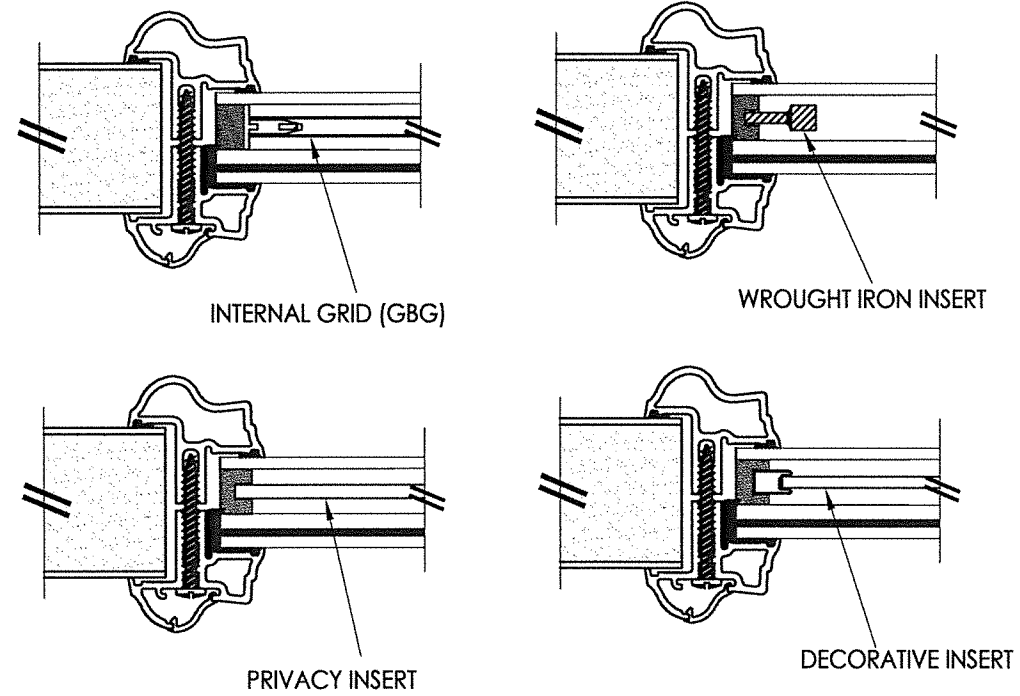

1" LAMINATED INSULATED IMPACT GLASS INSERT OPTIONS

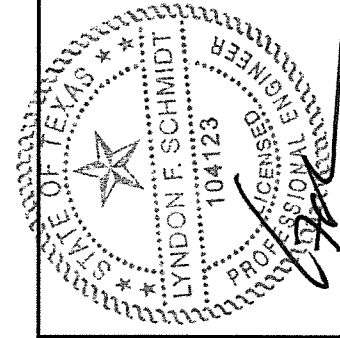

Documents Prepared By: Lyndon F. Schmidt, P.E.
TEXAS P.E. #104123

RW BUILDING CONSULTANTS, INC.
P.O. Box 230 Valrico FL 33595
Phone No.: 813.659.9197

CERTIFICATE OF REGISTRATION # F-11852

PRODUCT: THERMA-TRU
FIBERGLASS DOOR

PART OR ASSEMBLY:

GLAZING DETAILS

NO.	DATE	REVISIONS	BY
1	9/27/21	UPDATE TO 2018 IBC/IRC CODE	LFS

DATE: 10/24/17

SCALE: N.T.S.

DWG. BY: JK

CHK. BY: LFS

DRAWING NO.: TX-4707

SHEET 9 OF 11

Z:\Clients\Therma Tru PERMANENT\B - Texas Dept of Ins\TDI - DR 951 - 6'8 & 8'0 Opaque Comp Edge Impact (TX 4705 - 4710)\C - Drawings\TX-4705-7.dwg

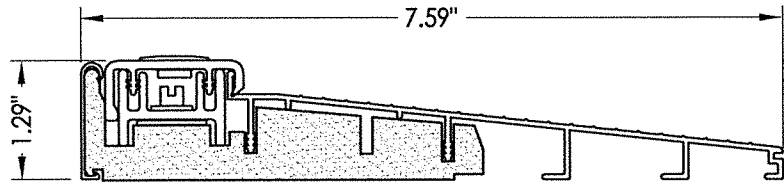

32 INSWING THRESHOLD
Inswing Basic Composite Adjustable Sill 7-1/2"

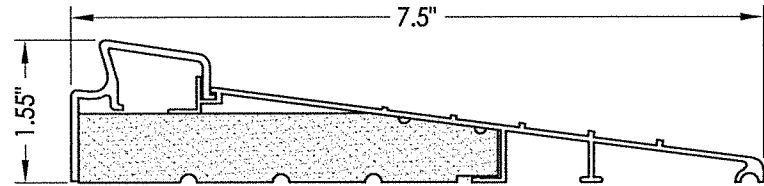

37 INSWING THRESHOLD
Inswing Basic Fixed 7-1/2" Sill

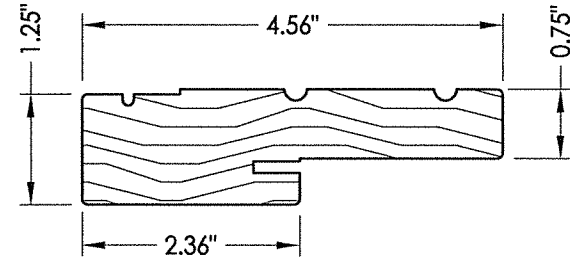

1 WOOD JAMB

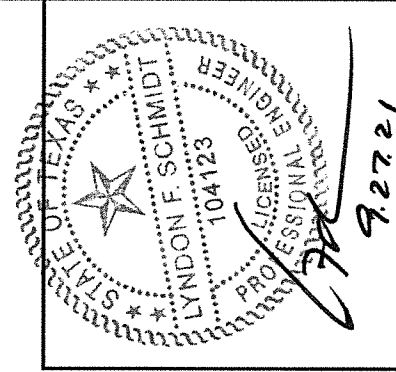

Documents Prepared By: Lyndon F. Schmidt, P.E.
TEXAS P.E. #104123

RW BUILDING CONSULTANTS, INC.
P.O. Box 230 Valrico FL 33595
Phone No.: 813.659.9197

CERTIFICATE OF REGISTRATION # F-11852

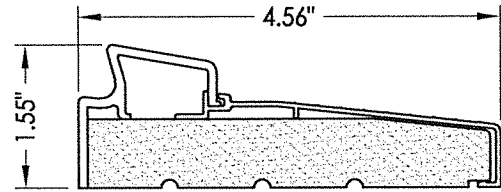

33 INSWING THRESHOLD
Inswing Basic Fixed Sill

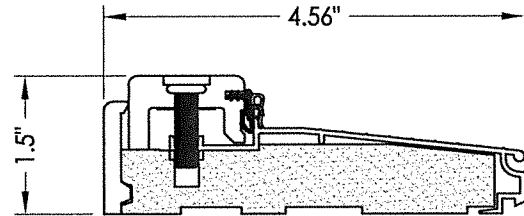

38 INSWING THRESHOLD
Inswing Composite Adjustable Sill

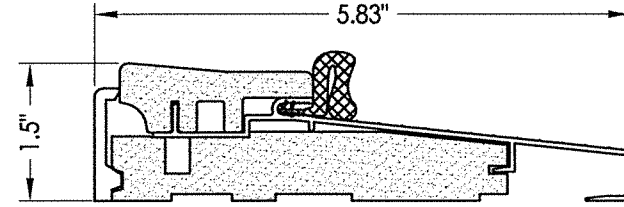

16 OUTSWING THRESHOLD
Composite Sill

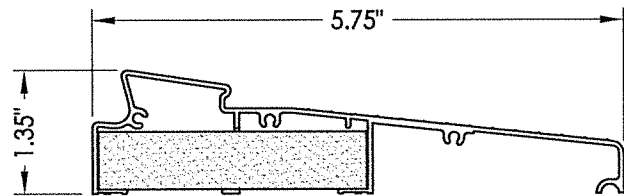

34 INSWING THRESHOLD
Inswing Moderate Climate Sill 1-3/8"

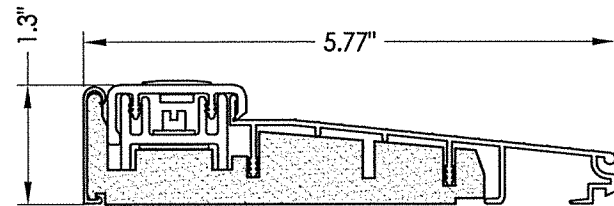

39 INSWING THRESHOLD
Inswing Basic Composite Adjustable Sill

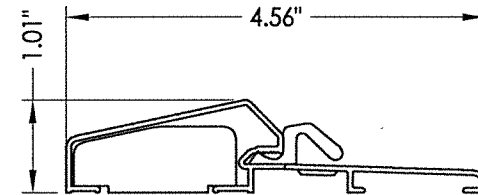

17 OUTSWING THRESHOLD
Composite / Aluminum Sill

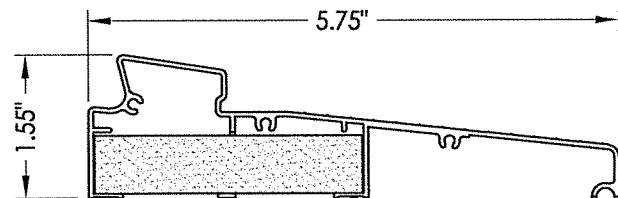

35 INSWING THRESHOLD
Inswing Moderate Climate Sill

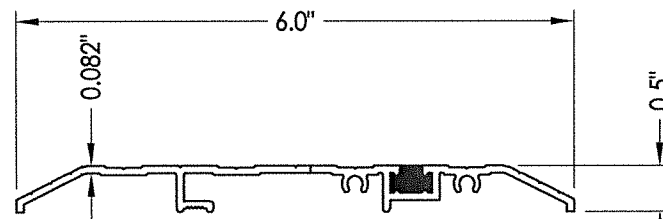

15 PUBLIC ACCESS THRESHOLD

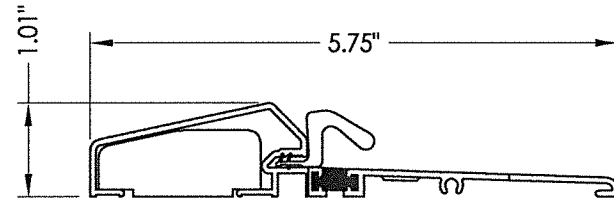

18 OUTSWING THRESHOLD
Composite / Aluminum Sill
(Thermal Break)

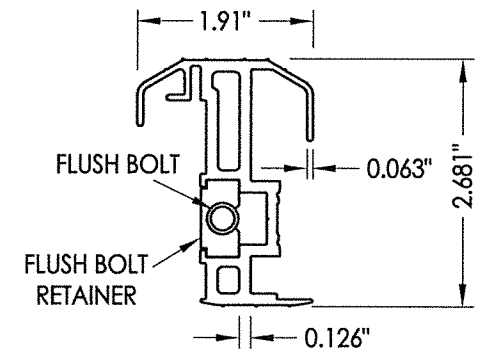

20 COASTAL ALUMINUM ASTRAGAL

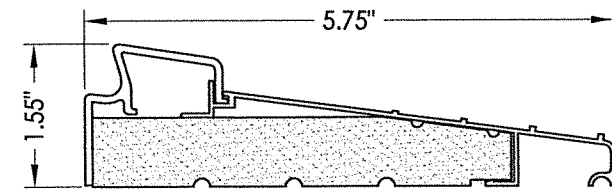

36 INSWING THRESHOLD
Inswing Basic Fixed 5-3/4" Sill

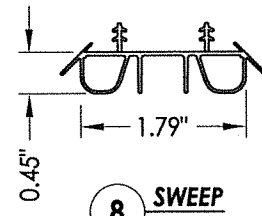

8 SWEEP

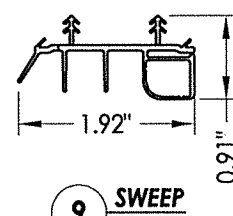

9 SWEEP

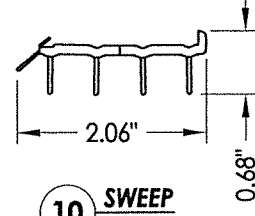

10 SWEEP

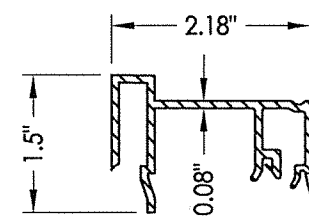

75 SIDELITE SPACER
Inswing

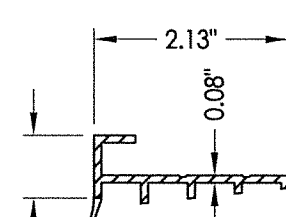

76 SIDELITE SPACER
Outswing

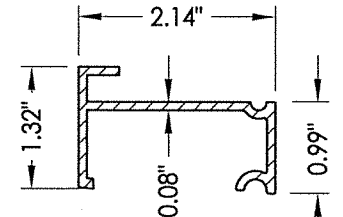

77 SIDELITE SPACER
Inswing
Moderate Climate Threshold

PRODUCT:		THERMA-TRU FIBERGLASS DOOR	
PART OR ASSEMBLY:		COMPONENTS	
NO.	DATE	UPDATE TO 2018 IBC/IRC CODE	BY
1	9/27/21		LFS
DATE: 10/24/17		SCALE: N.T.S.	
DWG. BY: JK		CHK. BY: LFS	
DRAWING NO.: TX-4707		SHEET 10 OF 11	

BILL OF MATERIALS

ITEM #	DESCRIPTION	MATERIAL
A	2X FRAMING (SG >= 0.42)	WOOD
C	1/4" MAX. SHIM SPACE	-
D	1/4" PFH DeWALT OR ITW CONCRETE SCREW (1-3/4" MIN. EMBEDMENT)	STEEL
G	3/16" PFH DeWALT OR ITW CONCRETE SCREW (1-3/4" MIN. EMBEDMENT)	STEEL
K	#12 PFH WOOD SCREW (1-1/2" MIN. EMBEDMENT)	STEEL
L	#10 X 2-1/2" PFH WOOD SCREW (1.15" MIN. EMBEDMENT)	STEEL
1	JAMB (FINGER JOINT PINE)	WOOD
6	WEATHERSTRIP (MEDIUM REACH)	FOAM
7	WEATHERSTRIP (LONG REACH)	FOAM
8	SWEEP	VINYL
9	SWEEP (USE w/ MODERATE CLIMATE THRESHOLD)	VINYL
10	SWEEP (USE w/ PUBLIC ACCESS THRESHOLD)	VINYL
11	#10 X 1-1/2" PPH SMS	STEEL
15	PUBLIC ACCESS THRESHOLD	ALUM
16	OUTSWING THRESHOLD	ALUM/COMP
17	OUTSWING THRESHOLD	ALUM/COMP
18	OUTSWING THRESHOLD	ALUM/COMP
20	COASTAL ALUMINUM ASTRAGAL	ALUM
23	#10 x 3/4" PFH WOOD SCREW	STEEL
24	#10 x 1" PFH WOOD SCREW	STEEL
25	#8 x 2-1/2" PFH WOOD SCREW	STEEL
26	#8 x 5/8" PFH WOOD SCREW	STEEL
27	LATCH STRIKE PLATE	STEEL
28	DEADBOLT SUB STRIKE PLATE	STEEL
29	4" X 4" HINGE	STEEL
30	LATCH & DEADBOLT STRIKE PLATE (TONGUE SYSTEM)	ALUM/COMP
31	MULTIPOINT STRIKE PLATE (TONGUE SYSTEM)	ALUM/COMP
32	INSWING THRESHOLD	ALUM/COMP
33	INSWING THRESHOLD	ALUM/COMP
34	INSWING THRESHOLD	ALUM/COMP
35	INSWING THRESHOLD	ALUM/COMP
36	INSWING THRESHOLD	ALUM/COMP
37	INSWING THRESHOLD	ALUM/COMP
38	INSWING THRESHOLD	ALUM/COMP
39	INSWING THRESHOLD	ALUM/COMP
40	DOOR PANEL (BOOK)	-
41	DOOR PANEL (HYBRID)	-
42	DOOR PANEL (U1)	-
50	SIDELITE	-
75	SIDELITE SPACER (INSWING)	PVC
76	SIDELITE SPACER (OUTSWING)	PVC
77	SIDELITE SPACER (INSWING) - MODERATE CLIMATE SILL	PVC
78	MULTIPOINT LOCK STRIKE PLATE @ HEAD	STEEL
79	MULTIPOINT LOCK STRIKE PLATE @ SILL	STEEL
80	ASTRAGAL STRIKE PLATE	STEEL
88	2X MULLION (SG >= 0.55)	WOOD

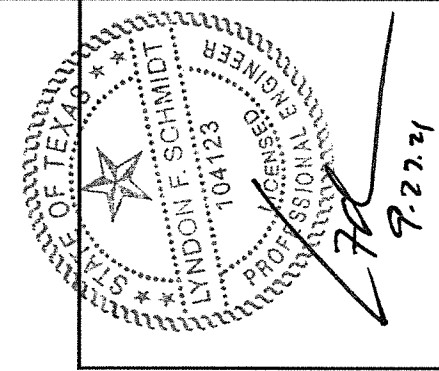

Documents Prepared By: Lyndon F. Schmidt, P.E.
TEXAS P.E. #104123

RW BUILDING CONSULTANTS, INC.
P.O. Box 230 Valrico FL 33595
Phone No.: 813.659.9197

CERTIFICATE OF REGISTRATION # F-11652

PRODUCT: THERMA-TRU FIBERGLASS DOOR
PART OR ASSEMBLY: BILL OF MATERIALS

NO.	DATE	DESCRIPTION	BY
1	9/27/21	UPDATE TO 2018 IBC/IRC CODE	LFS

DATE: 10/24/17
SCALE: N.T.S.
DWG. BY: JK
CHK. BY: LFS
DRAWING NO.: TX-4707
SHEET 11 OF 11

CONCRETE ANCHOR NOTES:

- Concrete anchor locations at the corners may be adjusted to maintain the min. edge distance to mortar joints.
- Concrete anchor locations noted as "MAX. ON CENTER" must be adjusted to maintain the min. edge distance to mortar joints, additional concrete anchors may be required to ensure the "MAX. ON CENTER" dimension are not exceeded.
- Concrete anchor table:

ANCHOR TYPE	ANCHOR SIZE	MIN. EMBEDMENT	MIN. CLEARANCE TO MASONRY EDGE	MIN. CLEARANCE TO ADJACENT ANCHOR
ITW TAPCON®	1/4"	1-3/4"	2"	4"
DeWALT ULTRACON®	1/4"	1-3/4"	1"	4"
ITW TAPCON®	3/16"	1-3/4"	3"	1-1/2"

WOOD SCREW INSTALLATION NOTES:

- Maintain a minimum 5/8" edge distance, 1" end distance, & 1" o.c. spacing of wood screws to prevent the splitting of wood.