

Glazed Steel Door

"NON-IMPACT" INSWING / OUTSWING

EVALUATED FOR USE IN THE STATE OF TEXAS

The Glazed Steel Door system described herein complies with the 2018 International Residential Code (IRC), Sections R301 & R609 and the 2018 International Building Code (IBC), Sections 1404.13, 1609, 1709.5, 2403 and 2404 subject to the following conditions:

1. Anchors shall be as listed and spaced as shown in the details. Anchor embedment to base material shall be beyond wall dressing or stucco.
2. When used in areas requiring wind-borne debris protection this product is required to be protected with an impact resistant covering that complies with Section R301.2.1.2 of the IRC and Section 1609.2 of the IBC.
3. Allowable design pressure requirements must be equal to or less than the design pressure rating shown in the design pressure chart, sheet 1 of this drawing.
4. Conditions not covered by this drawing are subject to further engineering analysis.

TABLE OF CONTENTS

| SHEET# | DESCRIPTION |
|--------|--|
| 1 | Typical elevations, design pressures & general notes |
| 2 | Door panel details |
| 3 | Horizontal & vertical cross sections |
| 4 | Vertical cross sections |
| 5 | Frame anchoring |

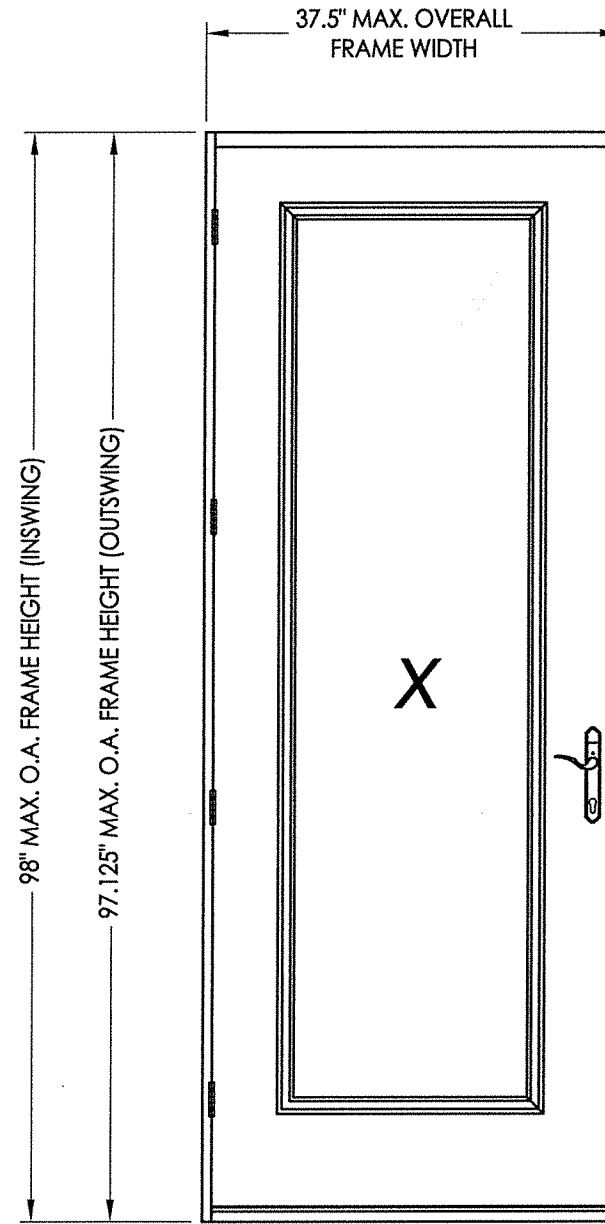

| CONFIG. | MODEL | DESIGN PRESSURE (PSF) | |
|---------|----------|-----------------------|----------|
| | | POSITIVE | NEGATIVE |
| X | INSWING | +35.0 | -35.0 |
| X | OUTSWING | +45.0 | -45.0 |

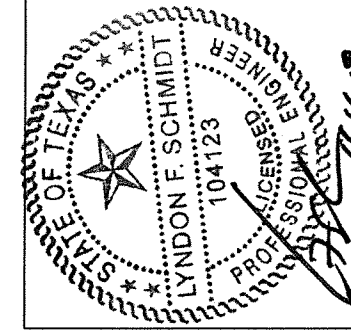

Documents Prepared By: Lyndon F. Schmidt, P.E.
TEXAS P.E. #104123

RW BUILDING CONSULTANTS, INC.
P.O. Box 230 Valrico FL 33595
Phone No.: 813.659.9197

TEXAS BOARD OF PROFESSIONAL ENGINEERS
CERTIFICATE OF REGISTRATION # F-11852

| | | |
|--|---|-----|
| PRODUCT: | ENDURA | |
| PART OR ASSEMBLY: | TYPICAL ELEVATION, DESIGN PRESSURES & GENERAL NOTES | |
| NO. | DATE | BY |
| 1 | 10/23/19 | LFS |
| ADD "FusionFrame" OPTION & UPDATE TO 2018 IBC/IRC CODE | | |
| REVISIONS | | |
| DATE: | 11/16/16 | |
| SCALE: | N.T.S. | |
| DWG. BY: | JK | |
| CHK. BY: | LFS | |
| DRAWING NO.: | TX-4686 | |
| SHEET | 1 OF 5 | |

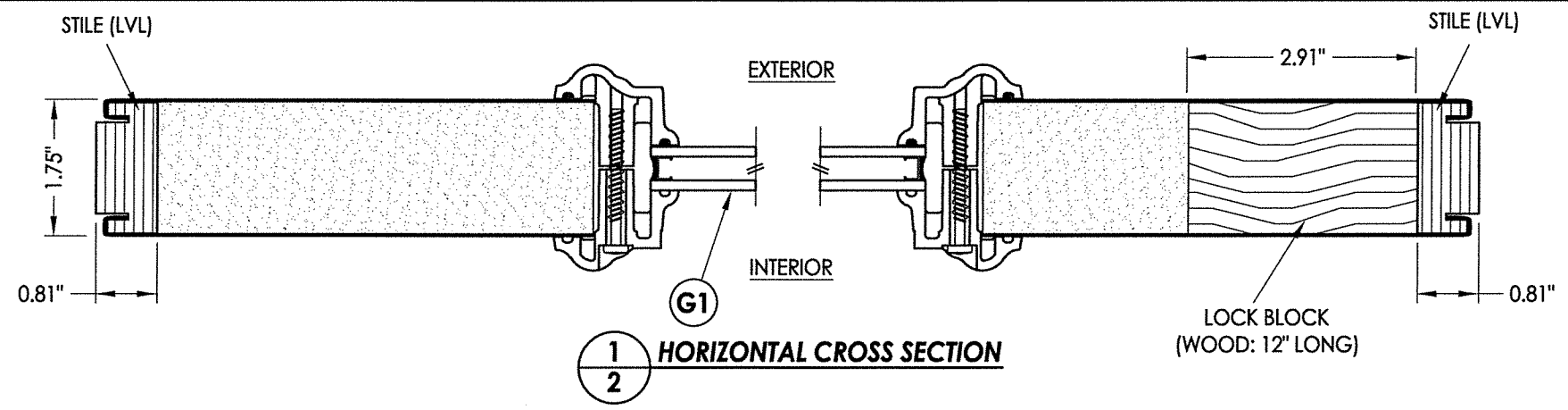

1
2 **HORIZONTAL CROSS SECTION**

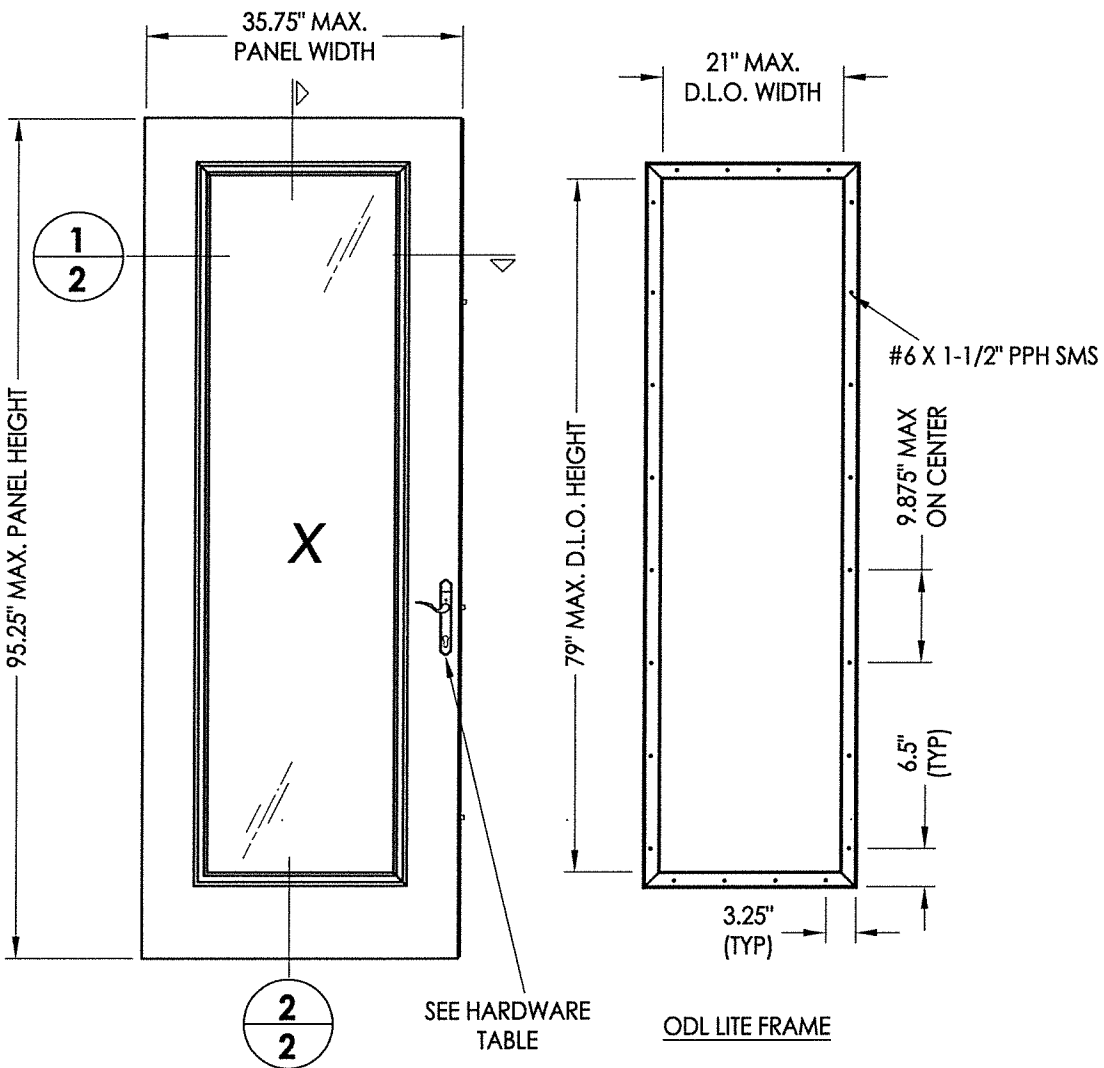

2
2 **DOOR PANEL**
Masonite
Steel (Wood Edge)

ODL LITE FRAME

| HARDWARE TABLE | |
|----------------|---|
| MANUFACTURER | MODEL |
| Endura | Trilennium® 3000 Series Multipoint lock (3pt.) |

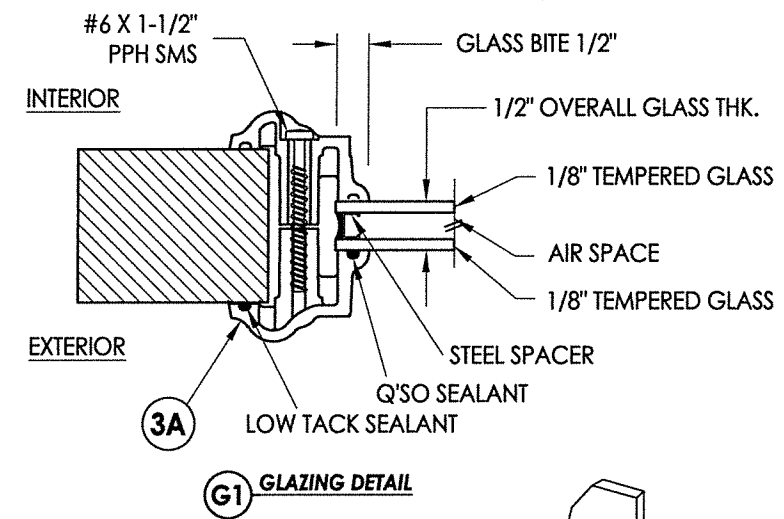

G1 **GLAZING DETAIL**

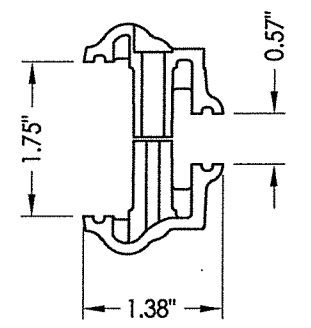

3A **ODL LITE FRAME**
HP Polypropylene

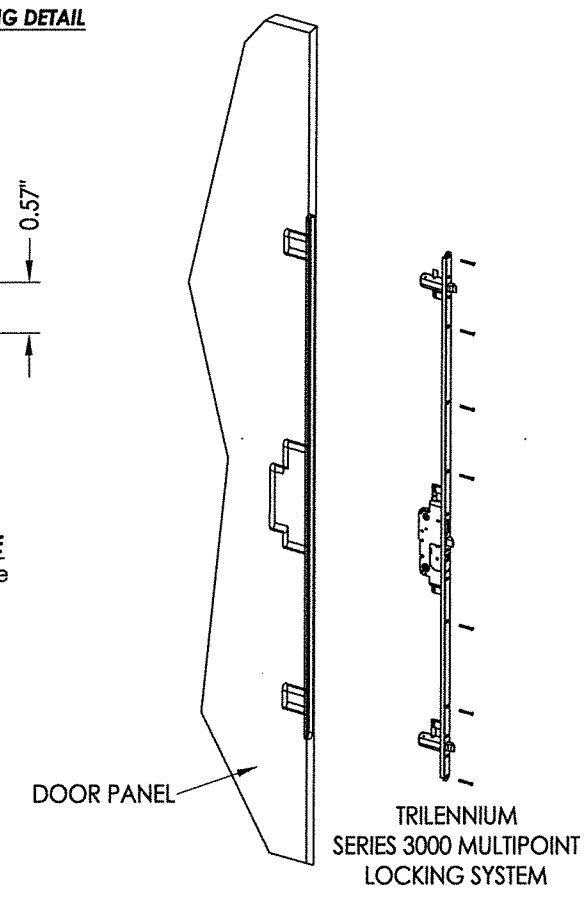

TRILENNIUM
SERIES 3000 MULTIPPOINT
LOCKING SYSTEM

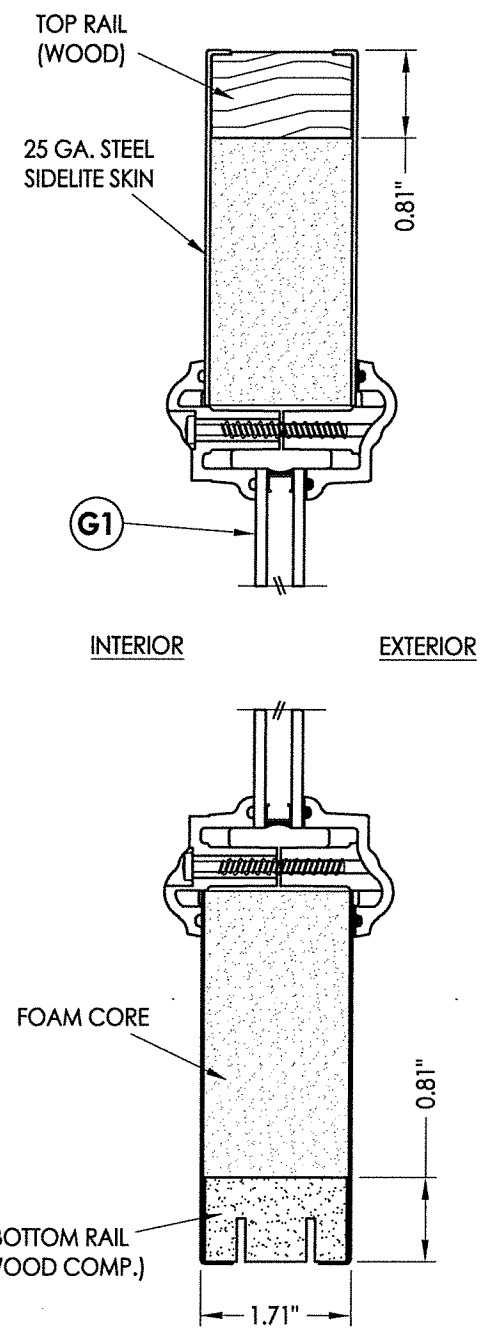

2
2 **VERTICAL CROSS SECTION**

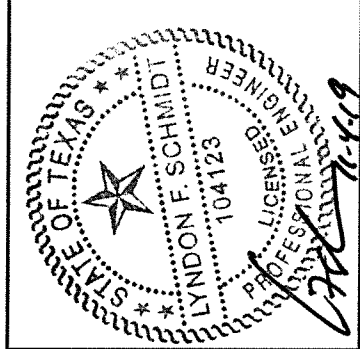

Documents Prepared By: Lyndon F. Schmidt, P.E.
TEXAS P.E. #104123

RW BUILDING CONSULTANTS, INC.
P.O. Box 230 Valrico FL 33595
Phone No.: 813.659.9197

TEXAS BOARD OF PROFESSIONAL ENGINEERS
CERTIFICATE OF REGISTRATION # F-11852

| | |
|-------------------|--------------------|
| PRODUCT: | ENDURA |
| PART OR ASSEMBLY: | DOOR PANEL DETAILS |
| DATE: | 11/16/16 |
| SCALE: | N.T.S. |
| DWG. BY: | JK |
| CHK. BY: | LFS |
| DRAWING NO.: | TX-4686 |
| SHEET | 2 OF 5 |

| NO. | DATE | BY | REVISIONS |
|-----|----------|-----|--|
| 1 | 10/23/19 | LFS | ADD "FusionFrame" OPTION & UPDATE TO 2018 IBC/IRC CODE |

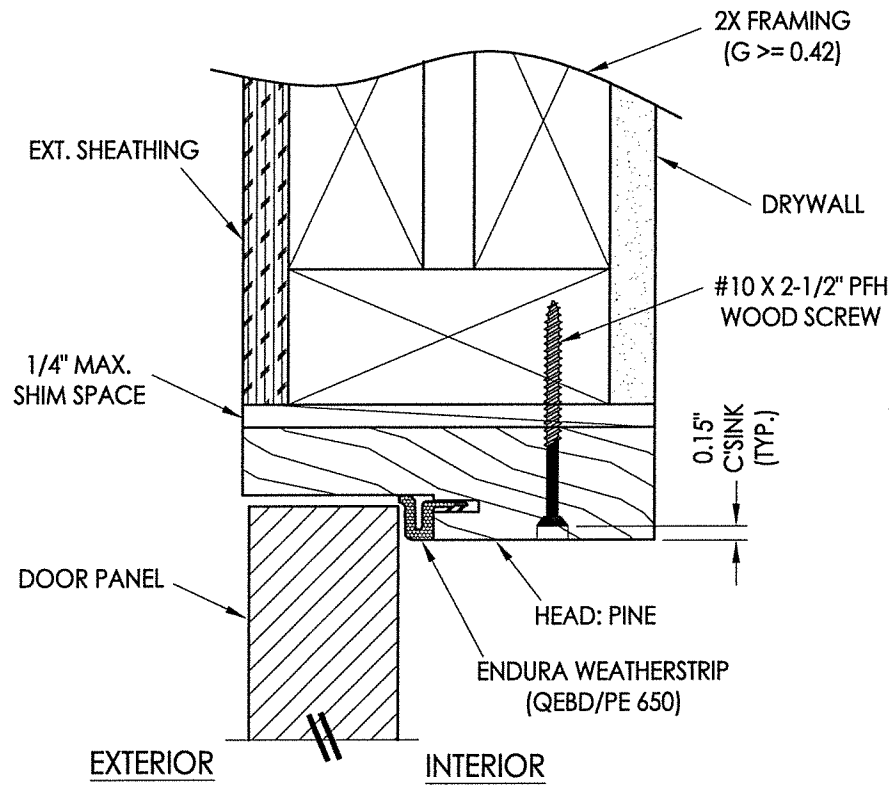
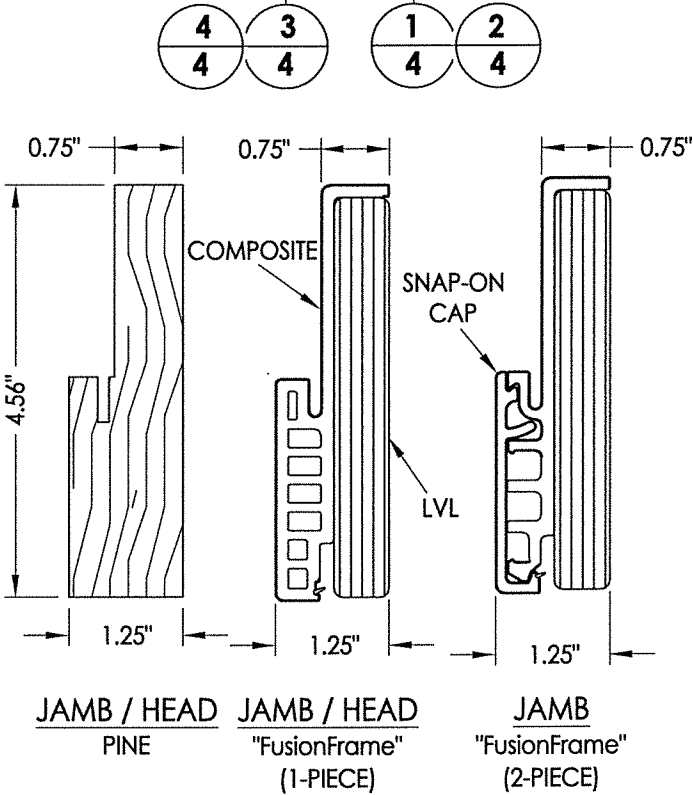
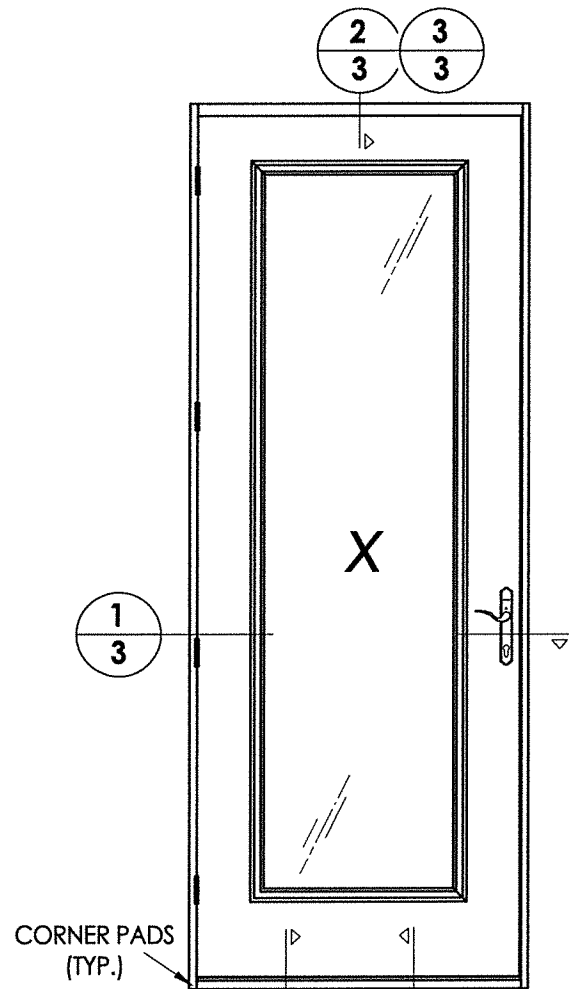

2 VERTICAL CROSS SECTION
3 Outswing shown - inswing also approved

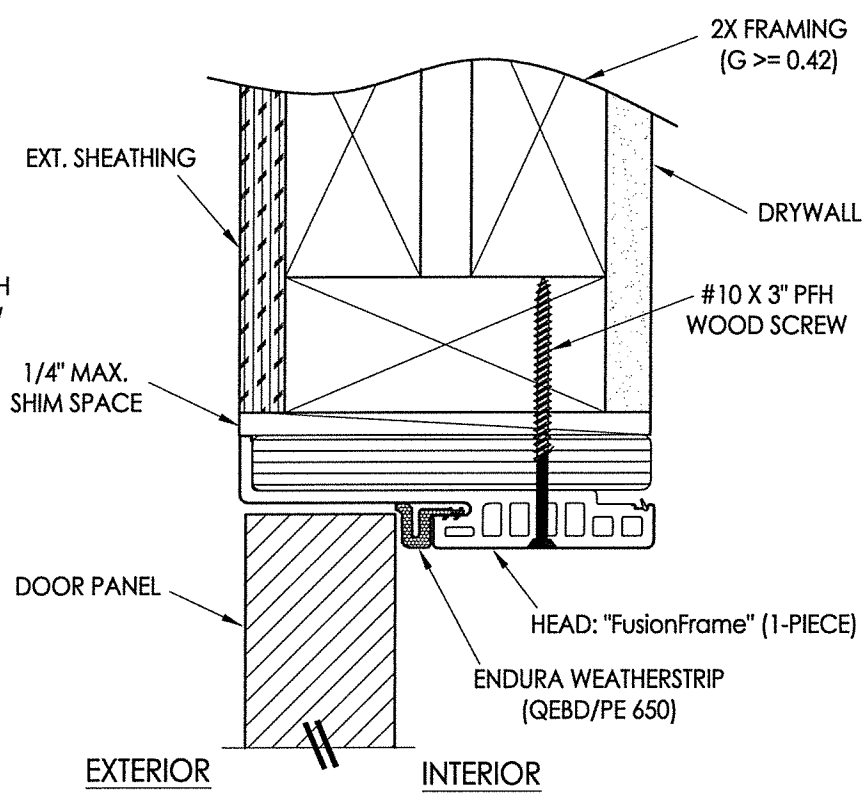

3 VERTICAL CROSS SECTION
3 Outswing shown - inswing also approved

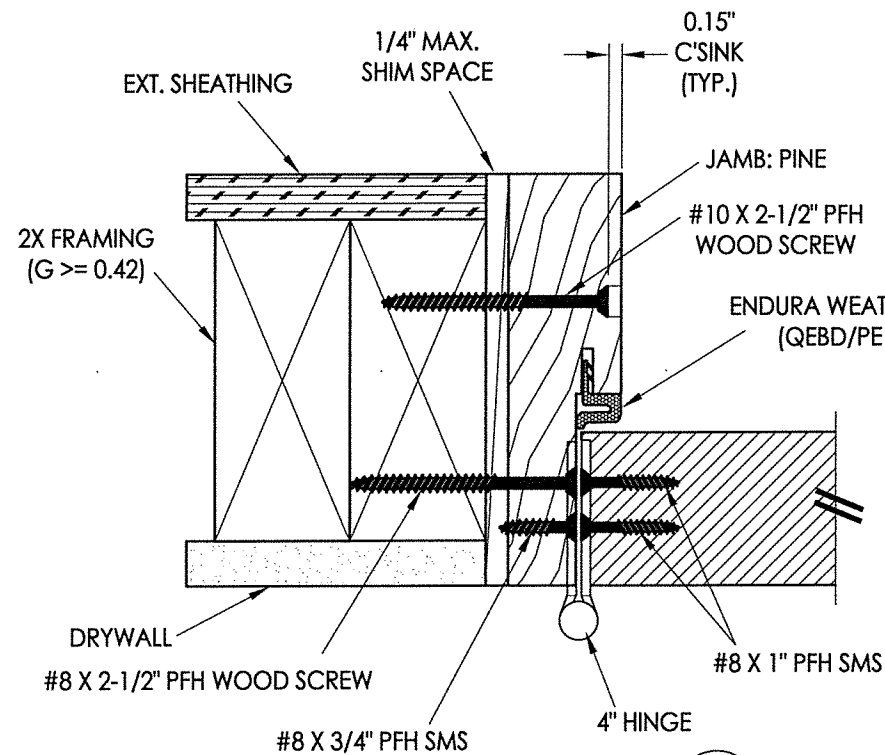

1 HORIZONTAL CROSS SECTION
3 Inswing shown - Outswing also approved

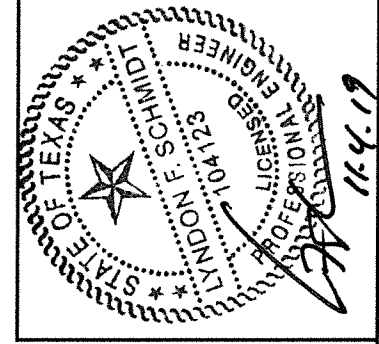
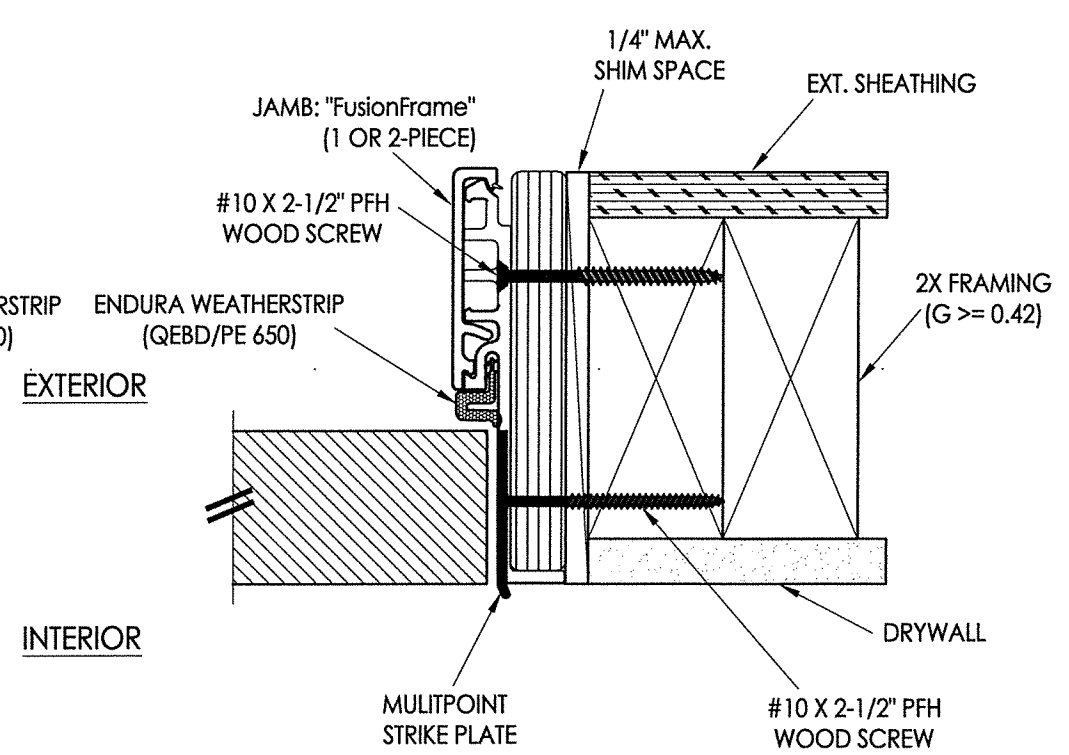

Documents Prepared By: Lyndon F. Schmidt, P.E.
 TEXAS P.E. #104123

RW BUILDING CONSULTANTS, INC.
 P.O. Box 230 Valrico FL 33595
 Phone No.: 813.659.9197

TEXAS BOARD OF PROFESSIONAL ENGINEERS
 CERTIFICATE OF REGISTRATION # F-11852

| | |
|-------------------|--------------------------------------|
| PRODUCT: | ENDURA |
| PART OR ASSEMBLY: | HORIZONTAL & VERTICAL CROSS SECTIONS |

| NO. | DATE | BY | REVISIONS |
|-----|----------|-----|--|
| 1 | 10/23/19 | LFS | ADD "FusionFrame" OPTION & UPDATE TO 2018 IBC/IRC CODE |

| | |
|--------------|----------|
| DATE: | 11/16/16 |
| SCALE: | N.T.S. |
| DWG. BY: | JK |
| CHK. BY: | LFS |
| DRAWING NO.: | TX-4686 |
| SHEET | 3 of 5 |

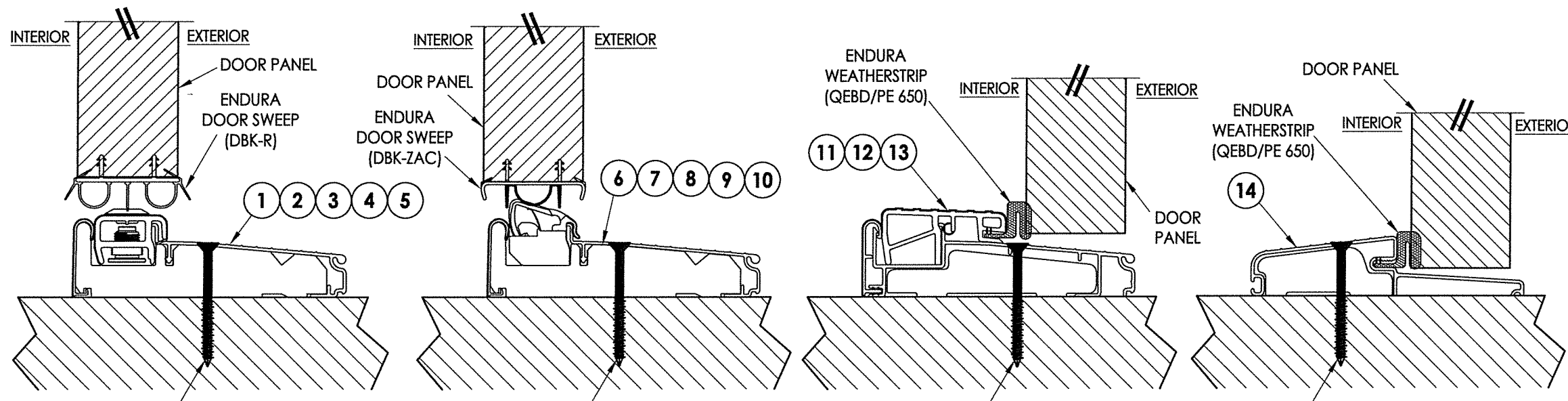

#10 X 2.5" PFH WOOD SCREW OR 1/4" X 2-3/4" ELCO OR ITW CONCRETE SCREW

1 VERTICAL CROSS SECTION
4 Inswing Adjustable Threshold

2 VERTICAL CROSS SECTION
4 Inswing Articulating Threshold

3 VERTICAL CROSS SECTION
4 Outswing Bump Threshold

4 VERTICAL CROSS SECTION
4 Outswing Bump Threshold

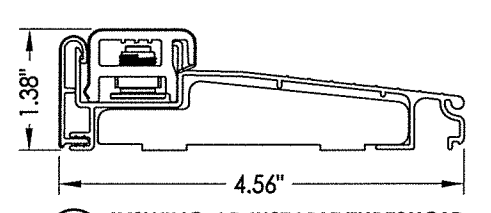

1 INSWING ADJUSTABLE THRESHOLD
ZAIL4565

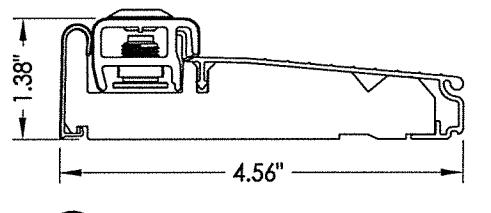

2 INSWING ADJUSTABLE THRESHOLD
ZAI4565FN

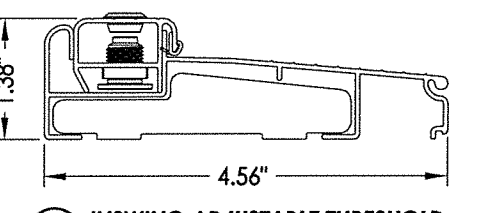

3 INSWING ADJUSTABLE THRESHOLD
ZAILAA4565

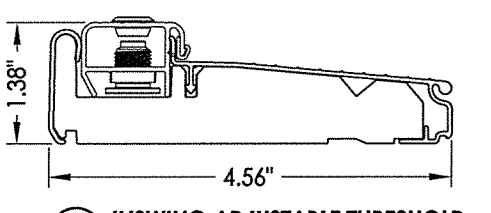

4 INSWING ADJUSTABLE THRESHOLD
ZAI4565RDS

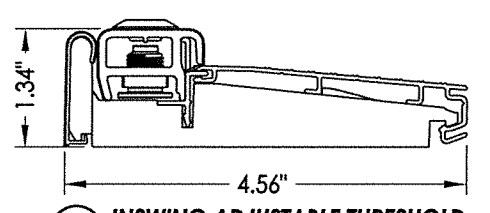

5 INSWING ADJUSTABLE THRESHOLD
ZAI4565RDS

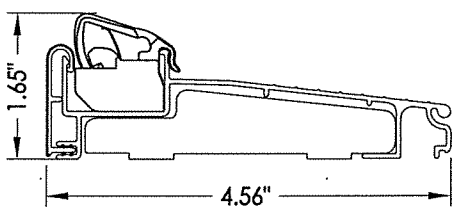

6 INSWING ARTICULATING THRESHOLD
ZACL4565

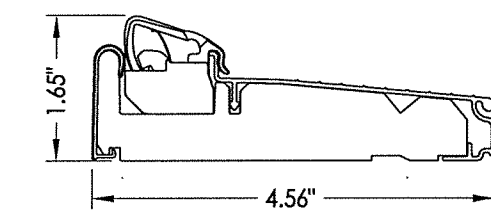

7 INSWING ARTICULATING THRESHOLD
ZAC4565FN

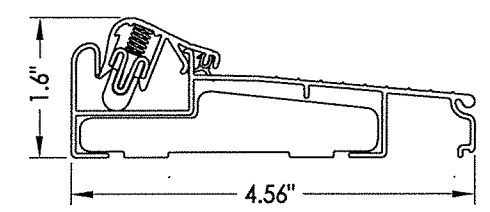

8 INSWING ARTICULATING THRESHOLD
ZACAA4565

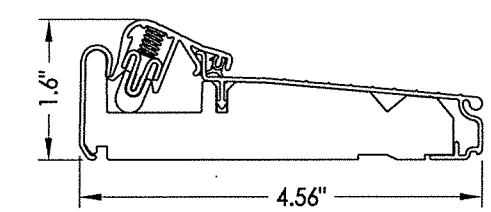

9 INSWING ARTICULATING THRESHOLD
ZACAA4565FN

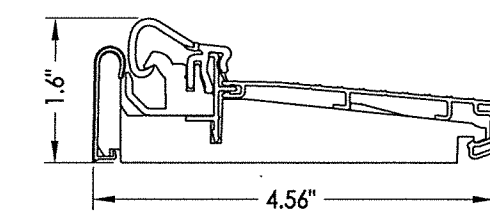

10 INSWING ARTICULATING THRESHOLD
ZAC4565RDS

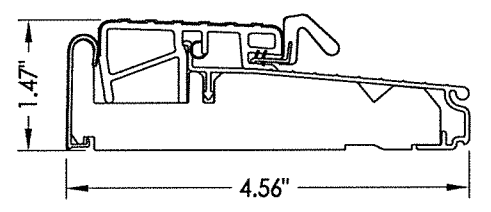

11 OUTSWING THRESHOLD
ZOB4565FN

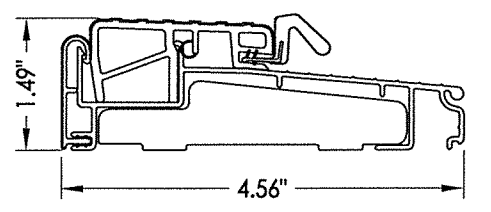

12 OUTSWING THRESHOLD
ZOBL4565

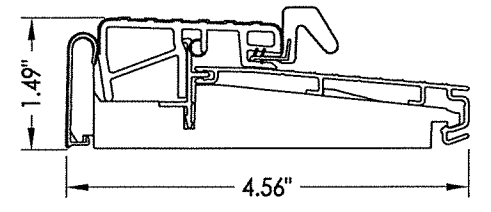

13 OUTSWING THRESHOLD
ZOB4565RDS

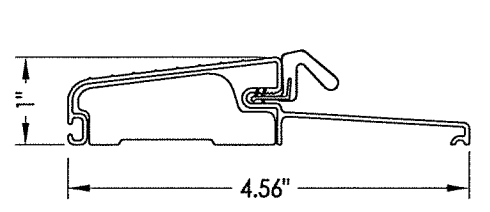

14 OUTSWING THRESHOLD
FOB4566

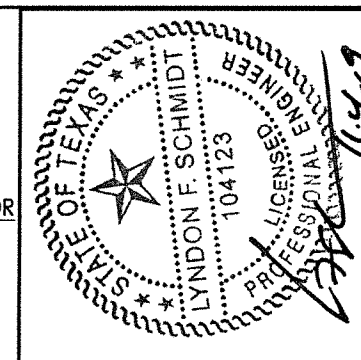

Documents Prepared By: Lyndon F. Schmidt, P.E.
TEXAS P.E. #104123

RW BUILDING CONSULTANTS, INC.
P.O. Box 230 Valrico FL 33595
Phone No.: 813.659.9197

TEXAS BOARD OF PROFESSIONAL ENGINEERS
CERTIFICATE OF REGISTRATION # F-11852

| | | |
|--|-------------------------|-----|
| PRODUCT: | ENDURA | |
| PART OR ASSEMBLY: | VERTICAL CROSS SECTIONS | |
| NO. | DATE | BY |
| 1 | 10/23/19 | LFS |
| ADD "FusionFrame" OPTION & UPDATE TO 2018 IBC/IRC CODE | | |
| REVISIONS | | |
| DATE: 11/16/16 | | |
| SCALE: N.T.S. | | |
| DWG. BY: JK | | |
| CHK. BY: LFS | | |
| DRAWING NO.: TX-4686 | | |
| SHEET 4 OF 5 | | |

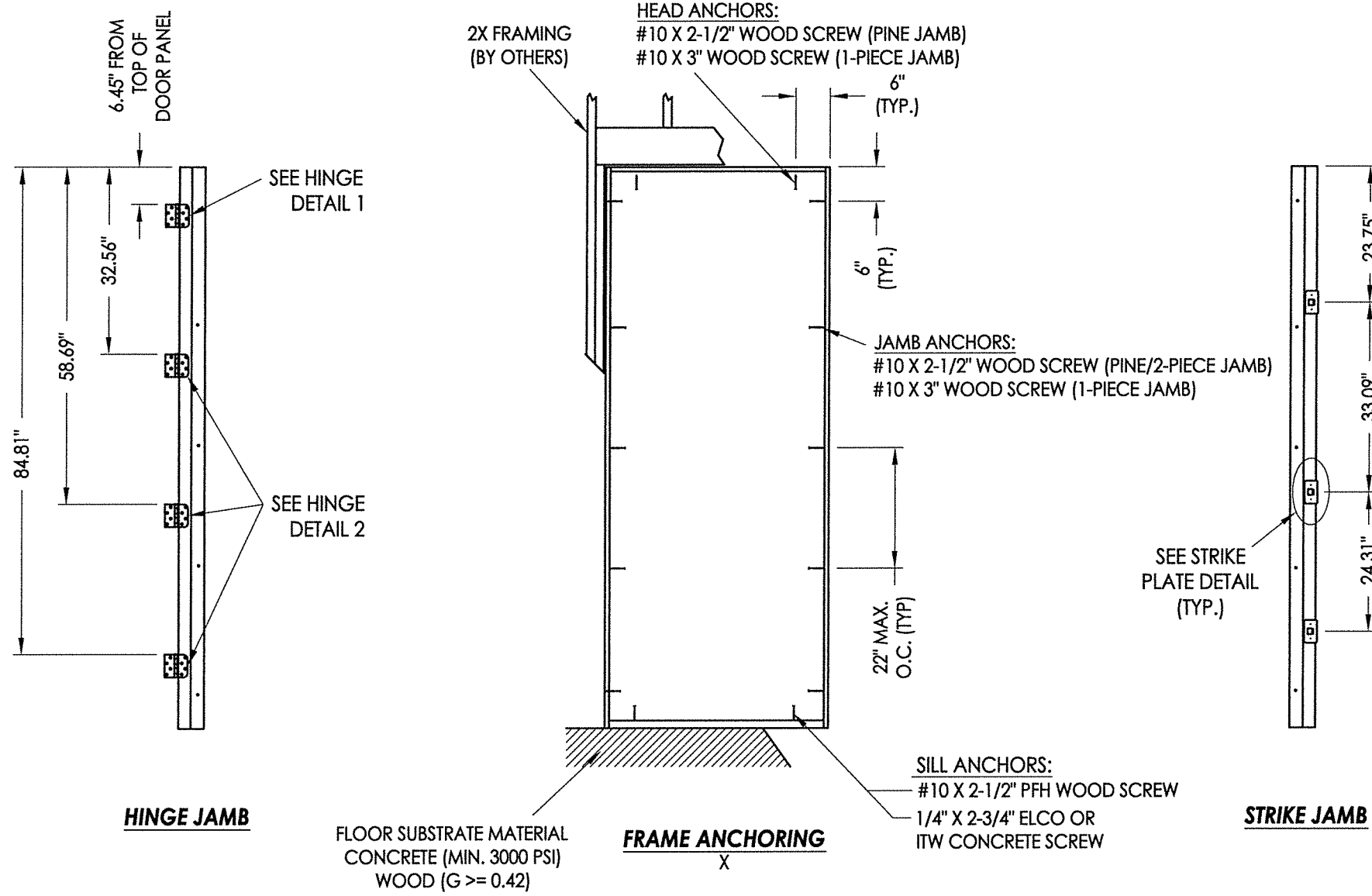

JAMB NOTES:

THE PINE OR "FusionFrame" 1-PIECE JAMB MAY BE INSTALLED @ THE HEAD OR SIDE JAMB.
THE FusionFrame" 2-PIECE JAMB MAY BE INSTALLED @ THE SIDE JAMBS ONLY.

CONCRETE ANCHOR NOTES:

- Concrete anchor locations at the corners may be adjusted to maintain the min. edge distance to mortar joints.
- Concrete anchor locations noted as "MAX. ON CENTER" must be adjusted to maintain the min. edge distance to mortar joints, additional concrete anchors may be required to ensure the "MAX. ON CENTER" dimension are not exceeded.
- Concrete anchor table:

| ANCHOR TYPE | ANCHOR SIZE | MIN. EMBEDMENT | MIN. CLEARANCE TO MASONRY EDGE | MIN. CLEARANCE TO ADJACENT ANCHOR |
|----------------|-------------|----------------|--------------------------------|-----------------------------------|
| ITW TAPCON® | 1/4" | 1-3/4" | 1-1/2" | 4" |
| ELCO ULTRACON® | 1/4" | 1-3/4" | 1" | 4" |

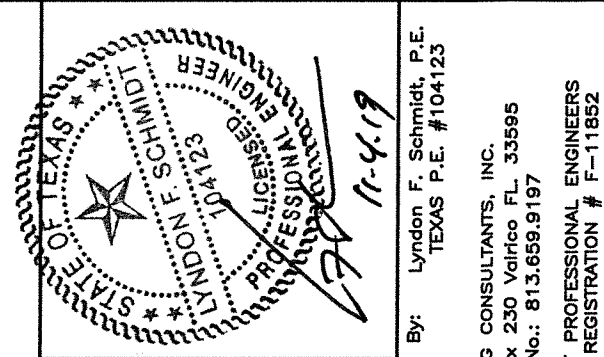
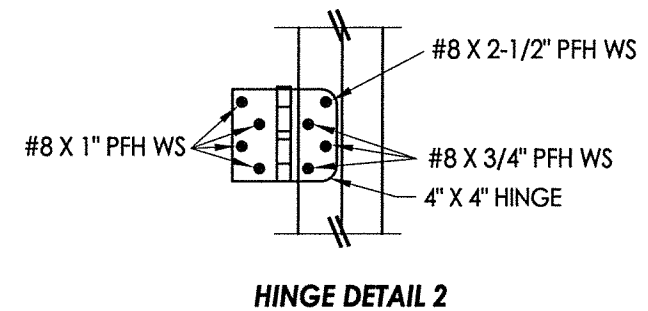
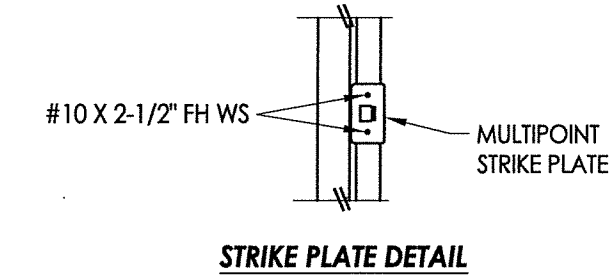
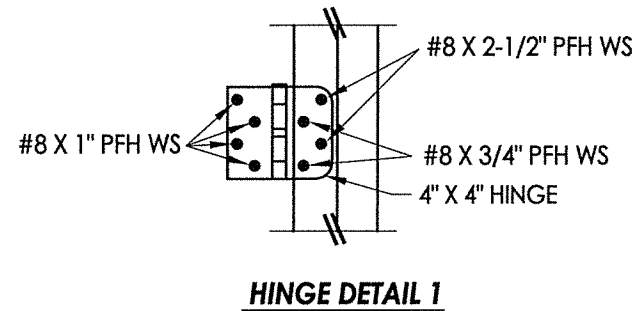

Documents Prepared By: Lyndon F. Schmidt, P.E.
TEXAS P.E. #104123

RW BUILDING CONSULTANTS, INC.
P.O. Box 230 Veirico FL 33595
Phone No.: 813.659.9197

TEXAS BOARD OF PROFESSIONAL ENGINEERS
CERTIFICATE OF REGISTRATION # F-11852

| | | |
|--|-----------------|------|
| PRODUCT: | ENDURA | |
| PART OR ASSEMBLY: | FRAME ANCHORING | |
| NO. | DATE | BY |
| 1 | 10/23/19 | LFS |
| ADD "FusionFrame" OPTION & UPDATE TO 2018 IBC/IRC CODE | | |
| REVISIONS | | |
| DATE: | 11/16/16 | |
| SCALE: | N.T.S. | |
| DWG. BY: | JK | |
| CHK. BY: | LFS | |
| DRAWING NO.: | TX-4686 | |
| SHEET | 5 | OF 5 |