

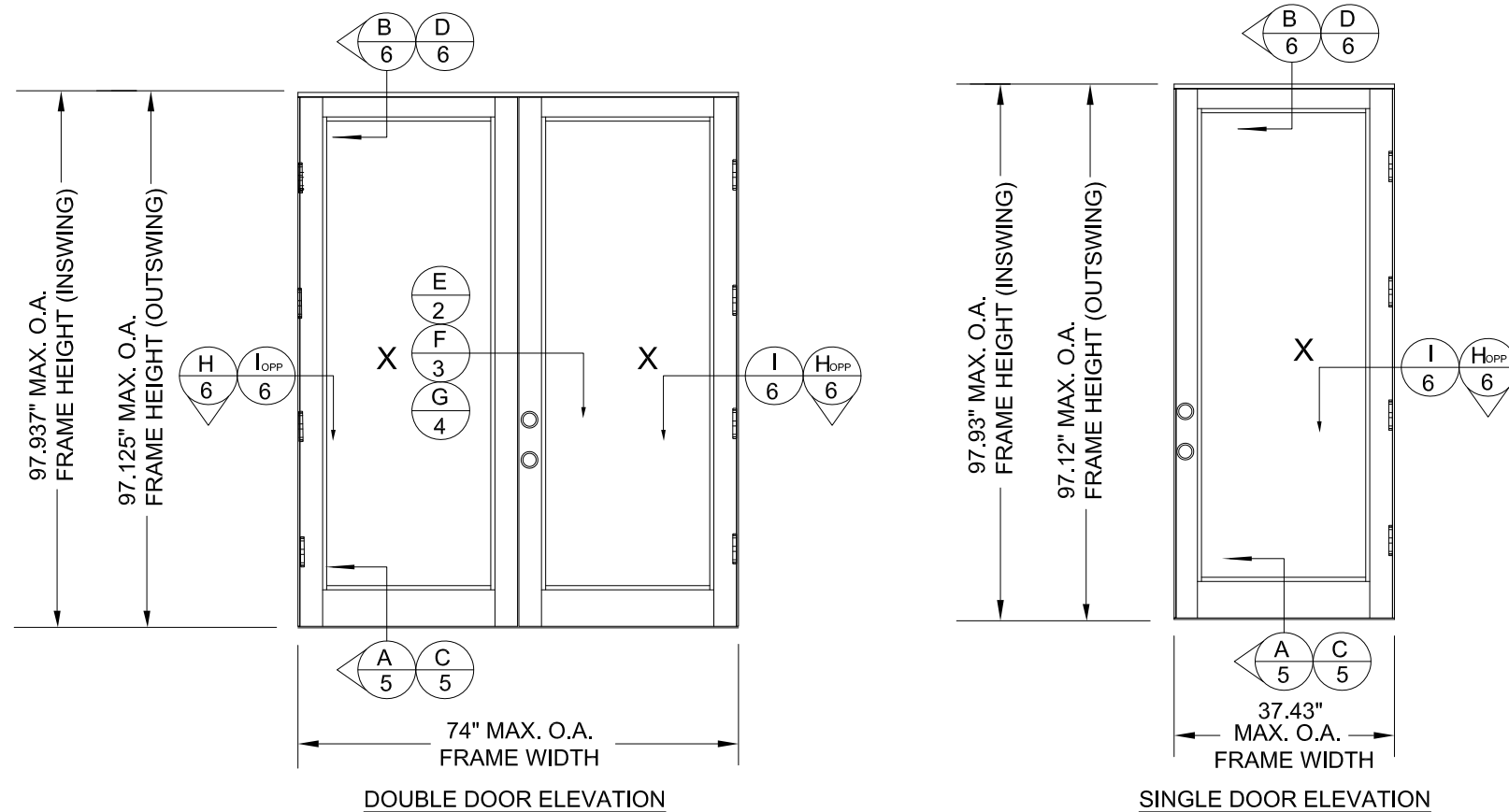

## PLASTPRO GLAZED 8'-0" FIBERGLASS DOOR XX AND X, INSWING / OUTSWING IMPACT

REVISIONS			
REV	DESCRIPTION	DATE	APPROVED
C	REVISED PER NEW CODE	11/10/2021	R.L.



### GENERAL NOTES:

1. THIS PRODUCT HAS BEEN EVALUATED AND IS IN COMPLIANCE WITH THE 2018 IBC AND 2018 IRC.
2. PRODUCT ANCHORS SHALL BE AS LISTED AND SPACED AS SHOWN ON DETAILS. ANCHOR EMBEDMENT TO BASE MATERIAL SHALL BE BEYOND WALL DRESSING.
3. INSTALLATION DETAILS DESCRIBED HEREIN ARE GENERIC AND MAY NOT REFLECT ACTUAL CONDITIONS FOR A SPECIFIC SITE. IF INSTALLATION METHODS DEVIATE FROM THESE APPROVED DETAILS FURTHER INVESTIGATION BY A LICENSED REGISTERED DESIGN PROFESSIONAL IS REQUIRED.
4. ADEQUACY OF EXISTING STRUCTURAL CONCRETE / MASONRY AND 2X FRAMING PER INSTALLATION AS A MAIN WIND FORCE RESISTING SYSTEM CAPABLE OF WITHSTANDING AND TRANSFERRING APPLIED PRODUCT LOADS TO FOUNDATION IS RESPONSIBILITY OF ENGINEER OR ARCHITECT OF RECORD.
5. THIS PRODUCT IS IMPACT RATED AND DOES NOT REQUIRE IMPACT PROTECTION IN WIND BORNE DEBRIS REGIONS.
6. 1X BUCK OVER MASONRY/CONCRETE IS OPTIONAL. WHERE 1X BUCK IS NOT USED DISSIMILAR MATERIALS MUST BE SEPARATED WITH APPROVED COATING OR MEMBRANE. SELECTION OF COATING OR MEMBRANE IS THE RESPONSIBILITY OF THE ARCHITECT OR ENGINEER OF RECORD.
7. APPROVED CONFIGURATIONS: XX, X.

Configuration	Frame size (in)	Design pressure rating (psf)	Impact rating
In-swing XX	74" x 97.937"	+45.0 -45.0	Large and Small
Out-swing XX	74" x 97.125"	+45.0 -45.0	
In-swing X	37.43" x 97.93"	+45.0 -45.0	Missile
Out-swing X	37.43" x 97.12"	+45.0 -45.0	

Plastpro fiberglass insert glazed panels SMC 0.140" skin  
Refer to sheets 2, 3 & 4 for all hardware options  
Refer to sheet 5 for impact glazing insert options

TABLE OF CONTENTS	
SHEET	SHEET DESCRIPTION
1	ELEVATION AND GENERAL NOTES
2 - 4	ASTRAGAL & LOCK DETAILS
5	SILL AND GLAZING DETAILS
6	VERTICAL & HORIZONTAL CROSS SECTIONS
7 - 8	ANCHOR ELEVATIONS AND NOTES
9	COMPONENTS AND BILL OF MATERIALS

ENDURA PRODUCTS, INC.  
8817 WEST MARKET STREET  
COLFAX, NC 27235

PLASTPRO GLAZED  
FIBERGLASS DOORS  
ELEVATION AND GENERAL NOTES

DRAWN: RM DWG NO. NL-0014 REV C

SCALE NTS DATE 07/30/13 SHEET 1 OF 9

L. ROBERTO LOMAS P.E.  
1432 WOODFORD RD LEWISVILLE, NC 27023  
434-688-0609 rllomas@lrlomaspe.com

SIGNED: 11/10/2021



Luis R. Lomas P.E.  
TX No.: 101889

REVISIONS			
REV	DESCRIPTION	DATE	APPROVED
C	REVISED PER NEW CODE	11/10/2021	R.L.

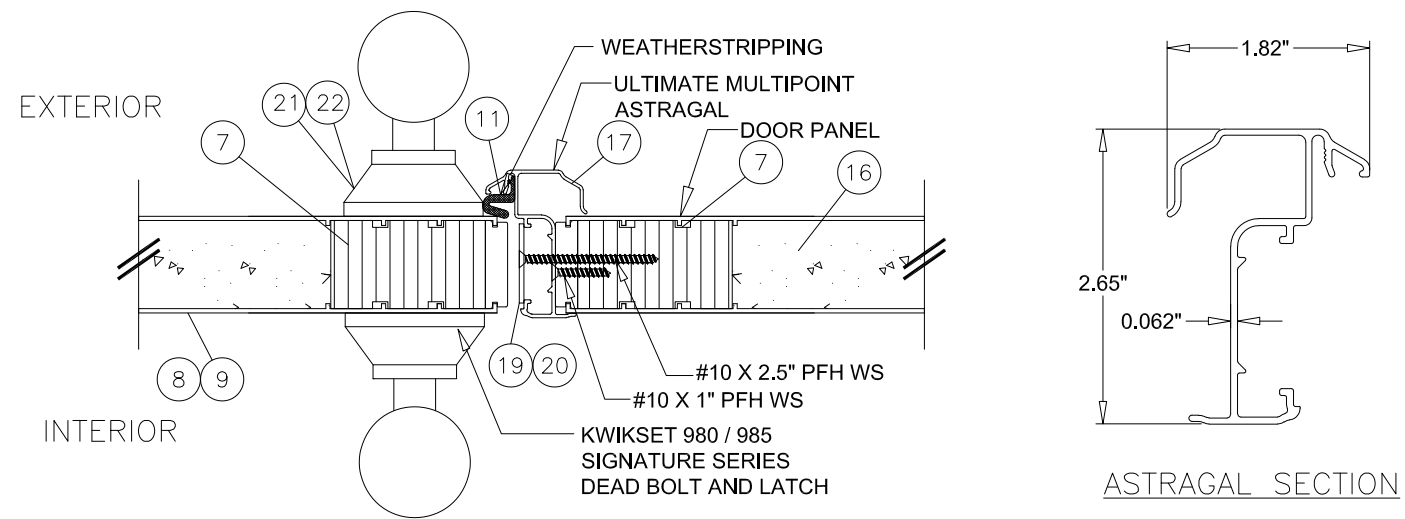
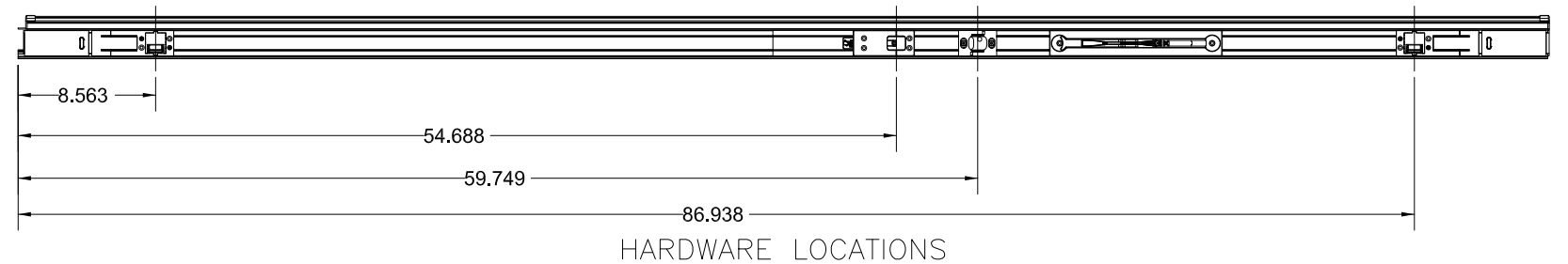
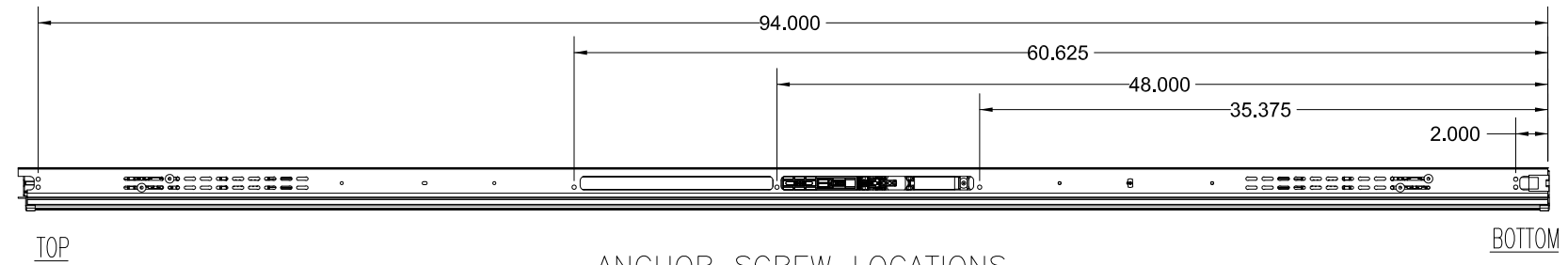
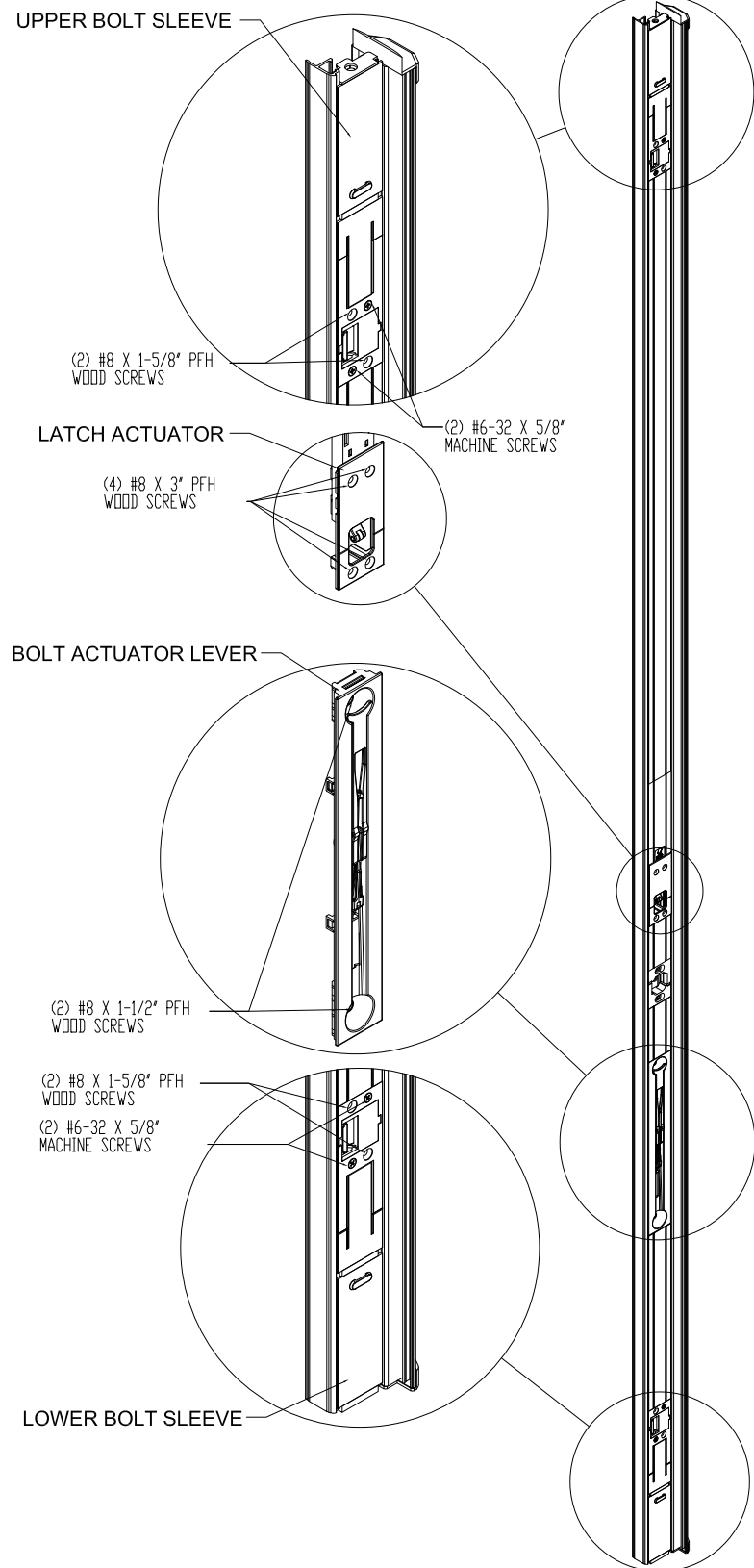

E ASTRAGAL SECTION  
2 INSWING SHOWN-OUTSWING SIMILAR

SIGNED: 11/10/2021

ENDURA PRODUCTS, INC.  
8817 WEST MARKET STREET  
COLFAX, NC 27235

PLASTPRO GLAZED  
FIBERGLASS DOORS  
ASTRAGAL AND LOCK SET DETAILS

DRAWN: RM	DWG NO. NL-0014	REV C
SCALE NTS	DATE 07/30/13	SHEET 2 OF 9

L. ROBERTO LOMAS P.E.  
1432 WOODFORD RD LEWISVILLE, NC 27023  
434-688-0609 rllomas@lrlomaspe.com



Luis R. Lomas P.E.  
TX No.: 101889

REVISIONS			
REV	DESCRIPTION	DATE	APPROVED
C	REVISED PER NEW CODE	11/10/2021	R.L.

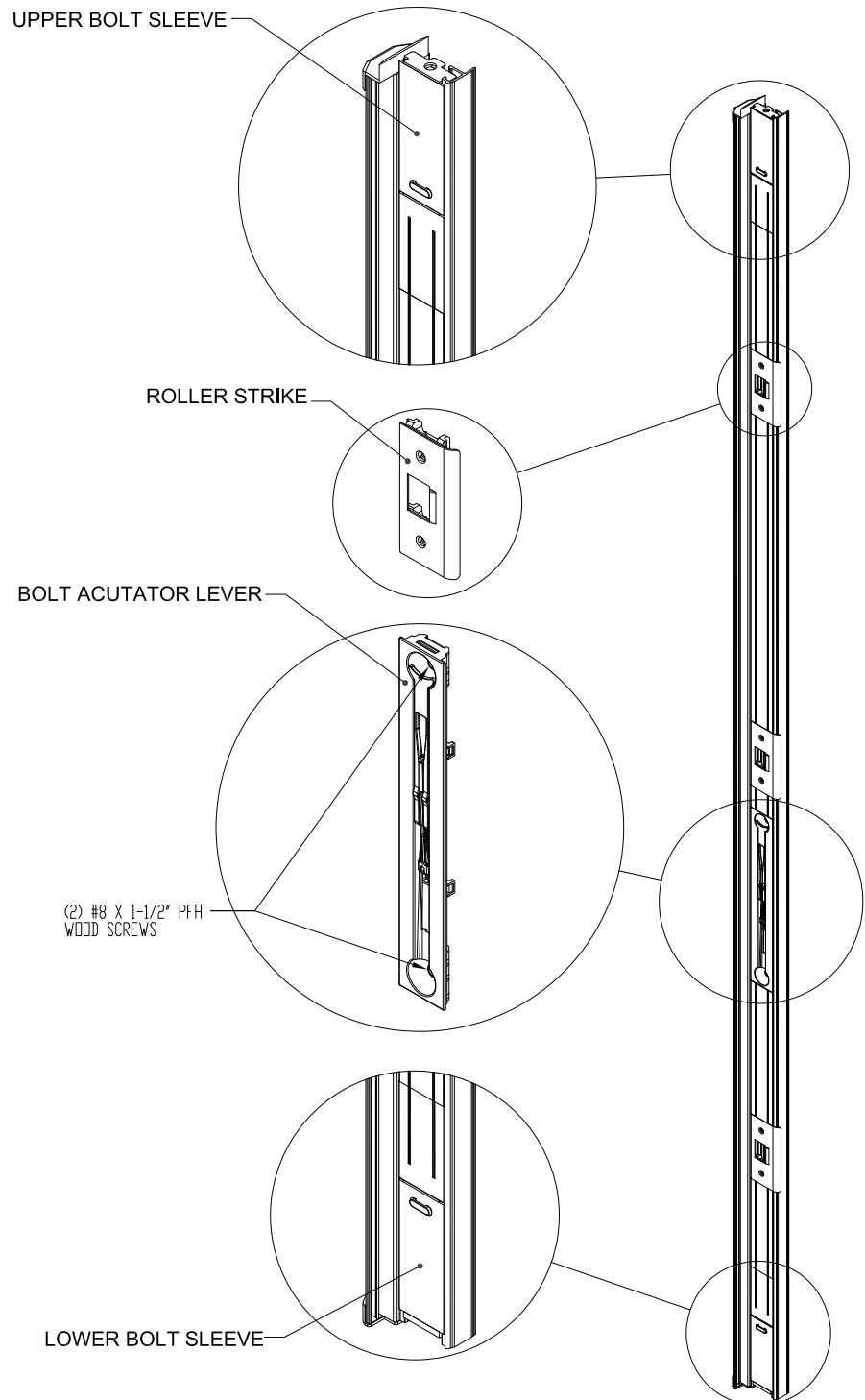

ULTIMATE TRIENNIMUM ASTRAGAL

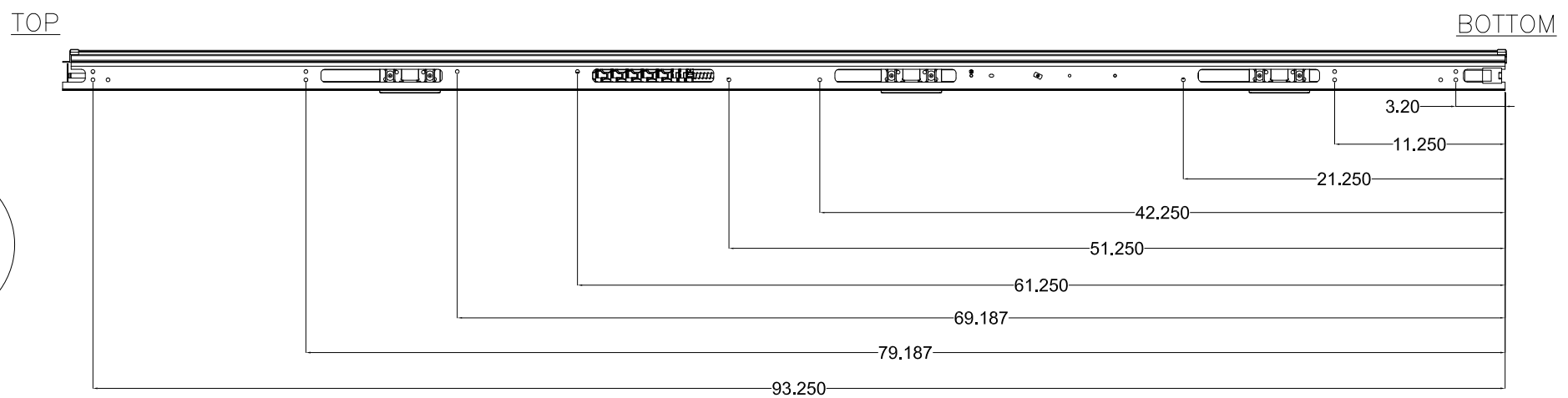

ANCHOR SCREW LOCATIONS

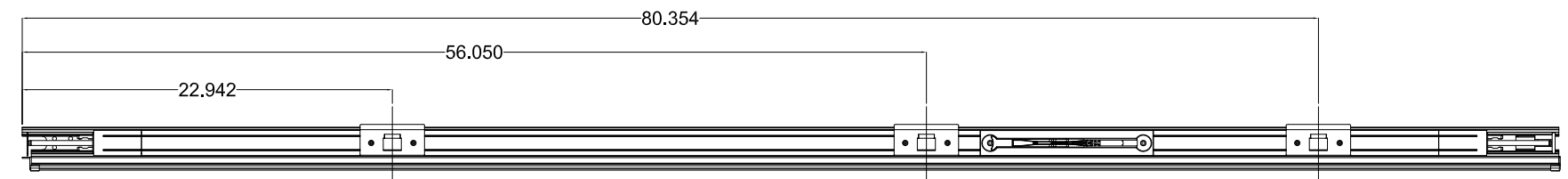

HARDWARE LOCATIONS

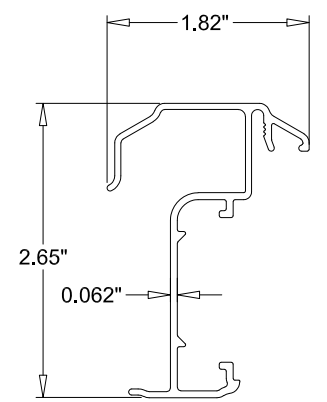
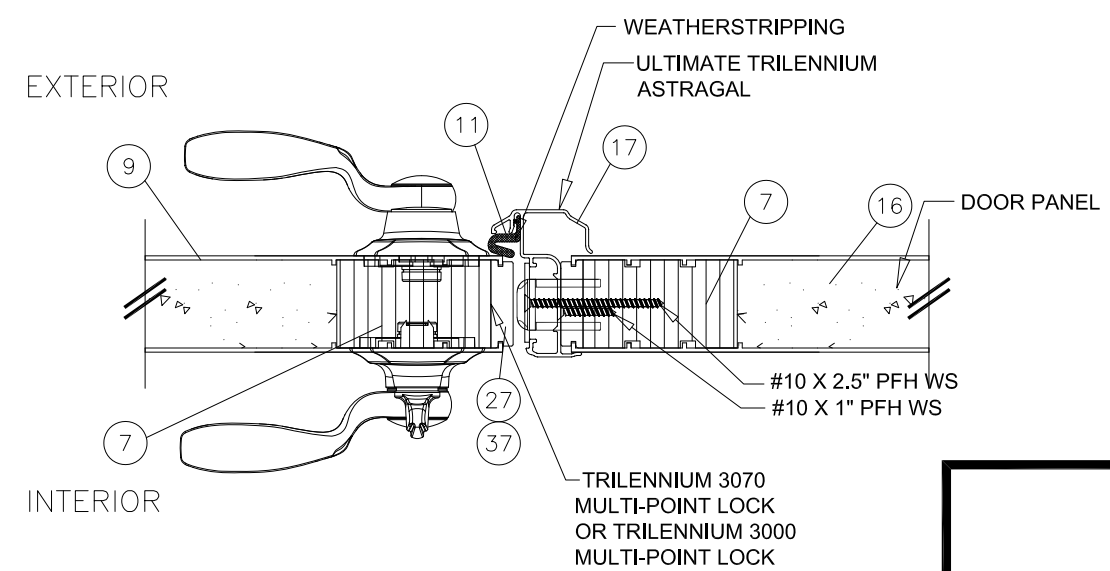

ASTRAGAL SECTION

F  
3 ASTRAGAL SECTION  
INSWING SHOWN-OUTSWING SIMILAR

SIGNED: 11/10/2021

ENDURA PRODUCTS, INC.  
8817 WEST MARKET STREET  
COLFAX, NC 27235

PLASTPRO GLAZED  
FIBERGLASS DOORS  
ASTRAGAL AND LOCK SET DETAILS

DRAWN: RM	DWG NO. NL-0014	REV C
SCALE NTS	DATE 07/30/13	SHEET 3 OF 9

L. ROBERTO LOMAS P.E.  
1432 WOODFORD RD LEWISVILLE, NC 27023  
434-688-0609 rllomas@rlomaspe.com



Luis R. Lomas P.E.  
TX No.: 101889

REVISIONS			
REV	DESCRIPTION	DATE	APPROVED
C	REVISED PER NEW CODE	11/10/2021	R.L.

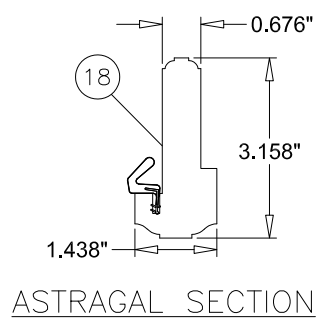
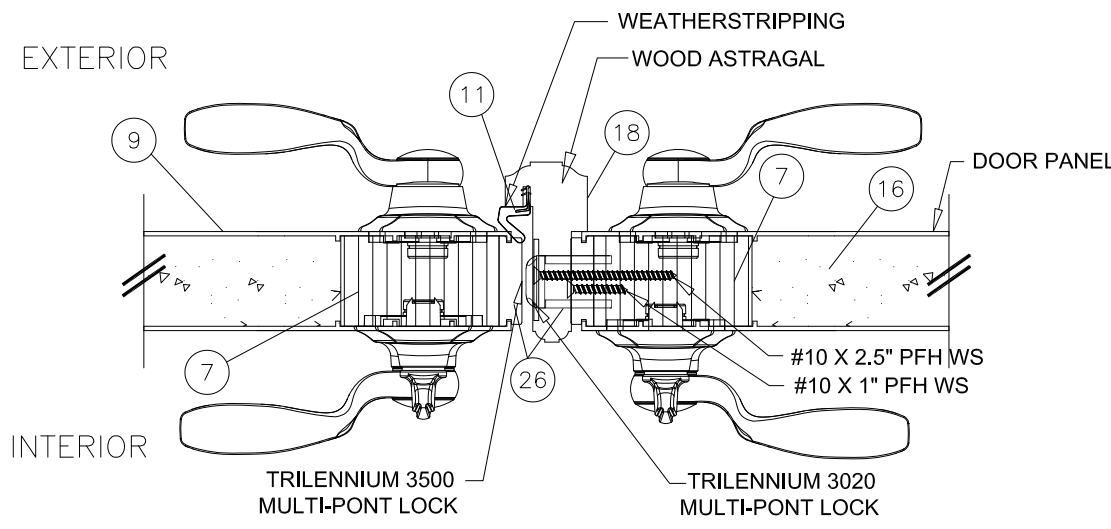
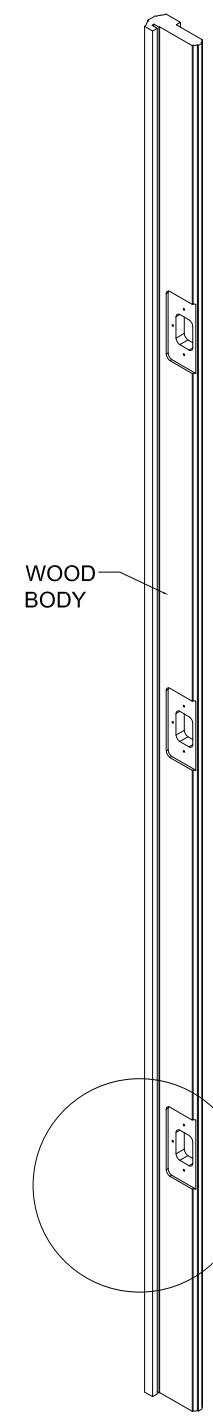
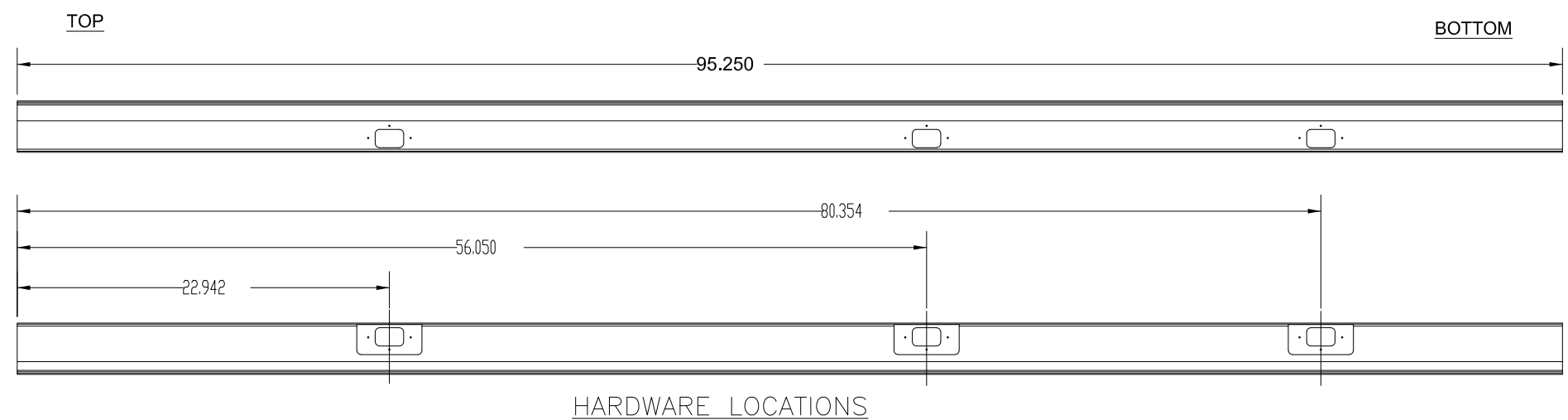

G  
4 ASTRAGAL SECTION  
INSWING SHOWN-OUTSWING SIMILAR

WOOD ASTRAGAL

SIGNED: 11/10/2021

ENDURA PRODUCTS, INC.  
8817 WEST MARKET STREET  
COLFAX, NC 27235

PLASTPRO GLAZED  
FIBERGLASS DOORS  
ASTRAGAL AND LOCK SET DETAILS

DRAWN: RM	DWG NO. NL-0014	REV C
SCALE NTS	DATE 07/30/13	SHEET 4 OF 9

L. ROBERTO LOMAS P.E.  
1432 WOODFORD RD LEWISVILLE, NC 27023  
434-688-0609 rllomas@lrlomaspe.com



Luis R. Lomas P.E.  
TX No.: 101889

REVISIONS			
REV	DESCRIPTION	DATE	APPROVED
C	REVISED PER NEW CODE	11/10/2021	R.L.

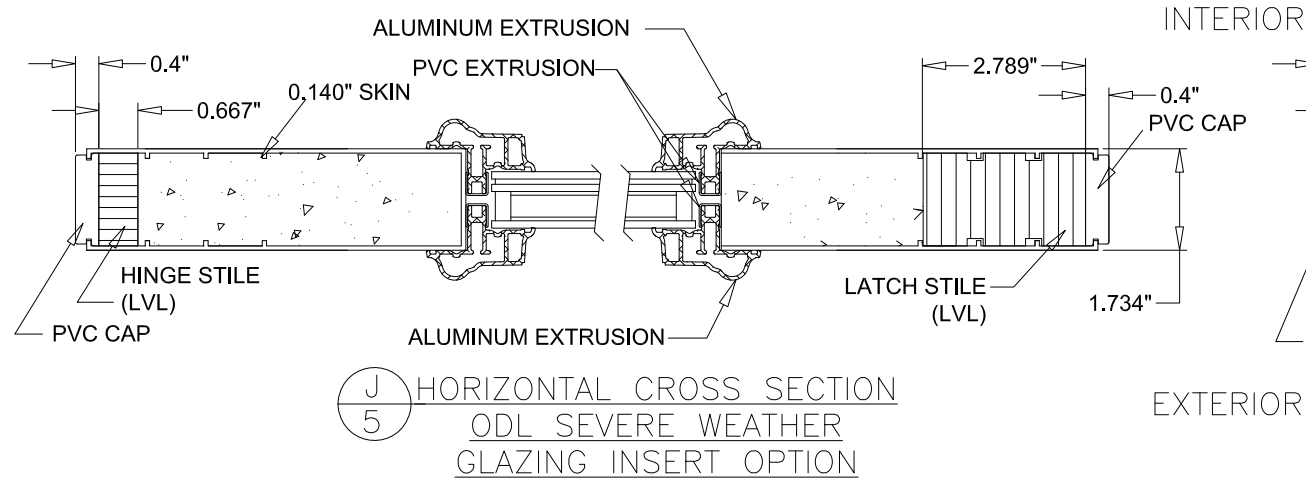

**J**  
5 HORIZONTAL CROSS SECTION  
ODL SEVERE WEATHER  
GLAZING INSERT OPTION

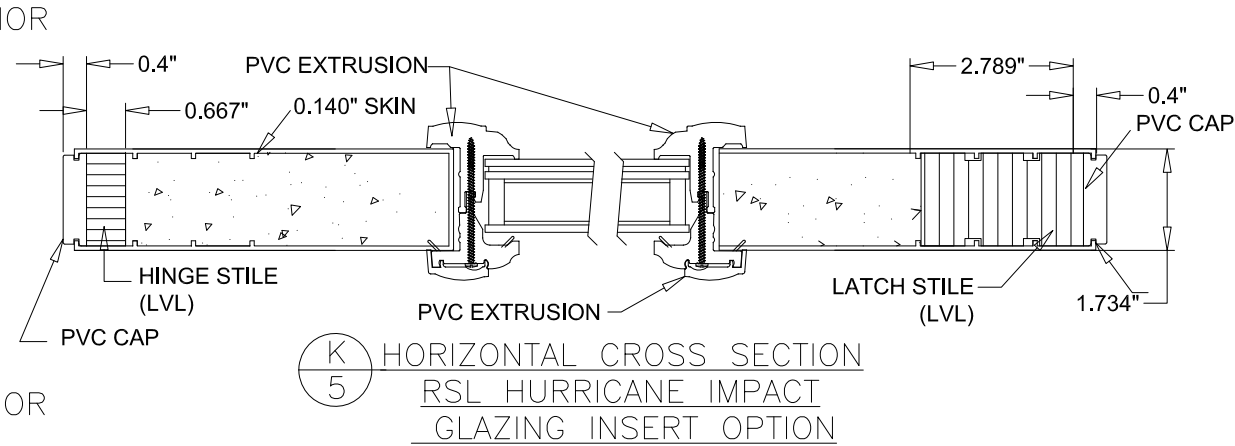

**K**  
5 HORIZONTAL CROSS SECTION  
RSL HURRICANE IMPACT  
GLAZING INSERT OPTION

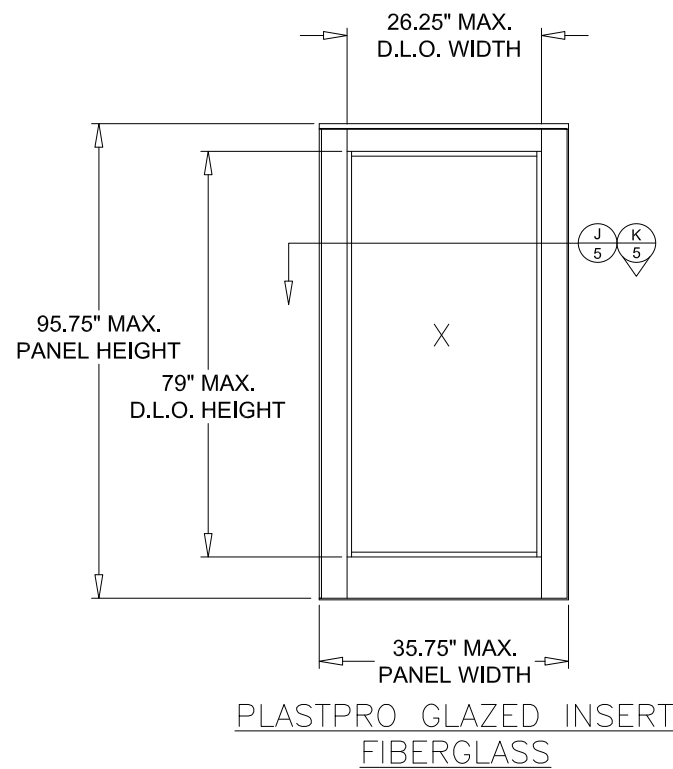

PLASTPRO GLAZED INSERT  
FIBERGLASS

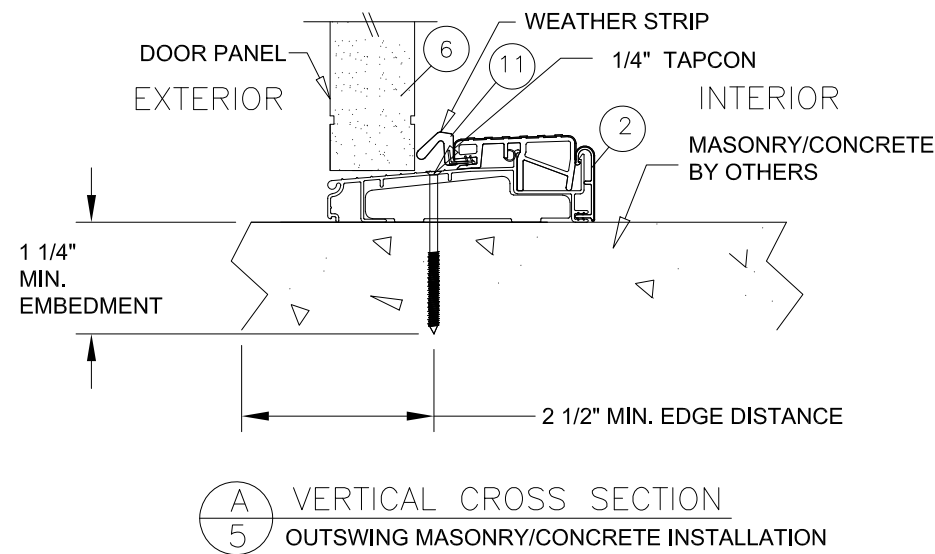

**A**  
5 VERTICAL CROSS SECTION  
OUTSWING MASONRY/CONCRETE INSTALLATION

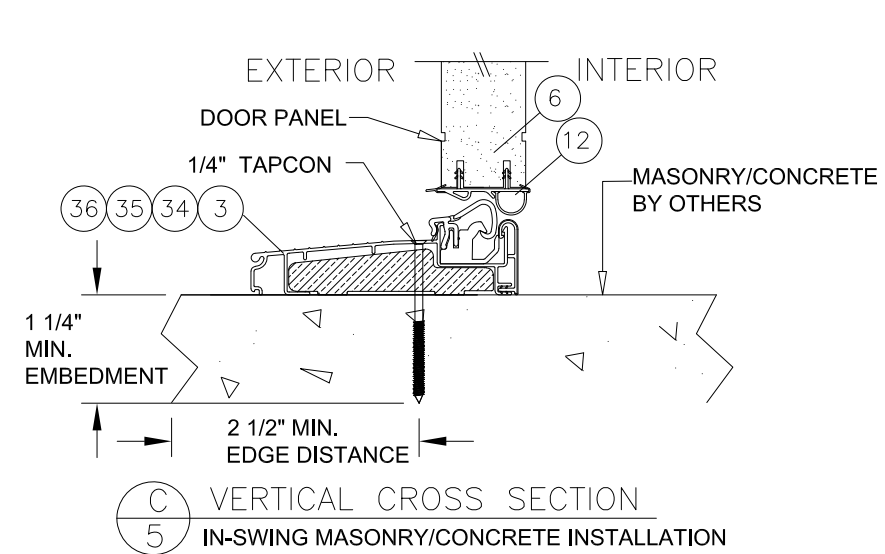

**C**  
5 VERTICAL CROSS SECTION  
IN-SWING MASONRY/CONCRETE INSTALLATION

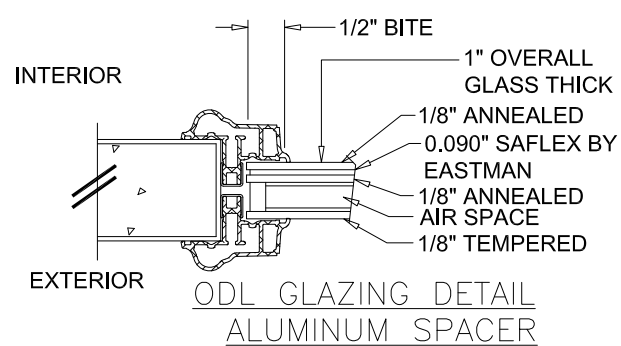

ODL GLAZING DETAIL  
ALUMINUM SPACER

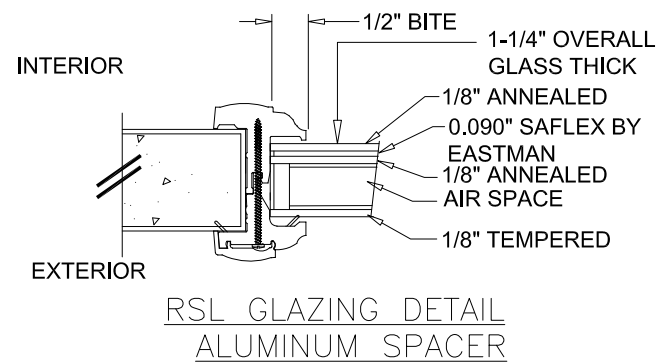

RSL GLAZING DETAIL  
ALUMINUM SPACER

ENDURA PRODUCTS, INC.  
8817 WEST MARKET STREET  
COLFAX, NC 27235

PLASTPRO GLAZED  
FIBERGLASS DOORS  
GLAZING INSERT AND SILL DETAILS

DRAWN: RM	DWG NO. NL-0014	REV C
SCALE NTS	DATE 07/30/13	SHEET 5 OF 9

L. ROBERTO LOMAS P.E.  
1432 WOODFORD RD LEWISVILLE, NC 27023  
434-688-0609 rllomas@lrlomaspe.com

SIGNED: 11/10/2021



Luis R. Lomas P.E.  
TX No.: 101889

REVISIONS			
REV	DESCRIPTION	DATE	APPROVED
C	REVISED PER NEW CODE	11/10/2021	R.L.

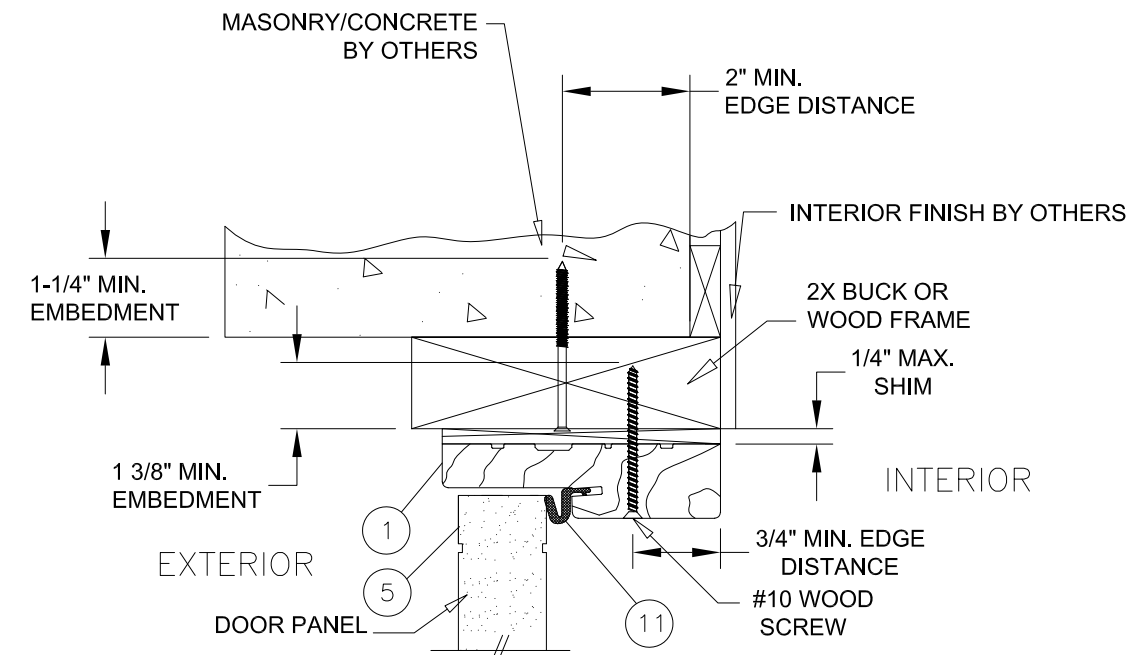
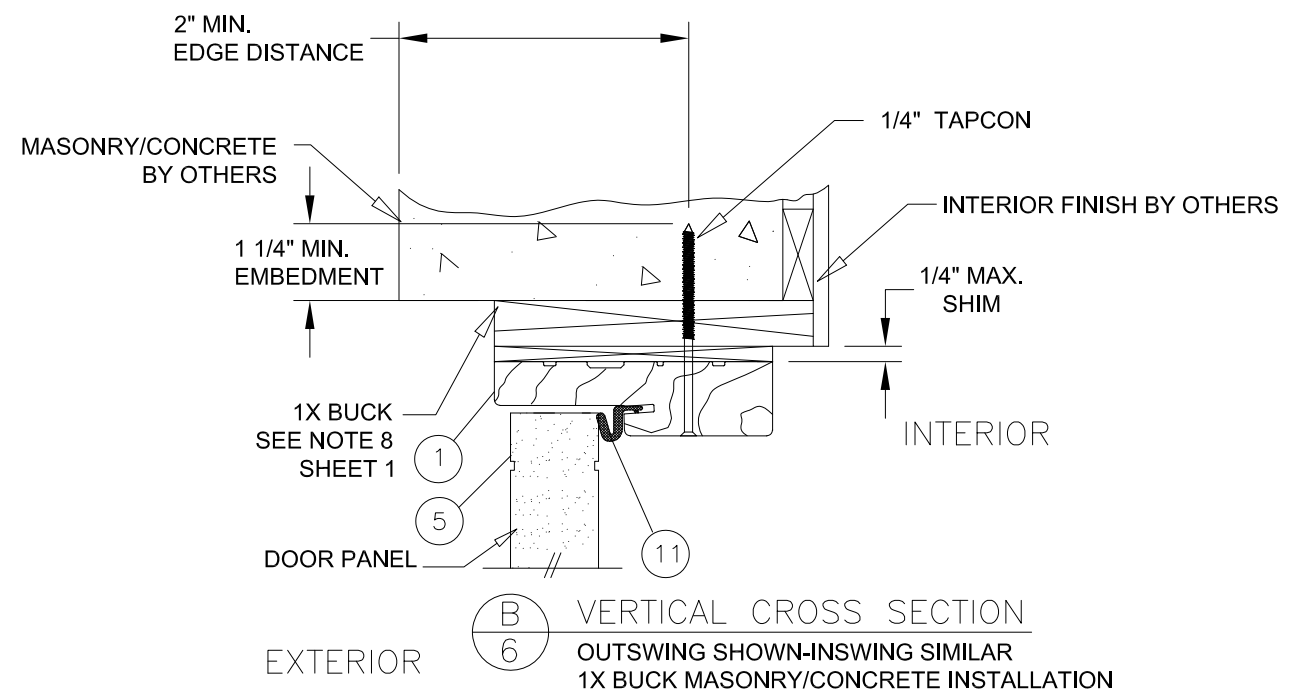

**B**  
**6** VERTICAL CROSS SECTION  
OUTSWING SHOWN-INSWING SIMILAR  
1X BUCK MASONRY/CONCRETE INSTALLATION

**D**  
**6** VERTICAL CROSS SECTION  
OUTSWING SHOWN-INSWING SIMILAR  
2X BUCK OR WOOD FRAME INSTALLATION

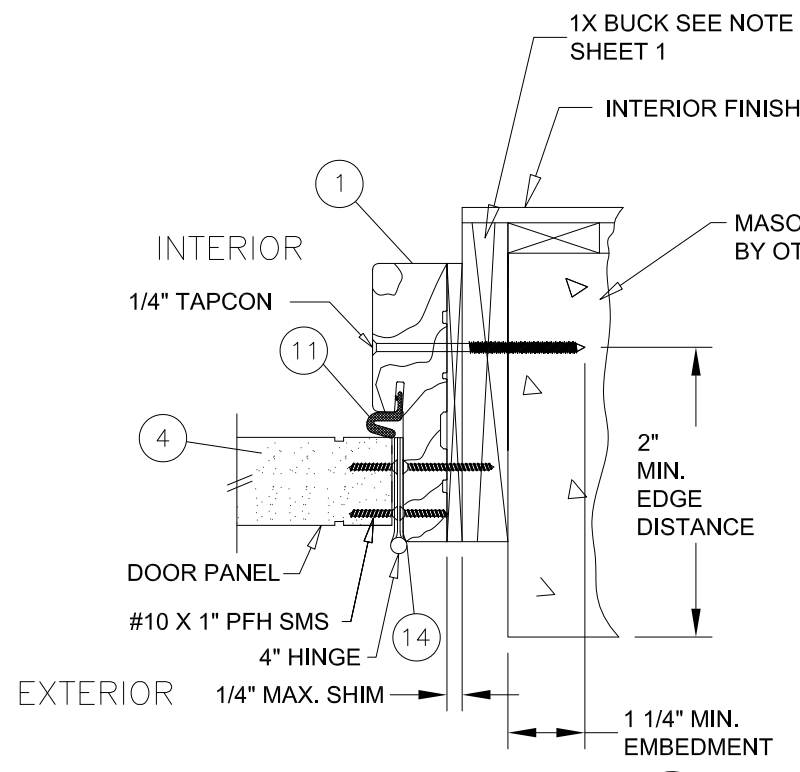
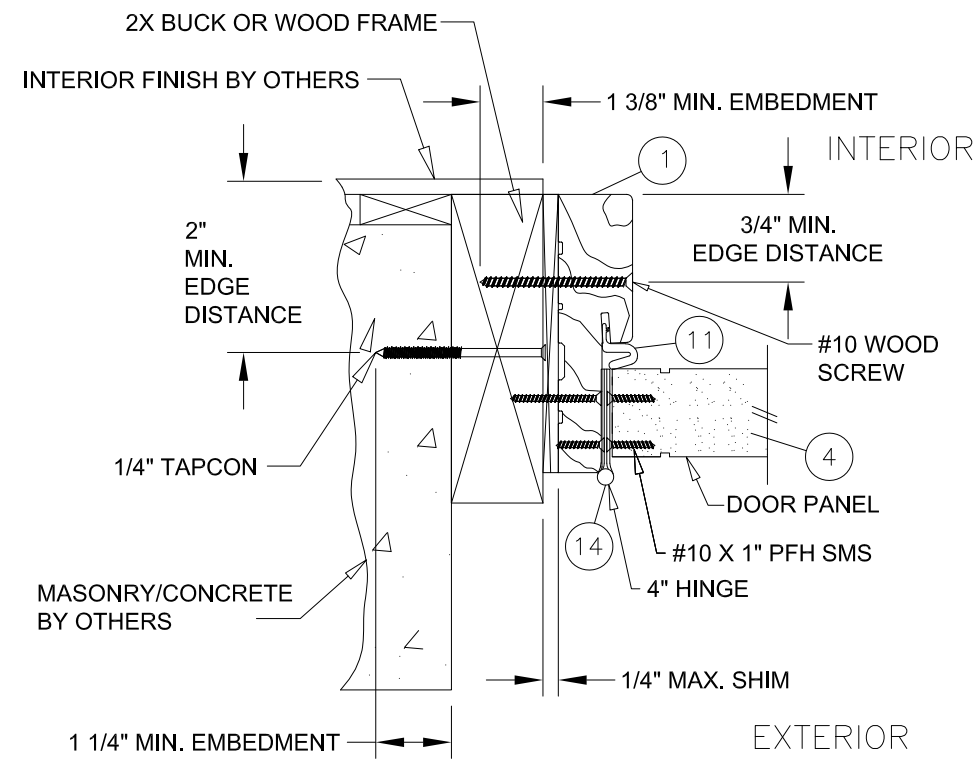

**H**  
**6** HORIZONTAL CROSS SECTION  
OUTSWING SHOWN-INSWING SIMILAR  
2X BUCK OR WOOD FRAME INSTALLATION

**I**  
**6** HORIZONTAL CROSS SECTION  
OUTSWING SHOWN-INSWING SIMILAR  
1X BUCK MASONRY/CONCRETE INSTALLATION

SIGNED: 11/10/2021

ENDURA PRODUCTS, INC.  
8817 WEST MARKET STREET  
COLFAX, NC 27235

PLASTPRO GLAZED  
FIBERGLASS DOORS  
DOOR CROSS SECTIONS

DRAWN: RM	DWG NO. NL-0014	REV C
SCALE NTS	DATE 07/30/13	SHEET 6 OF 9

L. ROBERTO LOMAS P.E.  
1432 WOODFORD RD LEWISVILLE, NC 27023  
434-688-0609 rllomas@rlomaspe.com



Luis R. Lomas P.E.  
TX No.: 101889

REVISIONS			
REV	DESCRIPTION	DATE	APPROVED
C	REVISED PER NEW CODE	11/10/2021	R.L.

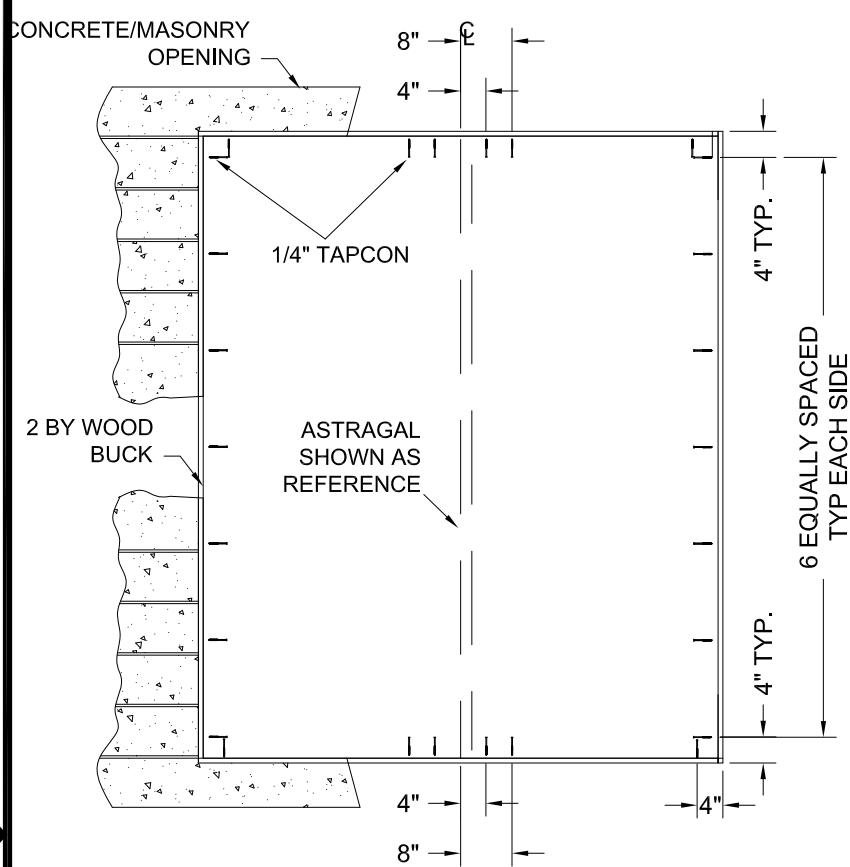

**WOOD BUCK TO  
SUBSTRATE ANCHORING  
XX**

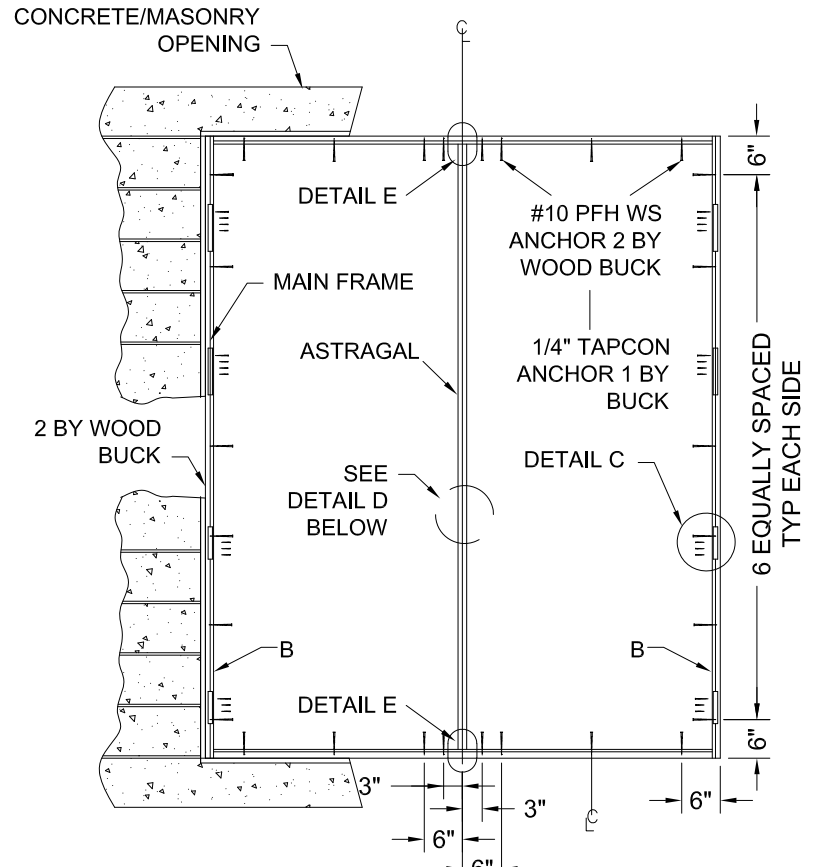

**MAIN FRAME TO  
BUCK ANCHORING  
XX**

**INSTALLATION NOTES:**

- ONE (1) INSTALLATION ANCHOR IS REQUIRED AT EACH ANCHOR LOCATION SHOWN.
- THE NUMBER OF INSTALLATION ANCHORS DEPICTED IS THE MINIMUM NUMBER OF ANCHORS TO BE USED FOR PRODUCT INSTALLATION. ANCHORS ARE TO MATCH TYPE, SIZE, AND EMBEDMENT OF THOSE SHOWN HEREIN FOR RESPECTIVE SUBSTRATE.
- SHIM AS REQUIRED AT EACH INSTALLATION ANCHOR WITH LOAD BEARING SHIM(S). MAXIMUM ALLOWABLE SHIM SIZE IS 1/4 INCH. SHIM WHERE SPACE OF 1/8 INCH OR GREATER OCCURS. SHIM(S) SHALL BE CONSTRUCTED OF HIGH DENSITY PLASTIC OR BETTER.
- FOR INSTALLATION INTO WOOD FRAMING, USE #10 WOOD SCREWS OF SUFFICIENT LENGTH TO ACHIEVE 1 3/8" MINIMUM EMBEDMENT.
- FOR INSTALLATION THROUGH 1X BUCK TO CONCRETE / MASONRY, OR DIRECTLY INTO CONCRETE / MASONRY, USE 1/4 TAPCON OF SUFFICIENT LENGTH TO ACHIEVE 1 1/4" MINIMUM EMBEDMENT WITH A 2" MINIMUM EDGE DISTANCE.
- ALTERNATE CONCRETE / MASONRY INSTALLATION ANCHORS OF EQUIVALENT PERFORMANCE CHARACTERISTICS CAN BE USED UPON APPROVAL OF ARCHITECT OR ENGINEER OF RECORD FOR THE PROJECT OF INSTALLATION.
- MINIMUM EMBEDMENT AND EDGE DISTANCE EXCLUDE WALL FINISHES (INCLUDING BUT NOT LIMITED TO STUCCO, FOAM, BRICK VENEER, AND SIDING).
- INSTALLATION ANCHOR CAPACITIES FOR PRODUCTS SHOWN HEREIN ARE BASED ON SUBSTRATE MATERIALS WITH THE FOLLOWING PROPERTIES:
  - A. WOOD - MINIMUM SPECIFIC GRAVITY OF 0.42.
  - B. CONCRETE - MINIMUM COMPRESSIVE STRENGTH OF 3192 PSI.
  - C. MASONRY - STRENGTH CONFORMANCE TO ASTM C-90, GRADE N, TYPE 1 (OR GREATER).

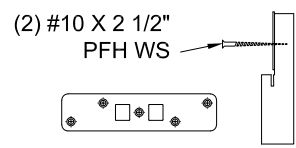
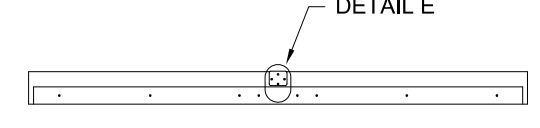
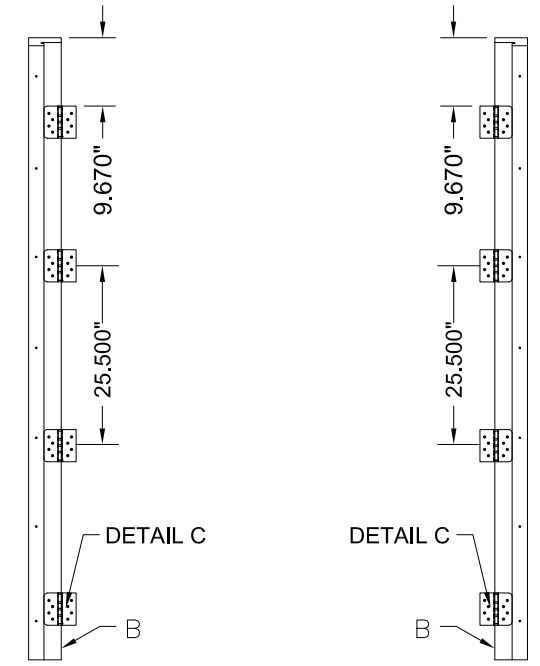
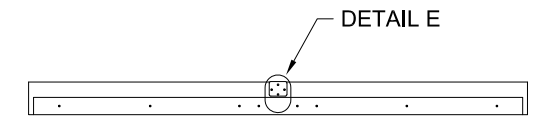

**HEAD/SILL STRIKE PLATE DETAIL**  
3500 / 3020 TRILENNIUM  
ATTACH LOCK THROW BOLT  
STRIKE PLATE TO FRAME  
AS SHOWN.

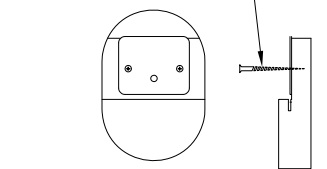

**HEAD STRIKE PLATE DETAIL**  
ULTIMATE MPA ASTRAGAL  
ATTACH ASTRAGAL THROW BOLT  
STRIKE PLATE TO FRAME  
AS SHOWN.

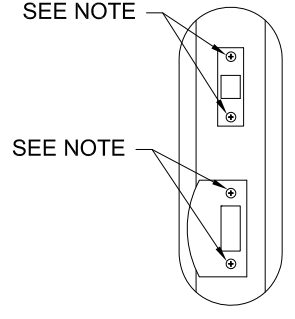

**DETAIL D**  
NOTE:  
ATTACH STRIKE & DEADBOLT  
PLATES TO STRIKE & BUCK  
WITH #10 X 2" FH WOOD SCREW  
ATTACH STRIKE & DEAD BOLT  
PLATES TO ASTRAGAL WITH  
#8 X 2 1/2" FH WOOD SCREWS  
ATTACH STRIKE TO JAMB &  
SIDELITE JAMB WITH #10 X 1 3/4"  
FH WOOD SCREW.

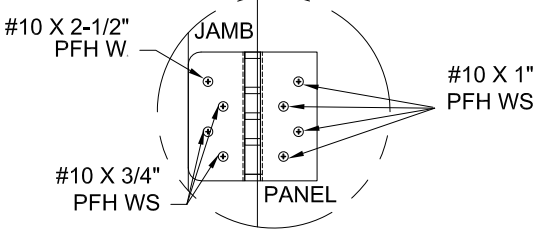

**HINGE DETAIL**

**ENDURA PRODUCTS, INC.**  
8817 WEST MARKET STREET  
COLFAX, NC 27235

PLASTPRO GLAZED  
FIBERGLASS DOORS  
ELEVATION AND ANCHOR LAYOUT

DRAWN: RM	DWG NO. NL-0014	REV C
SCALE NTS	DATE 07/30/13	SHEET 7 OF 9

L. ROBERTO LOMAS P.E.  
1432 WOODFORD RD LEWISVILLE, NC 27023  
434-688-0609 rllomas@rlomaspe.com

SIGNED: 11/10/2021



Luis R. Lomas P.E.  
TX No.: 101889

REVISIONS			
REV	DESCRIPTION	DATE	APPROVED
C	REVISED PER NEW CODE	11/10/2021	R.L.

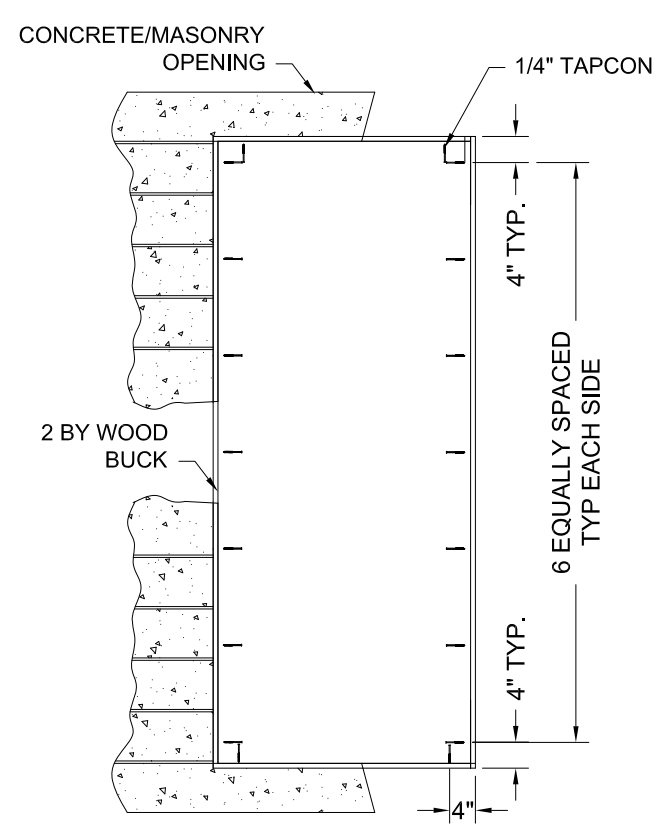

**WOOD BUCK TO  
SUBSTRATE ANCHORING**  
X

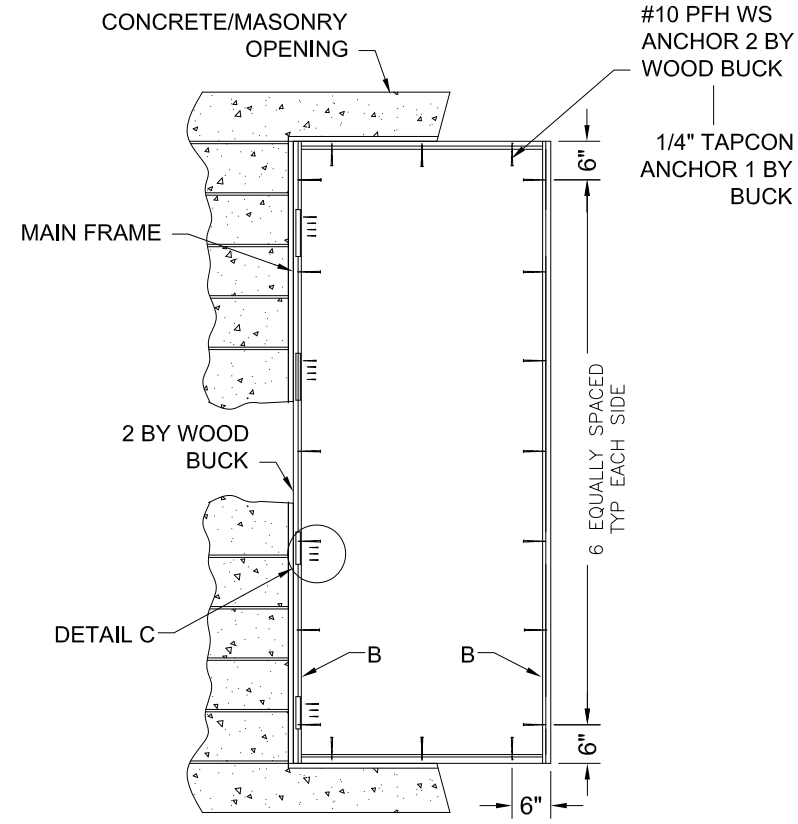

**MAIN FRAME TO  
BUCK ANCHORING**  
X

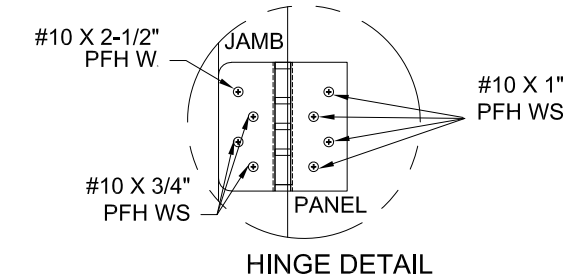
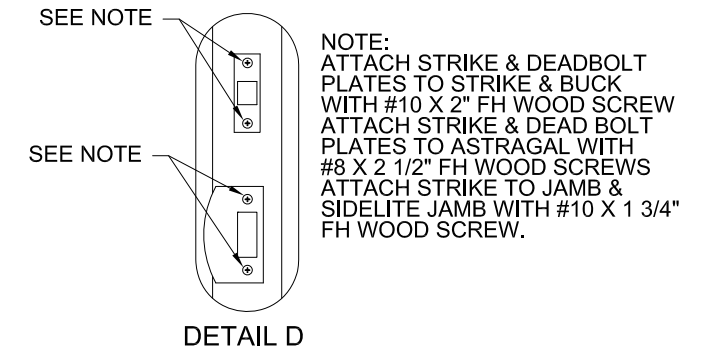
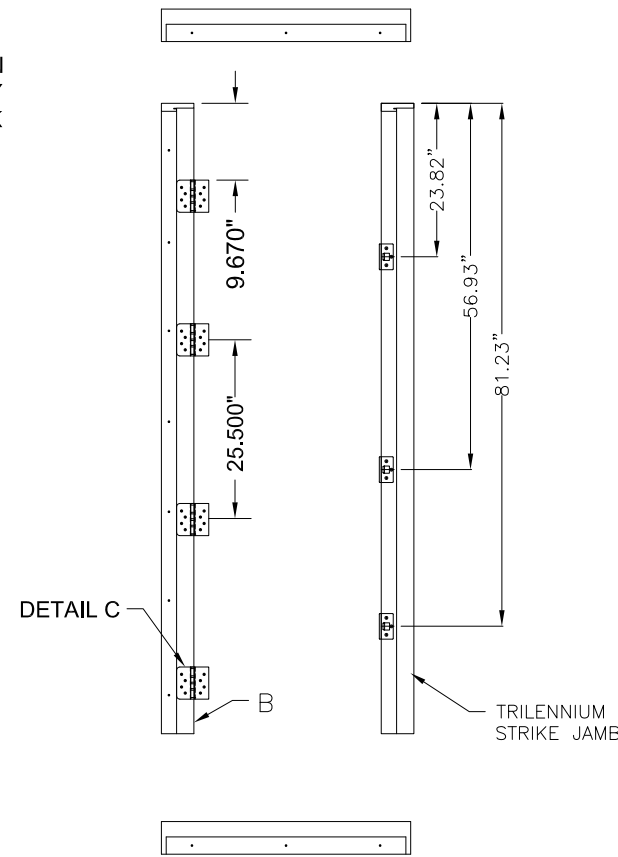

**INSTALLATION NOTES:**

- ONE (1) INSTALLATION ANCHOR IS REQUIRED AT EACH ANCHOR LOCATION SHOWN.
- THE NUMBER OF INSTALLATION ANCHORS DEPICTED IS THE MINIMUM NUMBER OF ANCHORS TO BE USED FOR PRODUCT INSTALLATION. ANCHORS ARE TO MATCH TYPE, SIZE, AND EMBEDMENT OF THOSE SHOWN HEREIN FOR RESPECTIVE SUBSTRATE.
- SHIM AS REQUIRED AT EACH INSTALLATION ANCHOR WITH LOAD BEARING SHIM(S). MAXIMUM ALLOWABLE SHIM SIZE IS 1/4 INCH. SHIM WHERE SPACE OF 1/8 INCH OR GREATER OCCURS. SHIM(S) SHALL BE CONSTRUCTED OF HIGH DENSITY PLASTIC OR BETTER.
- FOR INSTALLATION INTO WOOD FRAMING, USE #10 WOOD SCREWS OF SUFFICIENT LENGTH TO ACHIEVE 1 3/8" MINIMUM EMBEDMENT.
- FOR INSTALLATION THROUGH 1X BUCK TO CONCRETE / MASONRY, OR DIRECTLY INTO CONCRETE / MASONRY, USE 1/4 TAPCON OF SUFFICIENT LENGTH TO ACHIEVE 1 1/4" MINIMUM EMBEDMENT WITH A 2" MINIMUM EDGE DISTANCE.
- ALTERNATE CONCRETE / MASONRY INSTALLATION ANCHORS OF EQUIVALENT PERFORMANCE CHARACTERISTICS CAN BE USED UPON APPROVAL OF ARCHITECT OR ENGINEER OF RECORD FOR THE PROJECT OF INSTALLATION.
- MINIMUM EMBEDMENT AND EDGE DISTANCE EXCLUDE WALL FINISHES (INCLUDING BUT NOT LIMITED TO STUCCO, FOAM, BRICK VENEER, AND SIDING).
- INSTALLATION ANCHOR CAPACITIES FOR PRODUCTS SHOWN HEREIN ARE BASED ON SUBSTRATE MATERIALS WITH THE FOLLOWING PROPERTIES:
  - WOOD - MINIMUM SPECIFIC GRAVITY OF 0.42.
  - CONCRETE - MINIMUM COMPRESSIVE STRENGTH OF 3192 PSI.
  - MASONRY - STRENGTH CONFORMANCE TO ASTM C-90, GRADE N, TYPE 1 (OR GREATER).

SIGNED: 11/10/2021

ENDURA PRODUCTS, INC.  
8817 WEST MARKET STREET  
COLFAX, NC 27235

PLASTPRO GLAZED  
FIBERGLASS DOORS  
ELEVATION AND ANCHOR LAYOUT

DRAWN: RM	DWG NO. NL-0014	REV C
SCALE NTS	DATE 07/30/13	SHEET 8 OF 9

L. ROBERTO LOMAS P.E.  
1432 WOODFORD RD LEWISVILLE, NC 27023  
434-688-0609 rllomas@rlomaspe.com



Luis R. Lomas P.E.  
TX No.: 101889



BILL OF MATERIAL			
ITEM #	DESCRIPTION	QTY.	MATERIAL
1	HEAD / JAMB		
2	OUTSWING BUMP THRESHOLD ZOBL4565		
3	INSWING ADJUSTABLE THRESHOLD ZAQL4565		
4	DOOR STILE - CORE MATERIAL WOOD OR LVL		
5	DOOR TOP RAIL		
6	DOOR BOTTOM RAIL		
7	DOOR LOCK STILE - CORE MATERIAL WOOD OR LVL		
8	DOOR SKIN (MIN. 0.070" THICK)		
9	DOOR SKIN (MIN. 0.140" THICK)		
10	REINFORCEMENT WOOD FOR LOCKS		
11	COMPRESSION WEATHERSTRIP-PE-650 QLON		
12	VINYL DOOR BOTTOM SWEEP-DBKAC		
13	CORNER PAD		
14	4" X 4" HINGE BUTT		
15	CONTINUOUS LATCH AND HINGE STILE REINFORCEMENT		
16	POLYURETHANE FOAM BY PLASTPRO		
17	EXTRUDED ALUMINUM ASTRAGAL BY ENDURA-6063T-6		
18	WOOD ASTRAGAL BY ENDURA		
19	LATCH STRIKE PLATE		
20	DEAD BOLT STRIKE PLATE		
21	KWIKSET KNOB (SIGNATURE SERIES)		
22	KWIKSET DEADBOLT (SIGNATURE SERIES 980 / 985)		
23	LATCH STRIKE PLATE 3500 / 3020		
24	DEADBOLT PLATE		
25	ASTRAGAL STRIKE PLATE		
26	TRILENNIUM 3500 / 3020 LOCK		
27	TRILENNIUM 3070 MULTIPOINT LOCK		
28	#10 X 3/4" PFH WOOD SCREW (HINGE TO FRAME)		
29	#10 X 2 - 1/2" PFH WOOD SCREW		
30	#10 X 1" PFH WOOD SCREW		
31	ODL GLAZING INSERT-ALUMINUM LIGHT FRAME		
32	RSL GLAZING INSERT-PVC FRAME		
33	ECLIPSE INTERIOR LOCK TRIM		
34	INSWING THRESHOLD ZAQLAA4565		
35	INSWING THRESHOLD ZAIL4565		
36	INSWING THRESHOLD ZAILAA4565		
37	TRILENNIUM 3000 MULTIPOINT LOCK		

REVISIONS			
REV	DESCRIPTION	DATE	APPROVED
C	REVISED PER NEW CODE	11/10/2021	R.L.

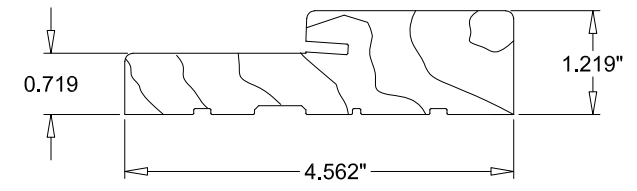

1 FRAME HEAD / JAMB BY ENDURA (PINE SG = 0.37)

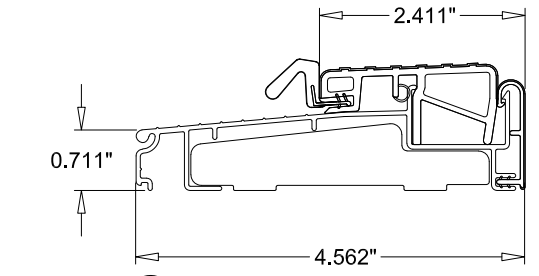

2 OUTSWING THRESHOLD ALUMINUM / WOOD BY ENDURA ZOBL4565

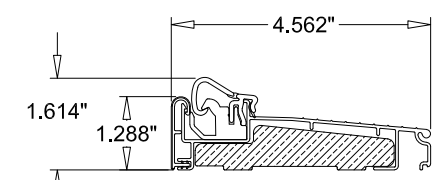

3 INSWING THRESHOLD ALUMINUM / WOOD BY ENDURA ZAQL4565

GENERAL PLASTICS NOTES:

- POLYURETHANE CORE FLAME SPREAD INDEX OF 50 AND SMOKE DEVELOPED INDEX OF 60 PER ASTM E84.
- PLASTICS TESTING OF FIBERLASS FACING:

Test Description	Test Method	Test Result
SELF IGNITION TEMP	ASTM D1929	Passed (>650 °F)
RATE OF BURNING	ASTM D635	Passed (C-1:<1.0 in/min)
SMOKE DENSITY	ASTM D2843	Passed (<75%)
TENSILE STRENGTH*	ASTM D638	Passed (<10%)

3. PVC PLASTICS TESTING OF RSL LITE FRAME MATERIAL:

Test Description	Test Method	Test Result
SELF IGNITION TEMP	ASTM D1929	Passed (>650 °F)
RATE OF BURNING	ASTM D635	Passed (C-1:<1.0 in/min)
SMOKE DENSITY	ASTM D2843	Passed (<75%)
FLEXURAL STRENGTH*	ASTM D790	BEFORE = 3366 PSI AFTER = *3058 PSI

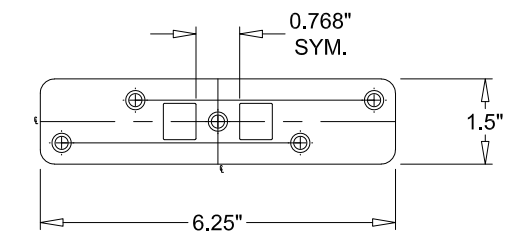

23 3500 / 3020 STRIKE PLATE STEEL

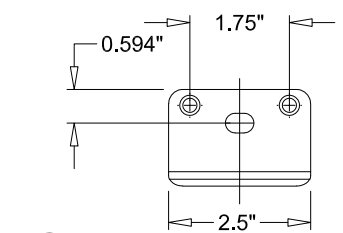

25 ASTRAGAL STRIKE PLATE STEEL

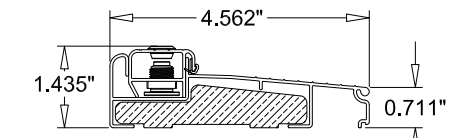

36 INSWING THRESHOLD ALUMINUM / WOOD BY ENDURA ZAILAA4565

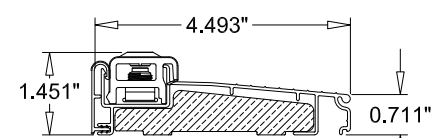

35 INSWING THRESHOLD ALUMINUM / WOOD BY ENDURA ZAIL4565

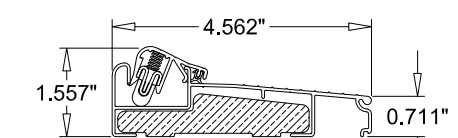

34 INSWING THRESHOLD ALUMINUM / WOOD BY ENDURA ZAQLAA4565

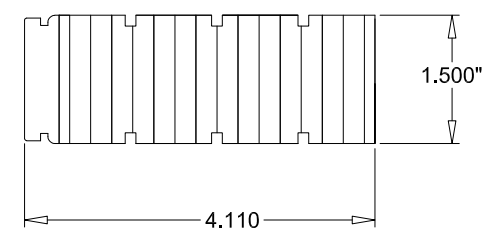

7 LOCK STILE (LVL)

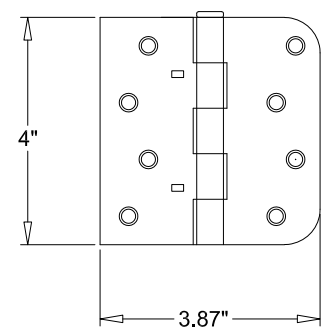

14 4" X 4" HINGE 0.097" THICK STEEL

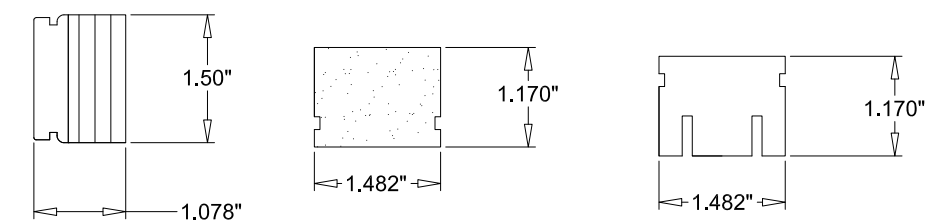

4 HINGE STILE (LVL)      5 DOOR TOP RAIL (PINE SG = 0.42)      6 DOOR BOTTOM RAIL (PINE SG = 0.42)

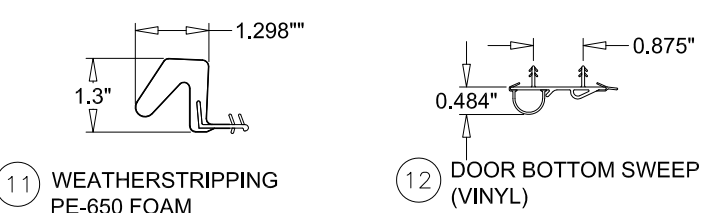

11 WEATHERSTRIPPING PE-650 FOAM      12 DOOR BOTTOM SWEEP (VINYL)

SIGNED: 11/10/2021

ENDURA PRODUCTS, INC.  
8817 WEST MARKET STREET  
COLFAX, NC 27235

PLASTPRO GLAZED  
FIBERGLASS DOORS  
BILL OF MATERIALS AND COMPONENTS

DRAWN: RM	DWG NO. NL-0014	REV C
SCALE NTS	DATE 07/30/13	SHEET 9 OF 9

L. ROBERTO LOMAS P.E.  
1432 WOODFORD RD LEWISVILLE, NC 27023  
434-688-0609 rllomas@rlomaspe.com



Luis R. Lomas P.E.  
TX No.: 101889