

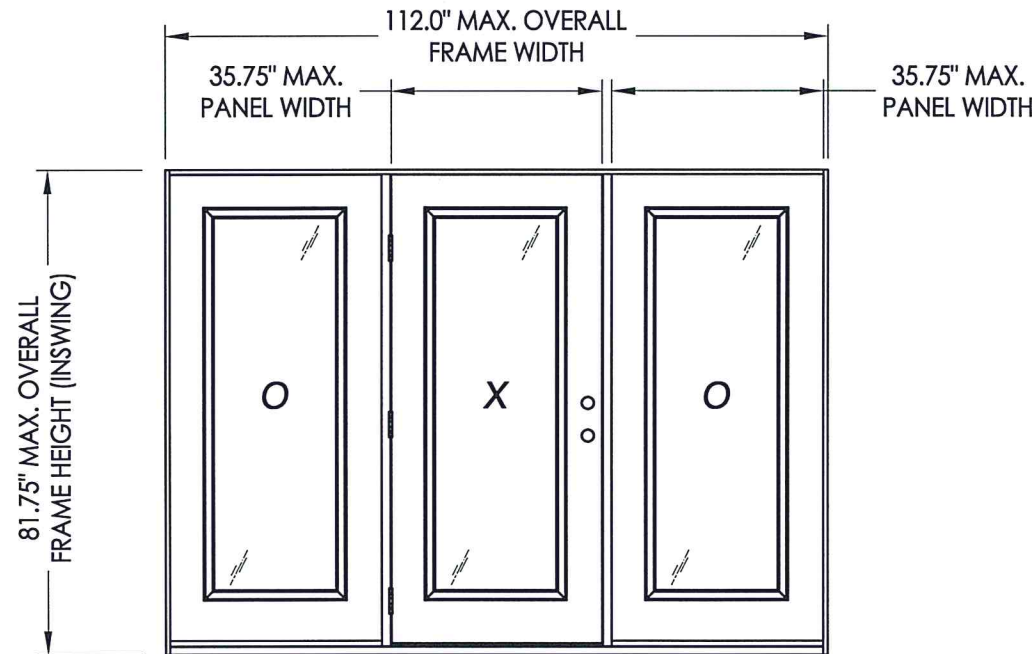

215 EAST ROOSEVELT AVE.
ZEELAND, MI 49464

FIBERGLASS ENTRY DOOR IN SWING "IMPACT"

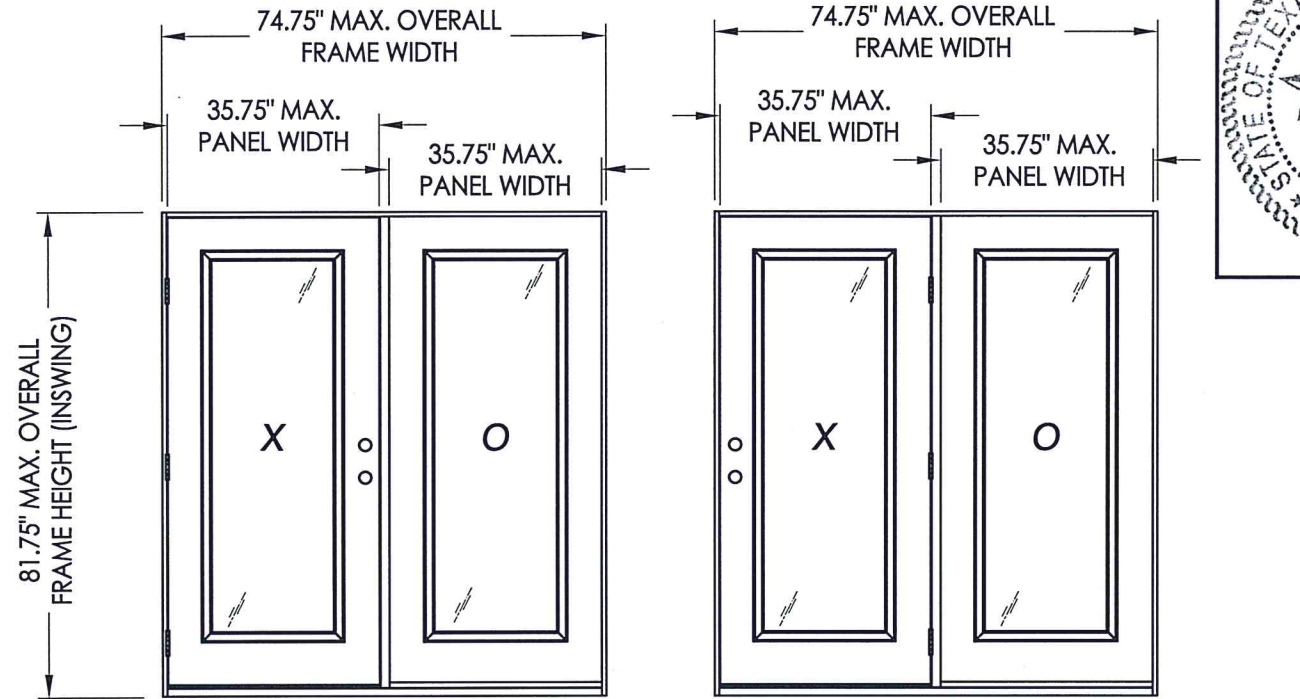

CONTINUOUS HEAD & SILL

CONFIGURATION	MAX. FRAME DIMENSION	DESIGN PRESSURE (PSF) INSWING	
		POSITIVE	NEGATIVE
OX/XO	74.75" x 81.75"	+45.0	-50.0
OXO	112.0" x 81.75"	+45.0	-50.0

EVALUATED FOR USE IN THE STATE OF TEXAS

TDI DR-692

The Fiberglass Door system described herein complies with the 2018 International Residential Code (IRC), Sections R301 & R609 and the 2018 International Building Code (IBC), Sections 1404.13, 1609, 1709.5, 2403 and 2404 subject to the following conditions:

1. Anchors shall be as listed and spaced as shown in the details. Anchor embedment to base material shall be beyond wall dressing or stucco.
2. This system has been tested and evaluated as a large missile impact protective system for installation in areas that require wind borne debris protection. This product meets missile level "D" as defined in ASTM E 1996.
3. Allowable design pressure requirements must be equal to or less than the design pressure rating shown in the design pressure chart, sheet 1 of this drawing.
4. Conditions not covered by this drawing are subject to further engineering analysis.

TABLE OF CONTENTS

SHEET #	DESCRIPTION
1	Typical elevations, design pressures & general notes
2	Door/Sidelite panel details
3	Lite frame and glazing details
4	Elevations & hardware table
5	Horizontal cross sections
6	Vertical cross sections
7	Vertical cross sections
8	Frame anchoring
9	Bill of materials & components

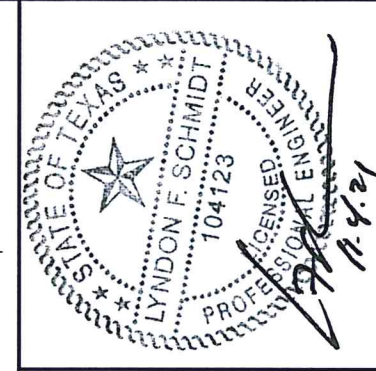

Documents Prepared By: Lyndon F. Schmidt, P.E.
TEXAS P.E. #104123

RW BUILDING CONSULTANTS, INC.
P.O. Box 230 Valrico FL 33595
Phone No.: 813.659.9197

TEXAS BOARD OF PROFESSIONAL ENGINEERS
CERTIFICATE OF REGISTRATION # F-11852

PRODUCT: FIBERGLASS DOOR

PART OR ASSEMBLY: TYPICAL ELEVATION, DESIGN PRESSURES & GENERAL NOTES

NO.	DATE	REVISIONS
3	10/26/21	UPDATE TO 2018 IRC/IRC
2	5/31/18	ADD FLAT FRAME LITE PROFILE
1	12/14/15	ADD H.S. GLAZING OPTION

DATE: 6/13/13

SCALE: N.T.S.

DWG. BY: JK

CHK. BY: LFS

DRAWING NO.: TX-4374

SHEET 1 OF 9

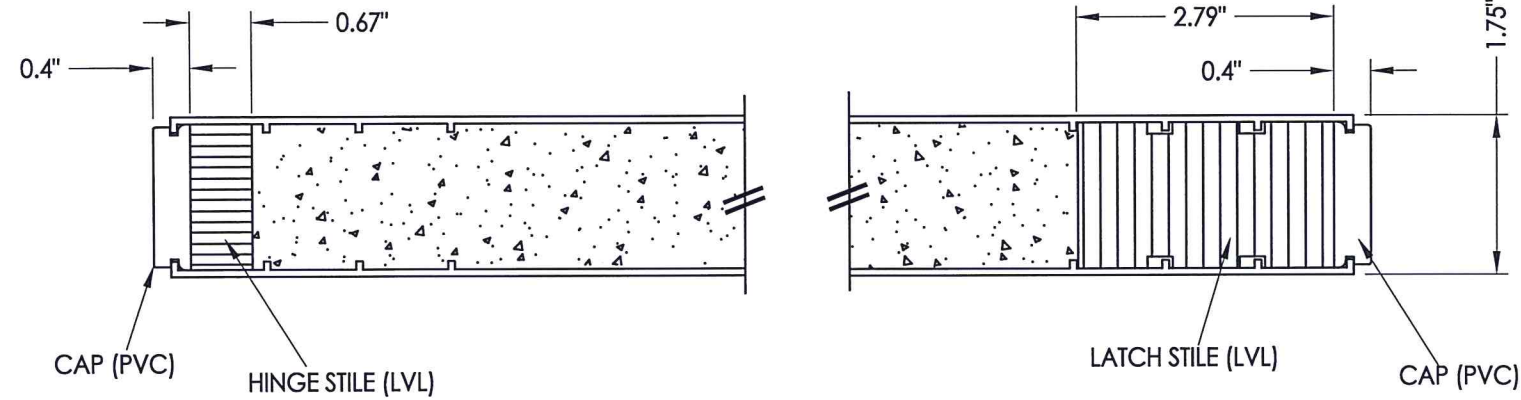

1
2 HORIZONTAL CROSS SECTION

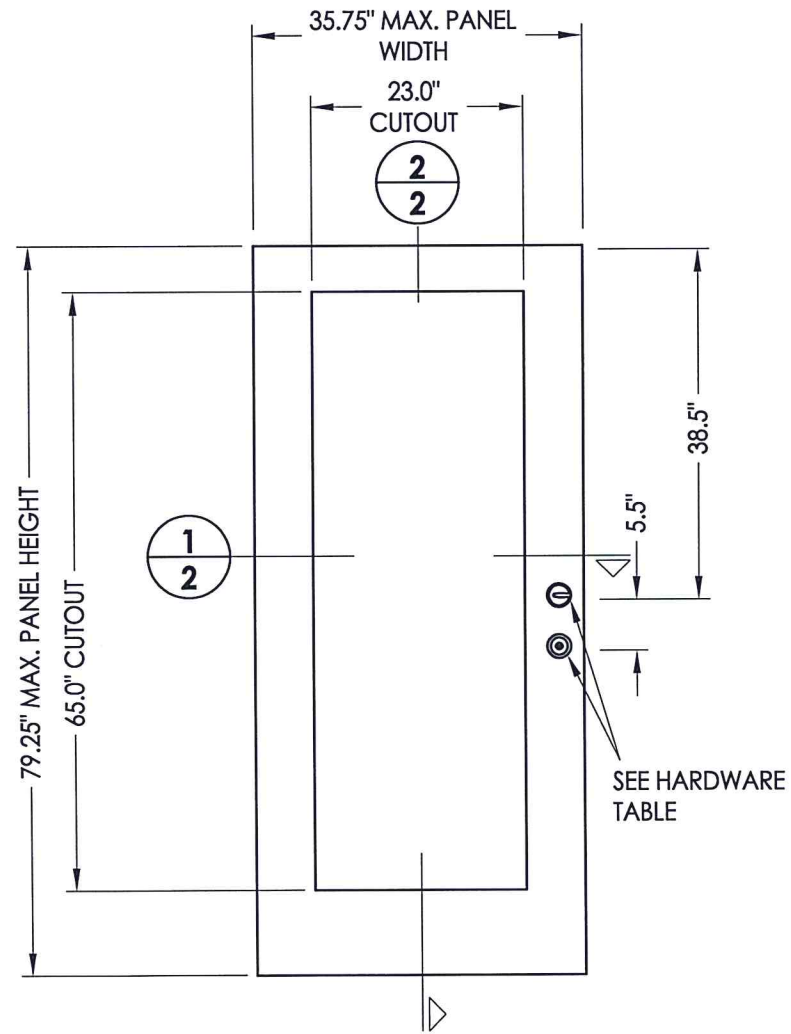

- 40** DOOR PANEL
Plastpro
- 50** SIDELITE PANEL
Fiberglass (Plastpro)

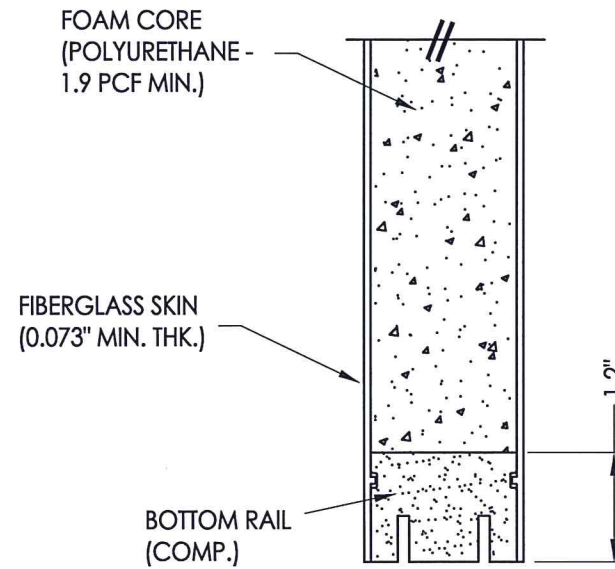
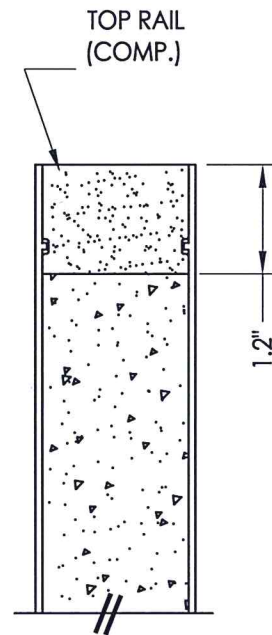

2
2 VERTICAL CROSS SECTION

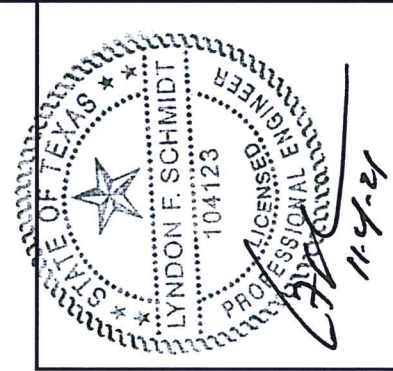

Documents Prepared By: Lyndon F. Schmidt, P.E.
TEXAS P.E. #104123

RW BUILDING CONSULTANTS, INC.
P.O. Box 230 Valrico FL 33595
Phone No.: 813.659.9197

TEXAS BOARD OF PROFESSIONAL ENGINEERS
CERTIFICATE OF REGISTRATION # F-11852

PRODUCT: FIBERGLASS DOOR
PART OR ASSEMBLY: DOOR/SIDELITE PANEL DETAILS

NO.	DATE	REVISIONS
3	10/26/21	UPDATE TO 2018 IBC/IRC
2	5/31/18	ADD FLAT FRAME LITE PROFILE
1	12/14/15	ADD H.S. GLAZING OPTION

DATE: 6/13/13
SCALE: N.T.S.
DWG. BY: JK
CHK. BY: LFS
DRAWING NO.: TX-4374
SHEET 2 OF 9

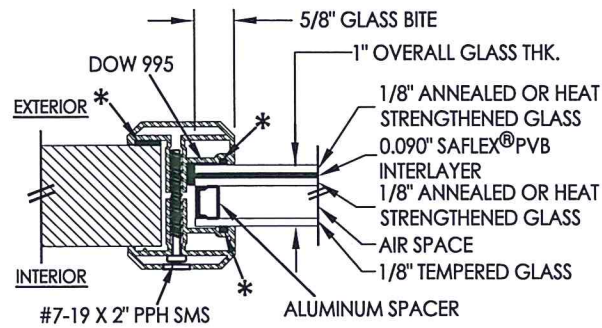

G1 GLAZING DETAIL
Flat Frame Profile

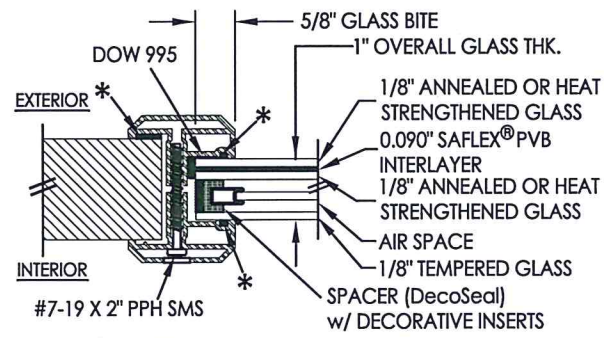

G3 GLAZING DETAIL
Flat Frame Profile

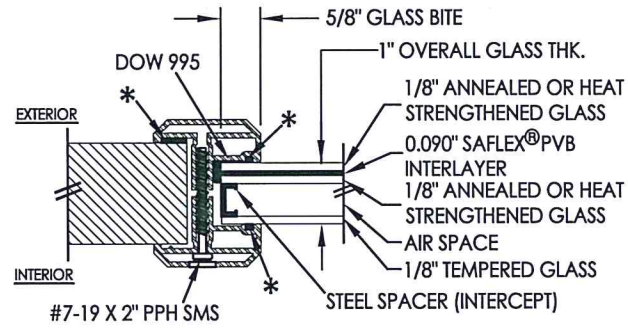

G2 GLAZING DETAIL
Flat Frame Profile

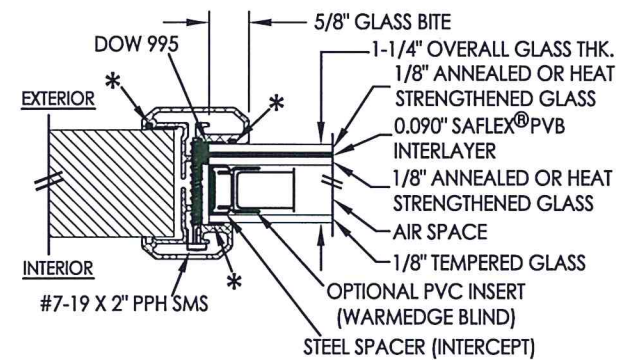

G4 GLAZING DETAIL
Flat Frame Profile
w/ Blinds Between Glass

* NON-STRUCTURAL
BACKBEDDING
(READI-SEAL)

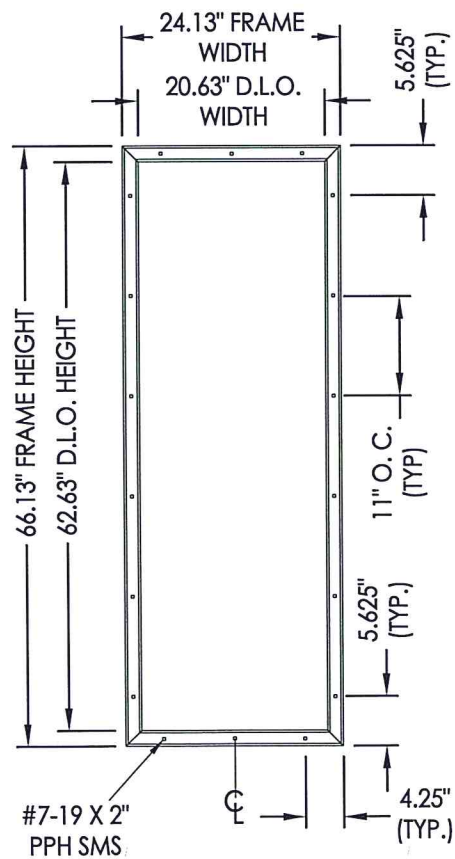

ODL LITE FRAME
"Flat Frame" Aluminum

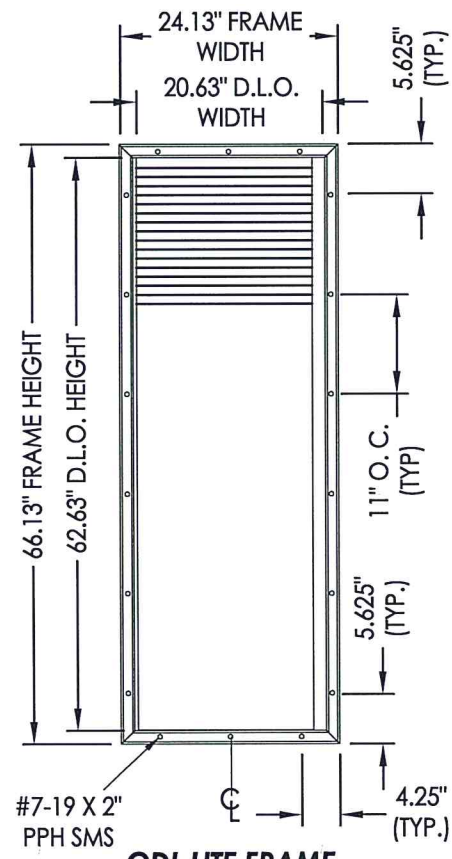

ODL LITE FRAME
"Flat Frame" Aluminum
w/ Blinds Between Glass

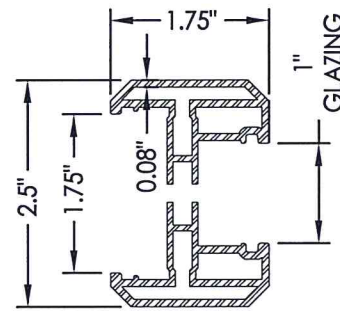

ODL LITE FLAT FRAME
1" GLAZING

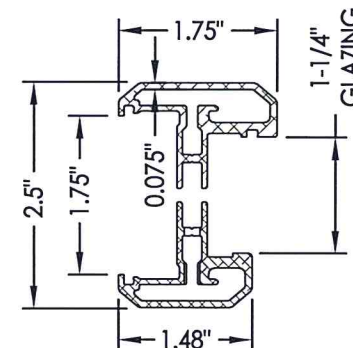

ODL LITE FLAT FRAME
1-1/4" GLAZING



Documents Prepared By: Lyndon F. Schmidt, P.E.
TEXAS P.E. #104123

RW BUILDING CONSULTANTS, INC.
P.O. Box 230 Valrico FL 33595
Phone No.: 813.659.9197

TEXAS BOARD OF PROFESSIONAL ENGINEERS
CERTIFICATE OF REGISTRATION # F-11852

PRODUCT: FIBERGLASS DOOR
PART OR ASSEMBLY: LITE FRAME & GLAZING DETAILS

NO.	DATE	BY	REVISIONS
3	10/26/21	LFS	UPDATE TO 2018 IBC/IRC
2	5/31/18	LFS	ADD FLAT FRAME LITE PROFILE
1	12/14/15	JK	ADD H.S. GLAZING OPTION

DATE: 6/13/13
SCALE: N.T.S.
DWG. BY: JK
CHK. BY: LFS
DRAWING NO.: TX-4374
SHEET 3 of 9

HARDWARE TABLE		
MANUFACTURER	MODEL	
KWIKSET	KNOB: DEADBOLT:	SIGNATURE SERIES SIGNATURE SERIES (980)
SCHLAGE	KNOB: DEADBOLT:	"F" SERIES (F60) "B" SERIES (B60/62)
PAMEX*	KNOB: DEADBOLT:	"FT" SERIES "FD7" SERIES

* MAX. DESIGN PRESSURE FOR PAMEX LOCK
INSWING = +40/-50 PSF

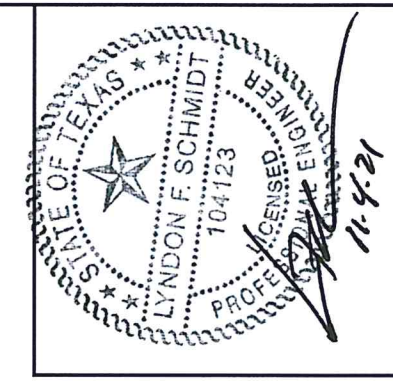

Documents Prepared By: Lyndon F. Schmidt, P.E.
TEXAS P.E. #104123

RW BUILDING CONSULTANTS, INC.
P.O. Box 230 Vairco FL 33595
Phone No.: 813.659.9197

TEXAS BOARD OF PROFESSIONAL ENGINEERS
CERTIFICATE OF REGISTRATION # F-11852

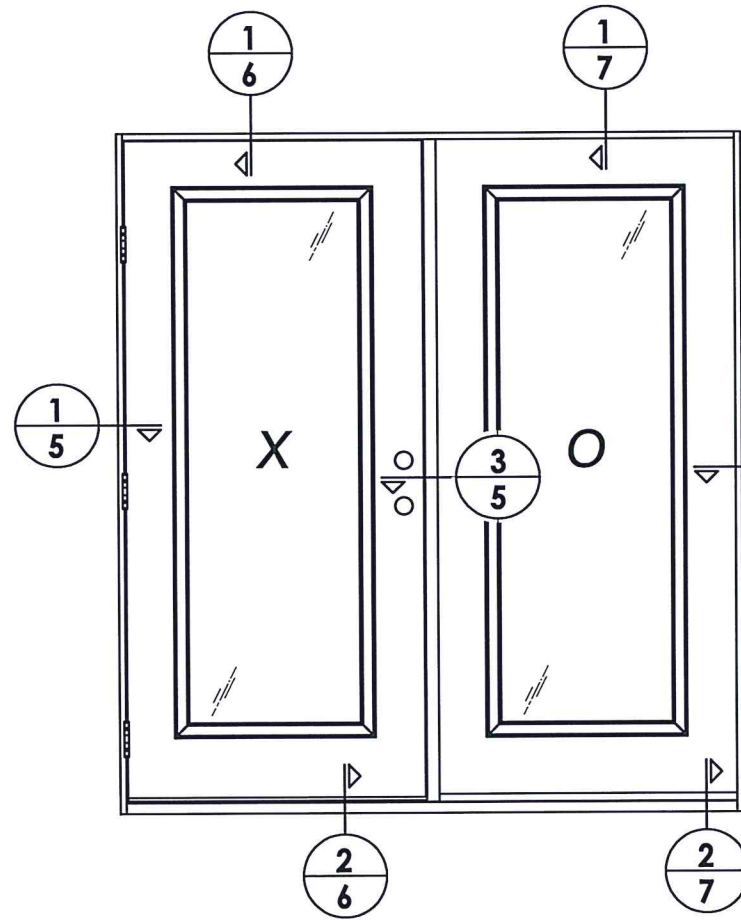

ELEVATION (XO - OX)

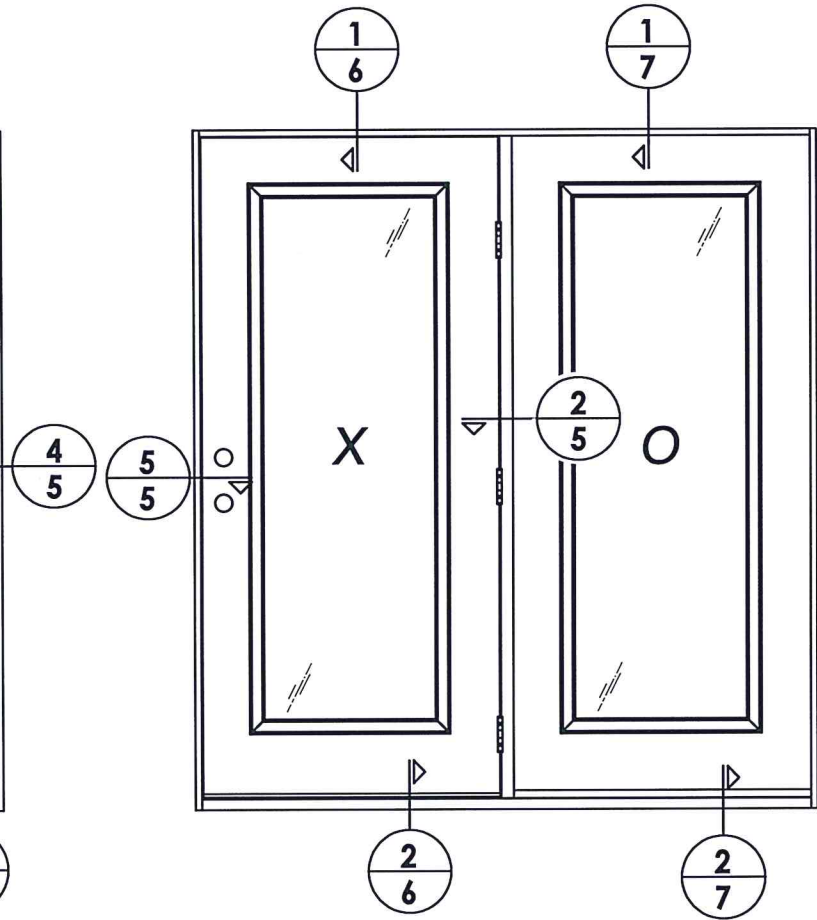

ELEVATION (XO - OX)
center hinge

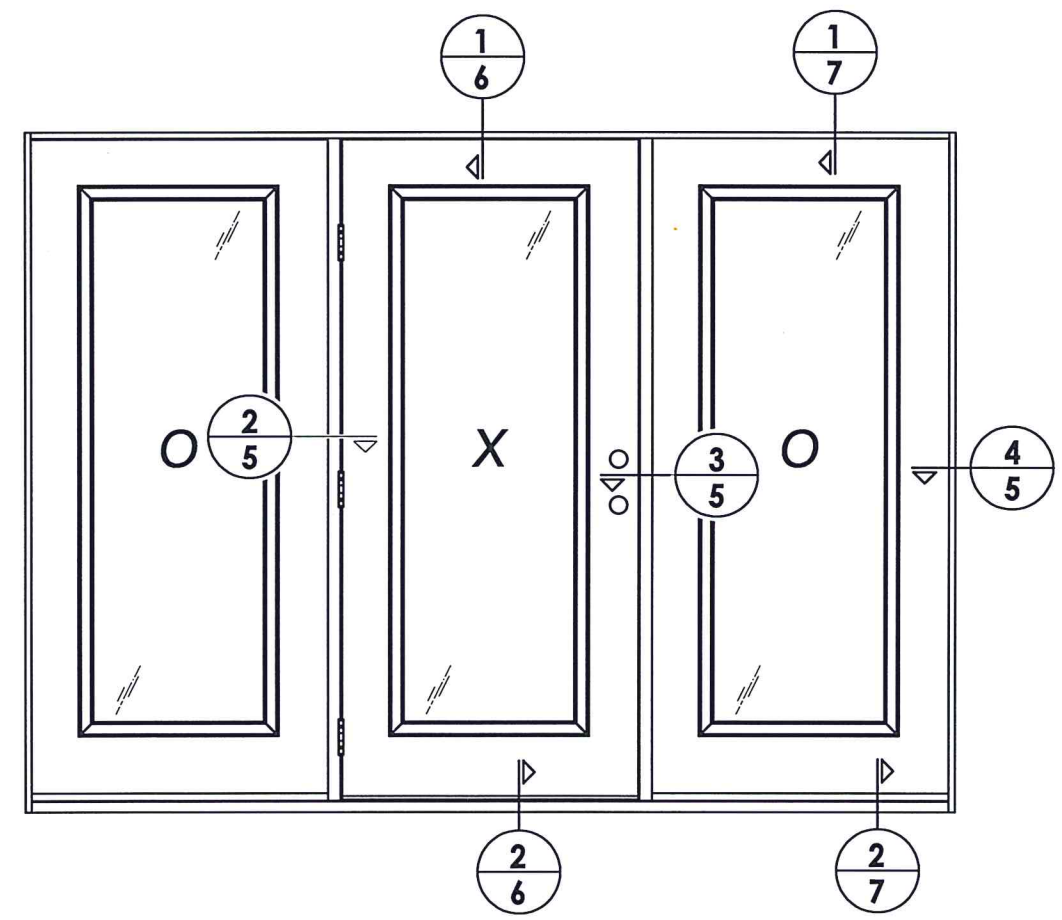

ELEVATION (OXO)

PRODUCT: FIBERGLASS DOOR	
PART OR ASSEMBLY: ELEVATIONS & HARDWARE TABLE	
NO.	DATE
3	10/26/21
2	5/31/18
1	12/14/15
REVISIONS	
LFS	DATE
LFS	DATE
JK	DATE
BY	DATE
DATE: 6/13/13	
SCALE: N.T.S.	
DWG. BY: JK	
CHK. BY: LFS	
DRAWING NO.: TX-4374	
SHEET 4 OF 9	

Z:\Clients\ODL, Inc. PERMANENT\B - Texas Dept of Ins\TDI - 692\Drawings\TX-4374-75.dwg

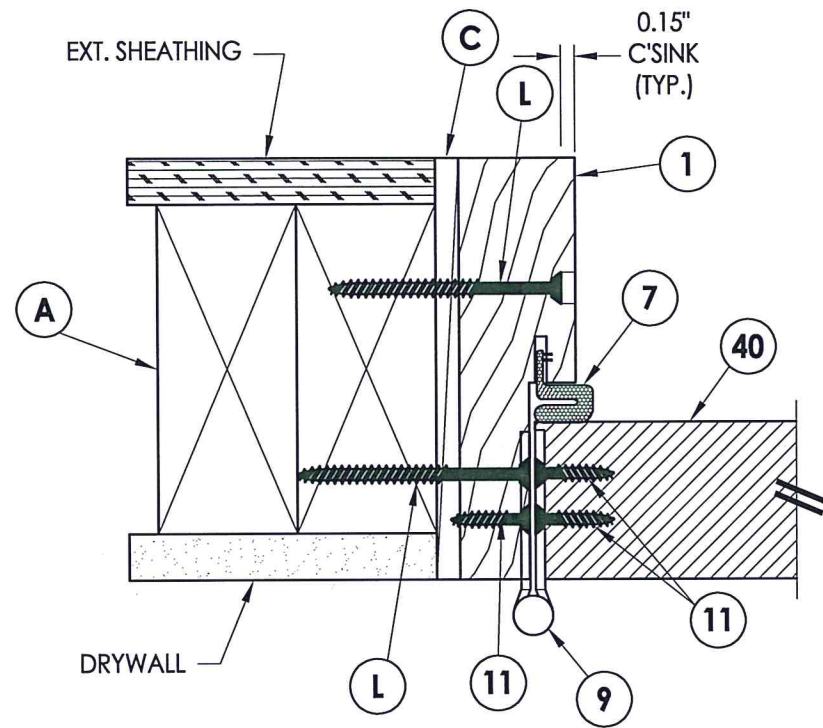

1
5 HORIZONTAL CROSS SECTION

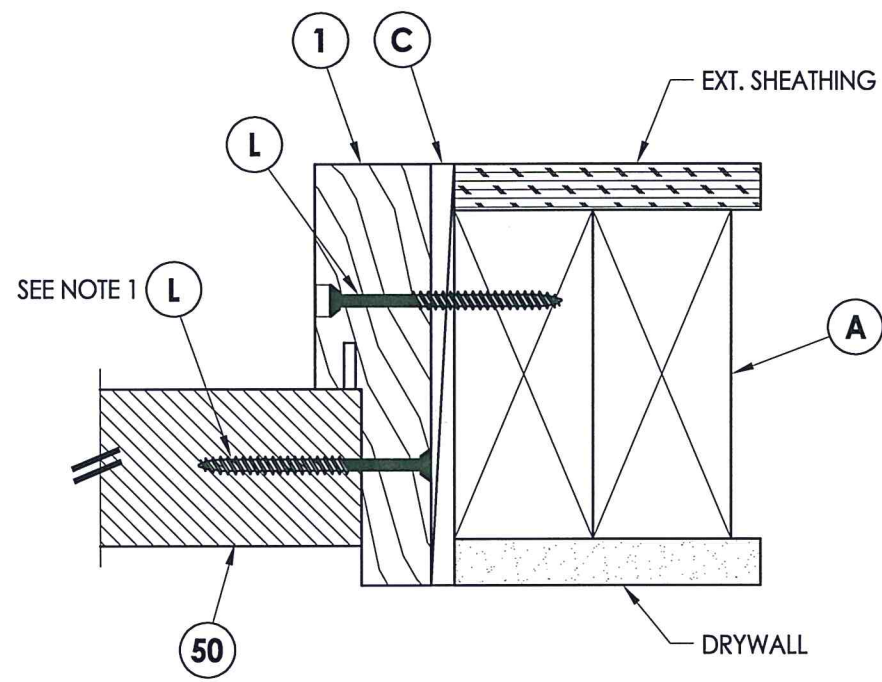

4
5 HORIZONTAL CROSS SECTION

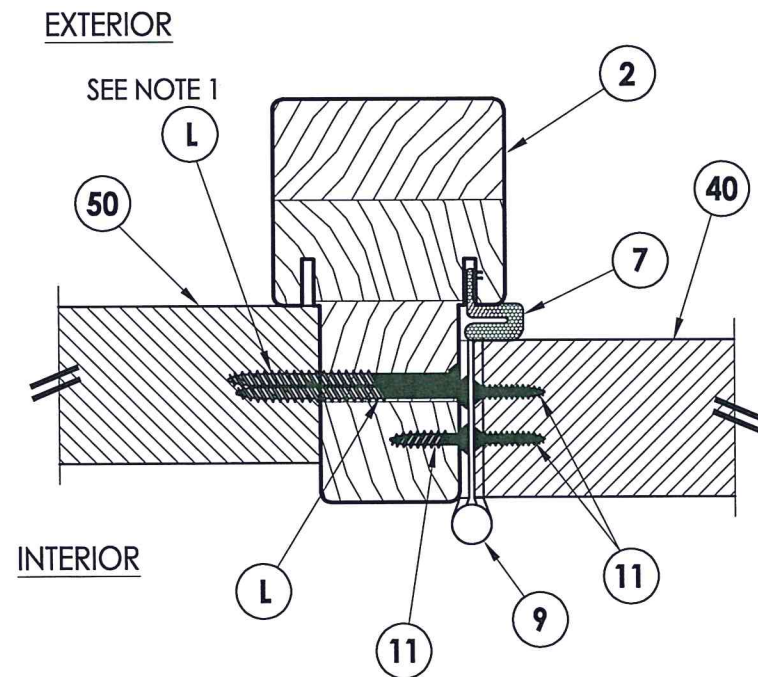

2
5 HORIZONTAL CROSS SECTION

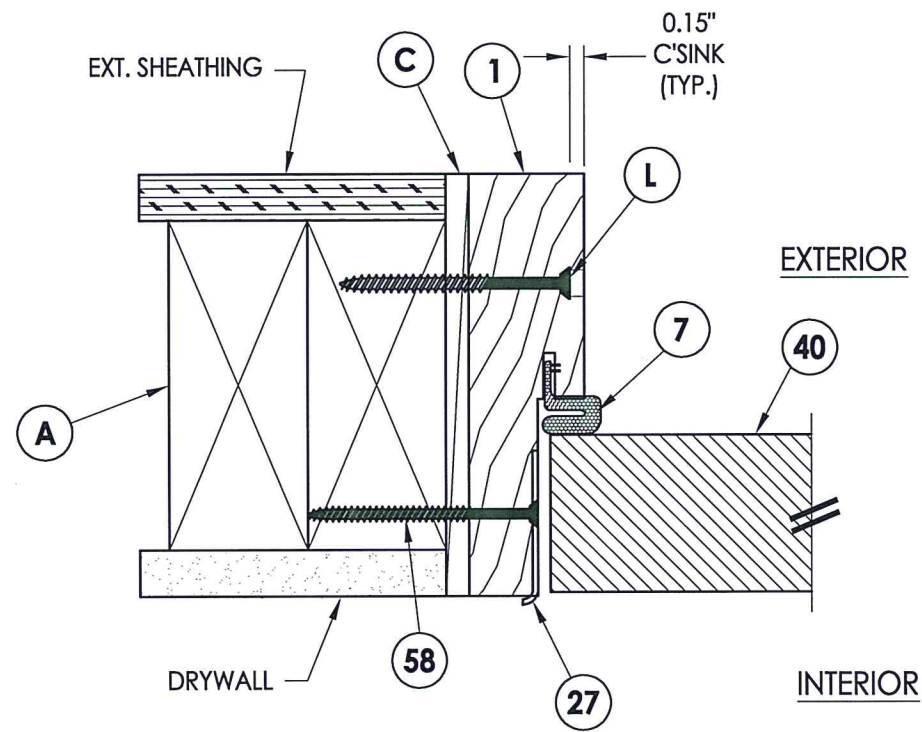

5
5 HORIZONTAL CROSS SECTION

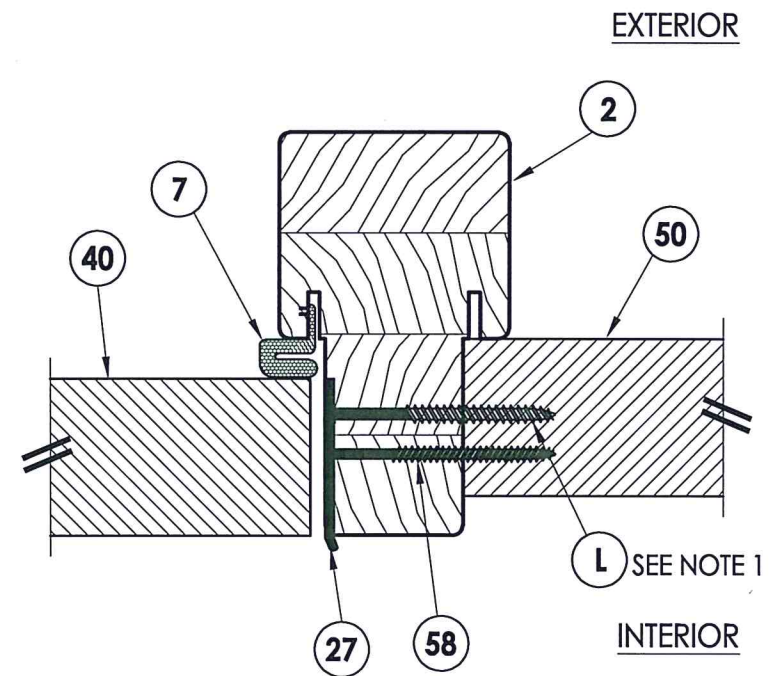

3
5 HORIZONTAL CROSS SECTION

NOTE:
1. Sidelite panel screws located 6" from each end and equally spaced (4 screws total)

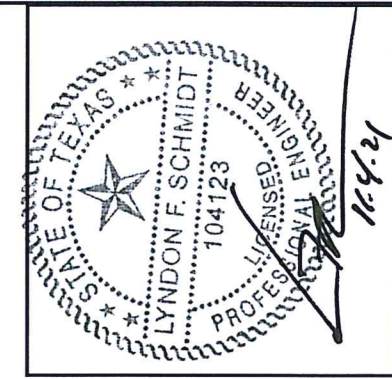

Documents Prepared By: Lyndon F. Schmidt, P.E.
TEXAS P.E. #104123

RW BUILDING CONSULTANTS, INC.
P.O. Box 230 Valrico FL 33595
Phone No.: 813.659.9197
TEXAS BOARD OF PROFESSIONAL ENGINEERS
CERTIFICATE OF REGISTRATION # F-11852

PRODUCT: FIBERGLASS DOOR
PART OR ASSEMBLY: HORIZONTAL CROSS SECTIONS

NO.	DATE	REVISIONS
3	10/26/21	UPDATE TO 2018 IBC/IRC
2	5/31/18	ADD FLAT FRAME LITE PROFILE
1	12/14/15	ADD H.S. GLAZING OPTION

DATE: 6/13/13
SCALE: N.T.S.
DWG. BY: JK
CHK. BY: LFS
DRAWING NO.: TX-4374
SHEET 5 OF 9

© 2013 R.W. BUILDING CONSULTANTS INC.

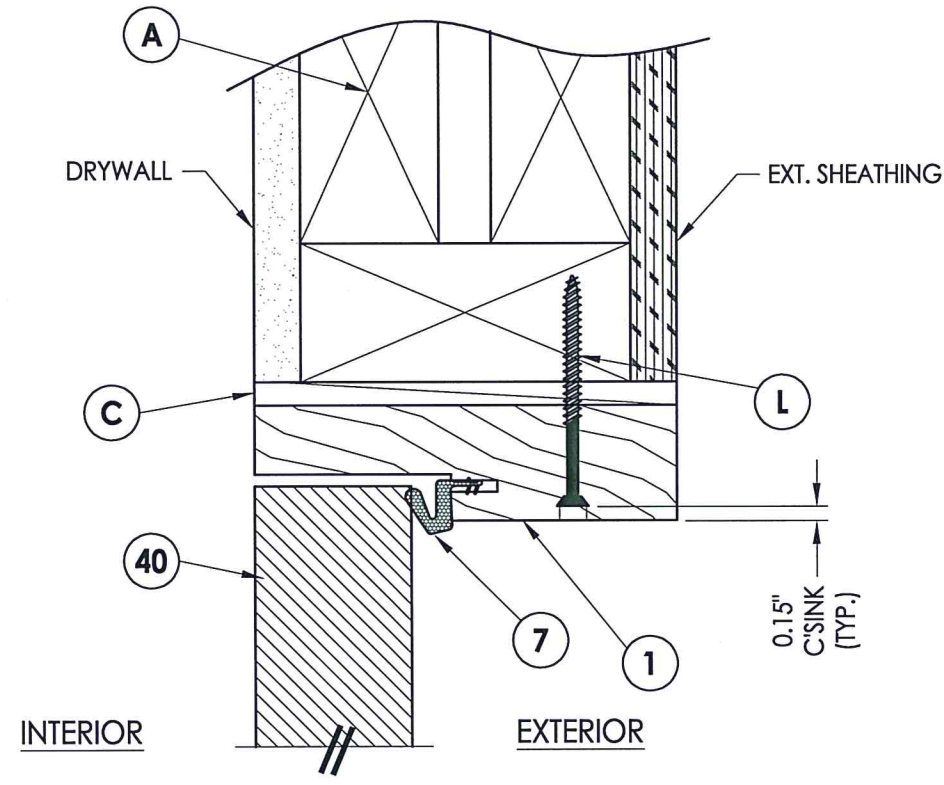

1
6 VERTICAL CROSS SECTION

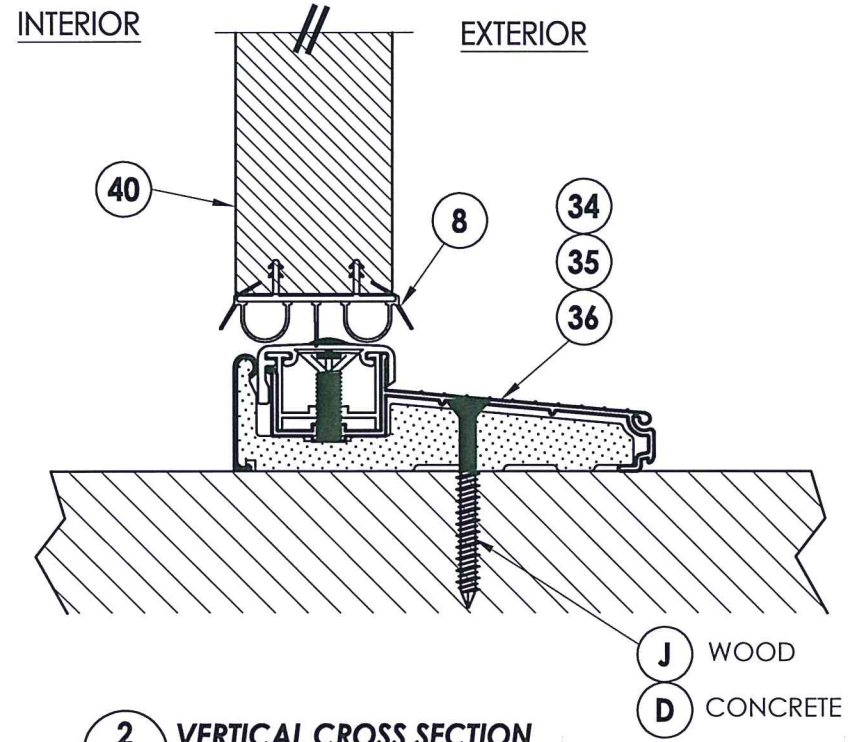

2
6 VERTICAL CROSS SECTION

J WOOD
D CONCRETE

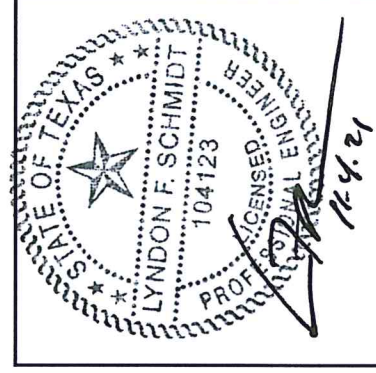

Documents Prepared By: Lyndon F. Schmidt, P.E.
TEXAS P.E. #104123

RW BUILDING CONSULTANTS, INC.
P.O. Box 230 Vairico FL, 33595
Phone No.: 813.659.9197
TEXAS BOARD OF PROFESSIONAL ENGINEERS
CERTIFICATE OF REGISTRATION # F-11852

PRODUCT: FIBERGLASS DOOR
PART OR ASSEMBLY: VERTICAL CROSS SECTIONS

NO.	DATE	REVISIONS	BY
3	10/26/21	UPDATE TO 2018 IBC/IRC	LFS
2	5/31/18	ADD FLAT FRAME LITE PROFILE	LFS
1	12/14/15	ADD H.S. GLAZING OPTION	JK

DATE: 6/13/13

SCALE: N.T.S.

DWG. BY: JK

CHK. BY: LFS

DRAWING NO.: TX-4374

SHEET 6 OF 9

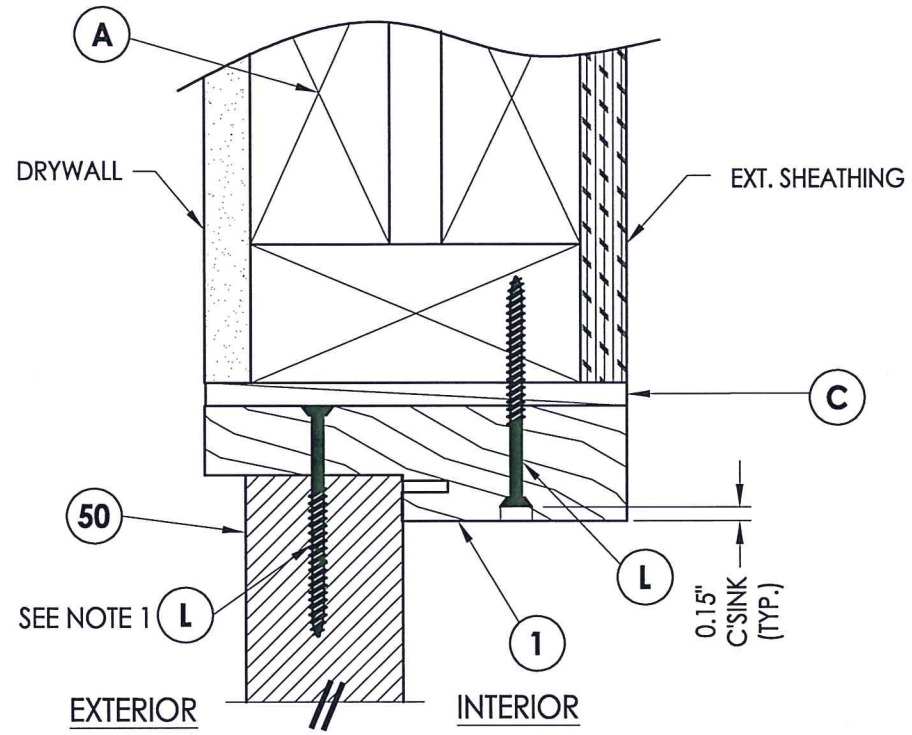

1
7 VERTICAL CROSS SECTION

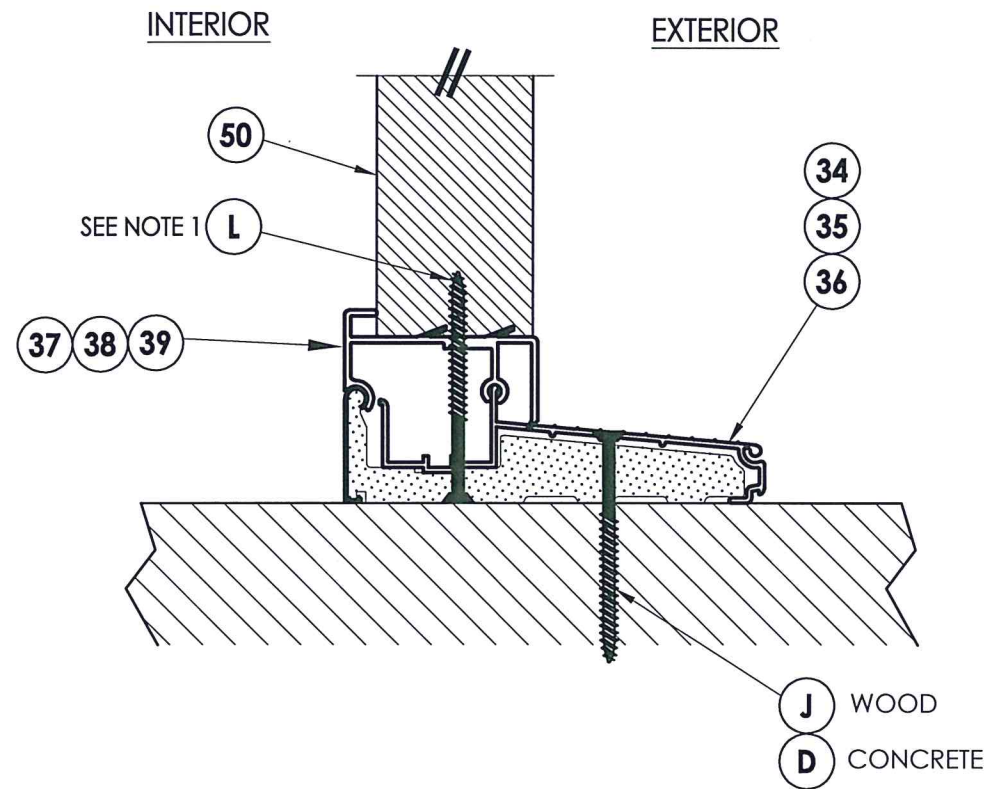

2
7 VERTICAL CROSS SECTION

NOTE:
1. Sidelite panel screws located 3" from each end (2 Total). Not required for Sidelites less than 14" in width.

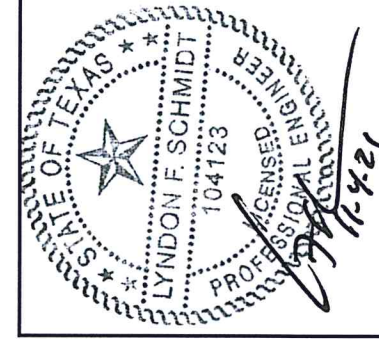

Documents Prepared By: Lyndon F. Schmidt, P.E.
TEXAS P.E. #104123

RW BUILDING CONSULTANTS, INC.
P.O. Box 230 Valrico FL, 33595
Phone No.: 813.659.9197
TEXAS BOARD OF PROFESSIONAL ENGINEERS
CERTIFICATE OF REGISTRATION # F-11852

PRODUCT:		FIBERGLASS DOOR	
PART OR ASSEMBLY:		VERTICAL CROSS SECTIONS	
NO.	DATE	BY	REVISIONS
3	10/26/21	LFS	UPDATE TO 2018 IBC/IRC
2	5/31/18	LFS	ADD FLAT FRAME LITE PROFILE
1	12/14/15	JK	ADD H.S. GLAZING OPTION
DATE: 6/13/13			
SCALE: N.T.S.			
DWG. BY: JK			
CHK. BY: LFS			
DRAWING NO.: TX-4374			
SHEET 7 of 9			

Z:\Clients\ODL, Inc. PERMANENT\B - Texas Dept of Ins\TDL - 692\Drawings\TX-4374-75.dwg

2X FRAMING TO BE DESIGNED BY THE ENGINEER OR ARCHITECT OF RECORD BASED ON WIND LOADS AND THE CLADDING BEING USED (TYP.).

SEE INTEGRAL MULLION ATTACHMENT DETAIL (TYP. EACH END OF EACH MULLION)

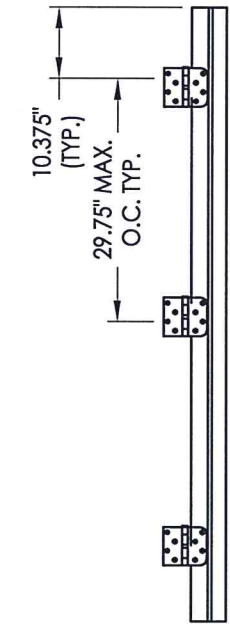
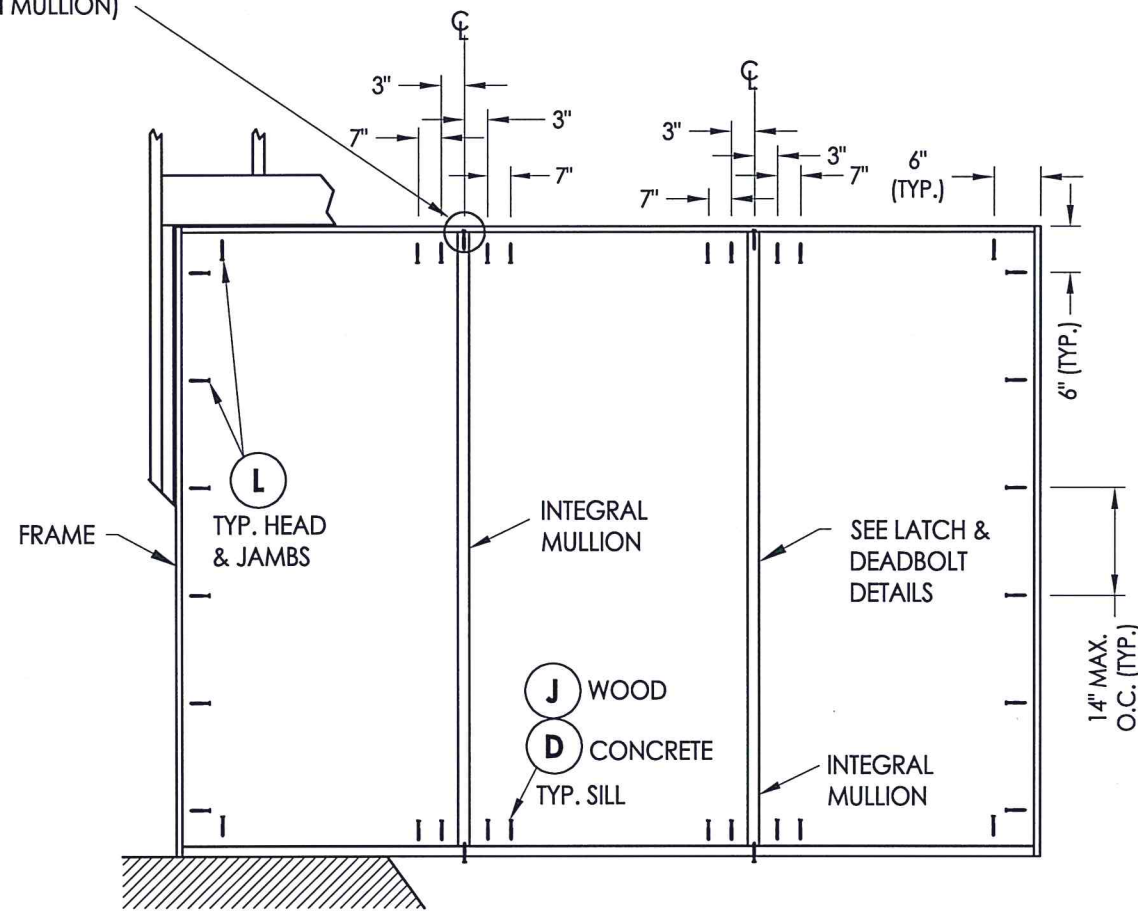
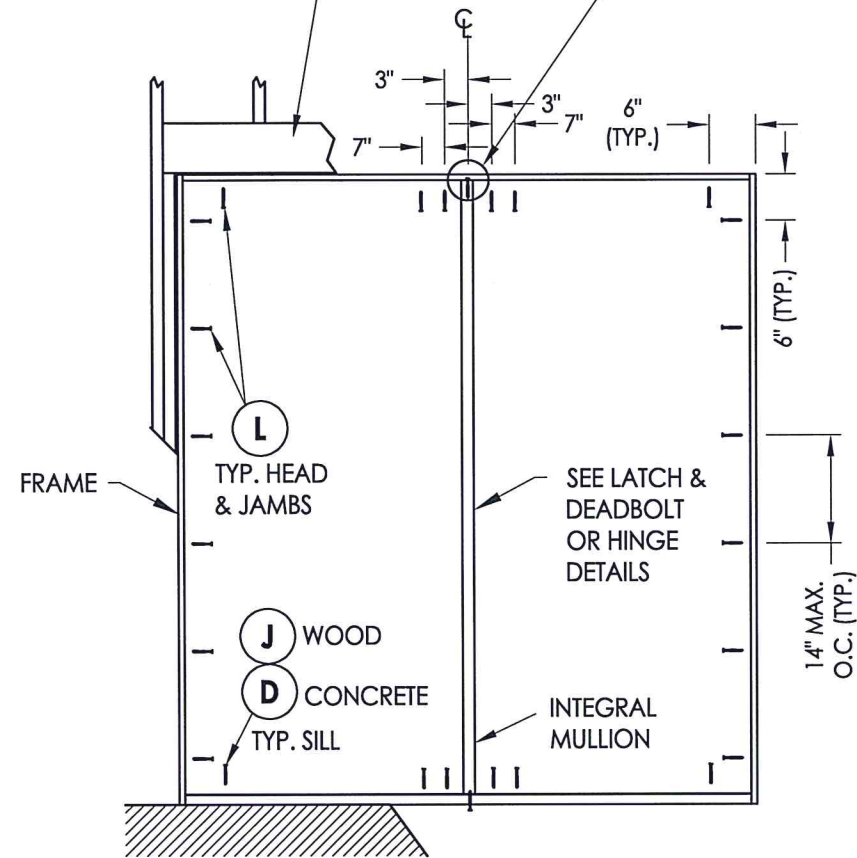

HINGE LOCATIONS

FLOOR SUBSTRATE MATERIAL (TYP.)
 CONCRETE (MIN. 3000 PSI)
 WOOD (G >= 0.42)

FRAME ANCHORING
OX/XO

FRAME ANCHORING
OXO

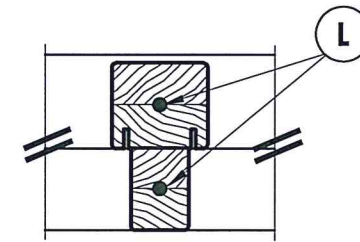

INTEGRAL MULLION ATTACHMENT DETAIL

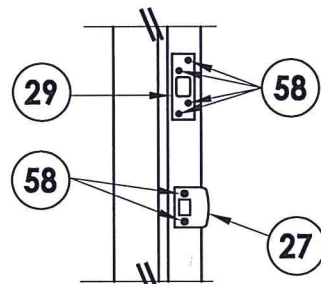

LATCH AND DEADBOLT DETAIL
Kwikset

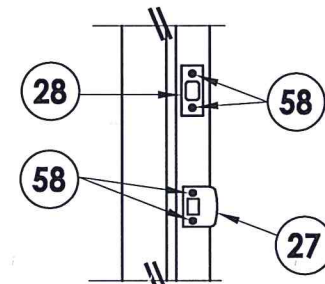

LATCH AND DEADBOLT DETAIL
Schlage / Pamex

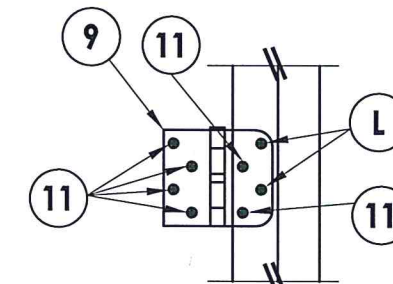

HINGE DETAIL
Inswing

CONCRETE ANCHOR NOTES:

- Concrete anchor locations at the corners may be adjusted to maintain the min. edge distance to mortar joints.
- Concrete anchor locations noted as "MAX. ON CENTER" must be adjusted to maintain the min. edge distance to mortar joints, additional concrete anchors may be required to ensure the "MAX. ON CENTER" dimension are not exceeded.
- Concrete anchor table:

ANCHOR TYPE	ANCHOR SIZE	MIN. EMBEDMENT	MIN. CLEARANCE TO MASONRY EDGE	MIN. CLEARANCE TO ADJACENT ANCHOR
ITW TAPCON®	1/4"	1-3/4"	1-1/2"	4"
DeWALT ULTRACON®	1/4"	1-3/4"	1"	3"

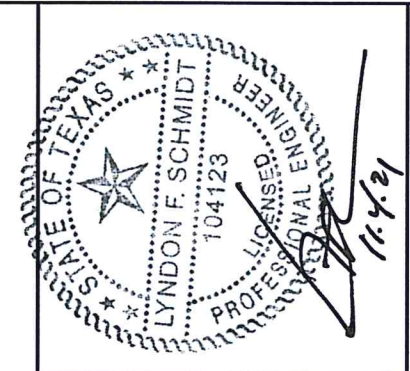

Documents Prepared By: Lyndon F. Schmidt, P.E.
 TEXAS P.E. #104123

RW BUILDING CONSULTANTS, INC.
 P.O. Box 230 Valrico FL 33595
 Phone No.: 813.659.9197
 TEXAS BOARD OF PROFESSIONAL ENGINEERS
 CERTIFICATE OF REGISTRATION # F-11852

PRODUCT:	FIBERGLASS DOOR
PART OR ASSEMBLY:	FRAME ANCHORING

NO.	DATE	REVISIONS
3	10/26/21	UPDATE TO 2018 IBC/IRC
2	5/31/18	ADD FLAT FRAME LITE PROFILE
1	12/14/15	ADD H.S. GLAZING OPTION

DATE:	6/13/13
SCALE:	N.T.S.
DWG. BY:	JK
CHK. BY:	LFS
DRAWING NO.:	TX-4374
SHEET	8 OF 9

Z:\Clients\ODL, Inc. PERMANENT\B - Texas Dept of Ins\TDI - 692\Drawings\TX-4374-75.dwg

BILL OF MATERIALS

ITEM #	DESCRIPTION	MATERIAL
B	2X FRAMING (G >= 0.42)	WOOD
C	1/4" MAX. SHIM SPACE	-
D	1/4" PFH DeWALT OR ITW CONCRETE SCREW (1-3/4" MIN. EMB.)	STEEL
J	#10 X 3" PFH WOOD SCREW (1-1/2" MIN. EMB.)	STEEL
L	#10 X 2-1/2" PFH WOOD SCREW (1.15" MIN. EMB.)	STEEL
1	HEAD & JAMB - FINGER-JOINT PINE (G >= 0.42)	WOOD
2	HEAD & JAMB	COMP
3	INTEGRAL MULLION - FAT BOY (PINE)	WOOD
7	WEATHERSTRIP	FOAM
8	DOOR BOTTOM SWEEP	VINYL
9	4" x 4" HINGE	STEEL
11	#9 X 3/4" PFH WOOD SCREW	STEEL
24	#10 X 1-1/2" PFH WOOD SCREW	STEEL
27	LATCH STRIKE PLATE	STEEL
28	DEADBOLT STRIKE PLATE	STEEL
32	#8 X 3" PFH WS	STEEL
34	INSWING THRESHOLD	ALUM/COMP
35	INSWING THRESHOLD	ALUM/COMP
36	INSWING THRESHOLD	ALUM/COMP
37	INSWING SIDELITE SEAT	PVC
38	INSWING SIDELITE SEAT	PVC
39	INSWING SIDELITE SEAT	PVC
40	DOOR PANEL - SEE DOOR PANEL DETAIL SHEET FOR DETAILS	-
50	SIDELITE PANEL - SEE SIDELITE PANEL DETAIL SHEET FOR DETAILS	-
58	#8 X 2-1/2" PFH WOOD SCREW	STEEL

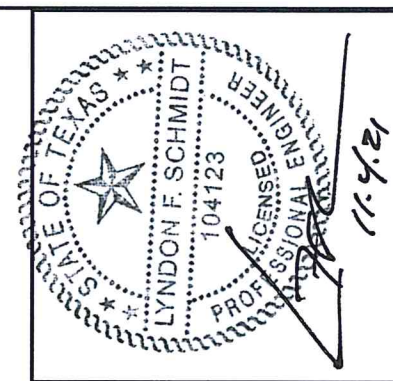
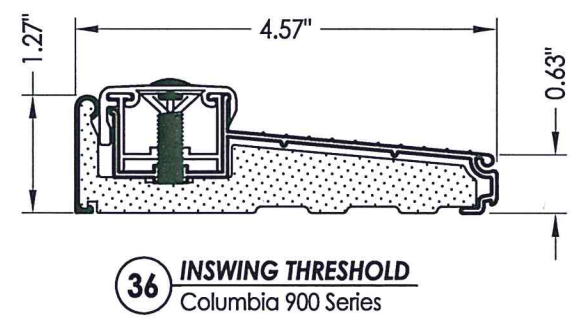
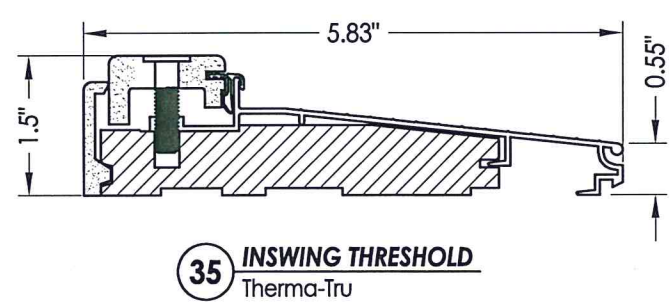
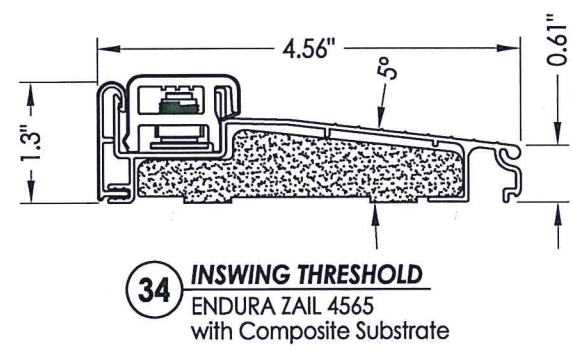
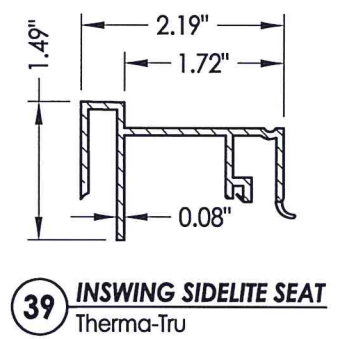
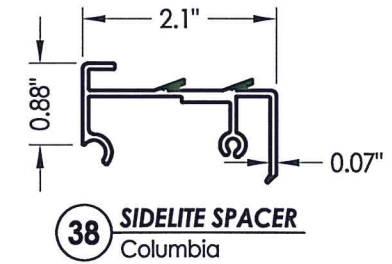
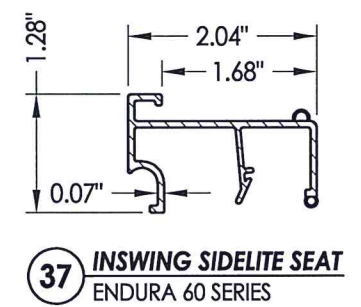
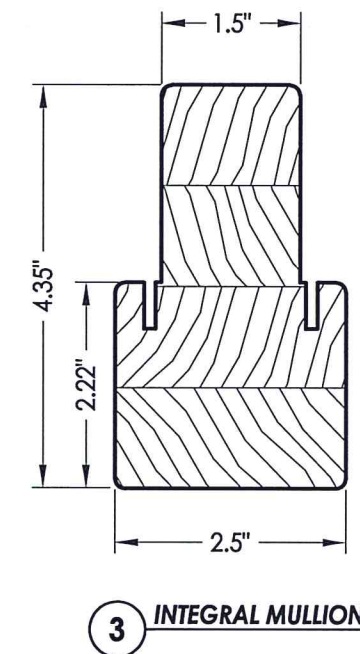
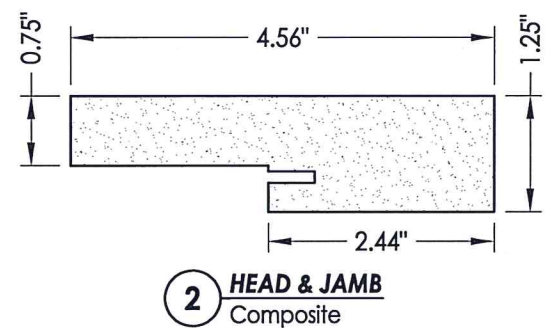
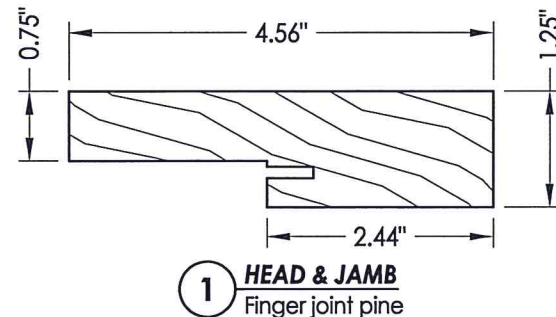

Documents Prepared By: Lyndon F. Schmidt, P.E.
TEXAS P.E. #104123

RW BUILDING CONSULTANTS, INC.
P.O. Box 230 Valrico FL 33595
Phone No.: 813.659.9197

TEXAS BOARD OF PROFESSIONAL ENGINEERS
CERTIFICATE OF REGISTRATION # F-11852

PRODUCT: FIBERGLASS DOOR

PART OR ASSEMBLY: BILL OF MATERIALS & COMPONENTS

NO.	DATE	BY	REVISIONS
3	10/26/21	LFS	UPDATE TO 2018 IRC/IBC
2	5/31/18	LFS	ADD FLAT FRAME LITE PROFILE
1	12/14/15	JK	ADD H.S. GLAZING OPTION

DATE: 6/13/13

SCALE: N.T.S.

DWG. BY: JK

CHK. BY: LFS

DRAWING NO.: TX-4374

SHEET 9 OF 9