



# Glazed Steel Door

"NON-IMPACT"  
INSWING / OUTSWING

**EVALUATED FOR USE IN THE STATE OF TEXAS**

The Glazed Steel Door system described herein complies with the 2018 International Residential Code (IRC), Sections R301 & R609 and the 2018 International Building Code (IBC), Sections 1404.13, 1609, 1709.5, 2403 and 2404 subject to the following conditions:

1. Anchors shall be as listed and spaced as shown in the details. Anchor embedment to base material shall be beyond wall dressing or stucco.
2. When used in areas requiring wind-borne debris protection this product is required to be protected with an impact resistant covering that complies with Section R301.2.1.2 of the IRC and Section 1609.2 of the IBC.
3. Allowable design pressure requirements must be equal to or less than the design pressure rating shown in the design pressure chart, sheet 1 of this drawing.
4. Conditions not covered by this drawing are subject to further engineering analysis.

**TABLE OF CONTENTS**

SHEET#	DESCRIPTION
1	Typical elevations, design pressures & general notes
2	Door panel details (lip lite insert glazing)
3	Slidelite panel details (lip lite insert glazing)
4	Horizontal cross sections
5	Vertical cross sections
6	Vertical cross sections
7	Frame anchoring

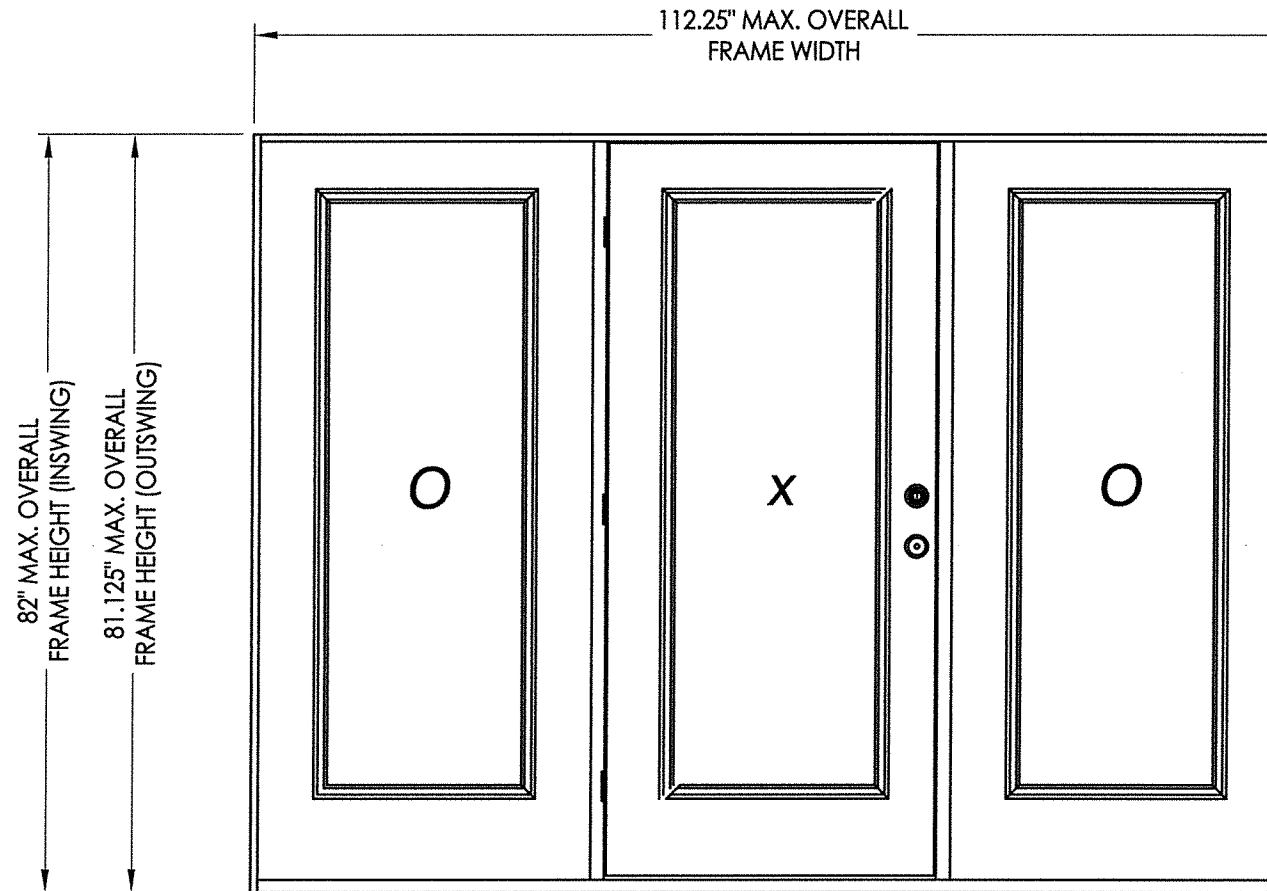

CONFIG.	MODEL	DESIGN PRESSURE (PSF)	
		POSITIVE	NEGATIVE
OXO	INSWING	+50.0	-55.0
	OUTSWING	+45.0	-45.0

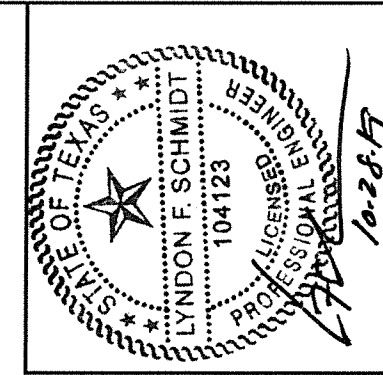

Documents Prepared By: Lyndon F. Schmidt, P.E.  
TEXAS P.E. #104123

**RW** BUILDING CONSULTANTS, INC.  
P.O. Box 230 Valrico FL, 33595  
Phone No.: 813.659.9197

TEXAS BOARD OF PROFESSIONAL ENGINEERS  
CERTIFICATE OF REGISTRATION # F-11852

PRODUCT: ENDURA  
PART OR ASSEMBLY:  
TYPICAL ELEVATION, DESIGN PRESSURES & GENERAL NOTES

NO.	DATE	REVISIONS
3	10/28/19	ADD "FusionFrame" OPTION & UPDATE TO 2018 IBC/IRC CODE
2	11/01/16	ADDED THRESHOLDS
1	12/03/13	ADDED ARTICULATING SILL

DATE: 7/12/12  
SCALE: N.T.S.  
DWG. BY: JK  
CHK. BY: LFS  
DRAWING NO.: TX-4173  
SHEET 1 OF 7

R:\Clients\Endura PERMANENT\B - Texas Dept of Ins\TDI - DR-585 Masonite Steel\B - Drawings\REV 2018 IBC\TX-4173-74.dwg, 2.3

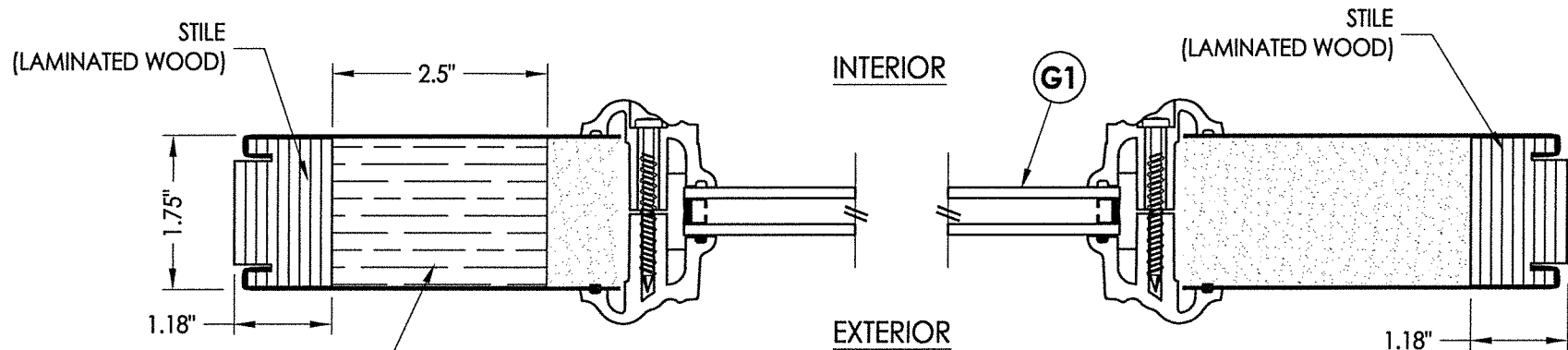

1  
2 **HORIZONTAL CROSS SECTION**

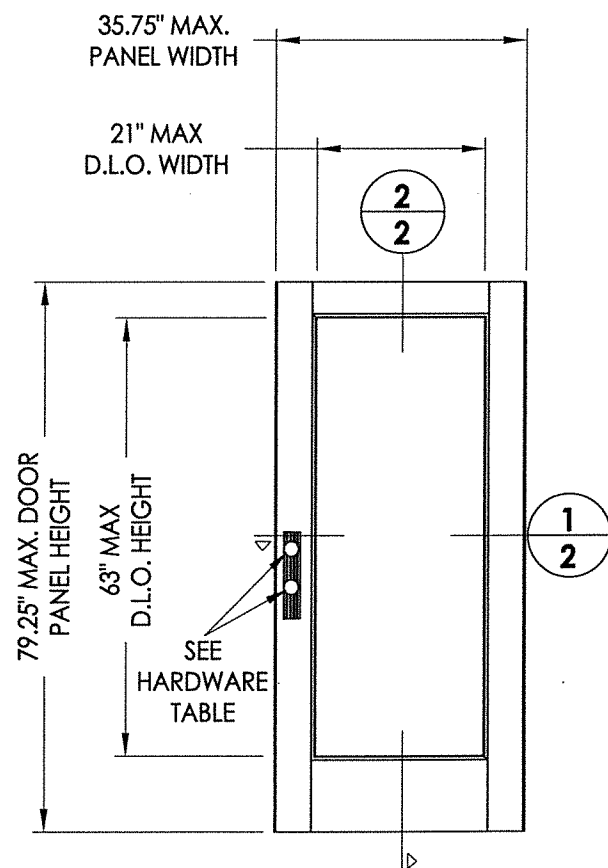

MASONITE  
Insert glazed  
(Steel)

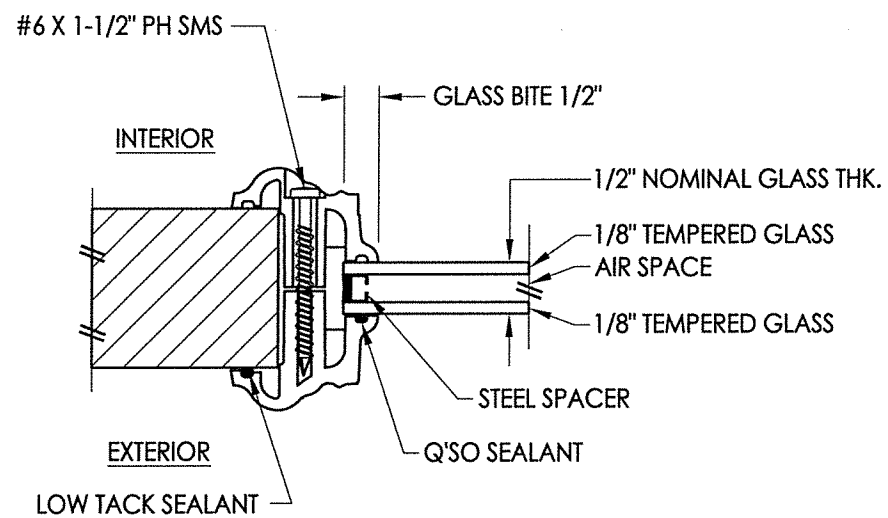

G1 **GLAZING DETAIL**  
Lip Lite Insert Glazing

HARDWARE TABLE	
MANUFACTURER	MODEL
KWIKSET	LATCH: KWIKSET SIGNATURE SERIES (991) DEADBOLT: KWIKSET SIGNATURE SERIES (980/985)

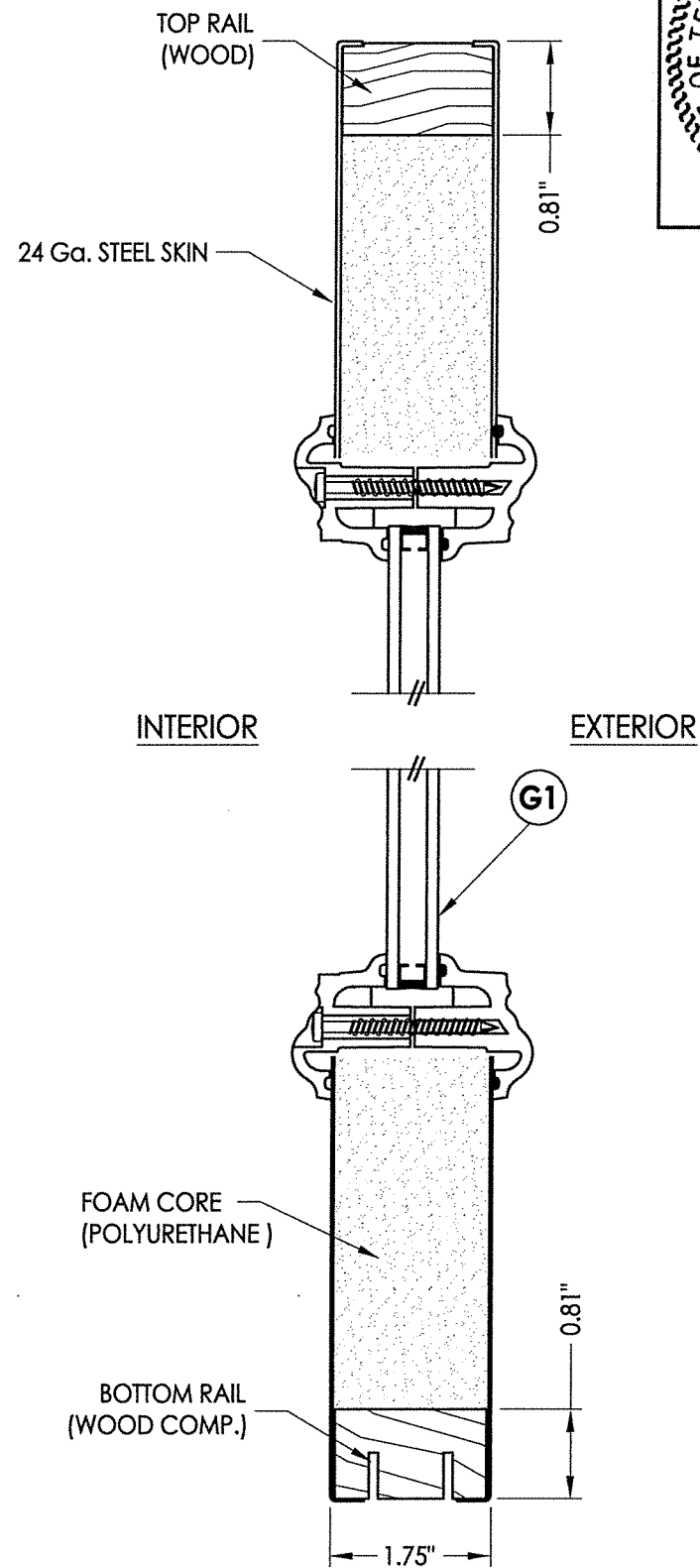

2  
2 **VERTICAL CROSS SECTION**

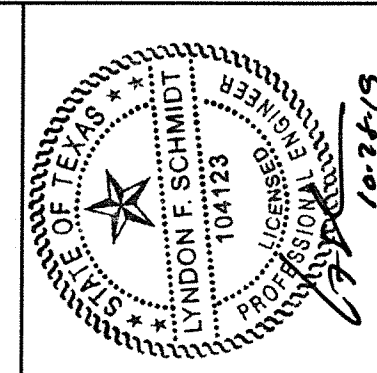

Documents Prepared By: Lyndon F. Schmidt, P.E.  
TEXAS P.E. #104123

**R.W.** BUILDING CONSULTANTS, INC.  
P.O. Box 230 Valrico FL 33595  
Phone No.: 813.659.9197  
TEXAS BOARD OF PROFESSIONAL ENGINEERS  
CERTIFICATE OF REGISTRATION # F-11852

PRODUCT: ENDURA  
PART OR ASSEMBLY: SIDELITE PANEL DETAILS (LIP LITE INSERT GLAZING)

NO.	DATE	REVISIONS
3	10/28/19	ADD "FusionFrame" OPTION & UPDATE TO 2018 IBC/IRC CODE
2	11/01/16	ADDED THRESHOLDS
1	12/03/13	ADDED ARTICULATING SILL
		BY

DATE: 7/12/12

SCALE: N.T.S.

DWG. BY: JK

CHK. BY: LFS

DRAWING NO.:

TX-4173

SHEET 2 OF 7

R:\Clients\Endura PERMANENT\B - Texas Dept of Ins\TDI - DR-585 Masonite Steel\C - Drawings\REV 2018 IBC\TX-4173-74.dwg, 3.3

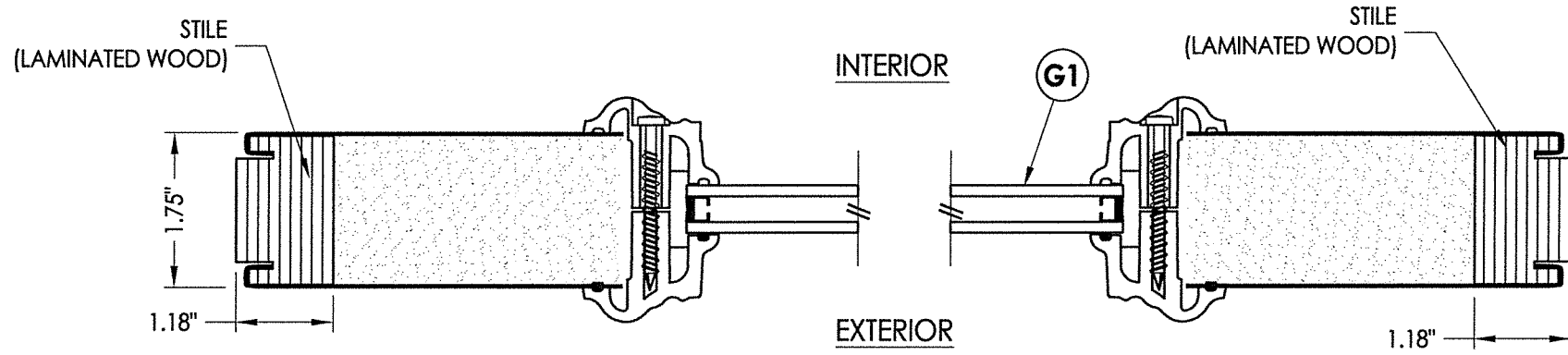

**1**  
**3** HORIZONTAL CROSS SECTION

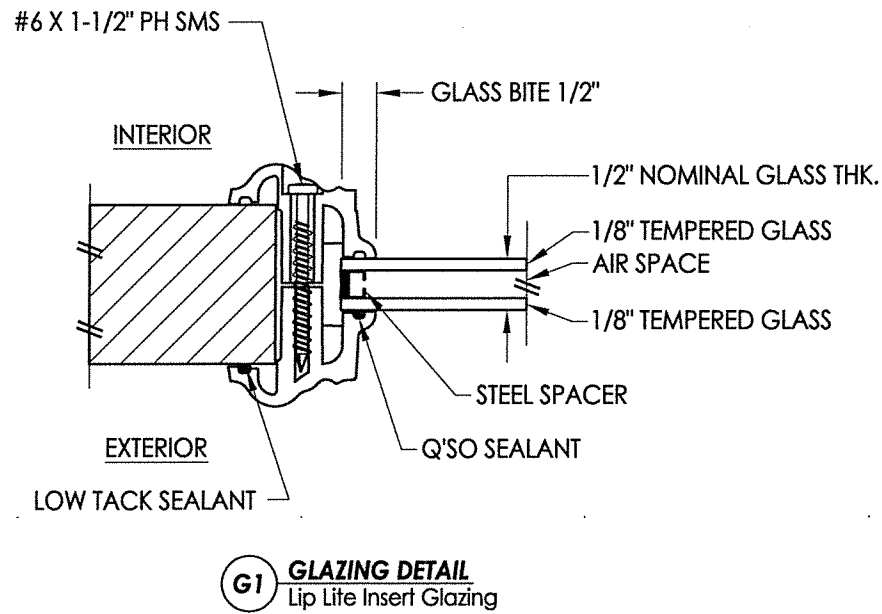
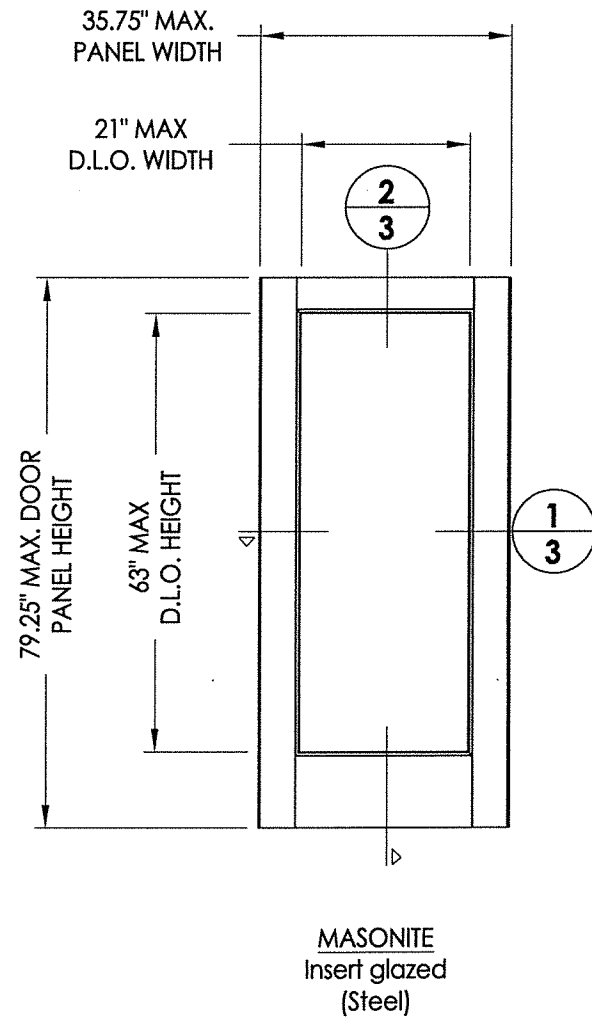

**G1** GLAZING DETAIL  
Lip Lite Insert Glazing

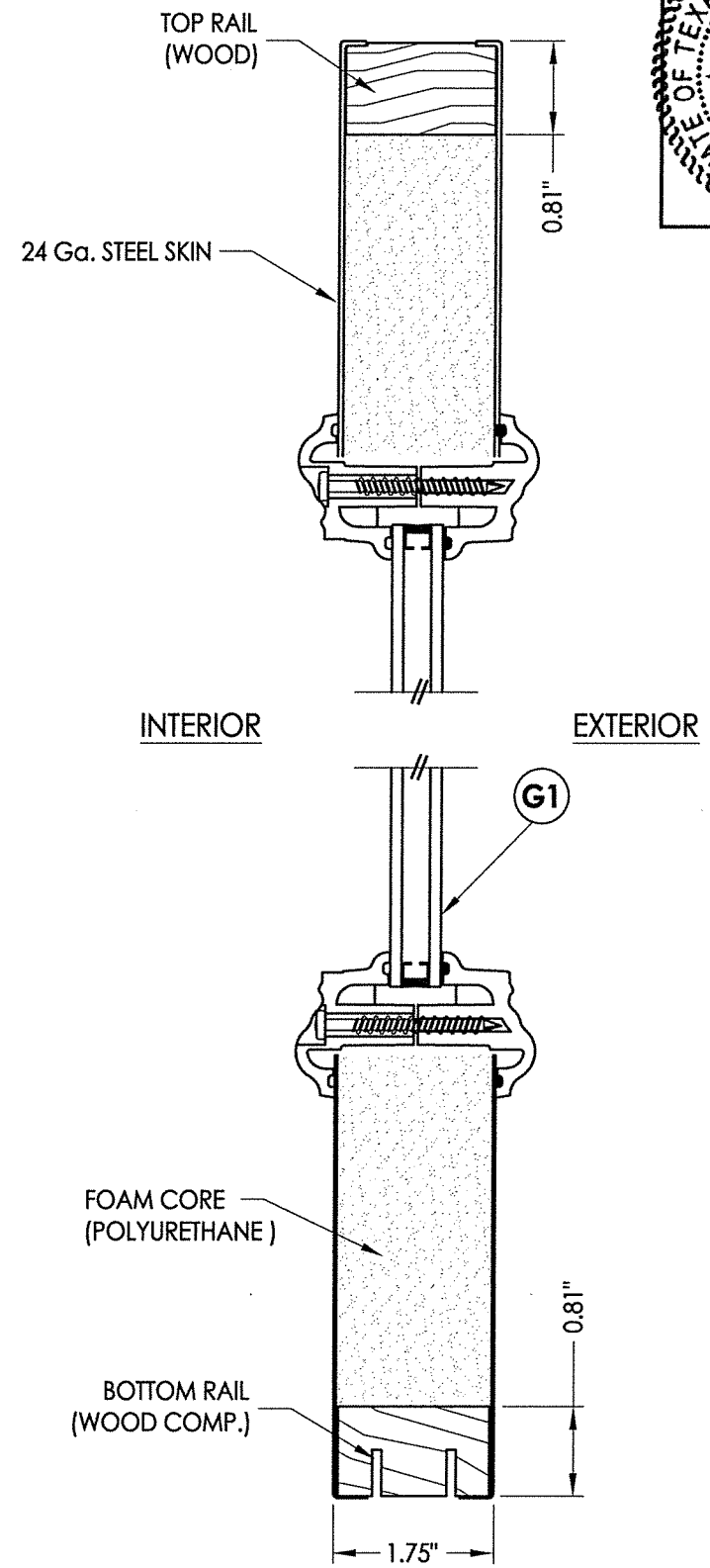

**2**  
**3** VERTICAL CROSS SECTION

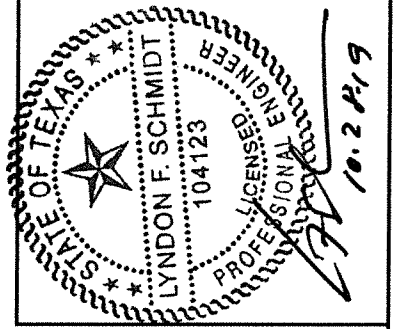

Documents Prepared By: Lyndon F. Schmidt, P.E.  
TEXAS P.E. #104123  
**RW** BUILDING CONSULTANTS, INC.  
P.O. Box 230 Vairico FL 33595  
Phone No.: 813.659.9197  
TEXAS BOARD OF PROFESSIONAL ENGINEERS  
CERTIFICATE OF REGISTRATION # F-11852

PRODUCT: ENDURA  
PART OR ASSEMBLY: SIDELITE PANEL DETAILS (LIP LITE INSERT GLAZING)

NO.	DATE	REVISIONS
3	10/28/19	ADD "FusionFrame" OPTION & UPDATE TO 2018 IBC/IRC CODE
2	11/01/16	ADDED THRESHOLDS
1	12/03/13	ADDED ARTICULATING SILL
		BY

DATE: 7/12/12  
SCALE: N.T.S.  
DWG. BY: JK  
CHK. BY: LFS  
DRAWING NO.: TX-4173  
SHEET 3 OF 7

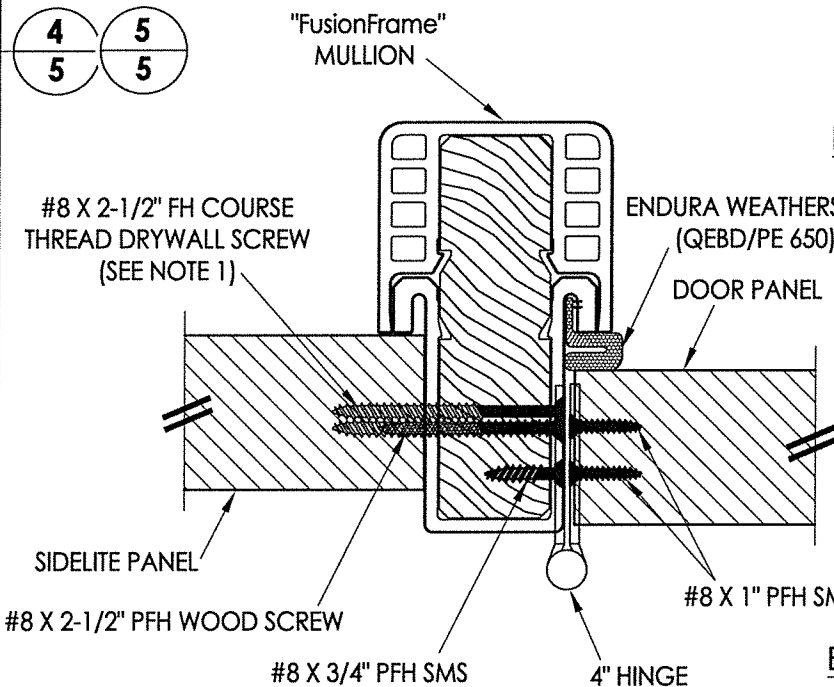
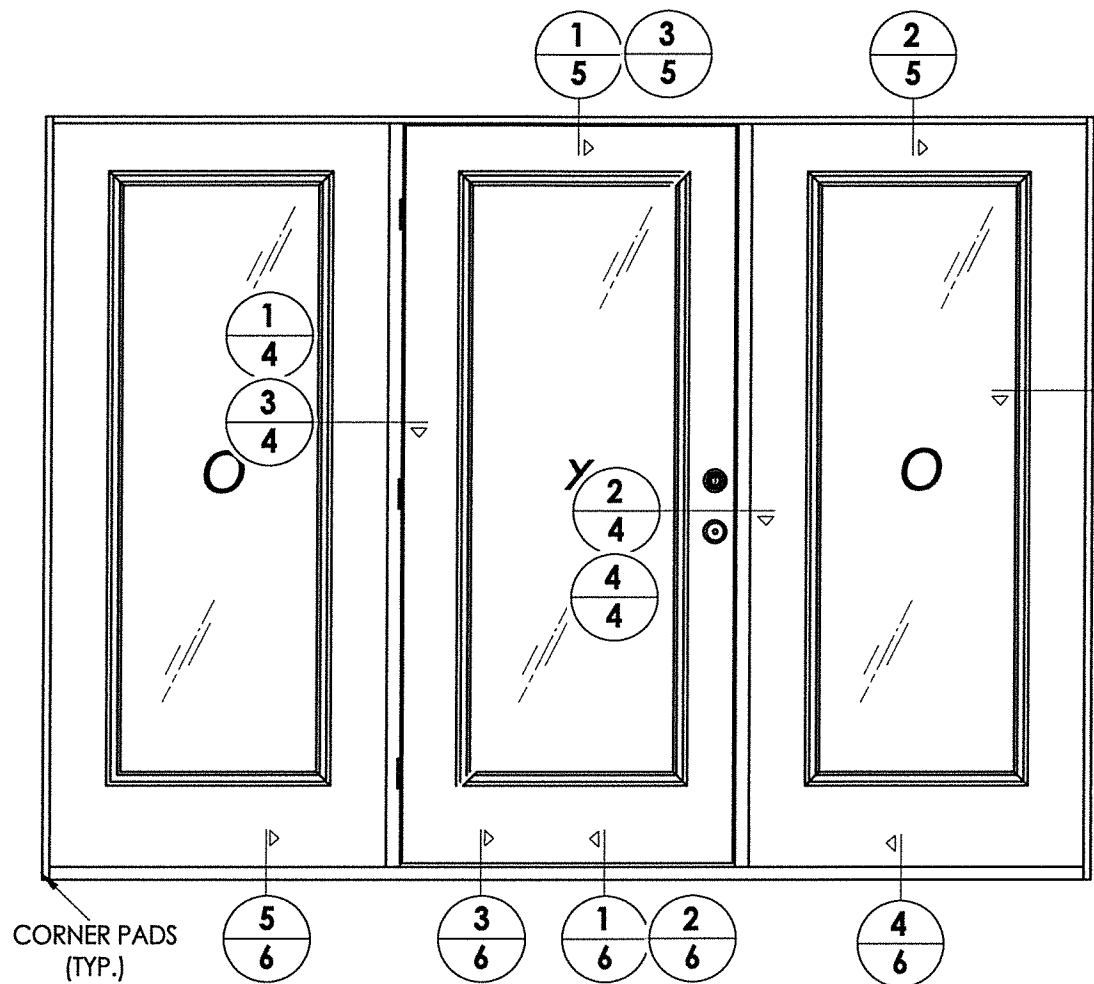

**3 HORIZONTAL CROSS SECTION**  
Outswing shown - Inswing also approved

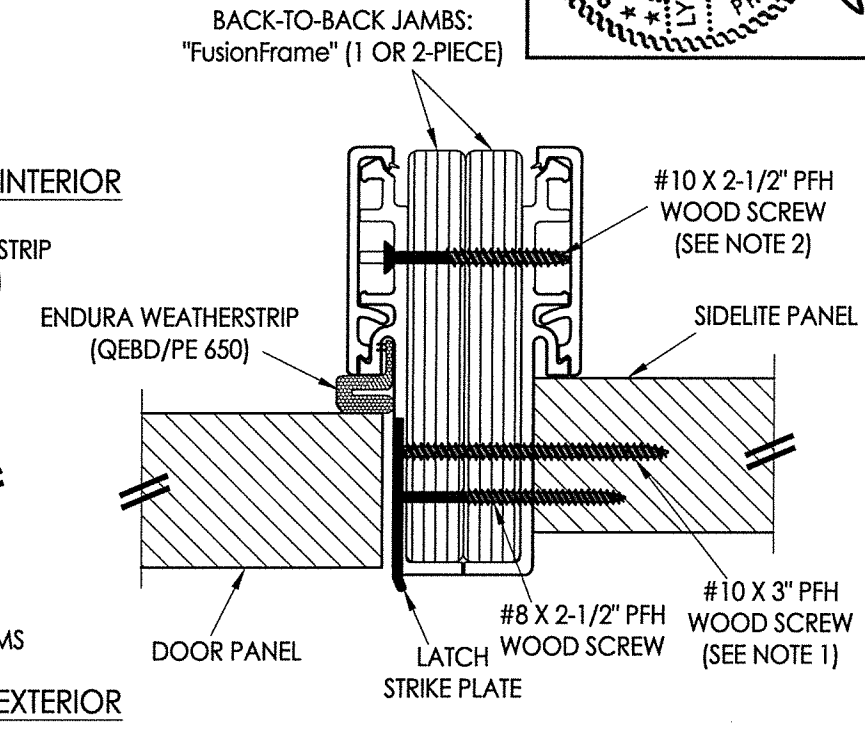

**4 HORIZONTAL CROSS SECTION**  
Outswing shown - Inswing also approved

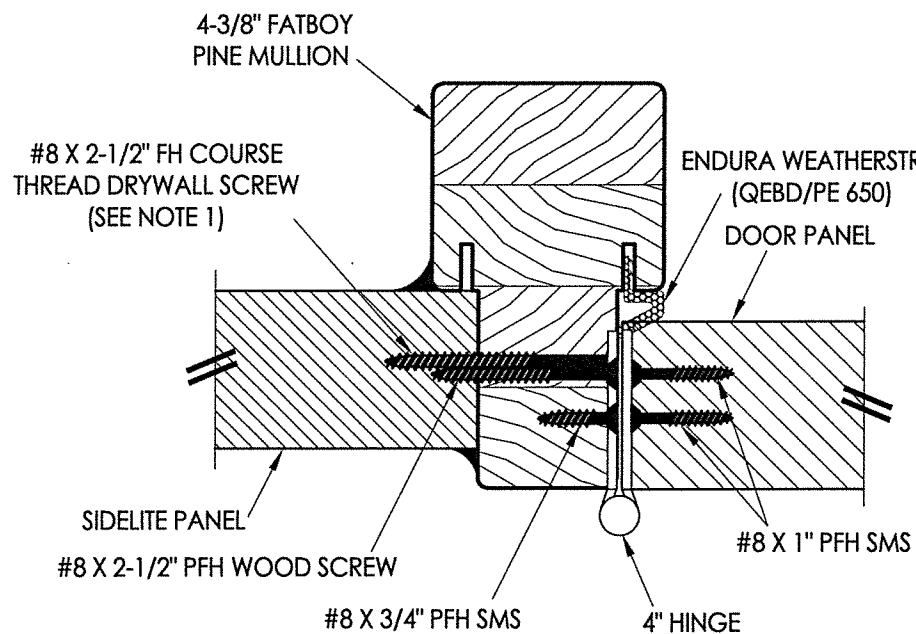
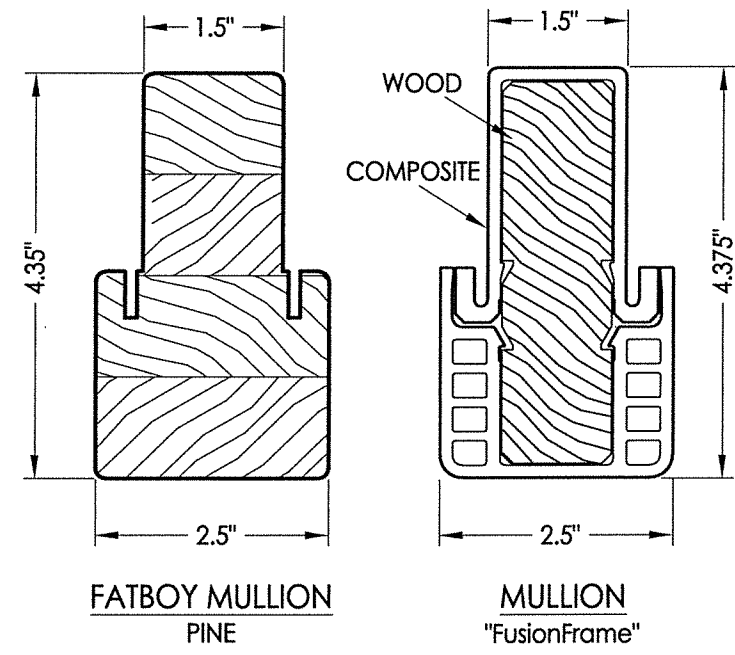

**1 HORIZONTAL CROSS SECTION**  
Outswing shown - Inswing also approved

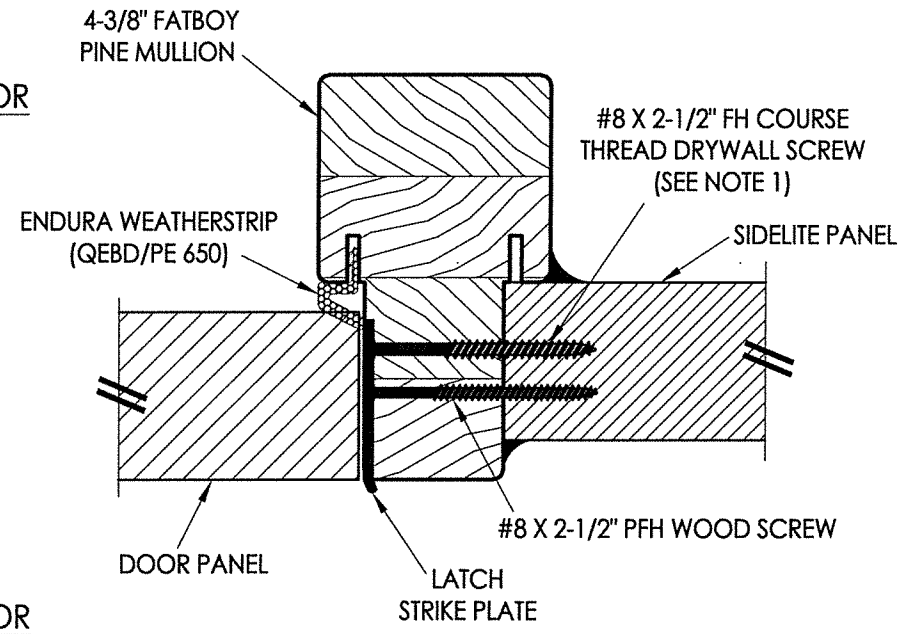

**2 HORIZONTAL CROSS SECTION**  
Outswing shown - Inswing also approved

**NOTES:**  
1. Spacing for sidelite screws: 6.5", 38.5" and 69" from head to sill (3 total).  
2. Spacing for mullion screws: 6" from each end plus 3 more equally spaced (5 total).

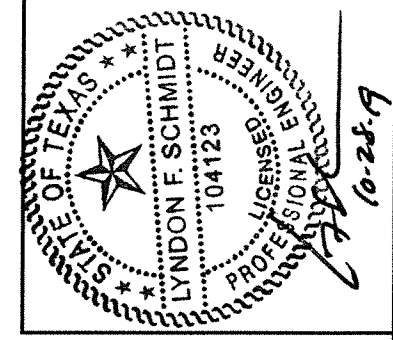

Documents Prepared By: Lyndon F. Schmidt, P.E.  
TEXAS P.E. #104123  
**RW** BUILDING CONSULTANTS, INC.  
P.O. Box 230 Valrico FL 33595  
Phone No.: 813.659.9197  
TEXAS BOARD OF PROFESSIONAL ENGINEERS  
CERTIFICATE OF REGISTRATION # F-11852

PRODUCT: ENDURA  
Steel DOOR  
PART OR ASSEMBLY:  
HORIZONTAL CROSS SECTIONS

NO.	DATE	REVISIONS
3	10/28/19	ADD "FusionFrame" OPTION & UPDATE TO 2018 IBC/IRC CODE
2	11/01/16	ADDED THRESHOLDS
1	12/03/13	ADDED ARTICULATING SILL
		BY

DATE: 7/12/12  
SCALE: N.T.S.  
DWG. BY: JK  
CHK. BY: LFS  
DRAWING NO.: TX-4173  
SHEET 4 OF 7

R:\Clients\Endura PERMANENT\B - Texas Dept of Ins\TDI - DR-585 Masonite Steel\C - Drawings\REV 2018 IBC\TX-4173-74.dwg, 5.3

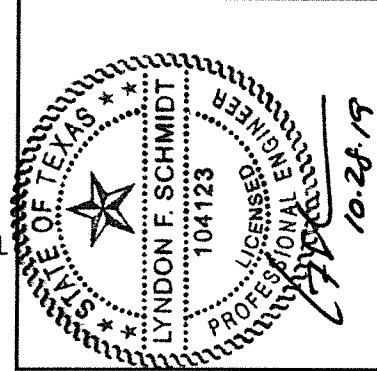
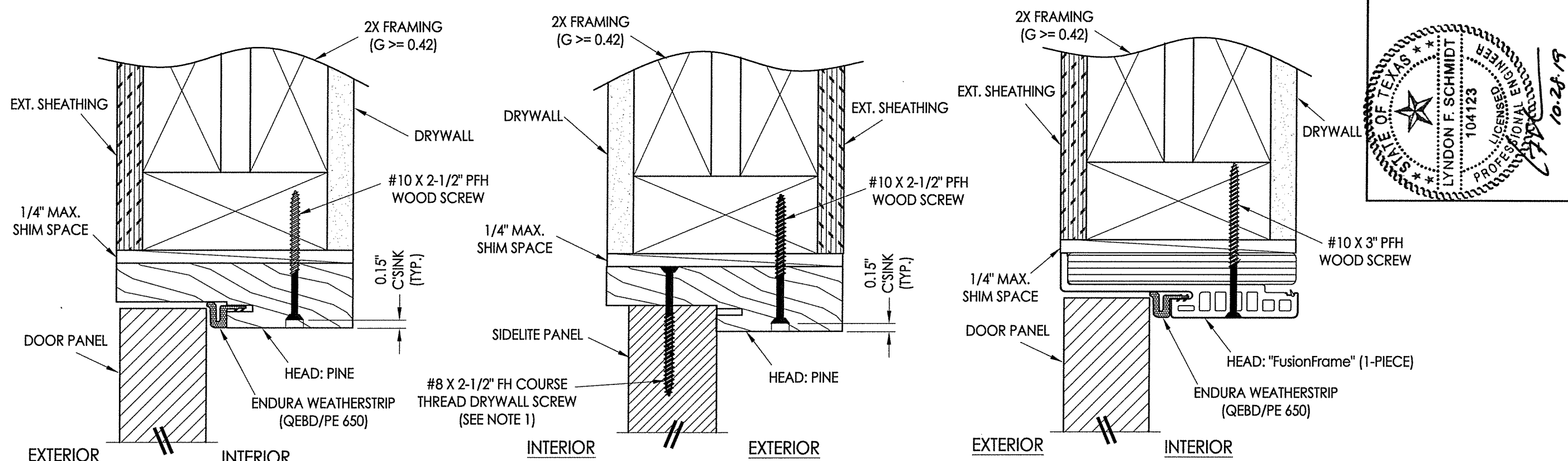

Documents Prepared By: Lyndon F. Schmidt, P.E.  
TEXAS P.E. #104123

**RW** BUILDING CONSULTANTS, INC.  
P.O. Box 230 Valrico FL, 33595  
Phone No.: 813.659.9197

TEXAS BOARD OF PROFESSIONAL ENGINEERS  
CERTIFICATE OF REGISTRATION # F-11852

**1** VERTICAL CROSS SECTION  
**5** Outswing shown - inswing also approved

**2** VERTICAL CROSS SECTION  
**5** Inswing shown - Outswing also approved

**3** VERTICAL CROSS SECTION  
**5** Outswing shown - inswing also approved

NOTE:  
1. Spacing for sidelite screws:  
6" from each end (2 total).

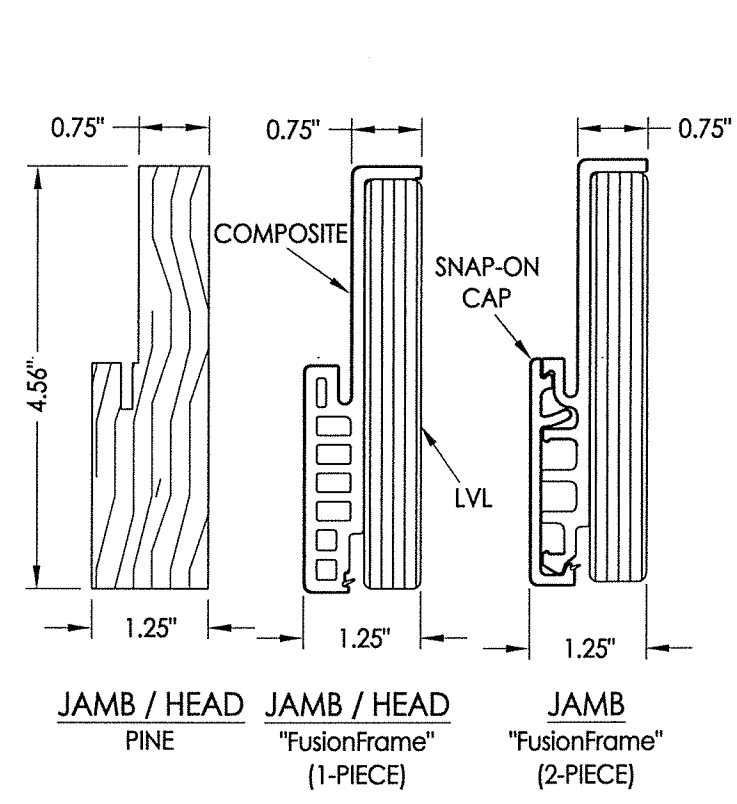

JAMB / HEAD PINE  
JAMB / HEAD "FusionFrame" (1-PIECE)  
JAMB "FusionFrame" (2-PIECE)

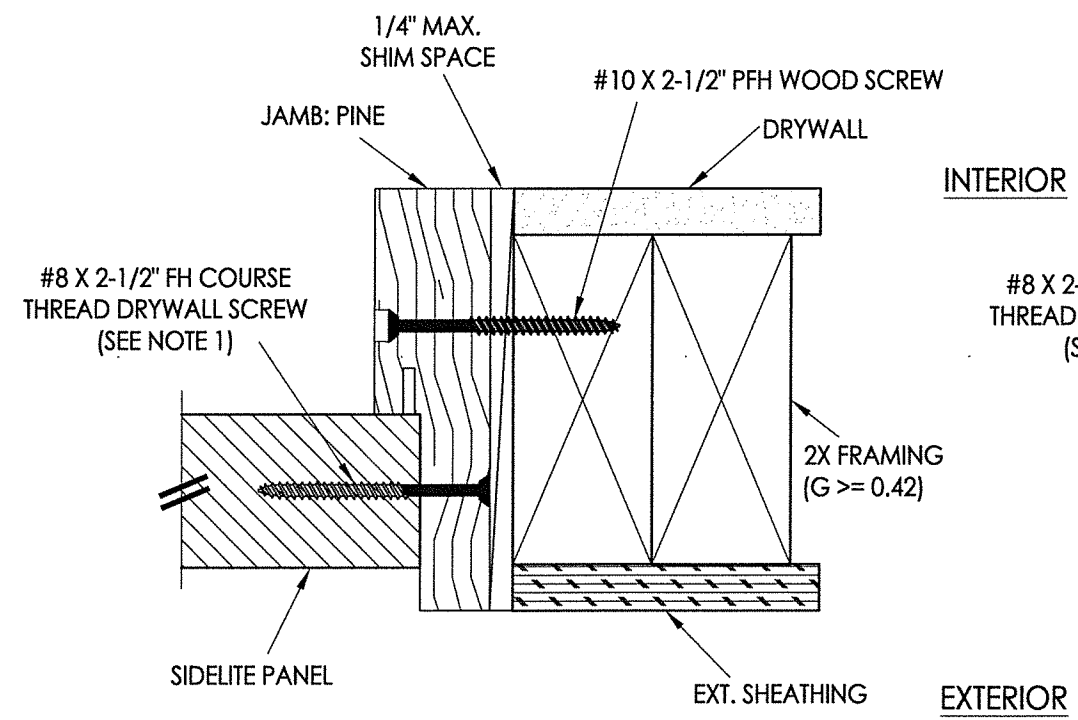

**4** HORIZONTAL CROSS SECTION  
**5** Outswing shown - Inswing also approved

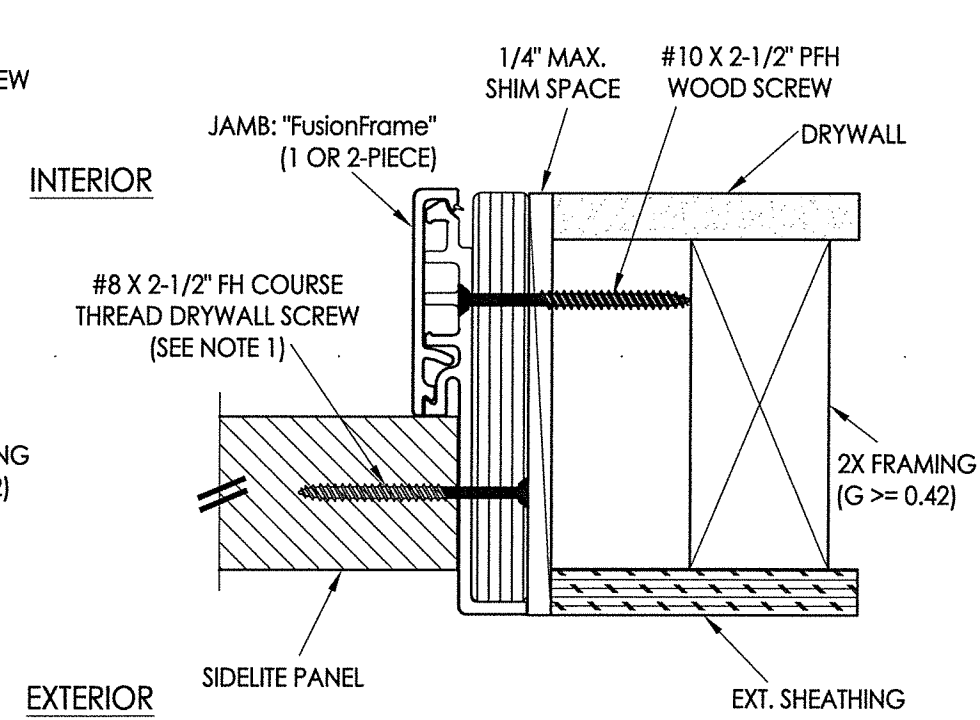

**5** HORIZONTAL CROSS SECTION  
**5** Outswing shown - Inswing also approved

PRODUCT:	ENDURA	
PART OR ASSEMBLY:	VERTICAL CROSS SECTIONS	
NO.	DATE	BY
3	10/28/19	LFS
2	11/01/16	LFS
1	12/03/13	LFS
REVISIONS		
DATE:	7/12/12	
SCALE:	N.T.S.	
DWG. BY:	JK	
CHK. BY:	LFS	
DRAWING NO.:	TX-4173	
SHEET	5	OF 7

R:\Clients\Endura PERMANENT\B - Texas Dept of Ins\TDI - DR-585 Masonite Steel\C - Drawings\REV 2018 IBC\TX-4173-74.dwg, 6.3

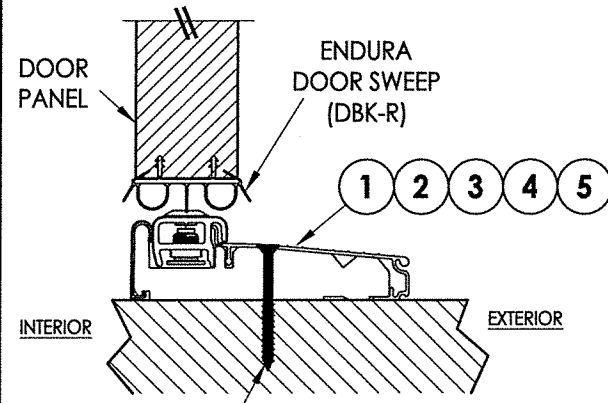

#10 X 2.5" PFH WOOD SCREW OR  
1/4" X 2-3/4" ELCO OR ITW CONCRETE SCREW

**1 VERTICAL CROSS SECTION**  
6 Inswing Adjustable Threshold

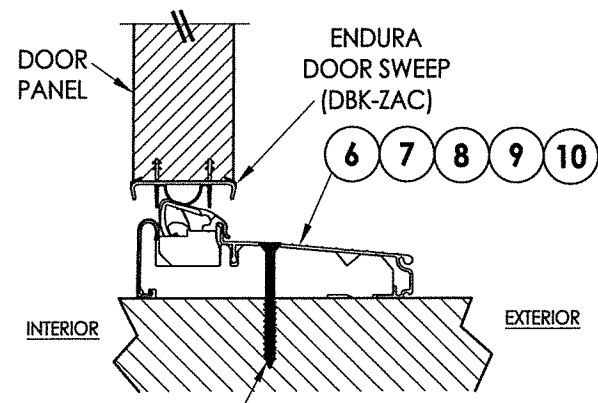

#10 X 2.5" PFH WOOD SCREW OR  
1/4" X 2-3/4" ELCO OR ITW CONCRETE SCREW

**2 VERTICAL CROSS SECTION**  
6 Inswing Articulating Threshold

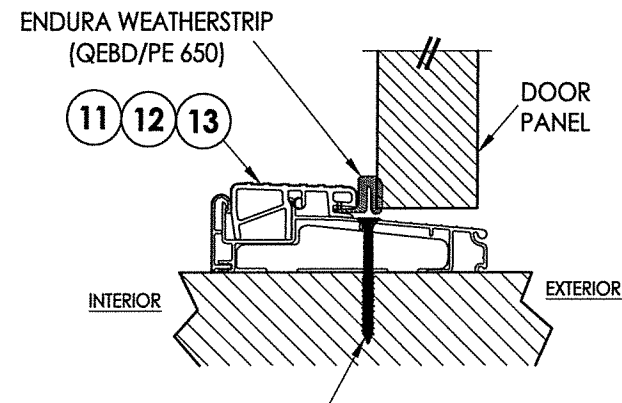

#10 X 2.5" PFH WOOD SCREW OR  
1/4" X 2-3/4" ELCO OR ITW CONCRETE SCREW

**3 VERTICAL CROSS SECTION**  
6 Outswing Bump Threshold

NOTE:  
1. Spacing for sidelite screws:  
6" from each end (2 total).

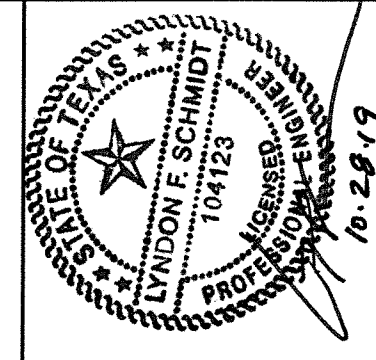

Documents Prepared By: Lyndon F. Schmidt, P.E.  
TEXAS P.E. #104123

**RW** BUILDING CONSULTANTS, INC.  
P.O. Box 230 Vairico FL 33595  
Phone No.: 813.659.9197

TEXAS BOARD OF PROFESSIONAL ENGINEERS  
CERTIFICATE OF REGISTRATION # F-11852

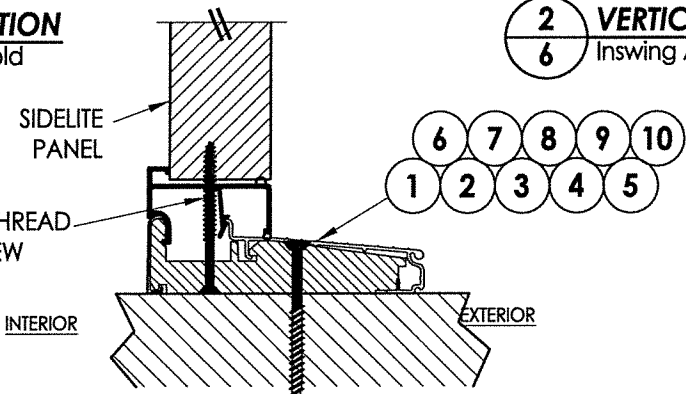

#10 X 2.5" PFH WOOD SCREW OR  
1/4" X 2-3/4" ELCO OR ITW CONCRETE SCREW

**4 VERTICAL CROSS SECTION**  
6 Inswing configuration

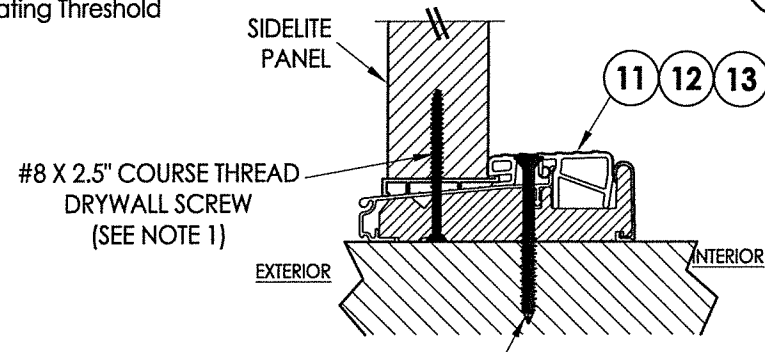

#10 X 2.5" PFH WOOD SCREW OR  
1/4" X 2-3/4" ELCO OR ITW CONCRETE SCREW

**5 VERTICAL CROSS SECTION**  
6 Outswing configuration

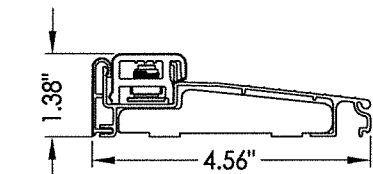

**1 INSWING ADJUSTABLE THRESHOLD**  
ZAIL4565

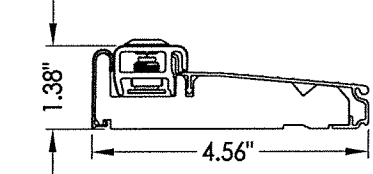

**2 INSWING ADJUSTABLE THRESHOLD**  
ZAI4565FN

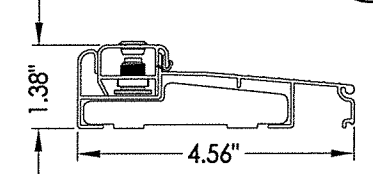

**3 INSWING ADJUSTABLE THRESHOLD**  
ZAILAA4565

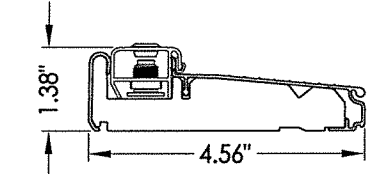

**4 INSWING ADJUSTABLE THRESHOLD**  
ZAI4565FN

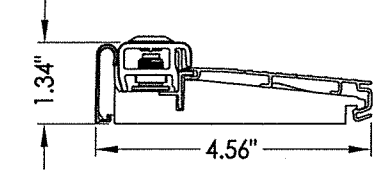

**5 INSWING ADJUSTABLE THRESHOLD**  
ZAI4565RDS

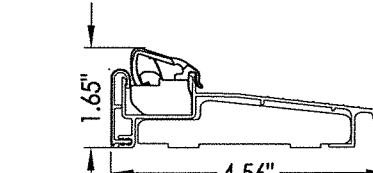

**6 INSWING ARTICULATING THRESHOLD**  
ZACL4565

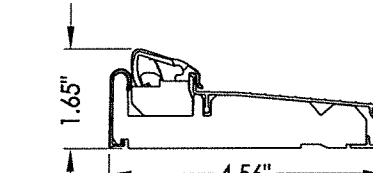

**7 INSWING ARTICULATING THRESHOLD**  
ZAC4565FN

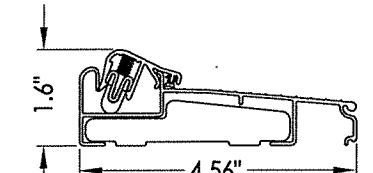

**8 INSWING ARTICULATING THRESHOLD**  
ZACLAA4565

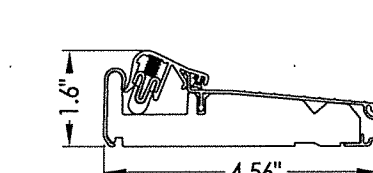

**9 INSWING ARTICULATING THRESHOLD**  
ZACAA4565FN

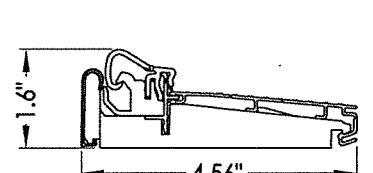

**10 INSWING ARTICULATING THRESHOLD**  
ZAC4565RDS

MAX. DESIGN PRESSURE = ±45 PSF

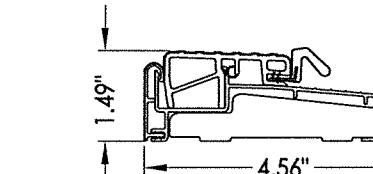

**11 OUTSWING THRESHOLD**  
ZOBL4565

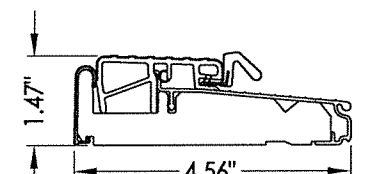

**12 OUTSWING THRESHOLD**  
ZOB4565FN

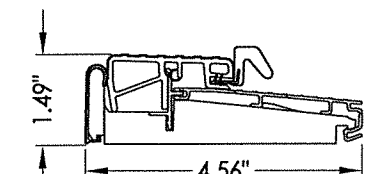

**13 OUTSWING THRESHOLD**  
ZOB4565RDS

PRODUCT:	ENDURA
	FIBERGLASS DOOR
PART OR ASSEMBLY:	VERTICAL CROSS SECTIONS

NO.	DATE	REVISIONS
3	10/28/19	ADD "FusionFrame" OPTION & UPDATE TO 2018 IBC/IRC CODE
2	11/01/16	ADDED THRESHOLDS
1	12/03/13	ADDED ARTICULATING SILL
		BY

DATE:	7/12/12
SCALE:	N.T.S.
DWG. BY:	JK
CHK. BY:	LFS
DRAWING NO.:	TX-4173
SHEET	6 OF 7

© 2012 R.W. BUILDING CONSULTANTS INC.

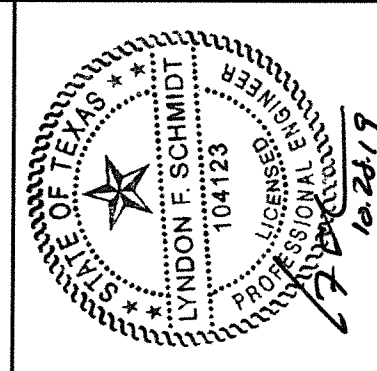

Documents Prepared By: Lyndon F. Schmidt, P.E.  
TEXAS P.E. #104123

**RW** BUILDING CONSULTANTS, INC.  
P.O. Box 230 Valrico FL 33595  
Phone No.: 813.659.9197

TEXAS BOARD OF PROFESSIONAL ENGINEERS  
CERTIFICATE OF REGISTRATION # F-11852

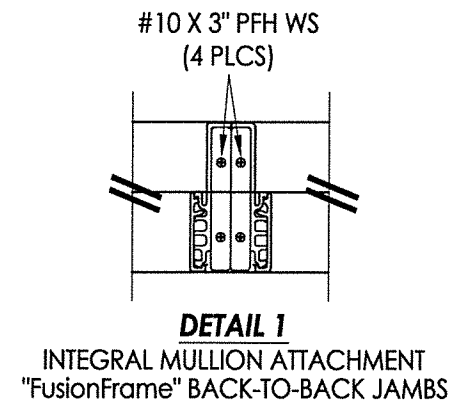
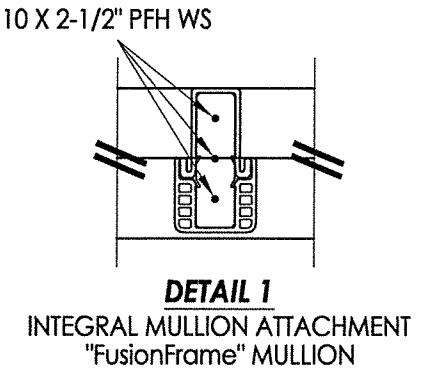
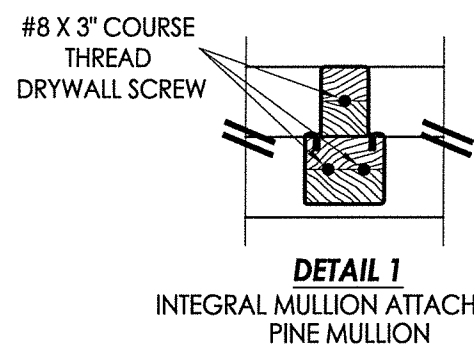
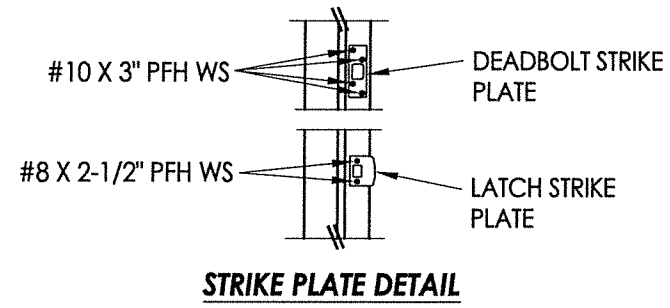
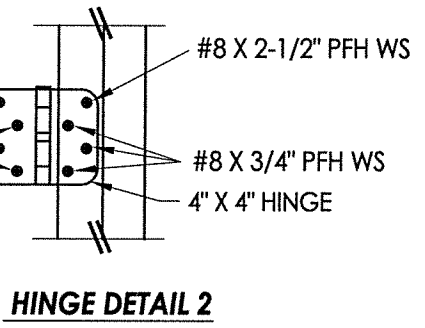
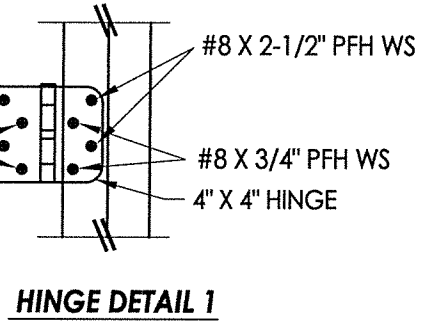
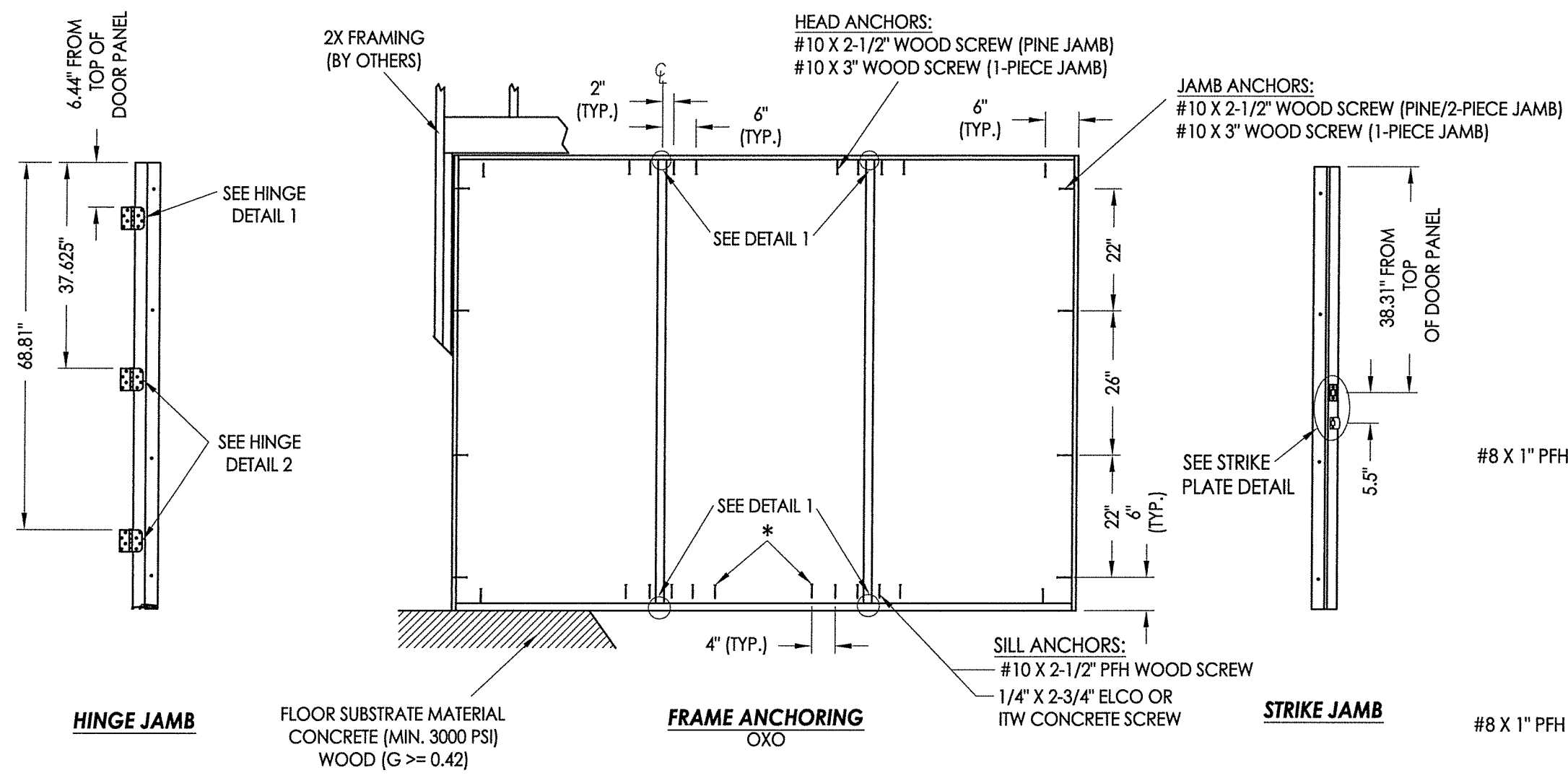

**JAMB NOTES:**  
THE PINE OR "FusionFrame" 1-PIECE JAMB MAY BE INSTALLED @ THE HEAD OR SIDE JAMB.  
THE FusionFrame" 2-PIECE JAMB MAY BE INSTALLED @ THE SIDE JAMBS ONLY.

**INTEGRAL MULLION NOTES:**  
THE FATBOY PINE MULLION, "FusionFrame" MULLION, OR THE "FusionFrame" BACK-TO-BACK JAMB (1-PIECE OR 2-PIECE) MAY ALL BE USED AS THE INTEGRAL MULLION.

**CONCRETE ANCHOR NOTES:**

1. Concrete anchor locations at the corners may be adjusted to maintain the min. edge distance to mortar joints.
2. Concrete anchor locations noted as "MAX. ON CENTER" must be adjusted to maintain the min. edge distance to mortar joints, additional concrete anchors may be required to ensure the "MAX. ON CENTER" dimension are not exceeded.
3. Concrete anchor table:

ANCHOR TYPE	ANCHOR SIZE	MIN. EMBEDMENT	MIN. CLEARANCE TO MASONRY EDGE	MIN. CLEARANCE TO ADJACENT ANCHOR
ITW TAPCON®	1/4"	1-3/4"	2-1/2"	3"
ELCO ULTRACON®	1/4"	1-3/4"	1"	3"

\* NOTE: These anchors required for D.P. > 40 PSF.

PRODUCT:	ENDURA
PART OR ASSEMBLY:	FRAME ANCHORING
REVISIONS	
NO.	DATE
3	10/28/19
2	11/01/16
1	12/03/13
DATE:	7/12/12
SCALE:	N.T.S.
DWG. BY:	JK
CHK. BY:	LFS
DRAWING NO.:	TX-4173
SHEET	7 OF 7