

PERFORMANCE STANDARD

Glazed Fiberglass Door

"NON-IMPACT"
IN SWING / OUT SWING

EVALUATED FOR USE IN THE STATE OF TEXAS

The Glazed Fiberglass Door system described herein complies with the 2018 International Residential Code (IRC), Sections R301 & R609 and the 2018 International Building Code (IBC), Sections 1404.13, 1609, 1709.5, 2403 and 2404 subject to the following conditions:

1. Anchors shall be as listed and spaced as shown in the details. Anchor embedment to base material shall be beyond wall dressing or stucco.
2. When used in areas requiring wind-borne debris protection this product is required to be protected with an impact resistant covering that complies with Section R301.2.1.2 of the IRC and Section 1609.2 of the IBC.
3. Allowable design pressure requirements must be equal to or less than the design pressure rating shown in the design pressure chart, sheet 1 of this drawing.
4. Conditions not covered by this drawing are subject to further engineering analysis.

TABLE OF CONTENTS	
SHEET#	DESCRIPTION
1	Typical elevations, design pressures & general notes
2	Astragal details (Ultimate Flip Lever)
3	Astragal details (Ultimate Multi-point)
4	Astragal details (Ultimate Hurricane)
5	Door panel details (lip lite insert glazing)
6	Horizontal & vertical cross sections
7	Vertical cross sections
8	Frame anchoring

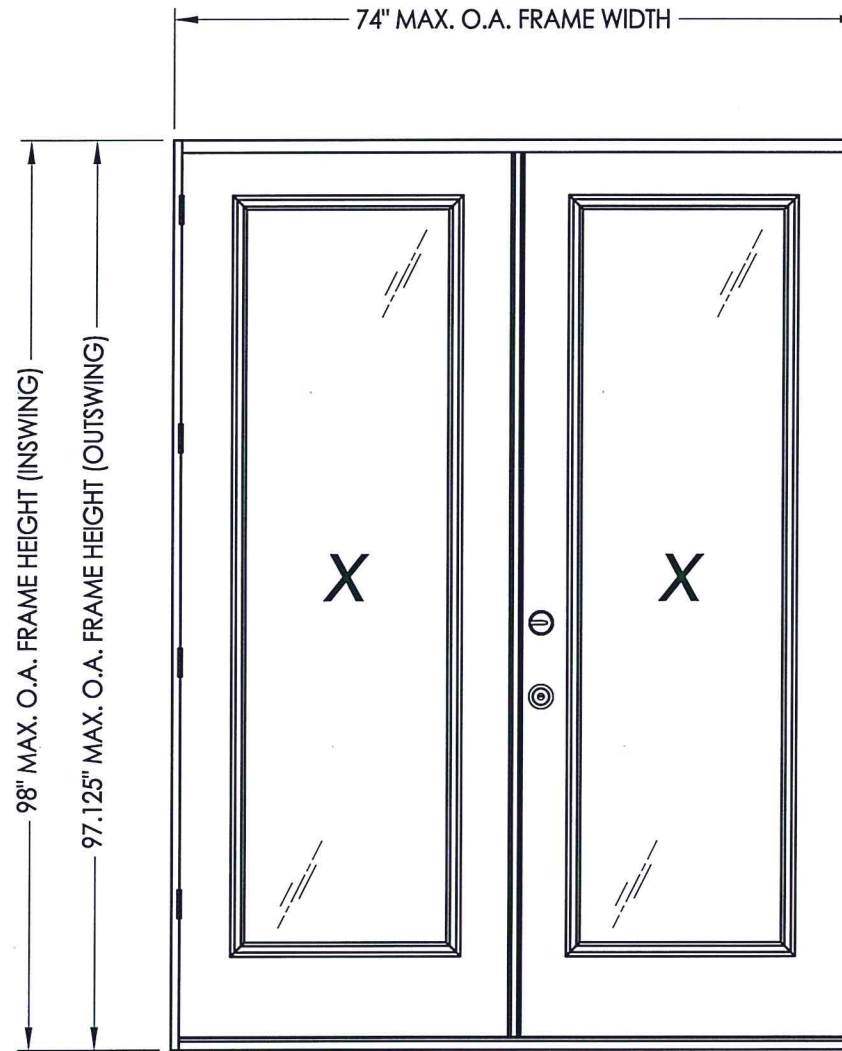

CONFIG.	MODEL	DESIGN PRESSURE (PSF) ULTIMATE HURRICANE ASTRAGAL		DESIGN PRESSURE (PSF) ULTIMATE MULTIPOINT ASTRAGAL		DESIGN PRESSURE (PSF) ULTIMATE FLIP LEVER ASTRAGAL	
		POSITIVE	NEGATIVE	POSITIVE	NEGATIVE	POSITIVE	NEGATIVE
XX	IN SWING	+40.0	-45.0	+40.0	-40.0	+45.0	-50.0
XX	OUT SWING	+40.0	-40.0	+40.0	-40.0	+25.0	-25.0

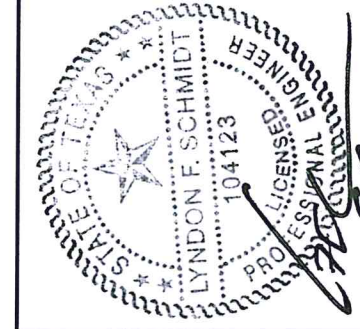

Documents Prepared By: Lyndon F. Schmidt, P.E.
TEXAS P.E. #104123

RW BUILDING CONSULTANTS, INC.
P.O. Box 230 Valrico FL, 33595
Phone No.: 813.659.9197

TEXAS BOARD OF PROFESSIONAL ENGINEERS
CERTIFICATE OF REGISTRATION # F-11852

PRODUCT: ENDURA

PART OR ASSEMBLY: TYPICAL ELEVATION, DESIGN PRESSURES & GENERAL NOTES

NO.	DATE	REVISIONS
5	9/16/19	ADD "FusionFrame" OPTION & UPDATE TO 2018 IBC/IRC CODE
4	11/07/18	REVISED TO INSERT GLAZED ONLY
3	10/25/16	ADDED THRESHOLDS
2	5/5/15	ADD NEW ASTRAGAL PIN CAPTURE
1	11/26/13	ADDED ARTICULATING SILL

DATE: 7/03/12

SCALE: N.T.S.

DWG. BY: JK

CHK. BY: LFS

DRAWING NO.: TX-4165

SHEET 1 OF 8

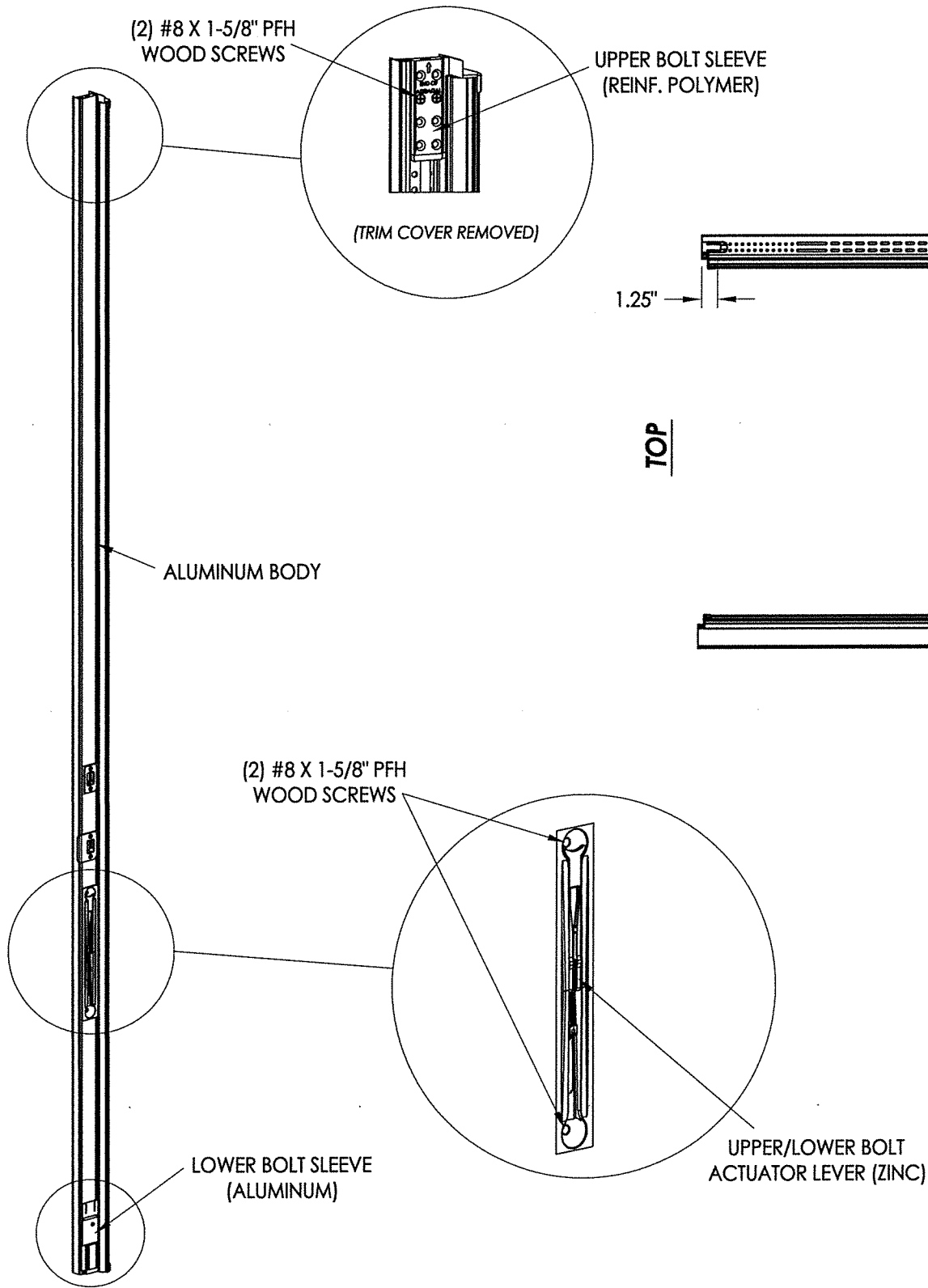

ULTIMATE FLIP LEVER ASTRAGAL

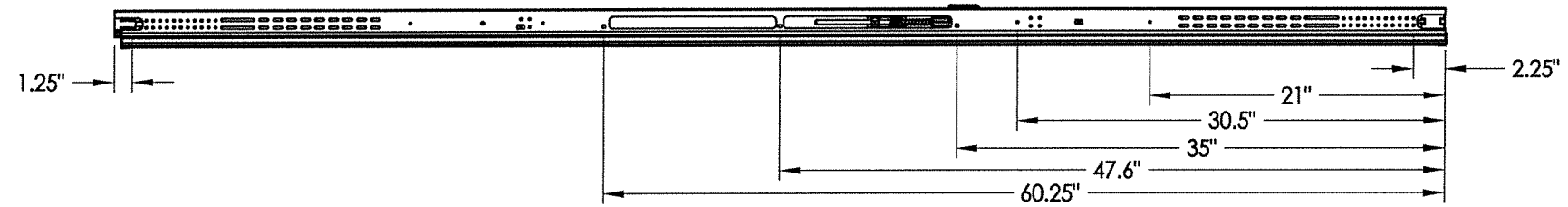

ANCHOR SCREW LOCATIONS

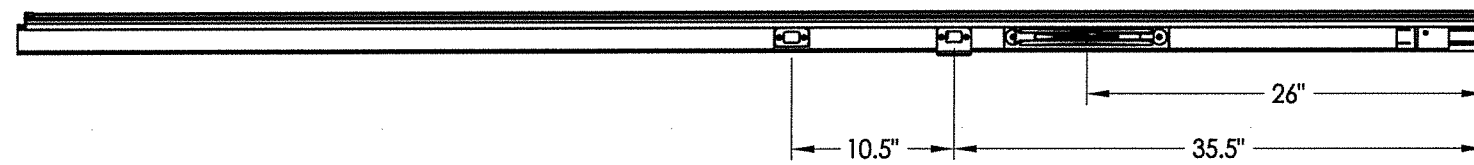

HARDWARE LOCATIONS

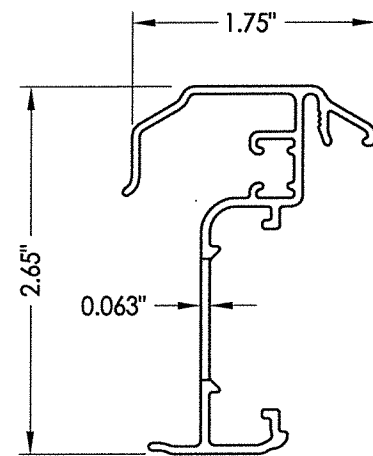

ASTRAGAL SECTION

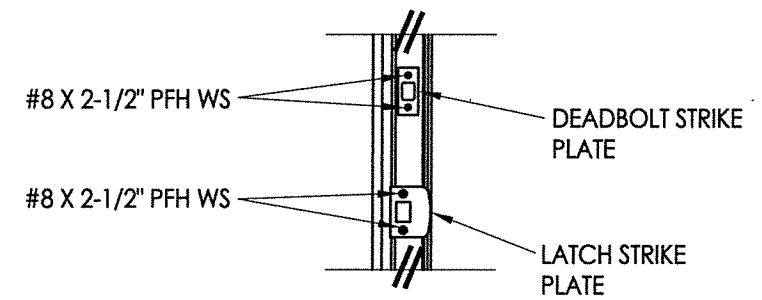

LATCH & DEADBOLT DETAIL

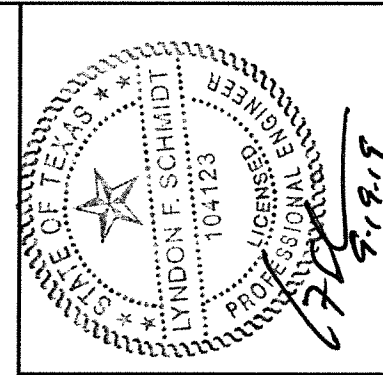

Documents Prepared By: Lyndon F. Schmidt, P.E.
TEXAS P.E. #104123

RW BUILDING CONSULTANTS, INC.
P.O. Box 230 Valrico FL 33595
Phone No.: 813.659.9197

TEXAS BOARD OF PROFESSIONAL ENGINEERS
CERTIFICATE OF REGISTRATION # F-11852

PRODUCT: ENDURA
PART OR ASSEMBLY: ASTRAGAL DETAILS (ULTIMATE FLIP LEVER)

NO.	DATE	REVISIONS	LFS	BY
5	9/16/19	ADD "FusionFrame" OPTION &	LFS	
4	11/07/18	UPDATE TO 2018 IBC/IRC CODE	LFS	
3	10/25/16	REVISED TO INSERT GLAZED ONLY	LFS	
2	5/5/15	ADDED THRESHOLDS	LFS	
1	11/26/13	ADD NEW ASTRAGAL PIN CAPTURE	LFS	
		ADDED ARTICULATING SILL	LFS	

DATE: 7/03/12
SCALE: N.T.S.
DWG. BY: JK
CHK. BY: LFS
DRAWING NO.: TX-4165
SHEET 2 OF 8

R:\Clients\Endura PERMANENT\B - Texas Dept of Ins\TDI - DR-570 (Exp. 11-1-17)\C - Drawings\REV 2018 Insert Glazed\TX-4164-65.dwg, 3.2

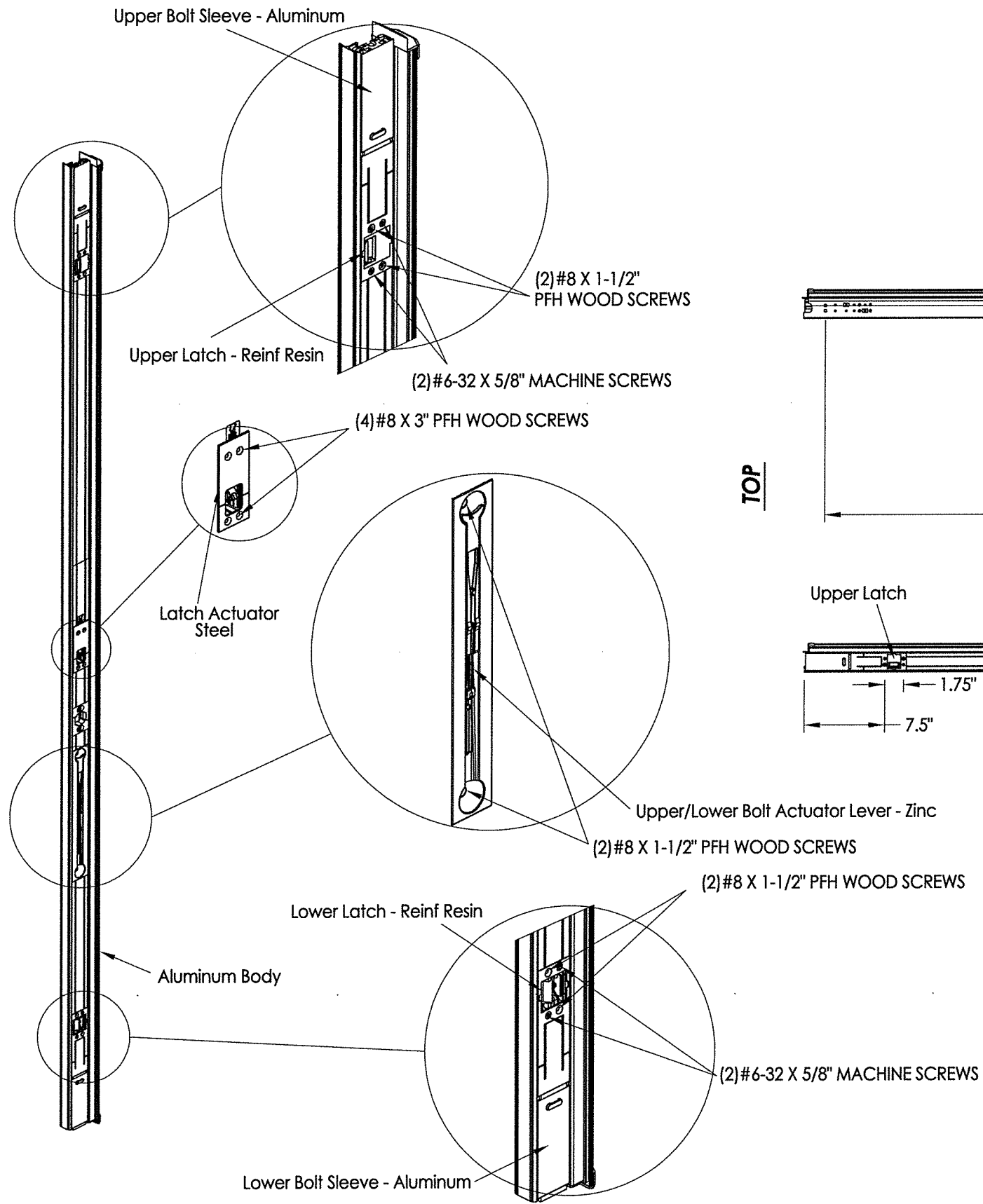

ULTIMATE MULTIPOINT ASTRAGAL

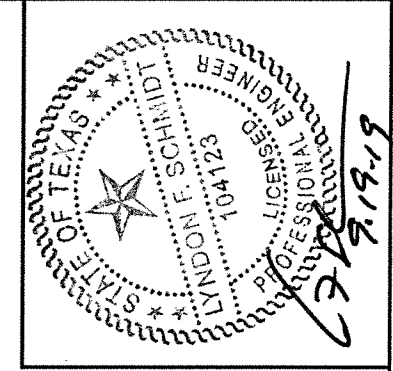
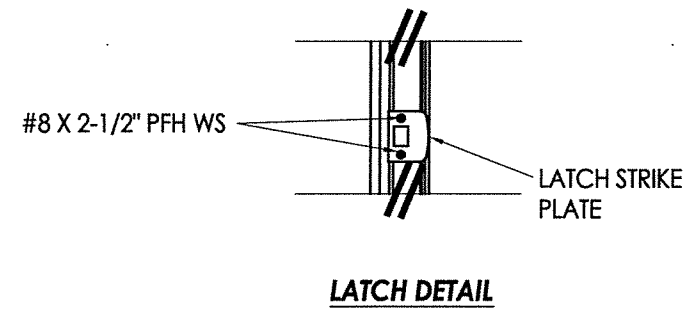
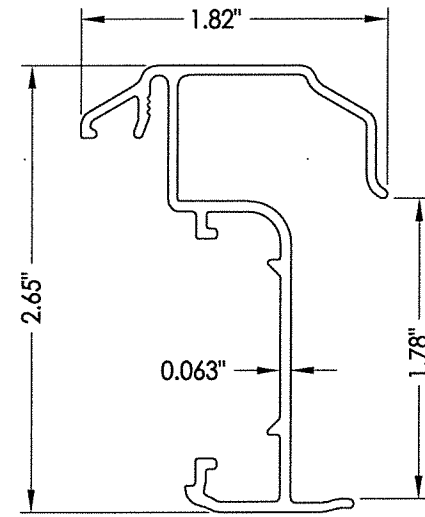
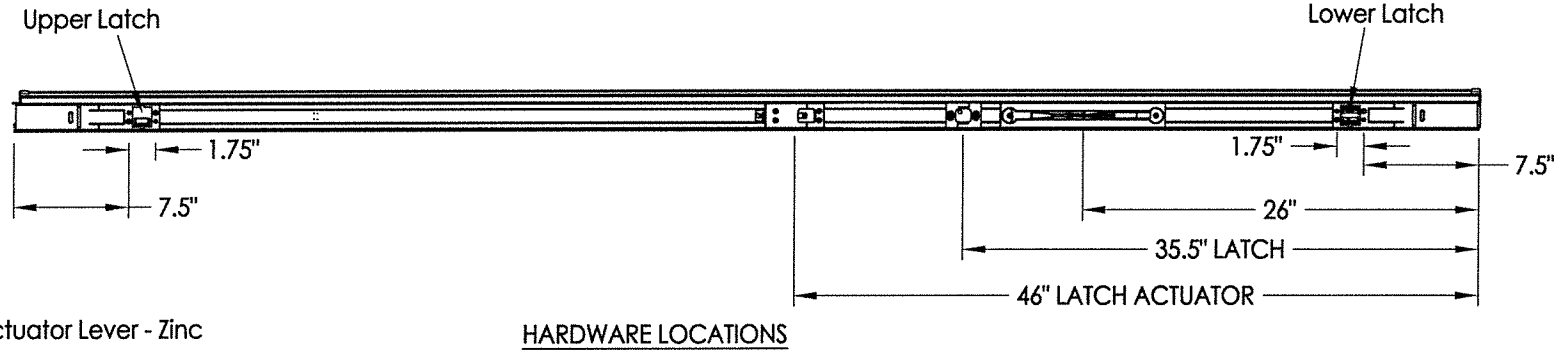
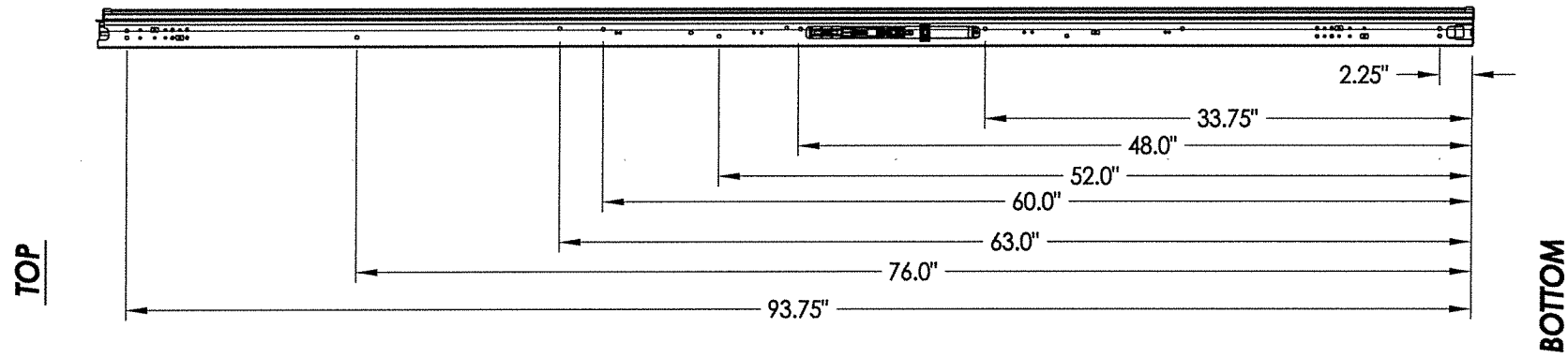

Documents Prepared By: Lyndon F. Schmidt, P.E.
TEXAS P.E. #104123

R.W. BUILDING CONSULTANTS, INC.
P.O. Box 230 Valrico FL, 33595
Phone No.: 813.659.9197

TEXAS BOARD OF PROFESSIONAL ENGINEERS
CERTIFICATE OF REGISTRATION # F-11852

PRODUCT: ENDURA

PART OR ASSEMBLY: ASTRAGAL DETAILS (ULTIMATE MULTI-POINT)

NO.	DATE	REVISIONS
5	9/16/19	ADD "FusionFrame" OPTION & UPDATE TO 2018 IBC/IRC CODE
4	11/07/18	REVISED TO INSERT GLAZED ONLY
3	10/25/16	ADDED THRESHOLDS
2	5/5/15	ADD NEW ASTRAGAL PIN CAPTURE
1	11/26/13	ADDED ARTICULATING SILL

DATE: 7/03/12

SCALE: N.T.S.

DWG. BY: JK

CHK. BY: LFS

DRAWING NO.: TX-4165

SHEET 3 OF 8

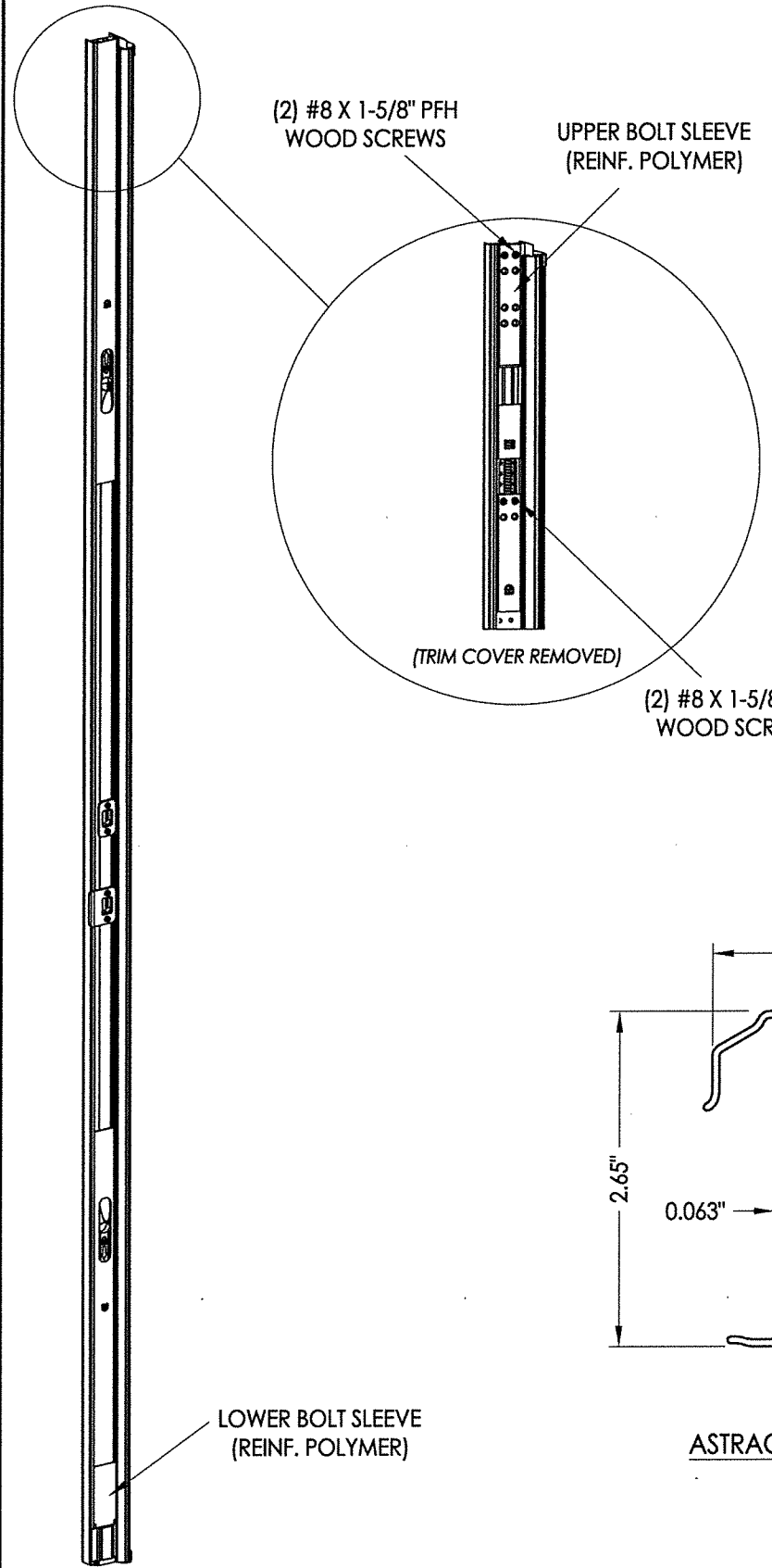

ULTIMATE HURRICANE ASTRAGAL

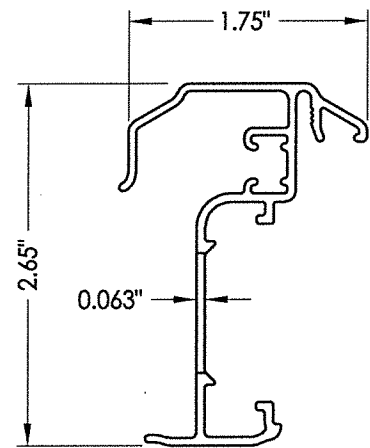
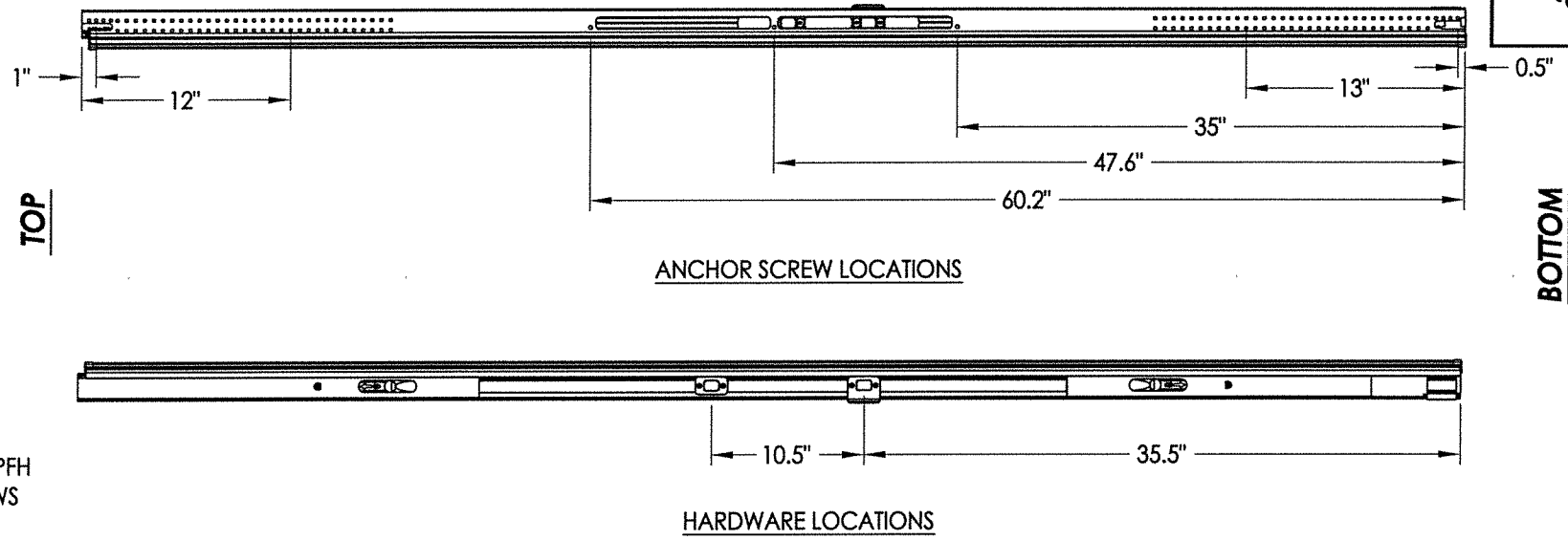

ASTRAGAL SECTION

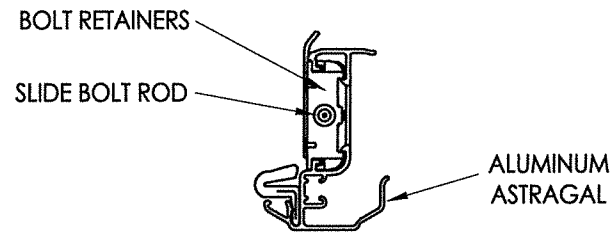
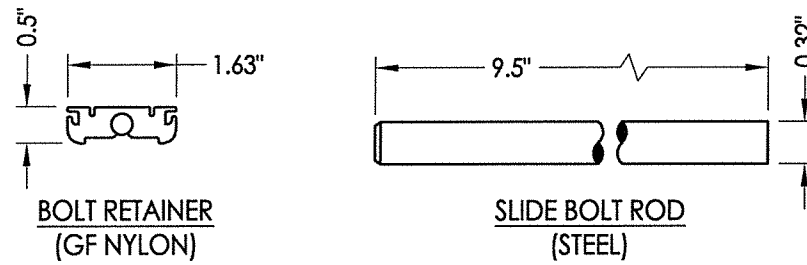

ALUMINUM ASTRAGAL ASSEMBLY

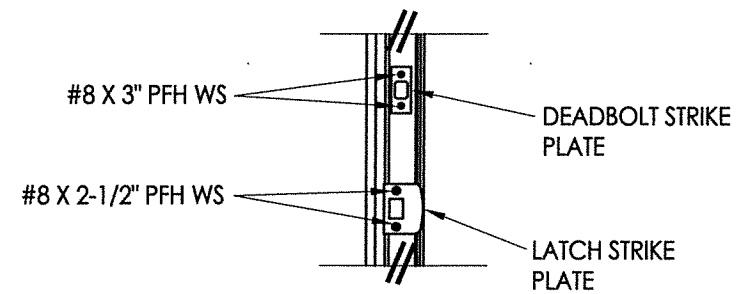

LATCH & DEADBOLT DETAIL

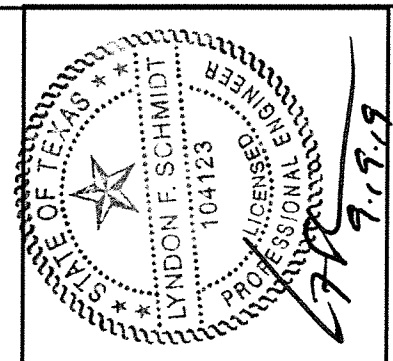

Documents Prepared By: Lyndon F. Schmidt, P.E.
TEXAS P.E. #104123

RW BUILDING CONSULTANTS, INC.
P.O. Box 230 Valrico FL 33595
Phone No.: 813.659.9197

TEXAS BOARD OF PROFESSIONAL ENGINEERS
CERTIFICATE OF REGISTRATION # F-11852

PRODUCT:	ENDURA
PART OR ASSEMBLY:	ASTRAGAL DETAILS (ULTIMATE HURRICANE)

NO.	DATE	REVISIONS	LFS	BY
5	9/16/19	ADD "FusionFrame" OPTION & UPDATE TO 2018 IBC/IRC CODE	LFS	
4	11/07/18	REVISED TO INSERT GLAZED ONLY	LFS	
3	10/25/16	ADDED THRESHOLDS	LFS	
2	5/5/15	ADD NEW ASTRAGAL PIN CAPTURE	LFS	
1	11/26/13	ADDED ARTICULATING SILL	LFS	

DATE:	7/03/12
SCALE:	N.T.S.
DWG. BY:	JK
CHK. BY:	LFS
DRAWING NO.:	TX-4165
SHEET	4 OF 8

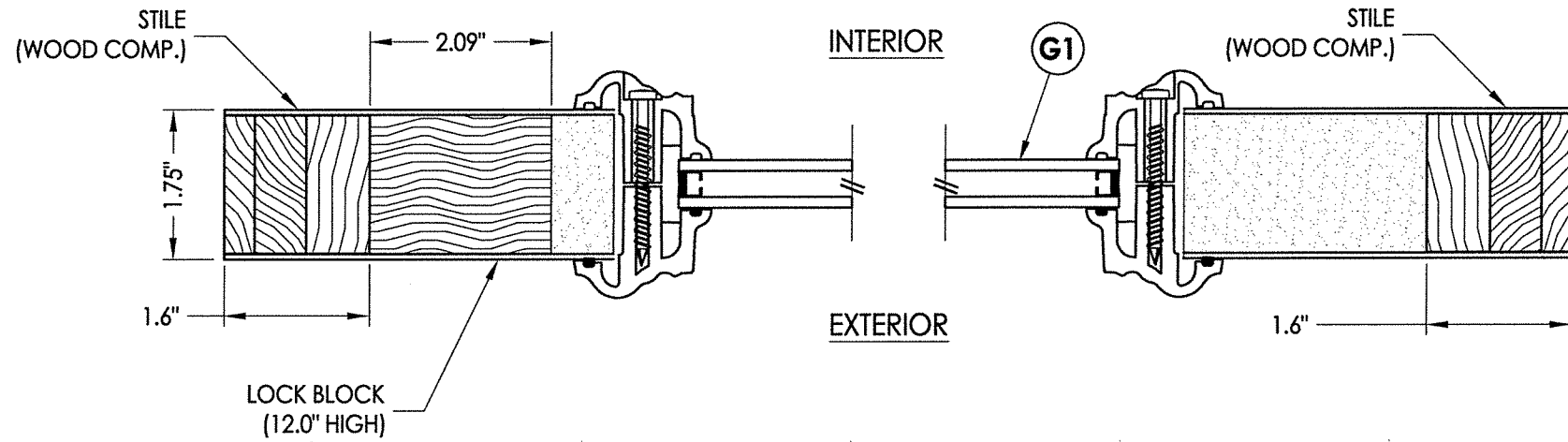

1
2 HORIZONTAL CROSS SECTION

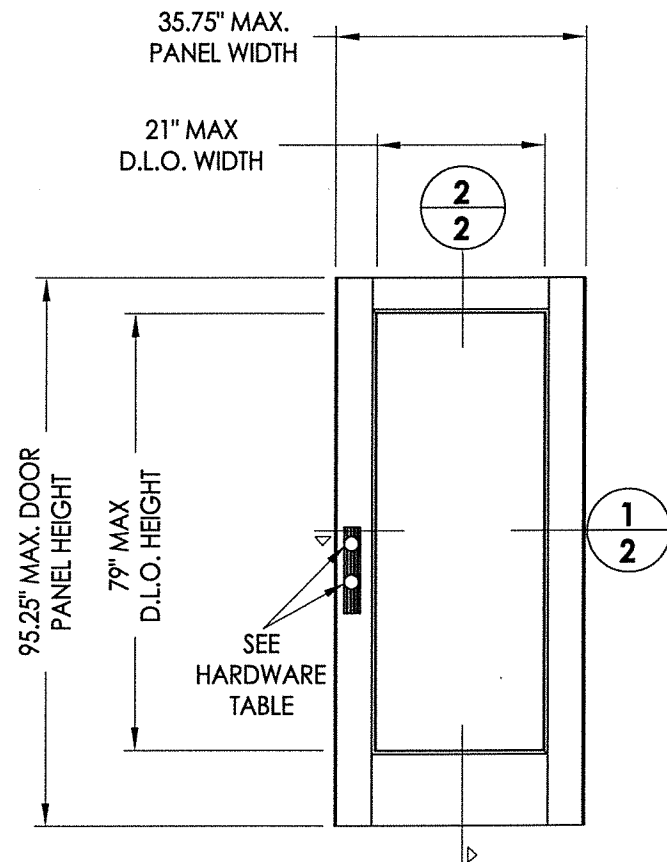

MASONITE
Insert glazed
(fiberglass)

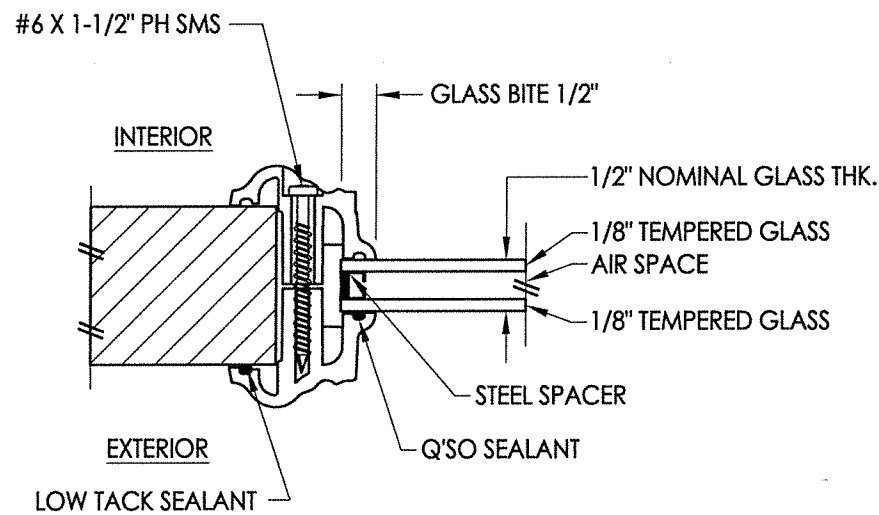

G1 GLAZING DETAIL
Lip Lite Insert Glazing

HARDWARE TABLE	
MANUFACTURER	MODEL
KWIKSET	LATCH: KWIKSET SIGNATURE SERIES (991) DEADBOLT: KWIKSET SIGNATURE SERIES (980/985)

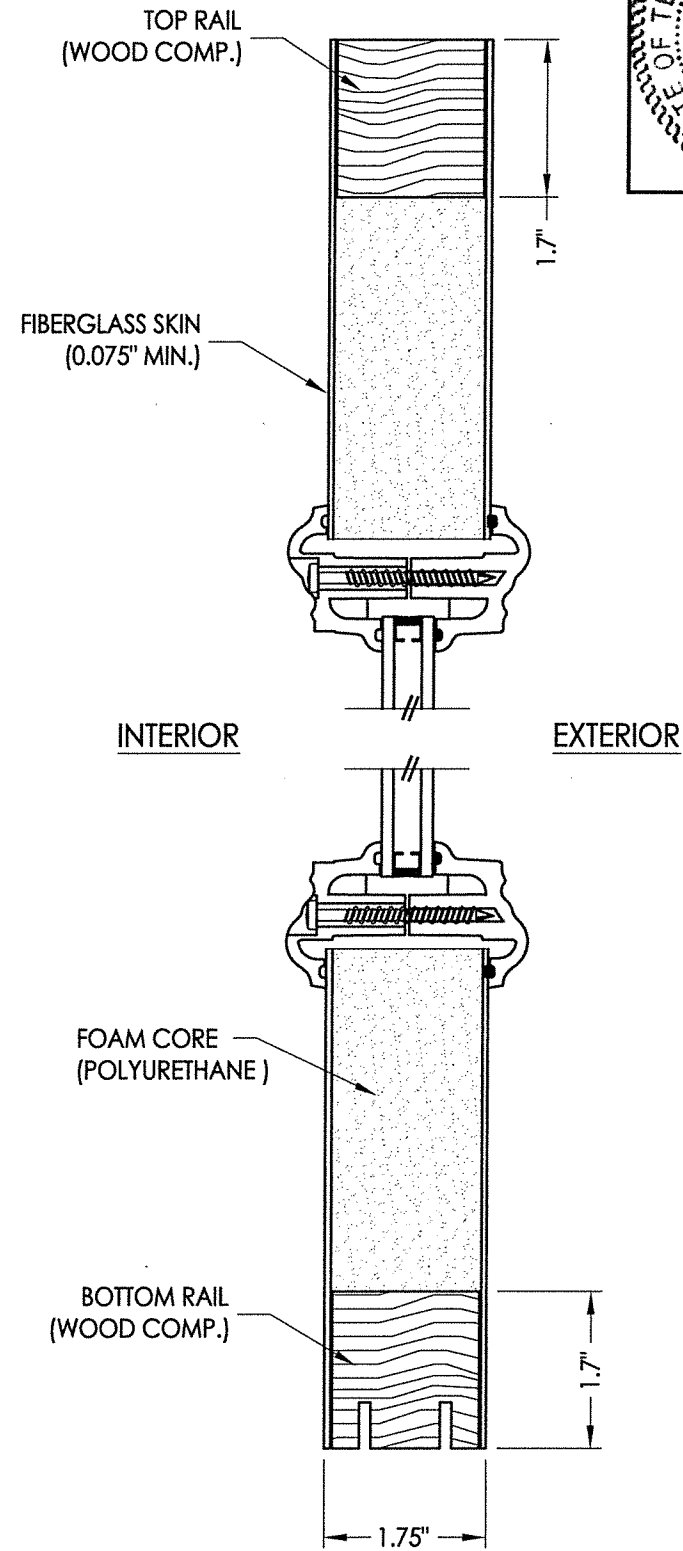

2
2 VERTICAL CROSS SECTION

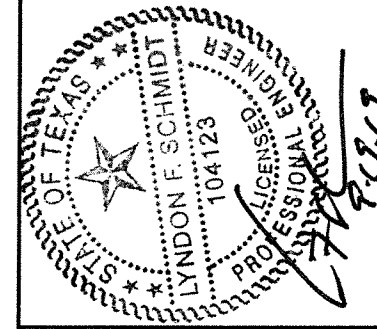

Documents Prepared By: Lyndon F. Schmidt, P.E.
TEXAS P.E. #104123

RW BUILDING CONSULTANTS, INC.
P.O. Box 230 Vairico FL, 33595
Phone No.: 813.659.9197

TEXAS BOARD OF PROFESSIONAL ENGINEERS
CERTIFICATE OF REGISTRATION # F-11852

PRODUCT: ENDURA
PART OR ASSEMBLY: DOOR PANEL DETAILS (LIP LITE INSERT GLAZING)

NO.	DATE	REVISIONS
5	9/16/19	ADD "FusionFrame" OPTION & UPDATE TO 2018 IBC/IRC CODE
4	11/07/18	REVISED TO INSERT GLAZED ONLY
3	10/25/16	ADDED THRESHOLDS
2	5/5/15	ADD NEW ASTRAGAL PIN CAPTURE
1	11/26/13	ADDED ARTICULATING SILL
		BY

DATE: 7/03/12
SCALE: N.T.S.
DWG. BY: JK
CHK. BY: LFS
DRAWING NO.: TX-4165
SHEET 5 OF 8

R:\Clients\Endura PERMANENT\B - Texas Dept of Ins\TDI - DR-570 (Exp. 11-1-17)\C - Drawings\REV 2018 Insert Glazed\TX-4164-65.dwg, 6.2

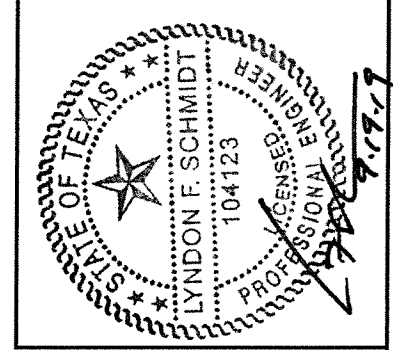
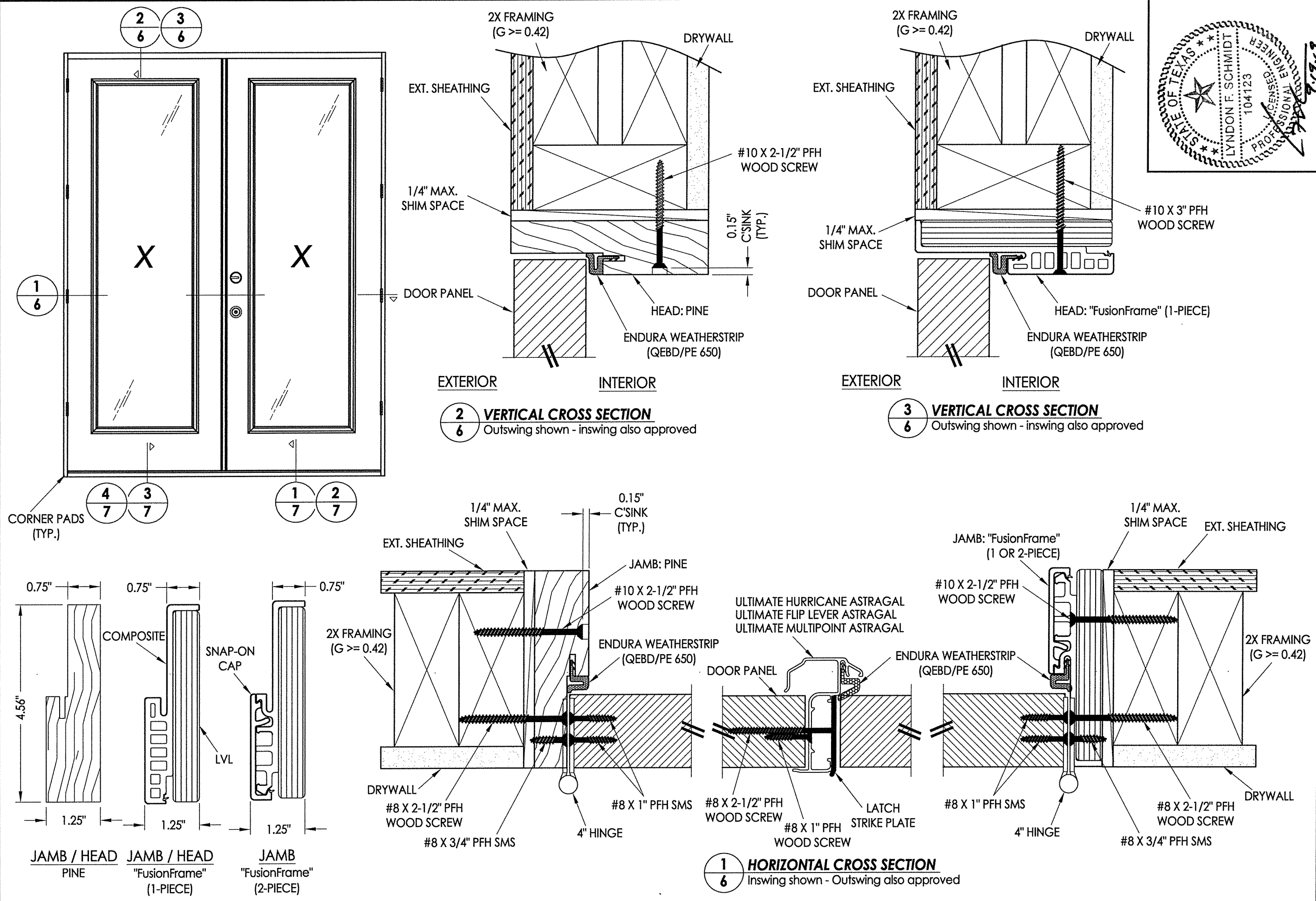

Documents Prepared By: Lyndon F. Schmidt, P.E.
 TEXAS P.E. #104123
RW BUILDING CONSULTANTS, INC.
 P.O. Box 230 Valrico FL 33595
 Phone No.: 813.659.9197
 TEXAS BOARD OF PROFESSIONAL ENGINEERS
 CERTIFICATE OF REGISTRATION # F-11852

PRODUCT: ENDURA
 PART OR ASSEMBLY: HORIZONTAL & VERTICAL CROSS SECTIONS

NO.	DATE	REVISIONS
5	9/16/19	ADD "FusionFrame" OPTION & UPDATE TO 2018 IBC/IRC CODE
4	11/07/18	REVISED TO INSERT GLAZED ONLY
3	10/25/16	ADDED THRESHOLDS
2	5/5/15	ADD NEW ASTRAGAL PIN CAPTURE
1	11/26/13	ADDED ARTICULATING SILL

DATE: 7/03/12
 SCALE: N.T.S.
 DWG. BY: JK
 CHK. BY: LFS
 DRAWING NO.: TX-4165
 SHEET 6 OF 8

© 2012 R.W. BUILDING CONSULTANTS INC.

R:\Clients\Endura PERMANENT\B - Texas Dept of Ins\TDI - DR-570 (Exp. 11-1-17)\C - Drawings\REV 2018 Insert Glazed\TX-4164-65.dwg, 7.2

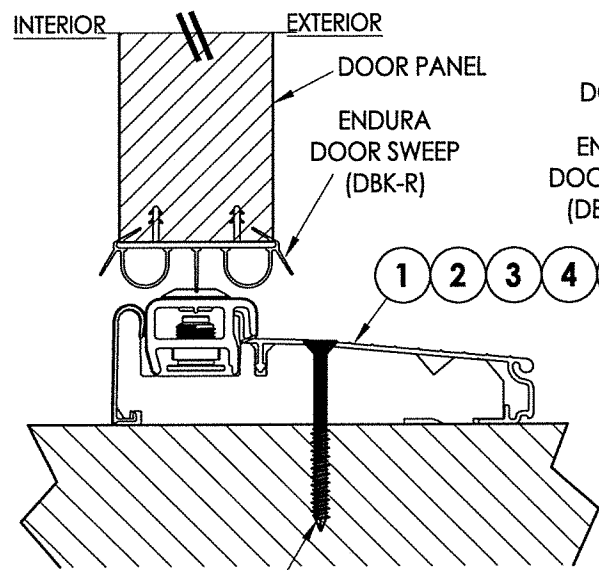

#10 X 2.5" PFH WOOD SCREW OR
1/4" X 2-3/4" ELCO OR ITW CONCRETE SCREW

1 VERTICAL CROSS SECTION
7 Inswing Adjustable Threshold

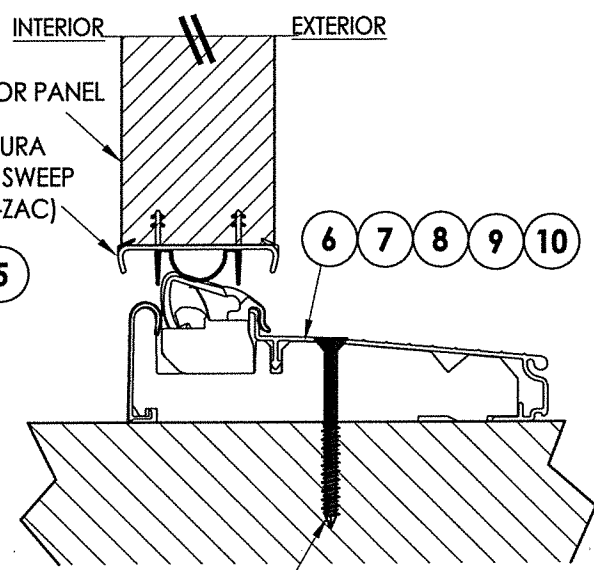

#10 X 2.5" PFH WOOD SCREW OR
1/4" X 2-3/4" ELCO OR ITW CONCRETE SCREW

2 VERTICAL CROSS SECTION
7 Inswing Articulating Threshold
w/ Pin Capture

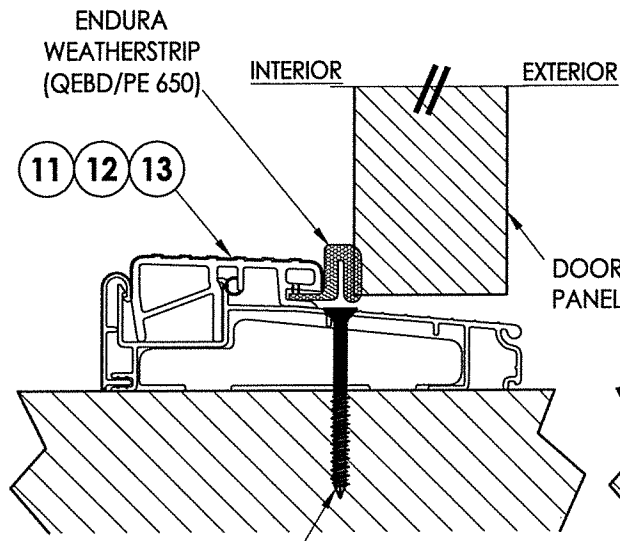

#10 X 2.5" PFH WOOD SCREW OR
1/4" X 2-3/4" ELCO OR ITW CONCRETE SCREW

3 VERTICAL CROSS SECTION
7 Outswing Bump Threshold

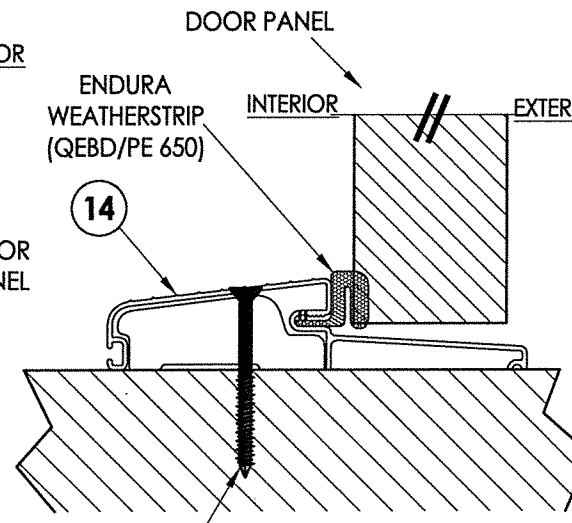

#10 X 2.5" PFH WOOD SCREW OR
1/4" X 2-3/4" ELCO OR ITW CONCRETE SCREW

4 VERTICAL CROSS SECTION
7 Outswing Bump Threshold

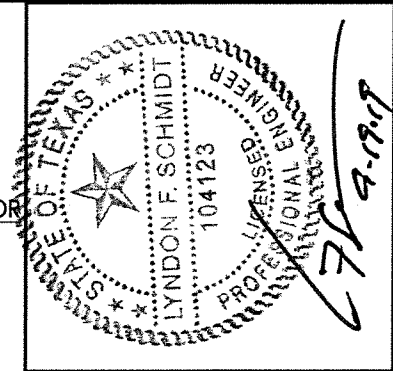

Documents Prepared By: Lyndon F. Schmidt, P.E.
TEXAS P.E. #104123

RW BUILDING CONSULTANTS, INC.
P.O. Box 230 Valrico FL 33595
Phone No.: 813.659.9197
TEXAS BOARD OF PROFESSIONAL ENGINEERS
CERTIFICATE OF REGISTRATION # F-11852

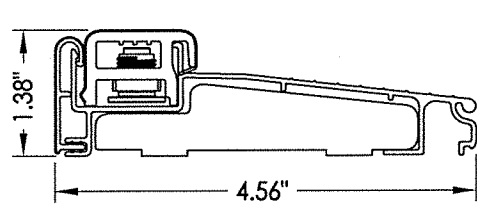

1 INSWING ADJUSTABLE THRESHOLD
ZAIL4565

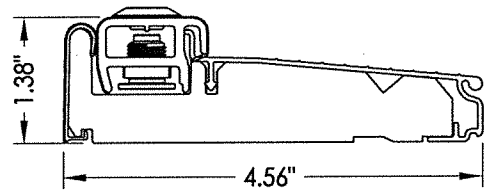

2 INSWING ADJUSTABLE THRESHOLD
ZAI4565FN

MAX. DESIGN PRESSURE = +40/-45 PSF

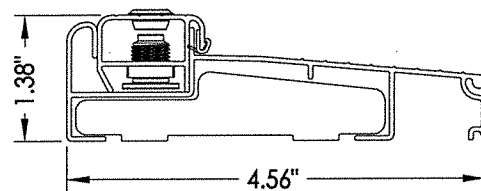

3 INSWING ADJUSTABLE THRESHOLD
ZAILAA4565

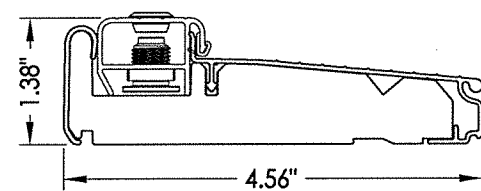

4 INSWING ADJUSTABLE THRESHOLD
ZAIAA4565FN

MAX. DESIGN PRESSURE = +40/-45 PSF

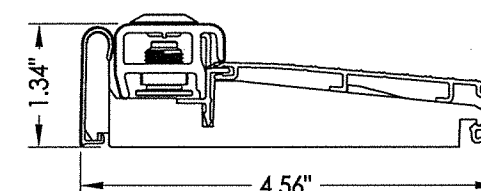

5 INSWING ADJUSTABLE THRESHOLD
ZAI4565RDS

MAX. DESIGN PRESSURE = ±40 PSF

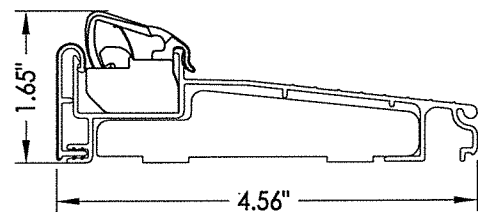

6 INSWING ARTICULATING THRESHOLD
ZACL4565

MAX. DESIGN PRESSURE = +40/-45 PSF

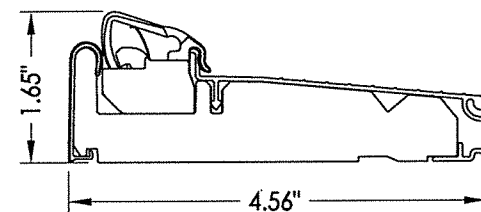

7 INSWING ARTICULATING THRESHOLD
ZAC4565FN

MAX. DESIGN PRESSURE = +40/-45 PSF

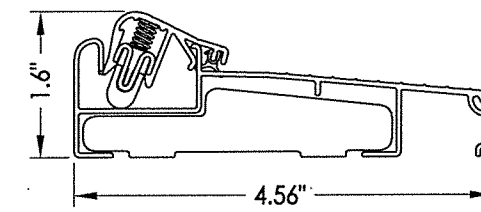

8 INSWING ARTICULATING THRESHOLD
ZACLAA4565

MAX. DESIGN PRESSURE = +40/-45 PSF

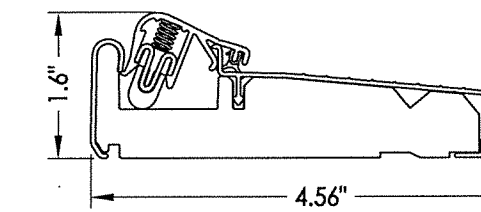

9 INSWING ARTICULATING THRESHOLD
ZACAA4565FN

MAX. DESIGN PRESSURE = +40/-45 PSF

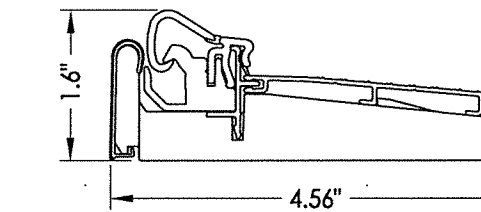

10 INSWING ARTICULATING THRESHOLD
ZAC4565RDS

MAX. DESIGN PRESSURE = ±35 PSF

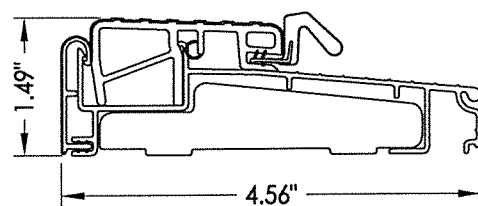

11 OUTSWING THRESHOLD
ZOBL4565

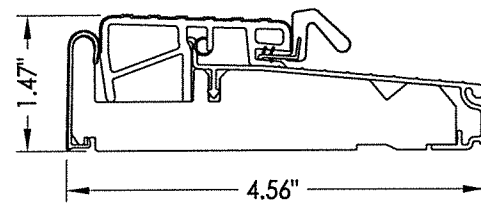

12 OUTSWING THRESHOLD
ZOB4565FN

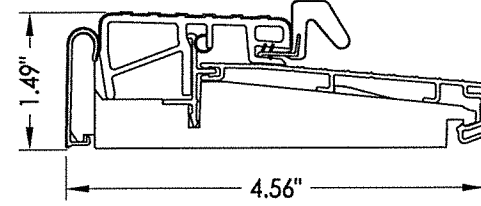

13 OUTSWING THRESHOLD
ZOB4565RDS

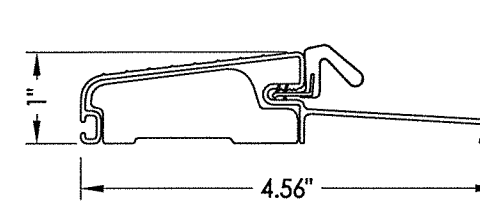

14 OUTSWING THRESHOLD
FOB4566

ENDURA
PRODUCT:
PART OR ASSEMBLY:
VERTICAL CROSS SECTIONS

NO.	DATE	REVISIONS	BY
5	9/16/19	ADD "FusionFrame" OPTION & UPDATE TO 2018 IBC/IRC CODE	LFS
4	11/07/18	REVISED TO INSERT GLAZED ONLY	LFS
3	10/25/16	ADDED THRESHOLDS	LFS
2	5/5/15	ADD NEW ASTRAGAL PIN CAPTURE	LFS
1	11/26/13	ADDED ARTICULATING SILL	LFS

DATE: 7/03/12
SCALE: N.T.S.
DWG. BY: JK
CHK. BY: LFS
DRAWING NO.: TX-4165
SHEET 7 OF 8

© 2012 R.W. BUILDING CONSULTANTS INC.

R:\Clients\Endura PERMANENT\B - Texas Dept of Ins\TDI - DR-570 (Exp. 11-1-17)\C - Drawings\REV 2018 Insert Glazed\TX-4164-65.dwg, 8.2

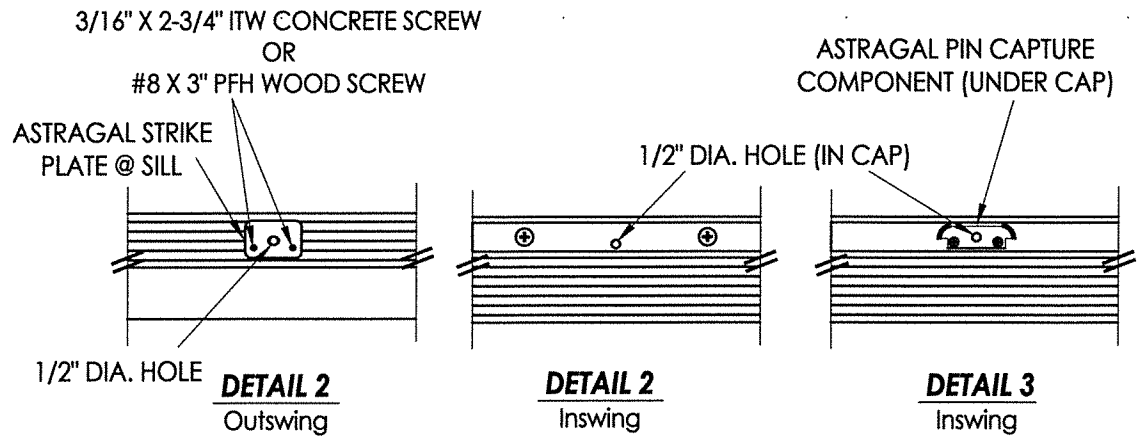
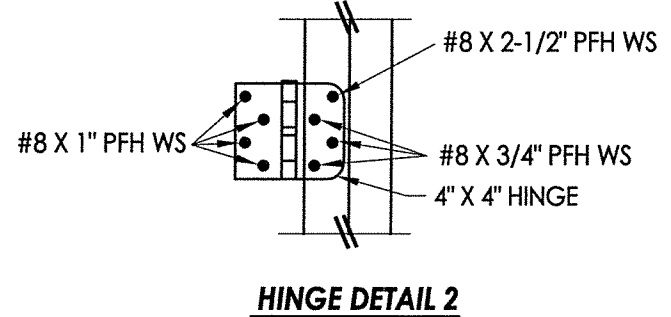
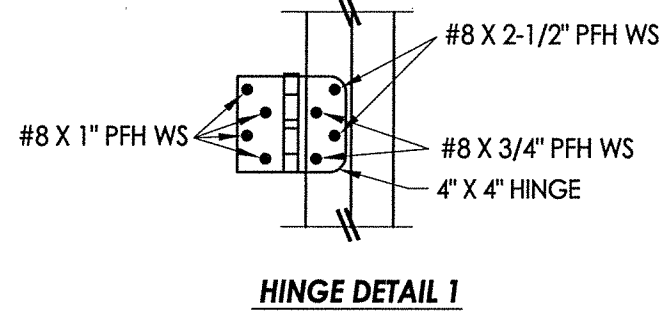
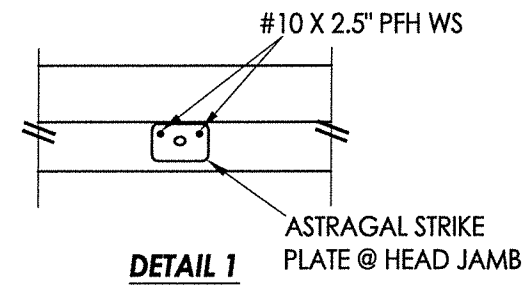
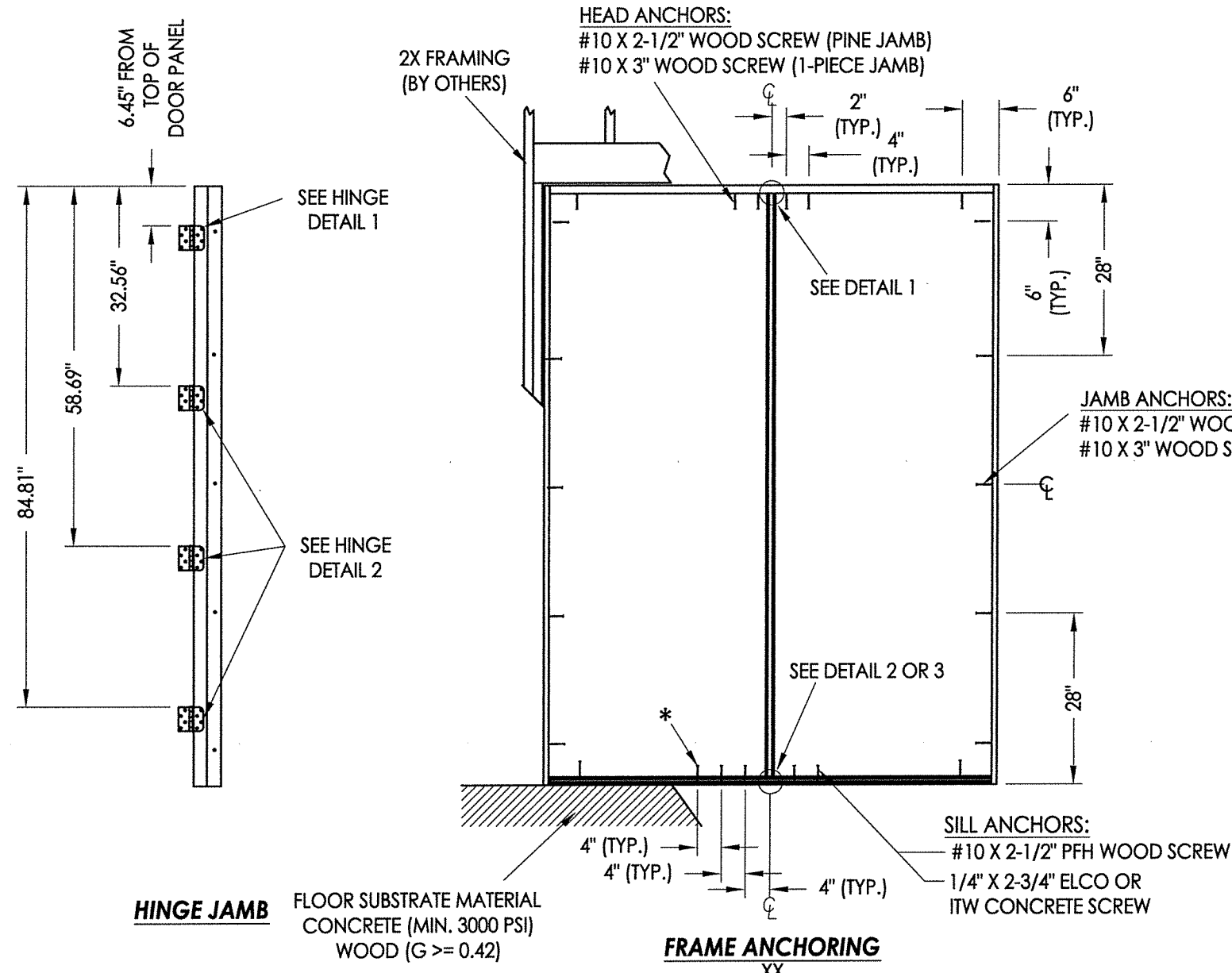

JAMB NOTES:
 THE PINE OR "FusionFrame" 1-PIECE JAMB MAY BE INSTALLED @ THE HEAD OR SIDE JAMB.
 THE FusionFrame" 2-PIECE JAMB MAY BE INSTALLED @ THE SIDE JAMBS ONLY.

- CONCRETE ANCHOR NOTES:**
- Concrete anchor locations at the corners may be adjusted to maintain the min. edge distance to mortar joints.
 - Concrete anchor locations noted as "MAX. ON CENTER" must be adjusted to maintain the min. edge distance to mortar joints, additional concrete anchors may be required to ensure the "MAX. ON CENTER" dimension are not exceeded.
 - Concrete anchor table:

ANCHOR TYPE	ANCHOR SIZE	MIN. EMBEDMENT	MIN. CLEARANCE TO MASONRY EDGE	MIN. CLEARANCE TO ADJACENT ANCHOR
ITW TAPCON®	3/16"	1-3/4"	3"	1-1/2"
ITW TAPCON®	1/4"	1-3/4"	1-1/2"	4"
ELCO ULTRACON®	1/4"	1-3/4"	1"	4"

WOOD SCREW INSTALLATION NOTES:

- Maintain a minimum 5/8" edge distance, 1" end distance, & 1" o.c. spacing of wood screws to prevent the splitting of wood.

*** NOTE: THIS ANCHOR REQUIRED FOR D.P. > 45 PSF.**

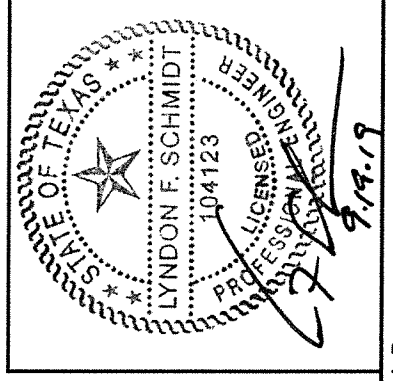

Documents Prepared By: Lyndon F. Schmidt, P.E.
 TEXAS P.E. #104123

RW BUILDING CONSULTANTS, INC.
 P.O. Box 230 Valrico FL 33595
 Phone No.: 813.659.9197

TEXAS BOARD OF PROFESSIONAL ENGINEERS
 CERTIFICATE OF REGISTRATION # F-11852

PRODUCT: ENDURA

PART OR ASSEMBLY: FRAME ANCHORING

NO	DATE	BY	REVISIONS
5	9/16/19	LFS	ADD "FusionFrame" OPTION & UPDATE TO 2018 IBC/IRC CODE
4	11/07/18	LFS	REVISED TO INSERT GLAZED ONLY THRESHOLDS
3	10/25/16	LFS	ADDED THRESHOLDS
2	5/5/15	LFS	ADD NEW ASTRAGAL PIN CAPTURE
1	11/26/13	LFS	ADDED ARTICULATING SILL

DATE: 7/03/12
 SCALE: N.T.S.
 DWG. BY: JK
 CHK. BY: LFS
 DRAWING NO.: TX-4165
 SHEET 8 OF 8

© 2012 R.W. BUILDING CONSULTANTS INC.