



TRINITY GLASS
INTERNATIONAL

33615 1st Way S, Federal Way, WA 98003

3'0 X 6'8
OPAQUE PREMIUM FIBERGLASS
SINGLE DOOR w/ SIDELITES (CHS)
INSWING / OUTSWING
"IMPACT" DOOR w/ "NON-IMPACT" SIDELITES

EVALUATED FOR USE IN THE STATE OF TEXAS

The Fiberglass Door system described herein complies with the 2018 International Residential Code (IRC), Sections R301 & R609 and the 2018 International Building Code (IBC), Sections 1404.13, 1609, 1709.5, 2403 and 2404 subject to the following conditions:

1. Anchors shall be as listed and spaced as shown in the details. Anchor embedment to base material shall be beyond wall dressing or stucco.
2. When used in wind borne debris regions, the opaque door panel has been tested and evaluated as an impact resistant product and does not require the use of an approved impact resistant covering. The sidelite must be protected with an impact resistant covering that complies with Sections R301.2.1.2 and 1609.1.2. This opaque door meets missile level "D" as defined in ASTM E 1996.
3. Allowable design pressure requirements must be equal to or less than the design pressure rating shown in the design pressure chart, sheet 1 of this drawing.
4. Conditions not covered by this drawing are subject to further engineering analysis.

TABLE OF CONTENTS

SHEET #	DESCRIPTION
1	Typical elevations, design pressures & general notes
2	Door panel construction details
3	Sidelite panel construction details & glazing details
4	Horizontal cross sections
5	Vertical cross sections
6	Vertical cross sections
7	Frame anchoring
8	Components
9	Bill of materials & components

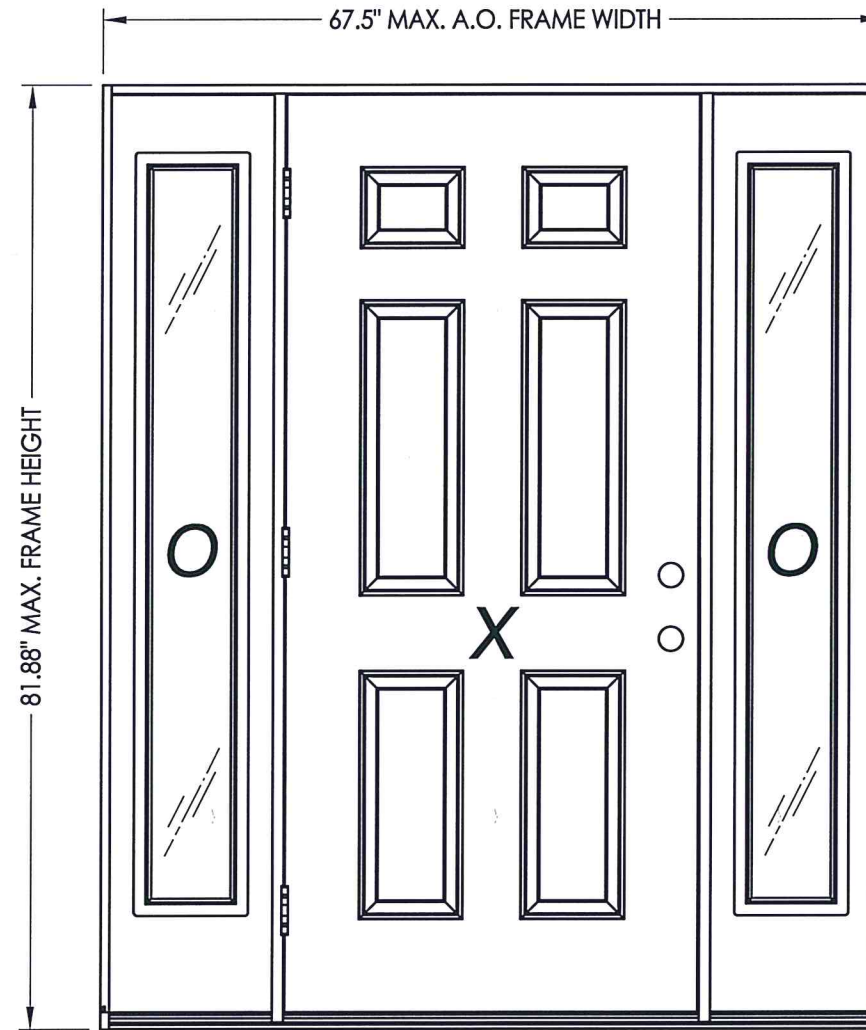

CONTINUOUS HEADER AND SILL

SWING	MAX. FRAME DIMENSION	GLASS TYPE	DESIGN PRESSURE (PSF)	
			POSITIVE	NEGATIVE
INSWING	67.5" x 81.88"	G1	+60.0	-70.0
OUTSWING	67.5" x 80.75"		+60.0	-60.0

Refer to Table (Sheet 4) for Passage Lock Rating Limitations



Documents Prepared By: Lyndon F. Schmidt, P.E.
TEXAS P.E. #104123

RW BUILDING CONSULTANTS, INC.
P.O. Box 230 Valrico FL, 33595
Phone No.: 813.659.9197

TEXAS BOARD OF PROFESSIONAL ENGINEERS
CERTIFICATE OF REGISTRATION # F-11852

PRODUCT:	TRINITY GLASS INT'L 6'8 PREMIUM OPAQUE
PART OR ASSEMBLY:	TYPICAL ELEVATION, DESIGN PRESSURES & GENERAL NOTES
DATE:	8/25/05
SCALE:	N.T.S.
DWG. BY:	EW
CHK. BY:	LFS
DRAWING NO.:	TX-590
SHEET	1 OF 9

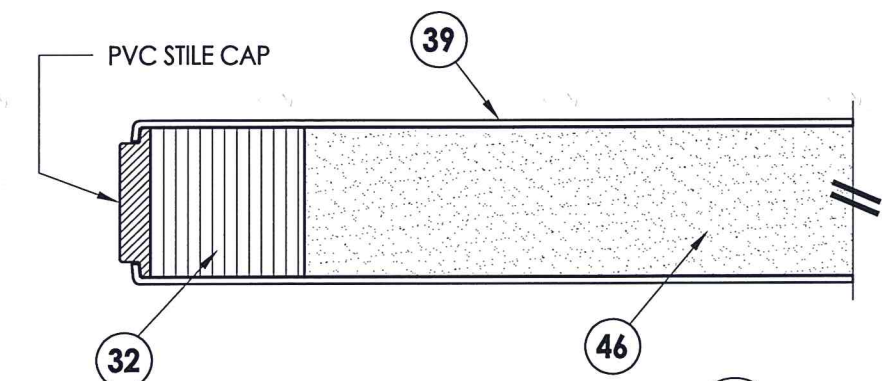

1
2 HORIZONTAL CROSS SECTION

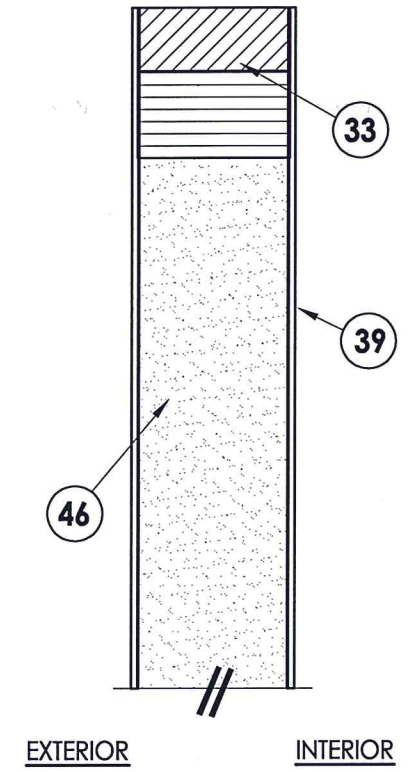
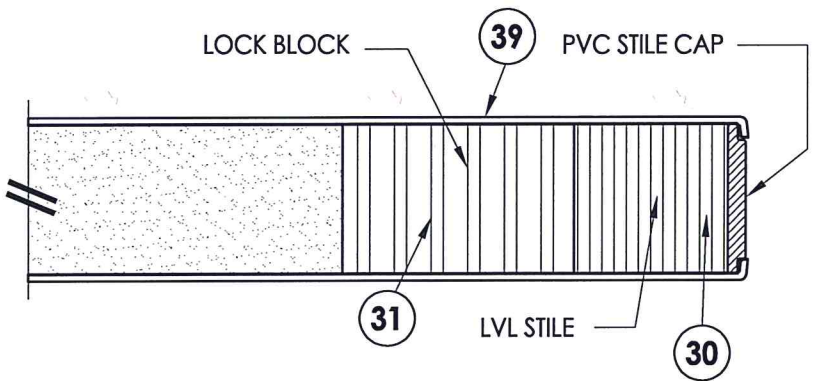

2
2 VERTICAL CROSS SECTION

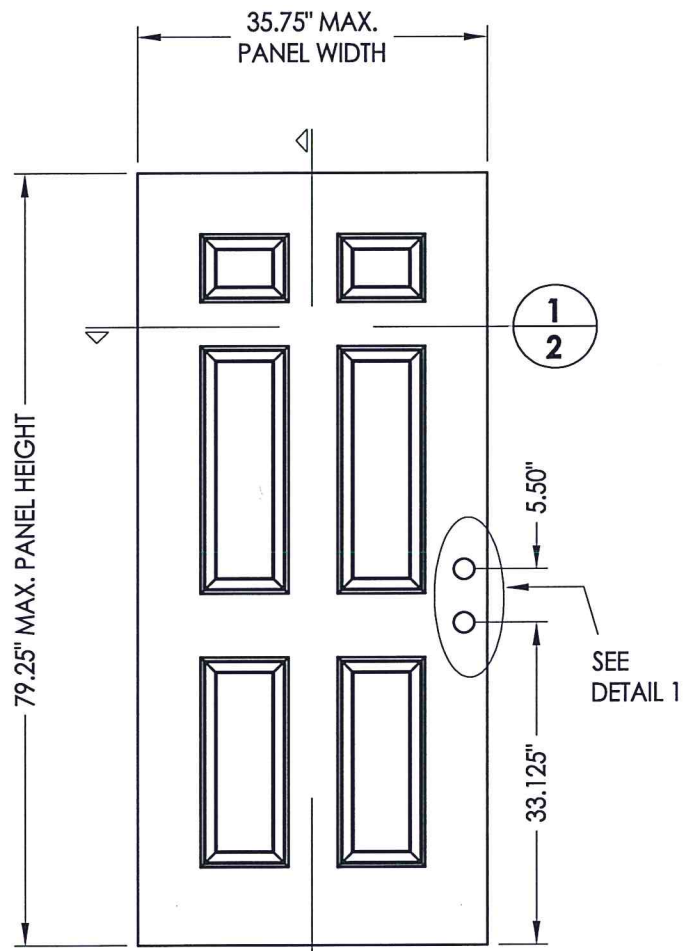

7 PREMIUM OPAQUE DOOR
"IMPACT"

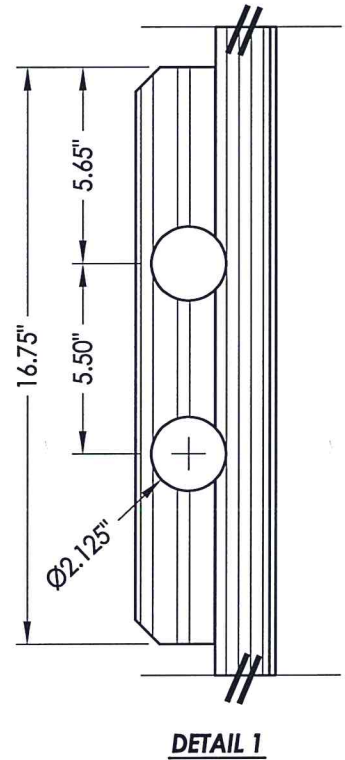

DETAIL 1

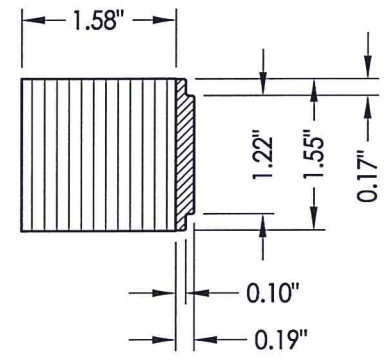

30 LATCH STILE

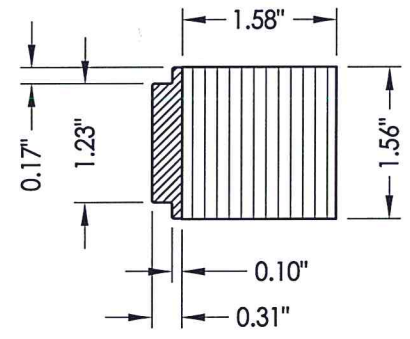

32 HINGE STILE

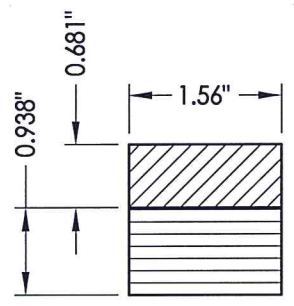

33 TOP RAIL

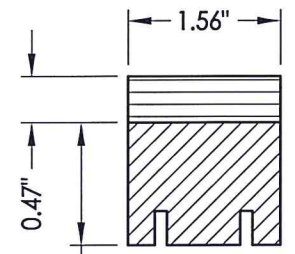

34 BOTTOM RAIL

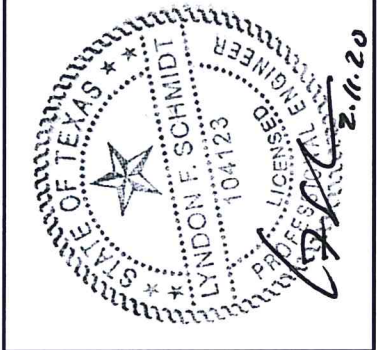

Documents Prepared By: Lyndon F. Schmidt, P.E.
TEXAS P.E. #104123

RW BUILDING CONSULTANTS, INC.
P.O. Box 230 Valrico FL 33595
Phone No.: 813.659.9197

TEXAS BOARD OF PROFESSIONAL ENGINEERS
CERTIFICATE OF REGISTRATION # F-11852

PRODUCT: TRINITY GLASS INT'L
6'8 PREMIUM OPAQUE

PART OR ASSEMBLY: DOOR PANEL
CONSTRUCTION DETAILS

REVISIONS	
NO.	DATE
3	2/10/20 UPDATE TO 2018 IBC/IRC
2	7/27/09 TDI PRODUCT EVALUATION UPDATE
1	6/28/06 REVISED LOCKSET NOMENCLATURE
	BY

DATE: 8/25/05
SCALE: N.T.S.
DWG. BY: EW
CHK. BY: LFS
DRAWING NO.: TX-590
SHEET 2 OF 9

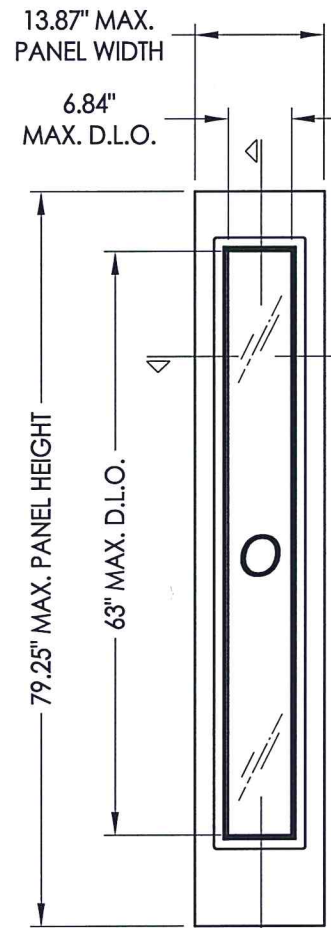

66 FIBERGLASS SIDELITE
"NON-IMPACT"

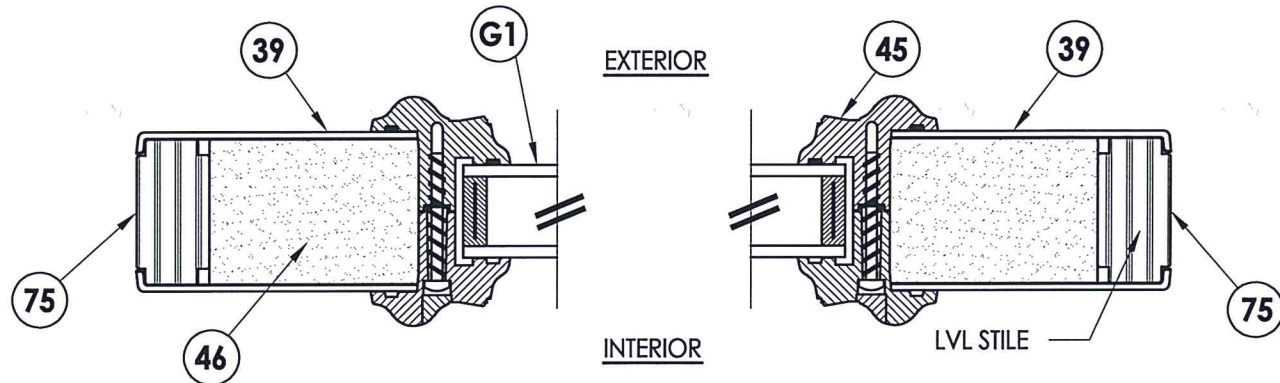

1/3 HORIZONTAL CROSS SECTION

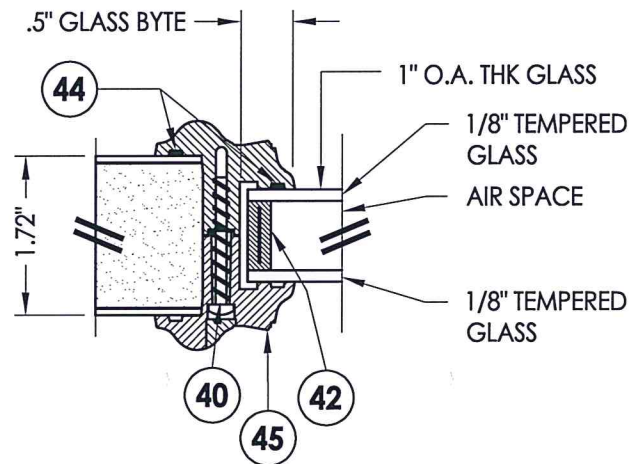

G1 GLAZING DETAIL

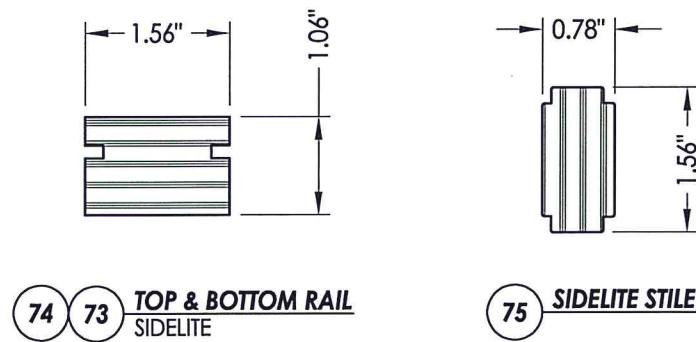

74 73 TOP & BOTTOM RAIL
SIDELITE

75 SIDELITE STILE

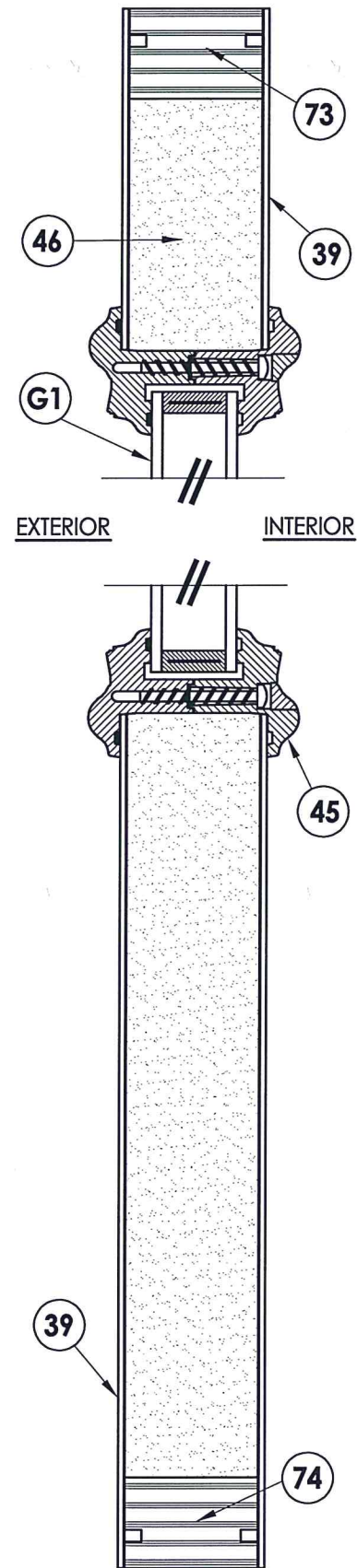

2/3 VERTICAL CROSS SECTION

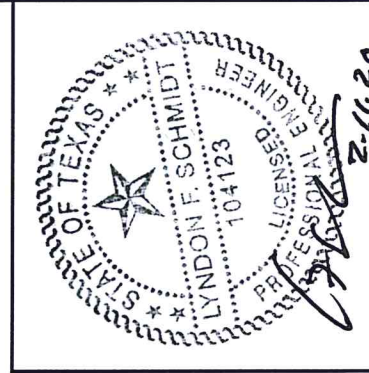

Documents Prepared By: Lyndon F. Schmidt, P.E.
TEXAS P.E. #104123

RW BUILDING CONSULTANTS, INC.
P.O. Box 230 Valrico FL 33595
Phone No.: 813.659.9197
TEXAS BOARD OF PROFESSIONAL ENGINEERS
CERTIFICATE OF REGISTRATION # F-11852

PRODUCT: TRINITY GLASS INT'L
6'8 PREMIUM OPAQUE
PART OR ASSEMBLY: SIDELITE PANEL CONSTRUCTION
DETAILS AND GLAZING DETAILS

NO.	DATE	REVISIONS
3	2/10/20	UPDATE TO 2018 IBC/IRC
2	7/27/09	TDI PRODUCT EVALUATION UPDATE
1	6/28/06	REVISED LOCKSET NOMENCLATURE

DATE: 8/25/05
SCALE: N.T.S.
DWG. BY: EW
CHK. BY: LFS
DRAWING NO.: TX-590
SHEET 3 OF 9

NOTE:

- Sidelite ass'y fastener: 6" from each end and 4 more screws equally spaced between (6 screws total per jamb).

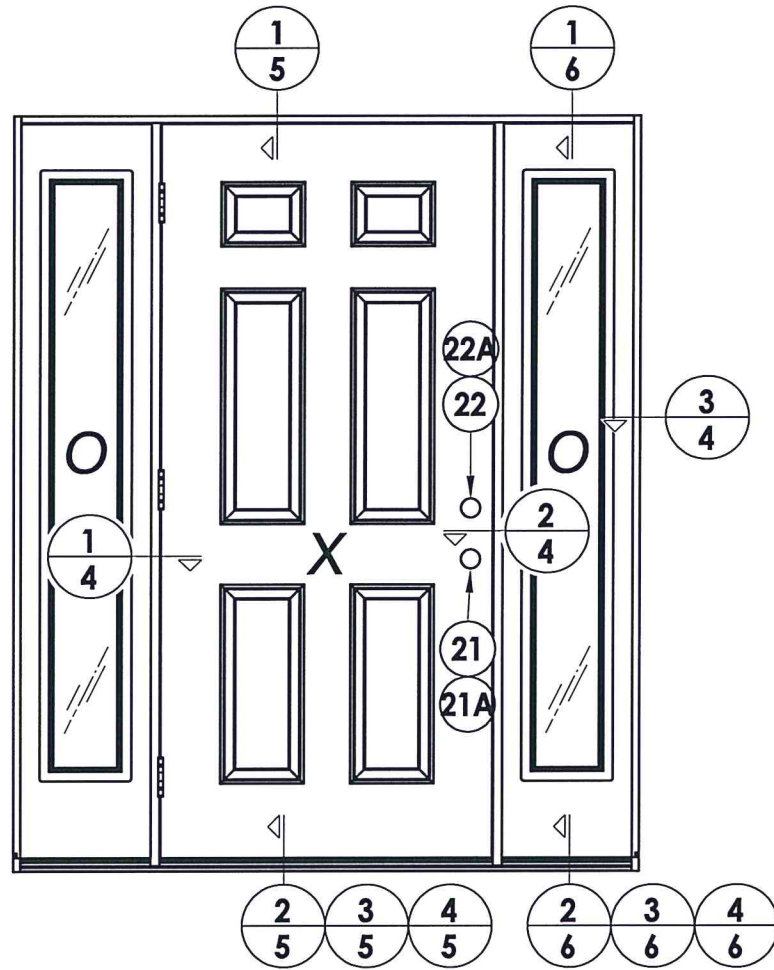

LOCK & DEADBOLT RATINGS CHART				
MANUFACTURER	MODEL	ITEM #	MAX. DESIGN PRESSURE (PSF)	
			POSITIVE	NEGATIVE
KWIKSET	LOCK: 740	21	+60.0	-70.0
	DEADBOLT: 780	22		
KWIKSET	LOCK: COMBO 660	21	+60.0	-65.0
	DEADBOLT: COMBO 660	22		
SCHLAGE	LOCK: MAX. SECURITY	21	+55.0	-55.0
	DEADBOLT: MAX. SECURITY	22		



Documents Prepared By: Lyndon F. Schmidt, P.E.
 TEXAS P.E. #104123

RW BUILDING CONSULTANTS, INC.
 P.O. Box 230 Valrico FL, 33595
 Phone No.: 813.659.9197

TEXAS BOARD OF PROFESSIONAL ENGINEERS
 CERTIFICATE OF REGISTRATION # F-11852

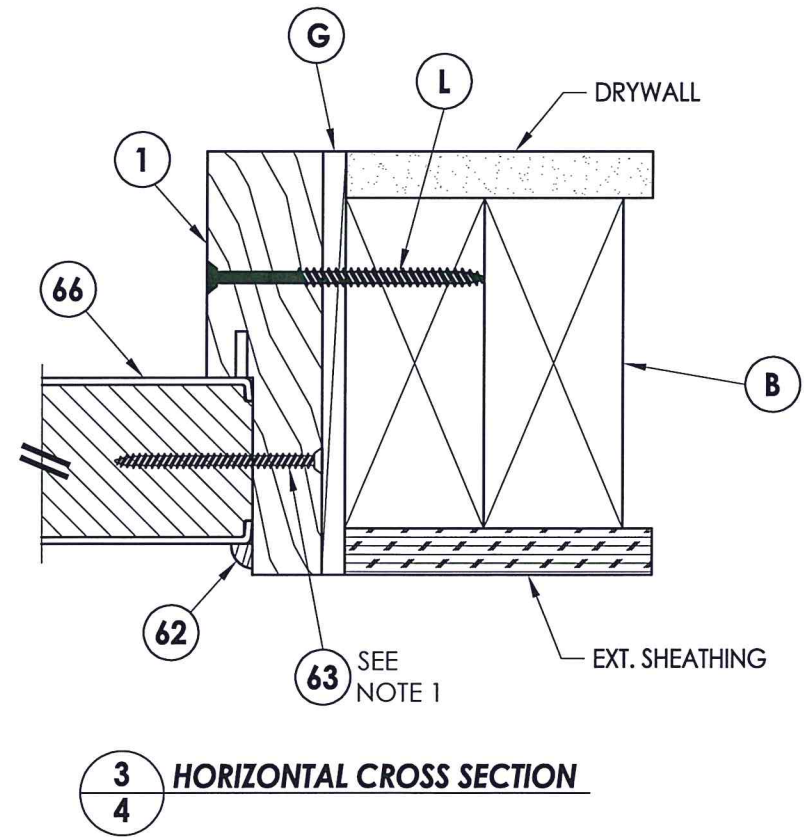
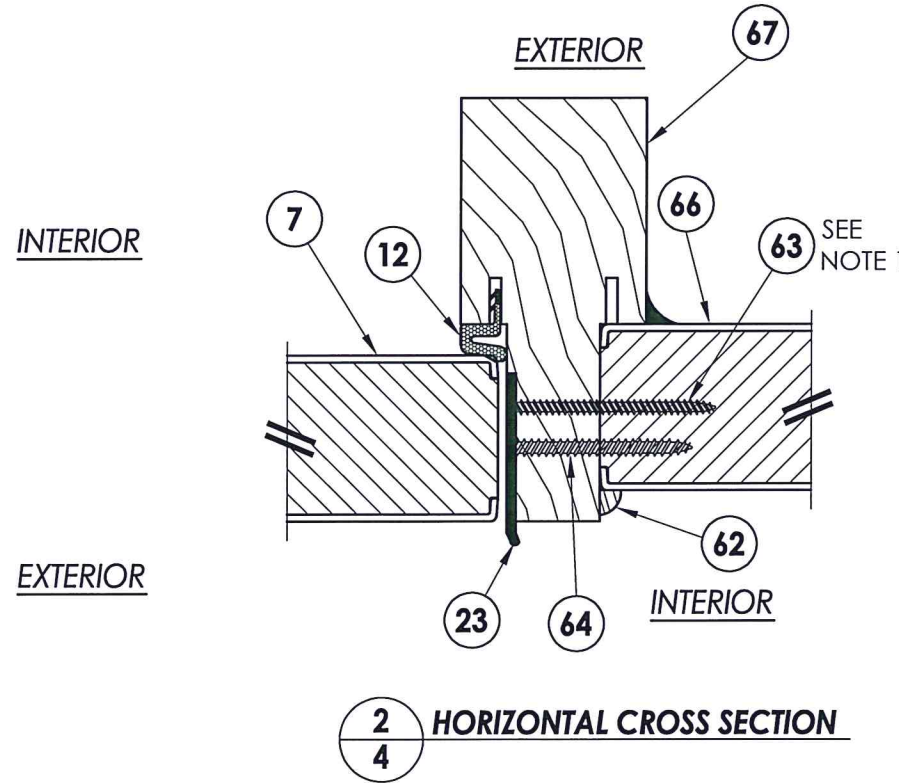
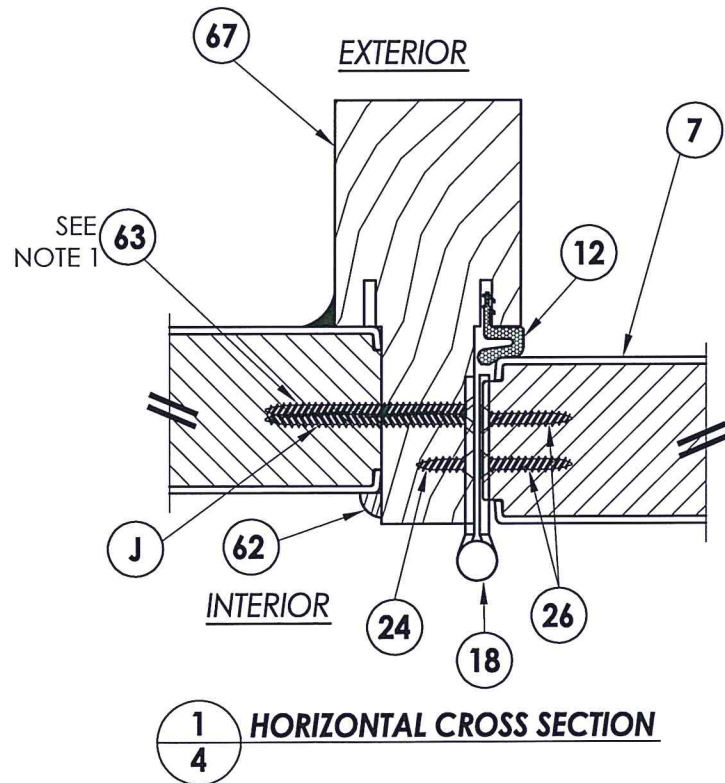

PRODUCT: TRINITY GLASS INT'L 6'8 PREMIUM OPAQUE		PART OR ASSEMBLY: HORIZONTAL CROSS SECTION	
NO.	DATE	BY	REVISIONS
3	2/10/20	EW	UPDATE TO 2018 IBC/IRC
2	7/27/09	AL	TDI PRODUCT EVALUATION UPDATE
1	6/28/06	EW	REVISED LOCKSET NOMENCLATURE

DATE: 8/25/05
 SCALE: N.T.S.
 DWG. BY: EW
 CHK. BY: LFS
 DRAWING NO.: TX-590
 SHEET 4 of 9

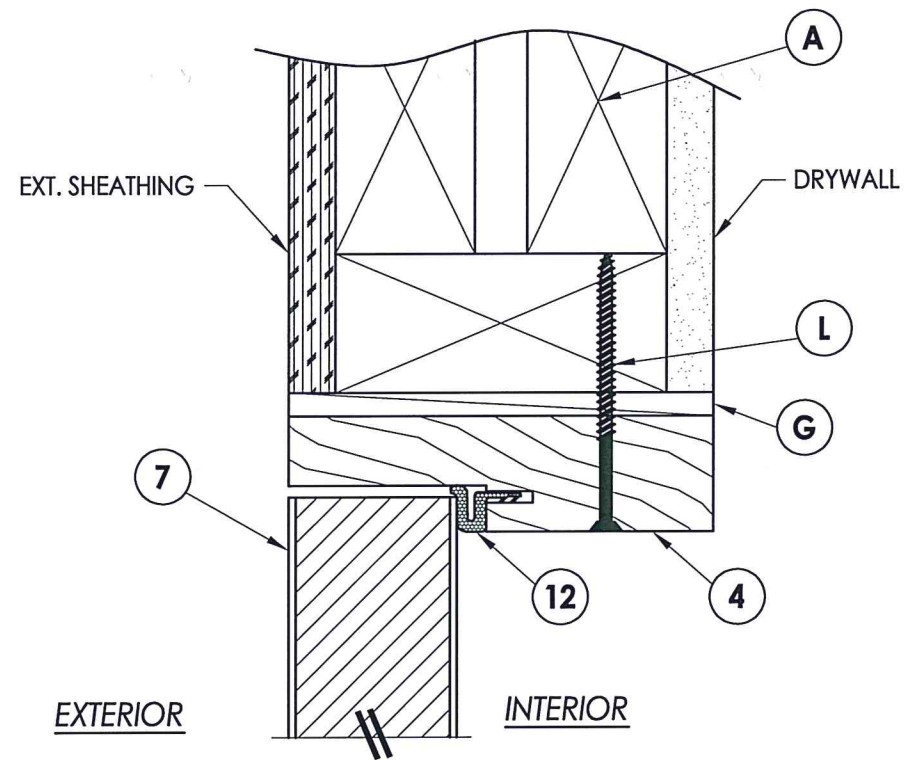

1 VERTICAL CROSS SECTION
5 Outswing shown
 Inswing also approved

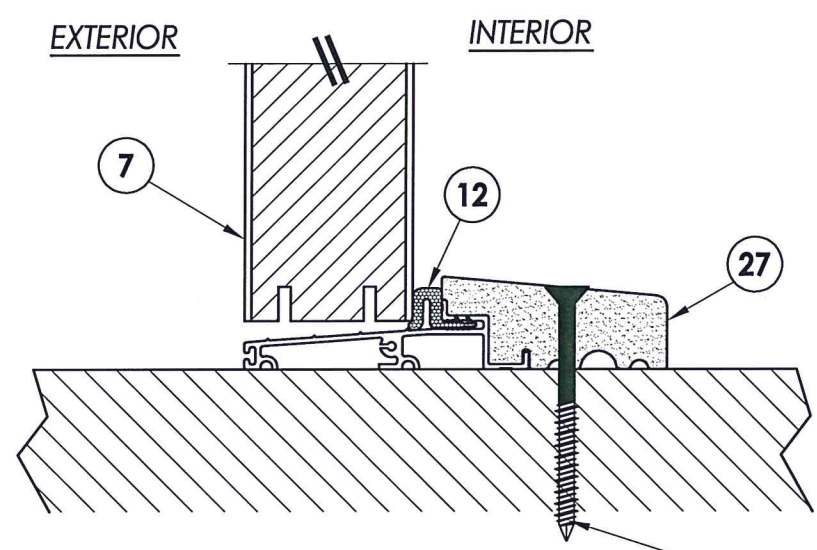

2 VERTICAL CROSS SECTION
5 Outswing configuration

L WOOD
P CONCRETE

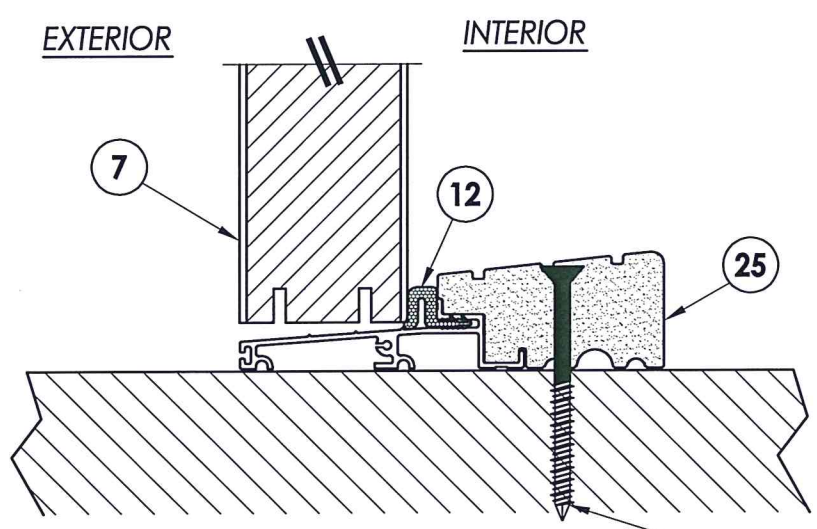

3 VERTICAL CROSS SECTION
5 Outswing configuration

L WOOD
P CONCRETE

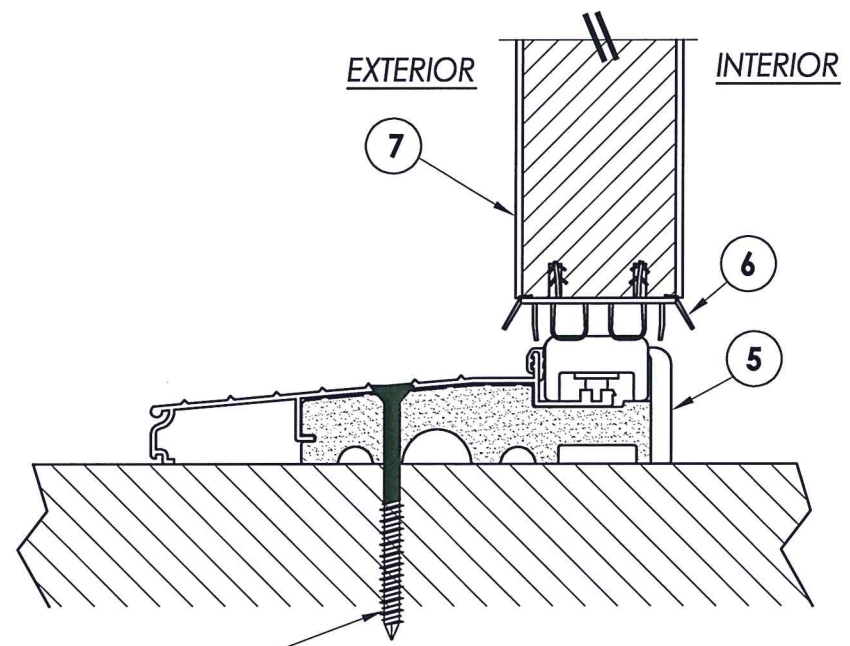

4 VERTICAL CROSS SECTION
5 Inswing configuration

WOOD **L**
 CONCRETE **P**

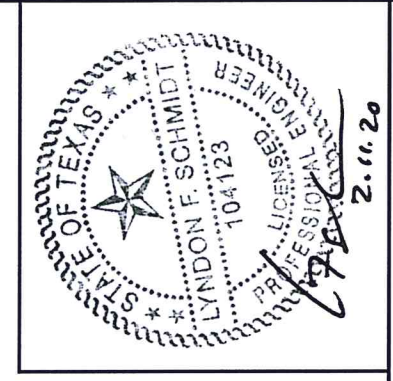

Documents Prepared By: Lyndon F. Schmidt, P.E.
 TEXAS P.E. #104123

RW BUILDING CONSULTANTS, INC.
 P.O. Box 230 Valrico FL 33595
 Phone No.: 813.659.9197

TEXAS BOARD OF PROFESSIONAL ENGINEERS
 CERTIFICATE OF REGISTRATION # F-11852

PRODUCT: TRINITY GLASS INT'L
 6.8 PREMIUM OPAQUE

PART OR ASSEMBLY: VERTICAL CROSS SECTIONS

NO.	DATE	REVISIONS
3	2/10/20	UPDATE TO 2018 IBC/IRC
2	7/27/09	TDI PRODUCT EVALUATION UPDATE
1	6/28/06	REVISED LOCKSET NOMENCLATURE
		BY

DATE: 8/25/05
 SCALE: N.T.S.
 DWG. BY: EW
 CHK. BY: LFS
 DRAWING NO.: TX-590
 SHEET 5 OF 9

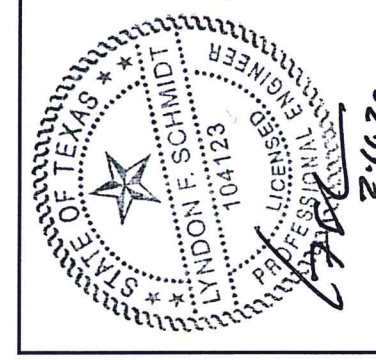

Documents Prepared By: Lyndon F. Schmidt, P.E.
 TEXAS P.E. #104123

RW BUILDING CONSULTANTS, INC.
 P.O. Box 230 Valrico FL, 33595
 Phone No.: 813.659.9197

TEXAS BOARD OF PROFESSIONAL ENGINEERS
 CERTIFICATE OF REGISTRATION # F-11852

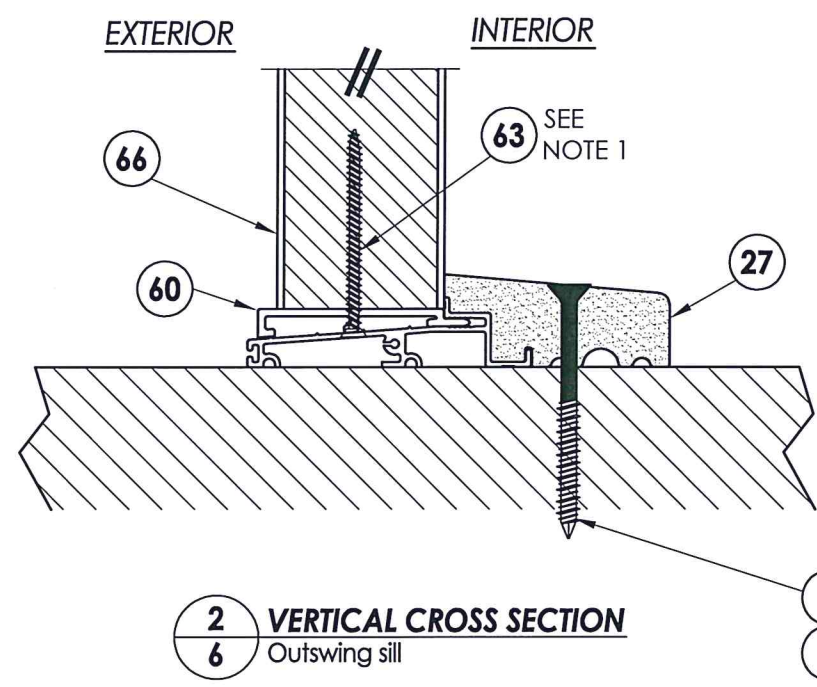
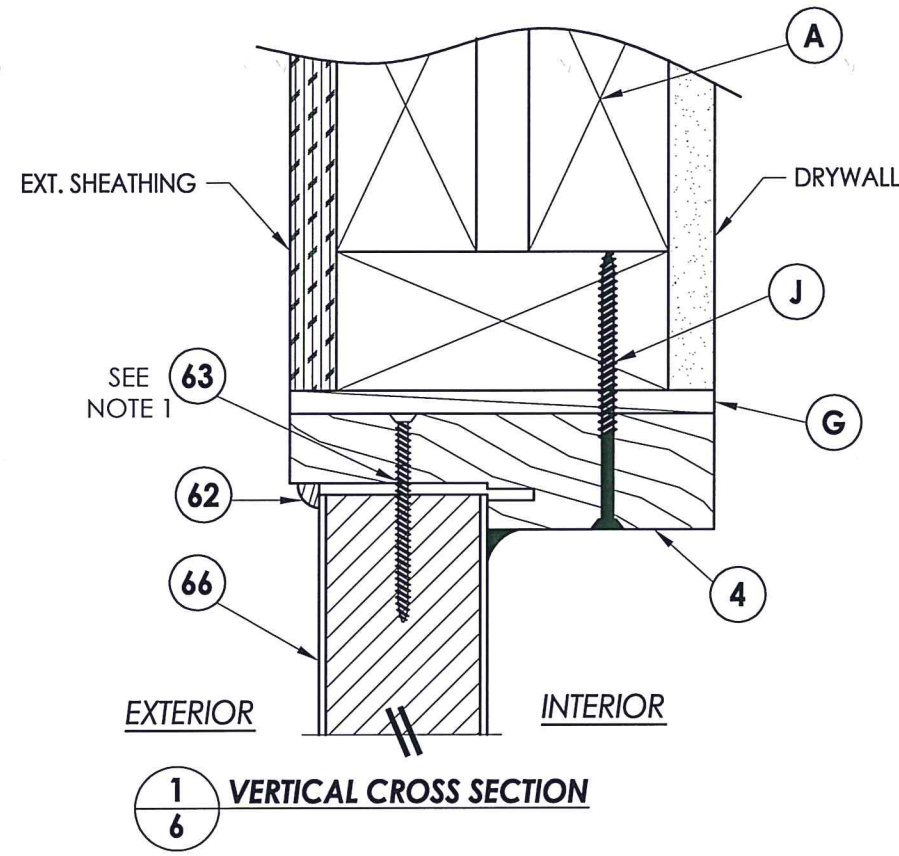

NOTE:
 1. Screws thru head and sill jamb located 3" from each end and on center line.

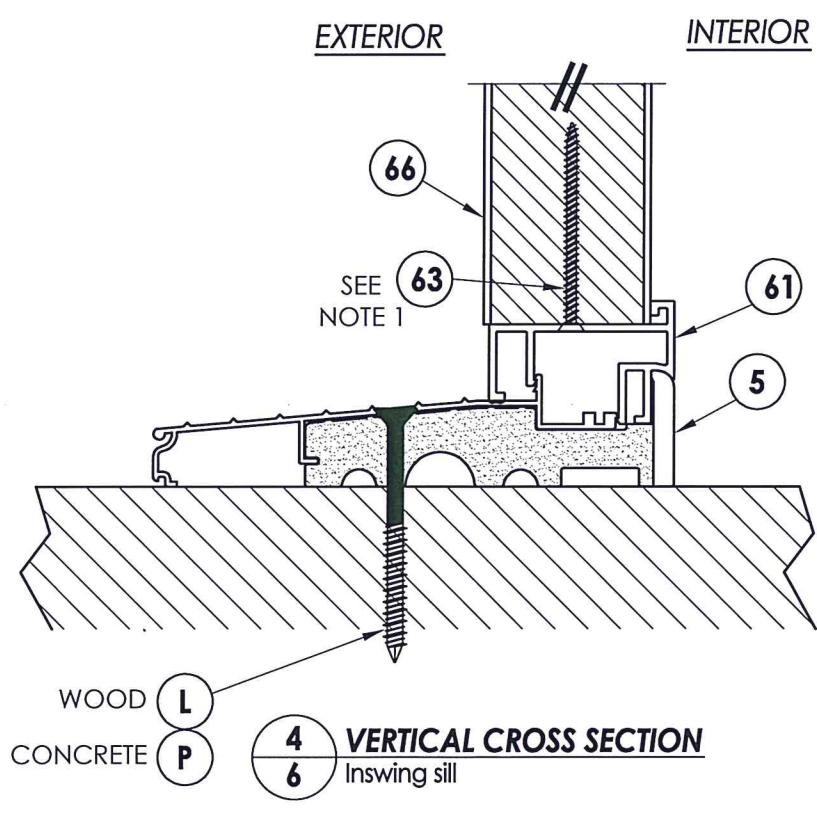
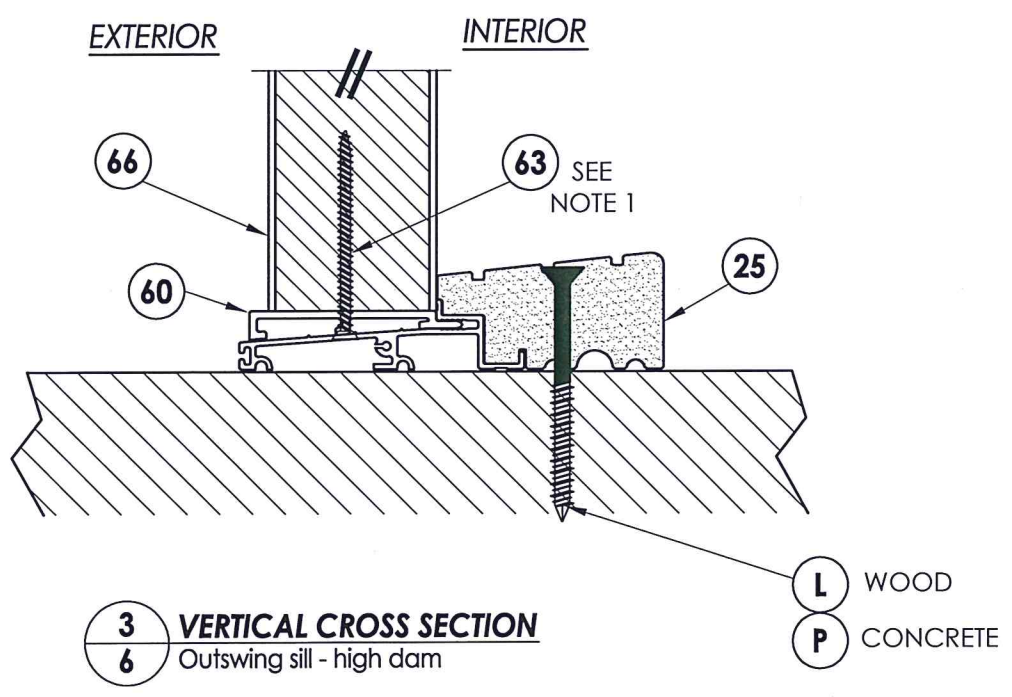

PRODUCT:		TRINITY GLASS INT'L 6 8 PREMIUM OPAQUE	
PART OR ASSEMBLY:		VERTICAL CROSS SECTIONS	
NO.	DATE	BY	REVISIONS
3	2/10/20	LFS	UPDATE TO 2018 IBC/IRC
2	7/27/09	AL	TDI PRODUCT EVALUATION UPDATE
1	6/28/06	EW	REVISED LOCKSET NOMENCLATURE
DATE: 8/25/05			
SCALE: N.T.S.			
DWG. BY: EW			
CHK. BY: LFS			
DRAWING NO.: TX-590			
SHEET 6 OF 9			

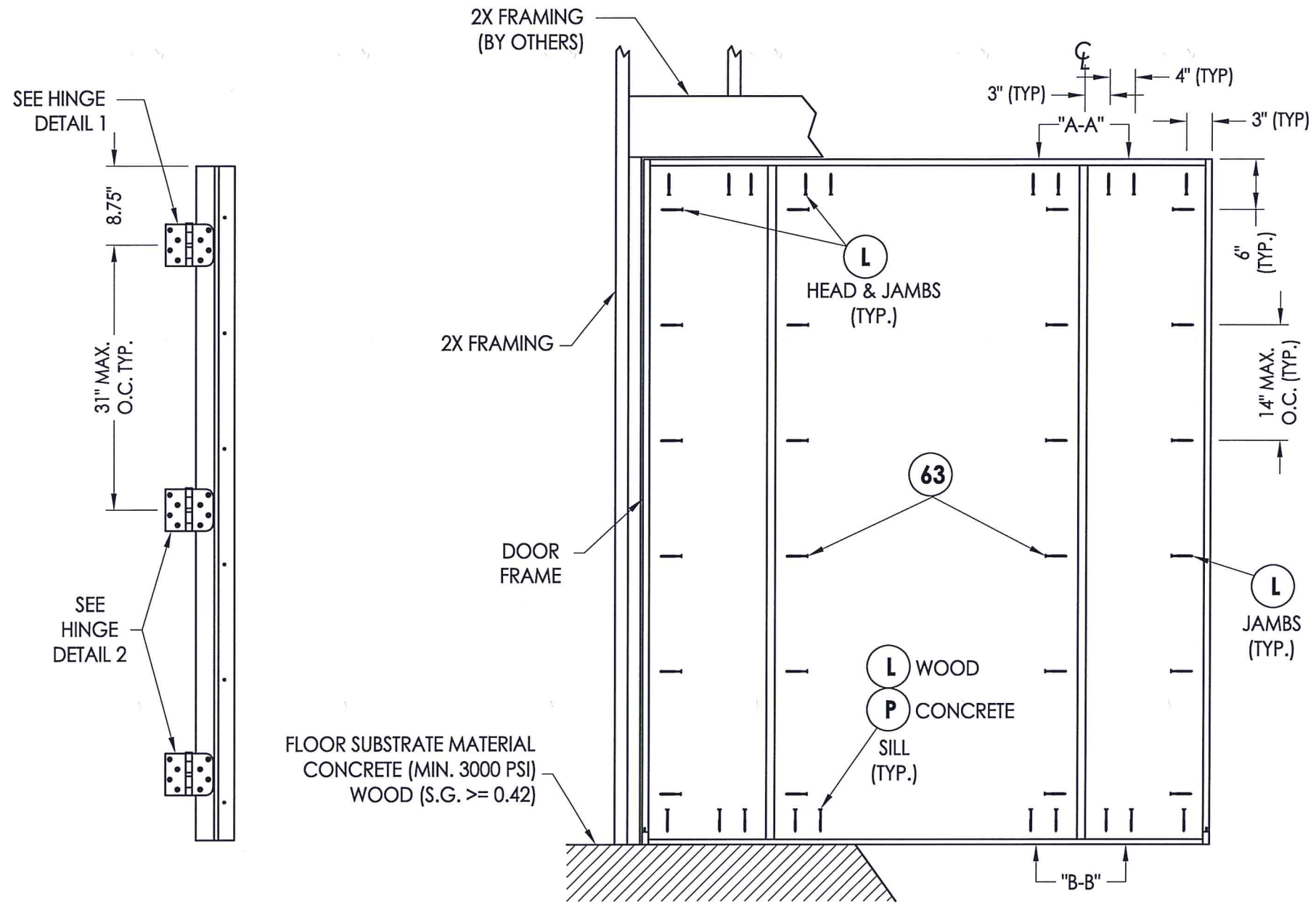

HINGE MULLION

FRAME ANCHORING
Stud construction

STRIKE MULLION

STRIKE PLATE DETAIL

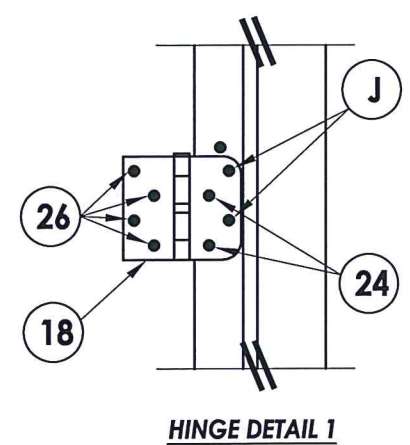

HINGE DETAIL 1

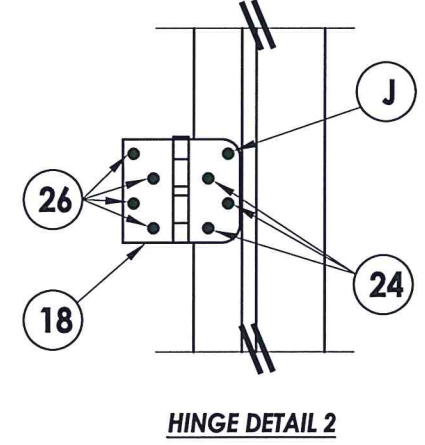

HINGE DETAIL 2

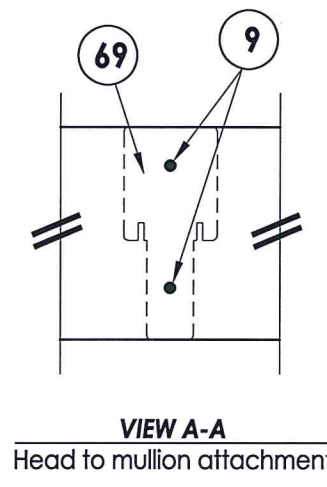

VIEW A-A
Head to mullion attachment

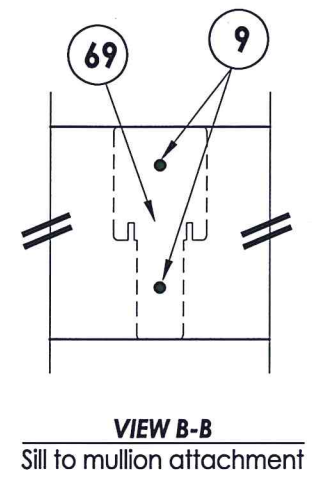

VIEW B-B
Sill to mullion attachment

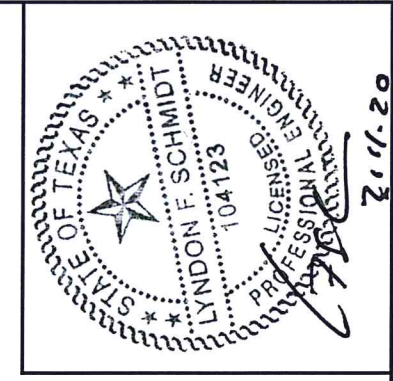

Documents Prepared By: Lyndon F. Schmidt, P.E.
TEXAS P.E. #104123

RW BUILDING CONSULTANTS, INC.
P.O. Box 230 Valrico FL, 33595
Phone No.: 813.659.9197

TEXAS BOARD OF PROFESSIONAL ENGINEERS
CERTIFICATE OF REGISTRATION # F-11852

PRODUCT: TRINITY GLASS INT'L
6 8 PREMIUM OPAQUE

PART OR ASSEMBLY: FRAME ANCHORING

NO.	DATE	REVISIONS
3	2/10/20	UPDATE TO 2018 IBC/IRC
2	7/27/09	TDI PRODUCT EVALUATION UPDATE
1	6/28/06	REVISED LOCKSET NOMENCLATURE
		BY

DATE: 8/25/05

SCALE: N.T.S.

DWG. BY: EW

CHK. BY: LFS

DRAWING NO.: TX-590

SHEET 7 OF 9

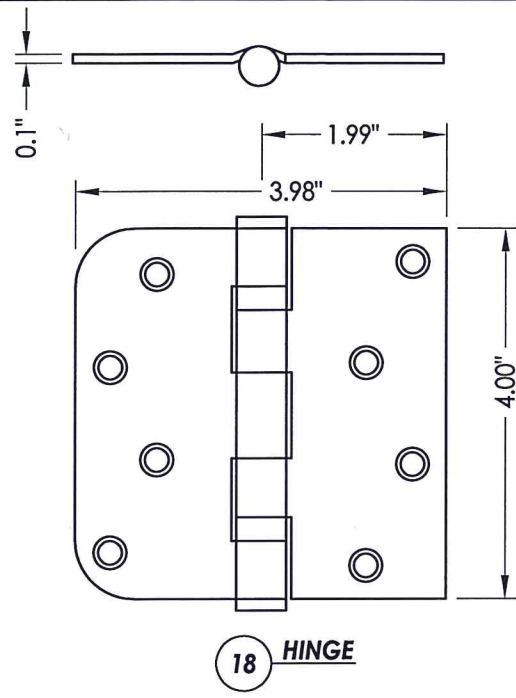

18 HINGE

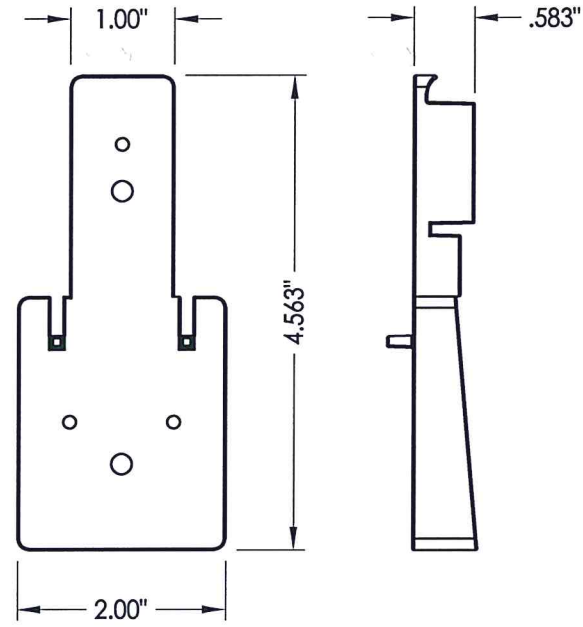

69 MULLION BASE KIT
Optional

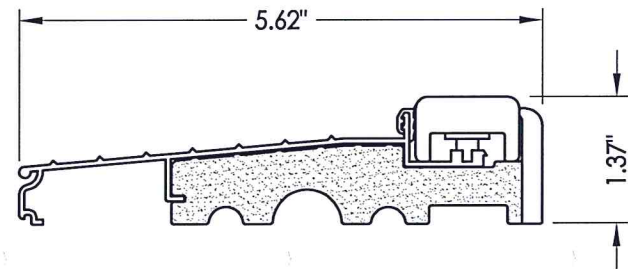

5 INSWING THRESHOLD

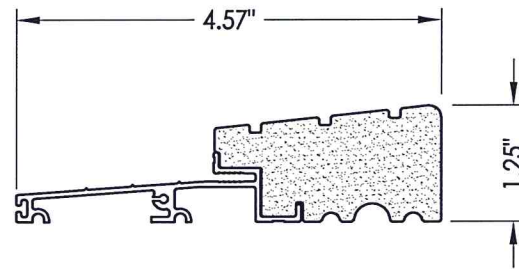

25 OUTSWING THRESHOLD
High-dam option

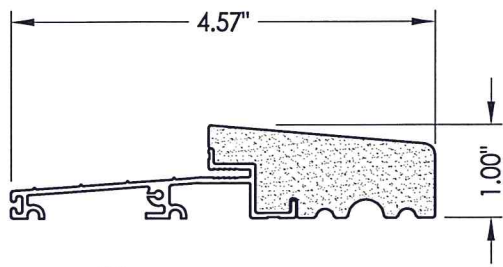

27 OUTSWING THRESHOLD



6 DOOR BOTTOM SWEEP

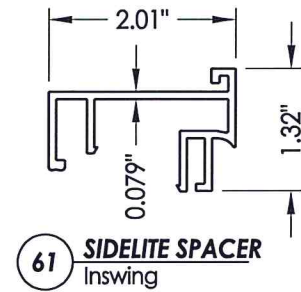

61 SIDELITE SPACER
Inswing

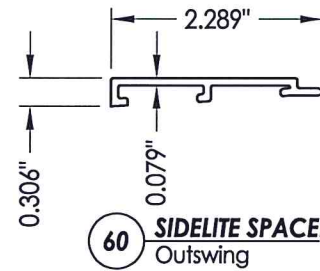

60 SIDELITE SPACER
Outswing

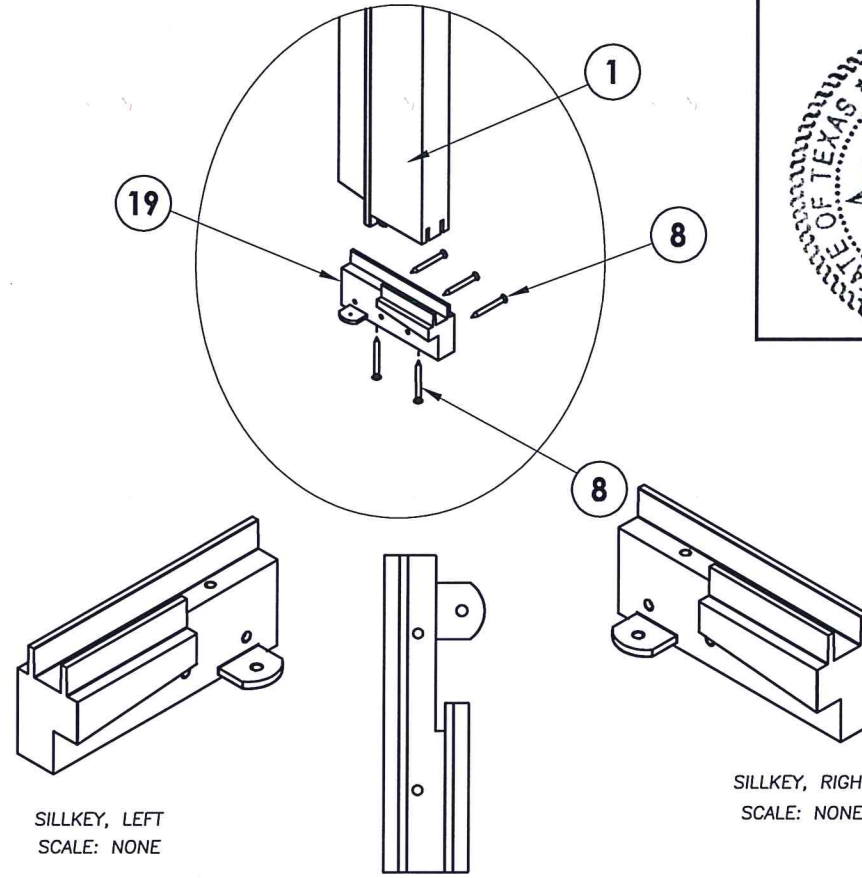

19 SILLKEY DETAILS
Optional

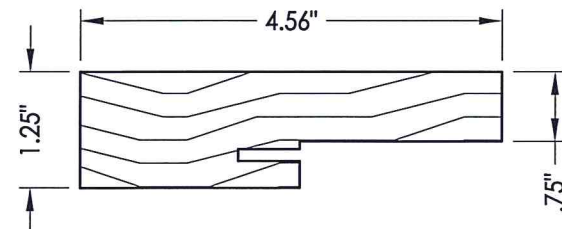
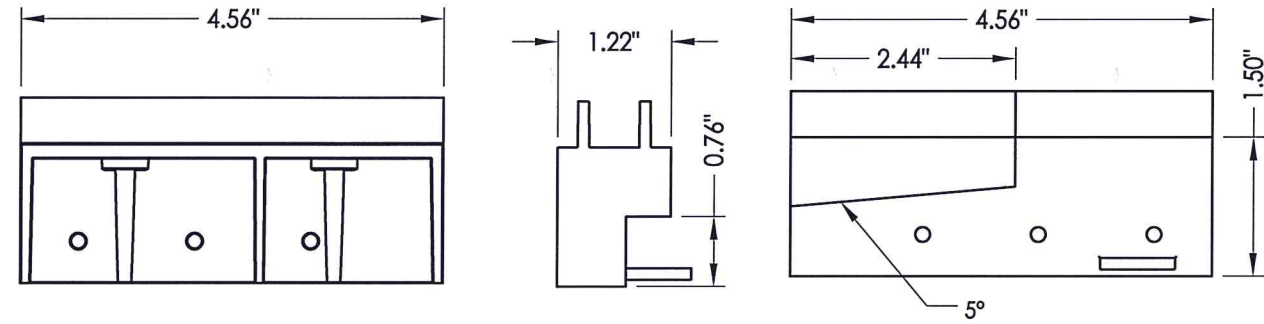

4 1 SIDE & HEAD JAMBS



Documents Prepared By: Lyndon F. Schmidt, P.E.
TEXAS P.E. #104123

RW BUILDING CONSULTANTS, INC.
P.O. Box 230 Valrico FL 33595
Phone No.: 813.669.9197

TEXAS BOARD OF PROFESSIONAL ENGINEERS
CERTIFICATE OF REGISTRATION # F-11852

PRODUCT:		TRINITY GLASS INT'L 6'8 PREMIUM OPAQUE	
PART OR ASSEMBLY:		COMPONENTS	
NO.	DATE	REVISIONS	BY
3	2/10/20	UPDATE TO 2018 IBC/IRC	LFS
2	7/27/09	TDI PRODUCT EVALUATION UPDATE	AL
1	6/28/06	REVISED LOCKSET NOMENCLATURE	EW
DATE:		8/25/05	
SCALE:		N.T.S.	
DWG. BY:		EW	
CHK. BY:		LFS	
DRAWING NO.:		TX-590	
SHEET		8 OF 9	

BILL OF MATERIALS		
ITEM	DESCRIPTION	MATERIAL
A	2X HEADER FRAMING SG >= 0.42	WOOD
B	2X FRAMING SG >= 0.42	WOOD
G	MAX. 1/4" SHIM SPACE	WOOD
J	#9 X 2-1/4" PFH WS	STEEL
L	#8 X 3" PFH WS	STEEL
P	3/16" X 2-3/4" ITW PFH CONCRETE SCREW	STEEL
1	SIDELITE JAMB - FINGER-JOINT PINE - SG >= 0.42	WOOD
4	HEAD - FINGER-JOINT PINE - SG >= 0.42	WOOD
5	INSWING THRESHOLD ALUMINUM W/ COMPOSITE SUBSTRATE	ALUMINUM
6	DOOR BOTTOM SWEEP	PVC
7	DOOR PANEL - SEE DOOR PANEL DETAIL SHEET FOR CONSTRUCTION DETAILS	-
8	#6 X 1-1/4 PFH DRYWALL SCREW	STEEL
9	#9 X 2-1/4" PFH WOOD SCREW	STEEL
12	WEATHER STRIP QEBD650 Q-LON	-
18	3.983" X 4.0" HINGE MIN 0.098" THICK	STEEL
19	SILLKEY	PC/ASA
21	LOCK (SEE LOCK & DEADBOLT RATINGS CHART)	STEEL
22	DEADBOLT (SEE LOCK & DEADBOLT RATINGS CHART)	STEEL
23	STRIKE PLATE	STEEL
23A	DEADBOLT PLATE	STEEL
24	#9 X 5/8" PFH WS	STEEL
25	OUTSWING HIGH-DAM THRESHOLD ALUMINUM W/ COMPOSITE SUBSTRATE	ALUM./ COMP.
26	#9 X 1.0" PFH WS	STEEL
27	OUTSWING THRESHOLD ALUMINUM W/ COMPOSITE SUBSTRATE	ALUM./ COMP.
30	LATCH STILE - SG >= 0.42	LVL/PVC
31	LVL LOCK BLOCK	POPLAR
32	HINGE STILE - SG >= 0.42	LVL/PVC
33	TOP RAIL - POPLAR LVL & WPC COMBINATION	POPLAR/WPC
34	BOTTOM RAIL - POPLAR LVL & WPC COMBINATION	POPLAR/WPC
39	FIBERGLASS SKIN 0.079" MIN. THICKNESS (Fy = 5,203 PSI MIN.)	FIBERGLASS
40	#8 X 1-1/8" SELF THREADING SCREW	STEEL
42	ALUMINUM & BUTYL SPACER SYSTEM	ALUM./BUTYL
44	HOT MELT SEALANT / SILICONE	-
45	LITE FRAME	PC/ASA
46	FOAM CORE	POLYURETHANE
60	SIDELITE SPACER - OUTSWING	PVC
61	SIDELITE SPACER - INSWING	PVC
62	QUARTER ROUND	WOOD
63	#8 x 2-1/4" PFH SCREW	STEEL
64	#8 x 2" PFH SCREW	STEEL
66	SIDELITE PANEL - SEE SIDELITE PANEL DETAIL SHEET FOR CONSTRUCTION DETAILS	-
67	INTEGRAL MULLION - FINGER JOINT PINE (SG >= 0.42)	WOOD
69	MULLION BASE KIT	PC/ASA
73	LVL SIDELITE TOP RAIL (FULL LITE)	POPLAR
74	LVL SIDELITE BOTTOM RAIL (FULL LITE)	POPLAR
75	LVL SIDELITE STILE (FULL LITE)	POPLAR

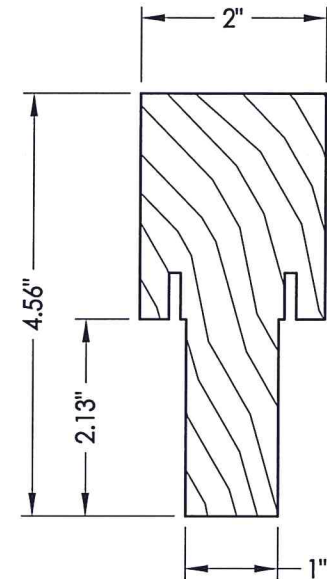

67 INTEGRAL MULLION

CONCRETE ANCHOR NOTES:

- Concrete anchor locations at the corners may be adjusted to maintain the min. edge distance to mortar joints.
- Concrete anchor locations noted as "MAX. ON CENTER" must be adjusted to maintain the min. edge distance to mortar joints, additional concrete anchors may be required to ensure the "MAX. ON CENTER" dimension are not exceeded.
- Concrete anchor table:

ANCHOR TYPE	ANCHOR SIZE	MIN. EMBEDMENT	MIN. CLEARANCE TO MASONRY EDGE	MIN. CLEARANCE TO ADJACENT ANCHOR
ITW BUILDEX TAPCON®	1/4"	1-3/4"	2"	4"
ELCO ULTRACON®	1/4"	1-3/4"	1"	4"

WOOD SCREW INSTALLATION NOTES:

- Maintain a minimum 5/8" edge distance, 1" end distance, & 1" o.c. spacing of wood screws to prevent the splitting of wood.

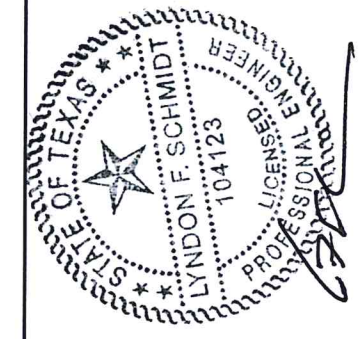

Documents Prepared By: Lyndon F. Schmidt, P.E.
TEXAS P.E. #104123

RW BUILDING CONSULTANTS, INC.
P.O. Box 230 Valrico FL, 33595
Phone No.: 813.659.9197

TEXAS BOARD OF PROFESSIONAL ENGINEERS
CERTIFICATE OF REGISTRATION # F-11852

PRODUCT: TRINITY GLASS INT'L
6"8 PREMIUM OPAQUE

PART OR ASSEMBLY:
BILL OF MATERIALS & COMPONENTS

NO.	DATE	REVISIONS
3	2/10/20	UPDATE TO 2018 IBC/IRC
2	7/27/09	TDI PRODUCT EVALUATION UPDATE
1	6/28/06	REVISED LOCKSET NOMENCLATURE

DATE: 8/25/05

SCALE: N.T.S.

DWG. BY: EW

CHK. BY: LFS

DRAWING NO.: TX-590

SHEET 9 OF 9