

KAWNEER COMPANY, INC.

INSULPOUR 500T THERMAL ENTRANCE (IMPACT)



555 GUTHRIDGE CT
NORCROSS, GA 30092
PH: (770) 840-6431

TITLE: INSULPOUR 500T THERMAL ENTRANCE (IMPACT)

INSTALLATION & GENERAL NOTES

PREPARED BY: BUILDING DROPS, INC.
398 E. DANIA BEACH BLVD., STE. 338
DANIA BEACH, FL 33004
PH: (954) 399-8478
FAX: (954) 744-4738
WEB: www.buildingdrops.com



INSTALLATION NOTES:

- ONE (1) INSTALLATION ANCHOR IS REQUIRED AT EACH ANCHOR LOCATION SHOWN.
- THE NUMBER OF INSTALLATION ANCHORS DEPICTED IS THE MINIMUM NUMBER OF ANCHORS TO BE USED FOR PRODUCT INSTALLATION.
- INSTALL INDIVIDUAL INSTALLATION ANCHORS WITHIN A TOLERANCE OF ±1/2 INCH OF THE DEPICTED LOCATION IN THE ANCHOR LAYOUT DETAIL (I.E., WITHOUT CONSIDERATION OF TOLERANCES). TOLERANCES ARE NOT CUMULATIVE FROM ONE INSTALLATION ANCHOR TO THE NEXT.
- SHIM AS REQUIRED AT EACH INSTALLATION ANCHOR WITH LOAD BEARING SHIM(S). MAXIMUM ALLOWABLE SHIM STACK TO BE 3/8 INCH. SHIM WHERE SPACE OF 1/16 INCH OR GREATER OCCURS. SHIM(S) SHALL BE CONSTRUCTED OF HIGH DENSITY PLASTIC OR BETTER.
- MINIMUM EMBEDMENT AND EDGE DISTANCE EXCLUDE WALL FINISHES, INCLUDING BUT NOT LIMITED TO STUCCO, FOAM, BRICK VENEER, AND SIDING.
- INSTALLATION ANCHORS AND ASSOCIATED HARDWARE MUST BE MADE OF CORROSION RESISTANT MATERIAL OR HAVE A CORROSION RESISTANT COATING.
- FOR HOLLOW BLOCK AND GROUT FILLED BLOCK, DO NOT INSTALL INSTALLATION ANCHORS INTO MORTAR JOINTS. EDGE DISTANCE IS MEASURED FROM FREE EDGE OF BLOCK OR EDGE OF MORTAR JOINT INTO FACE SHELL OF BLOCK.
- INSTALLATION ANCHORS SHALL BE INSTALLED IN ACCORDANCE WITH ANCHOR MANUFACTURER'S INSTALLATION INSTRUCTIONS, AND ANCHORS SHALL NOT BE USED IN SUBSTRATES WITH STRENGTHS LESS THAN THE MINIMUM STRENGTH SPECIFIED BY THE ANCHOR MANUFACTURER.
- INSTALLATION ANCHOR CAPACITIES FOR PRODUCTS HEREIN ARE BASED ON SUBSTRATE MATERIALS WITH THE FOLLOWING PROPERTIES:
 - WOOD - MINIMUM SPECIFIC GRAVITY OF 0.42.
 - CONCRETE - MINIMUM COMPRESSIVE STRENGTH OF 3000 PSI.
 - MASONRY - STRENGTH CONFORMANCE TO ASTM C-90, WITH MINIMUM COMPRESSIVE STRENGTH OF 2000 PSI.
 - STEEL - MINIMUM YIELD STRENGTH OF 36 KSI. MINIMUM 12 GA. WALL THICKNESS.
 - ALUMINUM - MINIMUM 1/8 INCH THICK 6063-T5 ALUMINUM.

GENERAL NOTES:

- THE PRODUCT SHOWN HEREIN IS DESIGNED AND MANUFACTURED TO COMPLY WITH THE 2018 IBC, IRC AND HAS BEEN EVALUATED ACCORDING TO THE FOLLOWING:
 - AAMA 501-15
 - AAMA 1304-02
 - ASTM E1886-13a
 - ASTM E1996-14a
 - TAS 201-94
 - TAS 202-94
 - TAS 203-94
- ADEQUACY OF THE EXISTING STRUCTURAL CONCRETE/MASONRY, 2X FRAMING AND METAL STUD FRAMING AS A MAIN WIND FORCE RESISTING SYSTEM CAPABLE OF WITHSTANDING AND TRANSFERRING APPLIED PRODUCT LOADS TO THE FOUNDATION IS THE RESPONSIBILITY OF THE ENGINEER OR ARCHITECT OF RECORD FOR THE PROJECT OF INSTALLATION.
- 1X AND 2X BUCKS (WHEN USED) SHALL BE DESIGNED AND ANCHORED TO PROPERLY TRANSFER ALL LOADS TO THE STRUCTURE. BUCK DESIGN AND INSTALLATION IS THE RESPONSIBILITY OF THE ENGINEER OR ARCHITECT OF RECORD FOR THE PROJECT OF INSTALLATION.
- THE INSTALLATION DETAILS DESCRIBED HEREIN ARE GENERIC AND MAY NOT REFLECT ACTUAL CONDITIONS FOR A SPECIFIC SITE. IF SITE CONDITIONS CAUSE INSTALLATION TO DEVIATE FROM THE REQUIREMENTS DETAILED HEREIN, A LICENSED ENGINEER OR ARCHITECT SHALL PREPARE SITE SPECIFIC DOCUMENTS FOR USE WITH THIS DOCUMENT.
- APPROVED IMPACT PROTECTIVE SYSTEM **IS NOT REQUIRED** ON THIS PRODUCT IN AREAS REQUIRING IMPACT RESISTANCE COVERING.
- DOOR FRAME MATERIAL: ALUMINUM 6063-T6
- ALL STRUCTURAL MATERIALS & DISSIMILIAR METALS SHALL BE PROTECTED, TREATED, PAINTED, COATED, AND/OR ISOLATED AS REQUIRED IN THE APPLICABLE SECTIONS OF THE 2018 INTERNATIONAL BUILDING CODE AND REFERENCED DESIGN SPECIFICATIONS.
- GLASS MEET THE REQUIREMENTS OF ASTM E 1300 GLASS CHARTS. SEE SHEET 8 GLAZING DETAILS.
- ALLOWABLE CONFIGURATIONS: X (SINGLE DOOR) OR XX (DOUBLE DOOR)

TABLE OF CONTENTS	
SHEET	SHEET DESCRIPTION
1	INSTALLATION & GENERAL NOTES
2	ELEVATIONS AND ANCHOR LAYOUT
3	ELEVATIONS AND ANCHOR LAYOUT
4	VERTICAL SECTIONS
5	VERTICAL SECTIONS AND DETAILS
6	HORIZONTAL SECTIONS
7	HORIZONTAL SECTIONS
8	GLAZING DETAILS
9	BILL OF MATERIALS
10	COMPONENTS

DESIGN PRESSURE TABLE		
CONFIGURATION	DESIGN PRESSURE	IMPACT RATING
SINGLE DOORS	+/-70	IMPACT
DOUBLE DOORS	+/-70	

REMARKS	BY	DATE

THE INSTALLATION DETAILS DESCRIBED HEREIN ARE GENERIC AND MAY NOT REFLECT ACTUAL CONDITIONS FOR A SPECIFIC SITE. IF SITE CONDITIONS CAUSE INSTALLATION TO DEVIATE FROM THE REQUIREMENTS DETAILED HEREIN, A LICENSED ENGINEER OR ARCHITECT SHALL PREPARE SITE SPECIFIC DOCUMENTS FOR USE WITH THIS DOCUMENT



HERMES F. NORERO, P.E.
TEXAS P.E. No 118471
BUILDING DROPS, INC
398 E. DANIA BEACH BLVD. # 338
DANIA BEACH, FL 33004
TBPE FIRM No. 13734

DATE: **02.11.21**

DWG. BY: **ER** CHK. BY: **HFN**

SCALE: **NTS**

DWG. #: **KAW021**

SHEET: **1** OF 10

12/8/2021 2:43 PM s:\projects\kawneer company\tdr-21-0118 -tdl-submittal\dwgs\128914\kaw021.dwg

*NOTE: CROSSRAILS ARE QUALIFIED ON SINGLE AND DOUBLE DOORS USING 451T SUBFRAME AND 1600 WALL SYSTEM

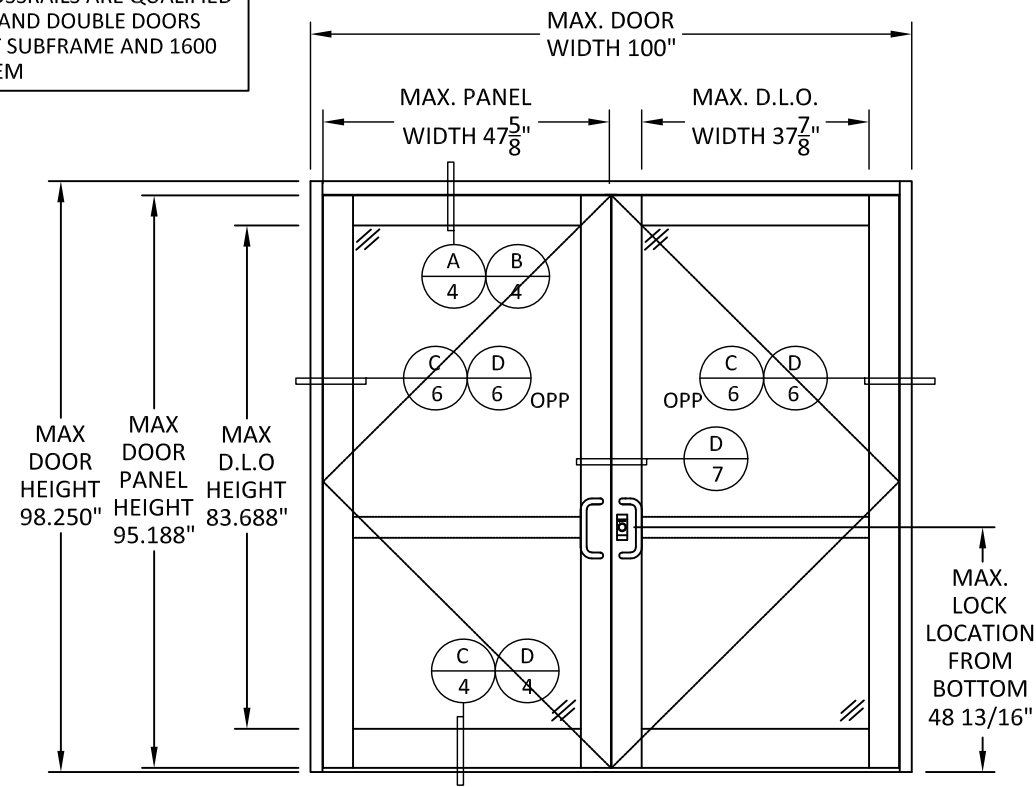

ELEVATION

500T THERMAL DOOR WITH 451T SUBFRAME

TABLE 1- SINGLE AND DOUBLE DOOR QUALIFIED HINGES		
DP RATING	IMPACT	HARDWARE
+/-70 PSF	LARGE/SMALL MISSILE	STANDARD BUTT HINGE
+/-70 PSF	LARGE/SMALL MISSILE	RIXSON OFFSET PIVOT
+/-70 PSF	LARGE/SMALL MISSILE	ROTON CONT. GEARED HINGE

TABLE 2-SINGLE & DOUBLE DOORS QUALIFIED HARDWARE		
DP RATING	IMPACT	HARDWARE
+/-70 PSF	LARGE/SMALL MISSILE	KAWNEER 1686 CVR PANIC DEVICE
+/-70 PSF	LARGE/SMALL MISSILE	FALCON HH1690 CONCEALED ROD EXIT DEVICE
+/-70 PSF	LARGE/SMALL MISSILE	VON DUPRIN HH9947 EXIT DEVICE
+/-70 PSF	LARGE/SMALL MISSILE	MS 1850 - 3 POINT LOCK & FLUSH BOLTS

* = LOCATION OF F-CLIP #30
 Δ = LOCATION OF SHEAR BLOCK #33

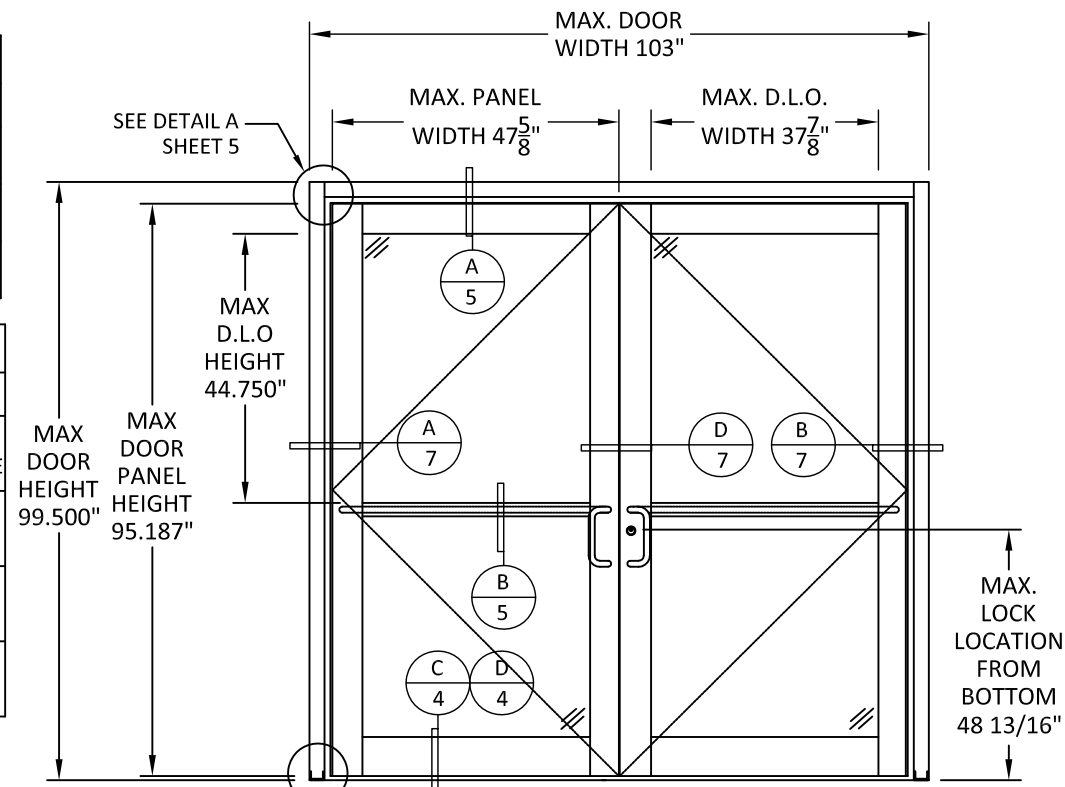

ELEVATION

500T THERMAL DOOR WITH 1600 WALL SYSTEM

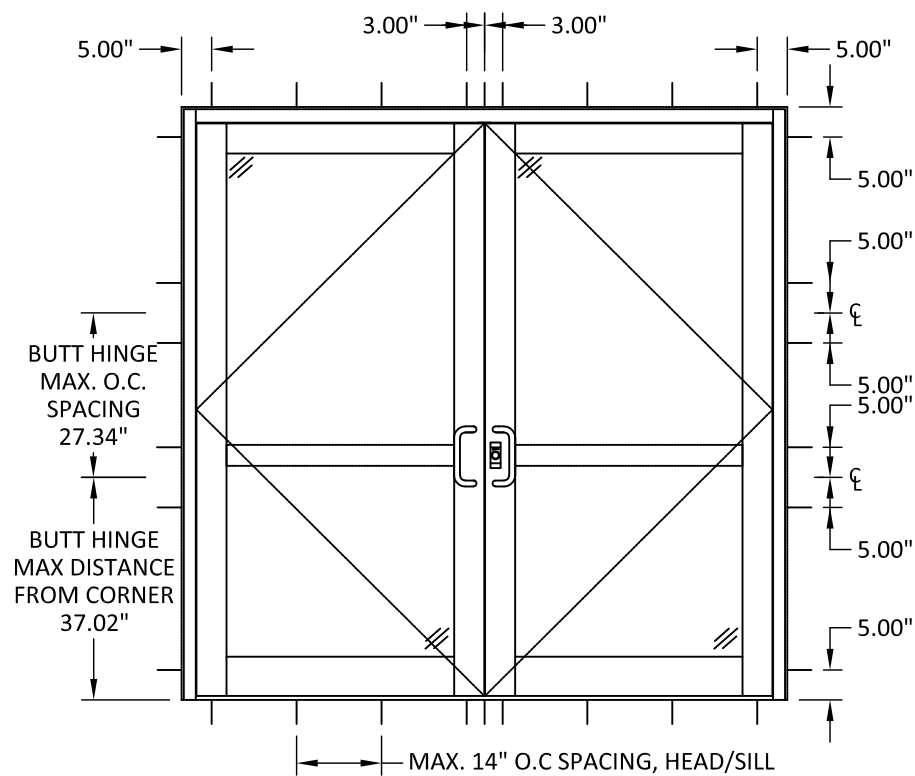

ANCHOR LAYOUT

500T THERMAL DOOR WITH 451T SUBFRAME W/ BUTT HINGE

JAMB USING CONTINUOUS HINGES SHALL HAVE ANCHOR LOCATED AT A MAX 6" FROM CORNER AND 17" MAX. O.C SPACING

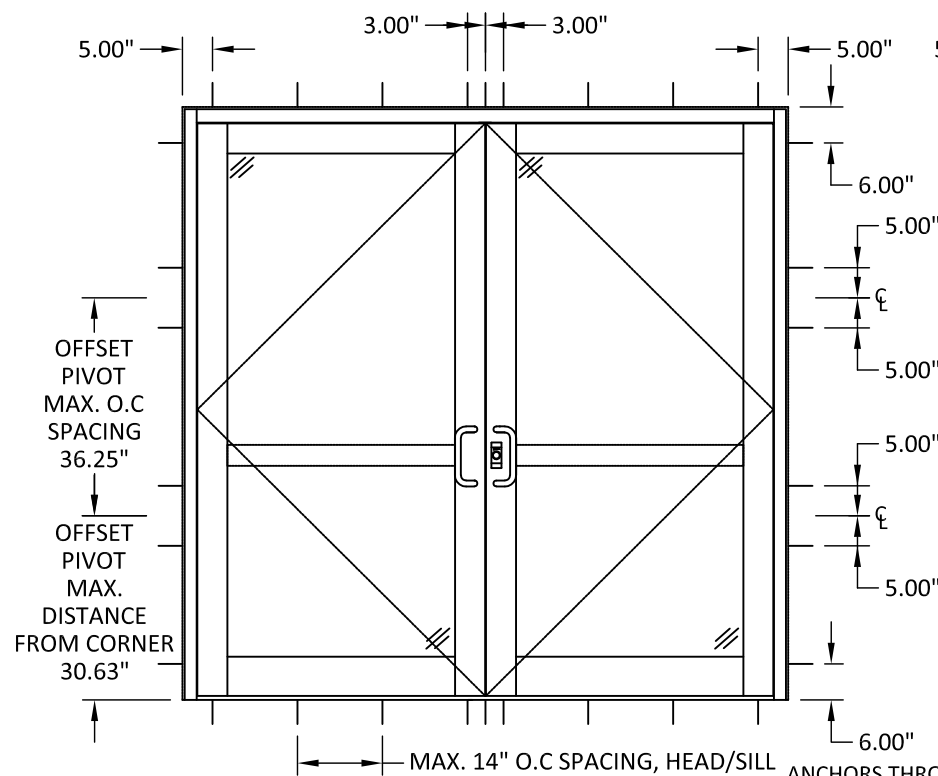

ANCHOR LAYOUT

500T THERMAL DOOR WITH 451T SUBFRAME W/ OFFSET PIVOT

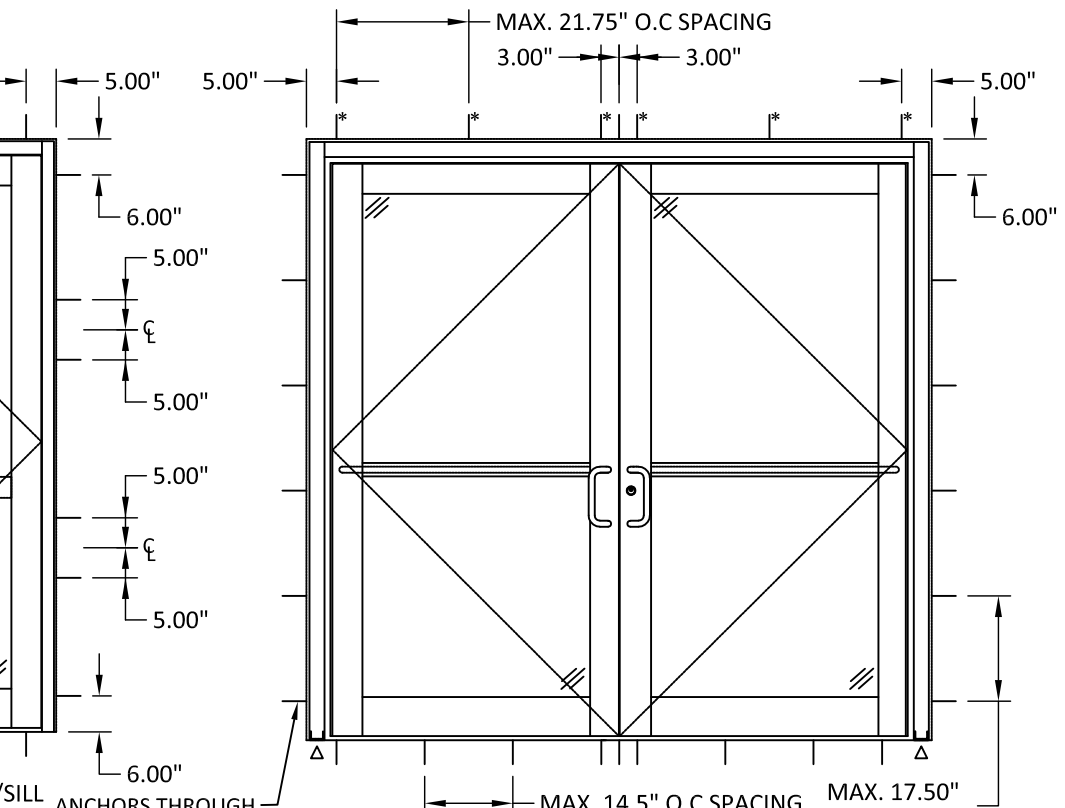

ANCHOR LAYOUT

500T THERMAL DOOR WITH 1600 WALL SYSTEM



555 GUTHRIDGE CT
 NORCROSS, GA 30092
 PH: (770) 840-6431

TITLE: INSULPOUR 500T THERMAL ENTRANCE (IMPACT)
 ELEVATIONS & ANCHOR LAYOUT
 PREPARED BY: BUILDING DROPS, INC.
 398 E. DANIA BEACH BLVD., STE. 338
 DANIA BEACH, FL 33004
 PH: (954) 399-8478
 FAX: (954) 744-4738
 WEB: www.buildingdrops.com

REMARKS	BY	DATE

THE INSTALLATION DETAILS DESCRIBED HEREIN ARE GENERIC AND MAY NOT REFLECT ACTUAL CONDITIONS FOR A SPECIFIC SITE. IF SITE CONDITIONS CAUSE INSTALLATION TO DEVIATE FROM THE REQUIREMENTS DETAILED HEREIN, A LICENSED ENGINEER OR ARCHITECT SHALL PREPARE SITE SPECIFIC DOCUMENTS FOR USE WITH THIS DOCUMENT



HERMES F. NORERO, P.E.
 TEXAS P.E. No 118471
 BUILDING DROPS, INC
 398 E. DANIA BEACH BLVD. # 338
 DANIA BEACH, FL 33004
 TBPE FIRM No. 13734

DATE: 02.11.21
 DWG. BY: ER
 CHK. BY: HFN
 SCALE: NTS
 DWG. #: KAW021
 SHEET:

TITLE: **INSULPOUR 500T THERMAL ENTRANCE (IMPACT)**
ELEVATIONS AND ANCHOR LAYOUT

PREPARED BY: **BUILDING DROPS, INC.**
398 E. DANIA BEACH BLVD., STE. 338
DANIA BEACH, FL 33004
PH: (954) 399-8478
FAX: (954) 744-4738
WEB: www.buildingdrops.com

*NOTE: CROSSRAILS ARE QUALIFIED ON SINGLE AND DOUBLE DOORS USING 451T SUBFRAME AND 1600 WALL SYSTEM

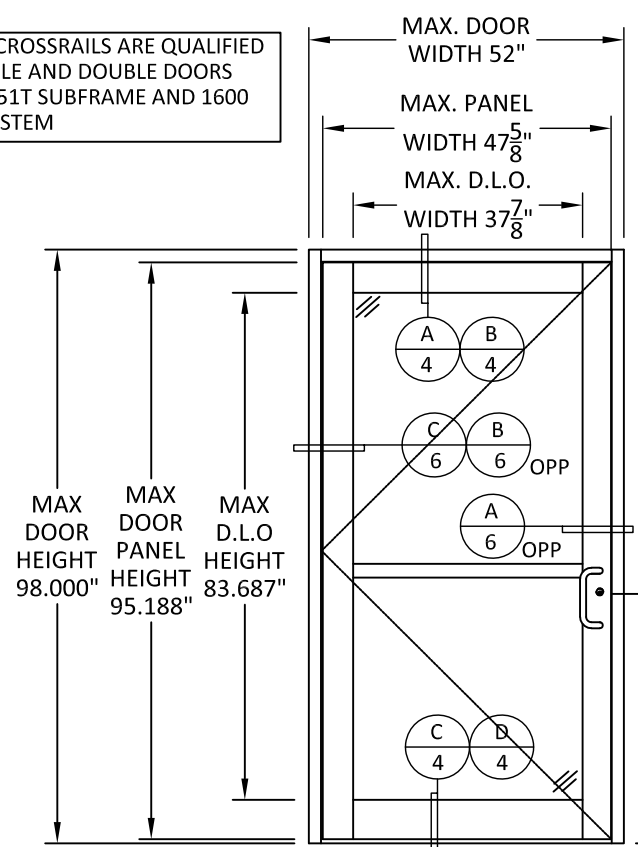

ELEVATION
500T THERMAL SINGLE DOOR WITH 451T SUBFRAME

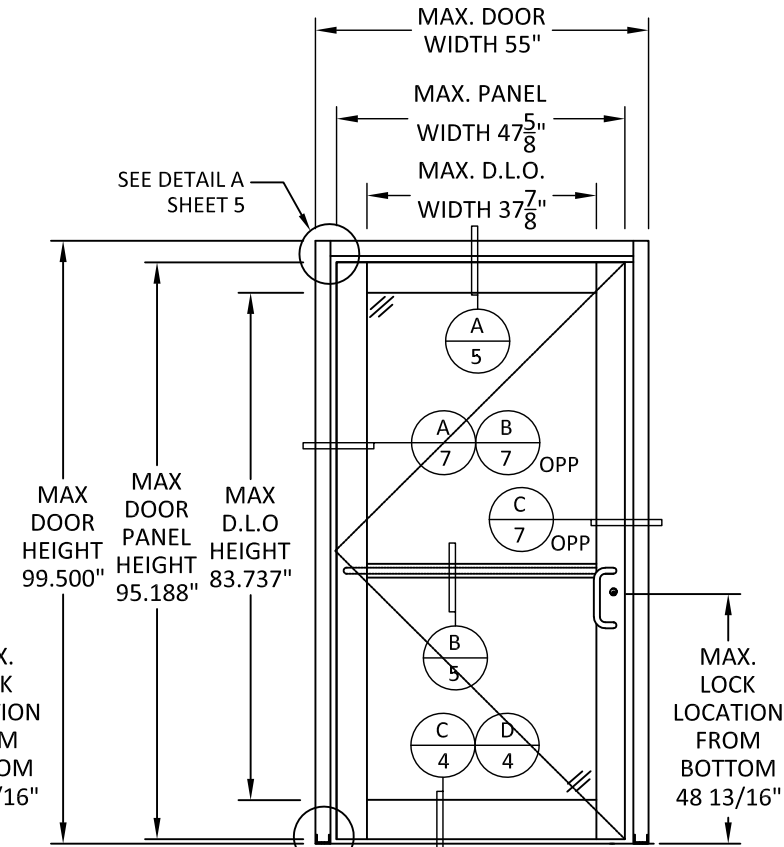

ELEVATION
500T THERMAL SINGLE DOOR WITH 1600 WALL SYSTEM

TABLE 3. ANCHOR SCHEDULE FOR DOUBLE AND SINGLE DOORS				
ANCHOR DESCRIPTION	SUBSTRATE REQUIREMENTS	MIN. EMBEDMENT	MIN. EDGE DISTANCE	NOTES
#12 WOOD ANCHOR	MIN. S.G.= 0.42 WOOD	1-1/2"	1"	-
1/4" CONCRETE ANCHOR	CONCRETE F'C=3000 PSI MIN.	1-1/4"	3.00"	ELCO ULTRACONS, ITW RED-HEADS, HILTI KWIK-CON II.
1/4" CONCRETE ANCHOR	C-90 HOLLOW/FILLED BLOCK AT JAMBS F'M=2000 PSI MIN.	1-1/4"	4.00"	ELCO ULTRACONS, ITW RED-HEADS, HILTI KWIK-CON II.
#12 DIA. SELF-DRILLING ANCHOR (GRADE 5)	STEEL: 12 GA. MIN., Fy=36KSI MIN. ALUM: 1/8" MIN, 6063-T5 MIN	3 THREADS PENETRATION BEYOND METAL STRUCTURE	3/4"	STEEL IN CONTACT WITH ALUM. TO BE PLATED OR PAINTED

* = LOCATION OF F-CLIP #30
Δ = LOCATION OF SHEAR BLOCK #33

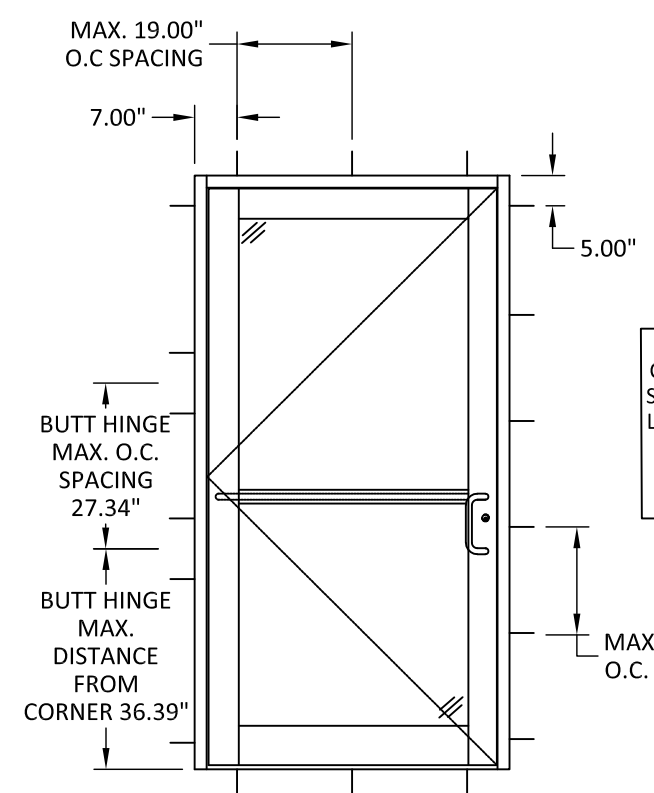

ANCHOR LAYOUT
500T THERMAL DOOR WITH 451T SUBFRAME W/ BUTT HINGE

JAMB USING CONTINUOUS HINGES SHALL HAVE ANCHORS LOCATED AT A MAX 6" FROM CORNER AND 17" MAX. O.C SPACING

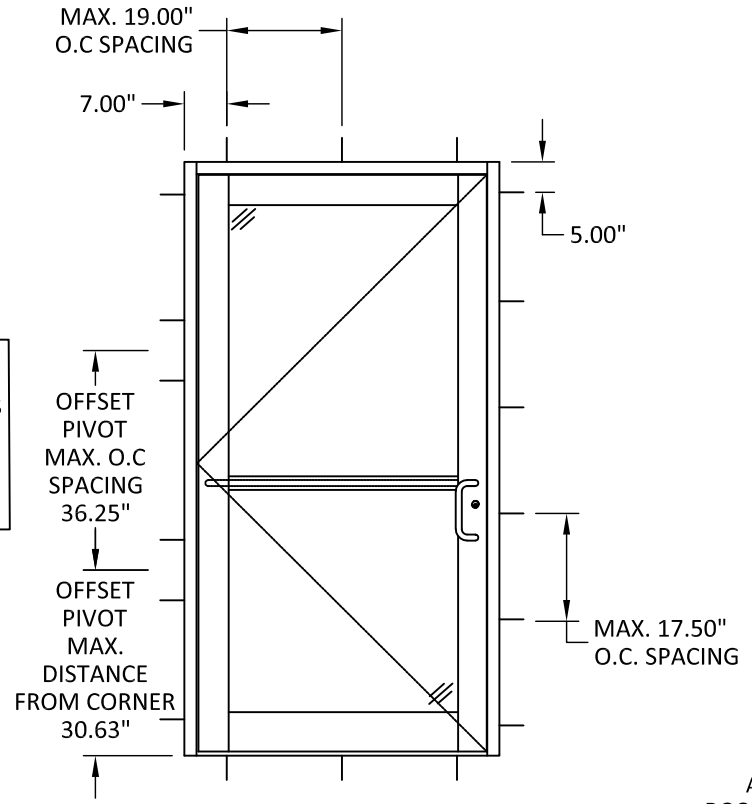

ANCHOR LAYOUT
500T THERMAL DOOR WITH 451T SUBFRAME W/ BUTT HINGE

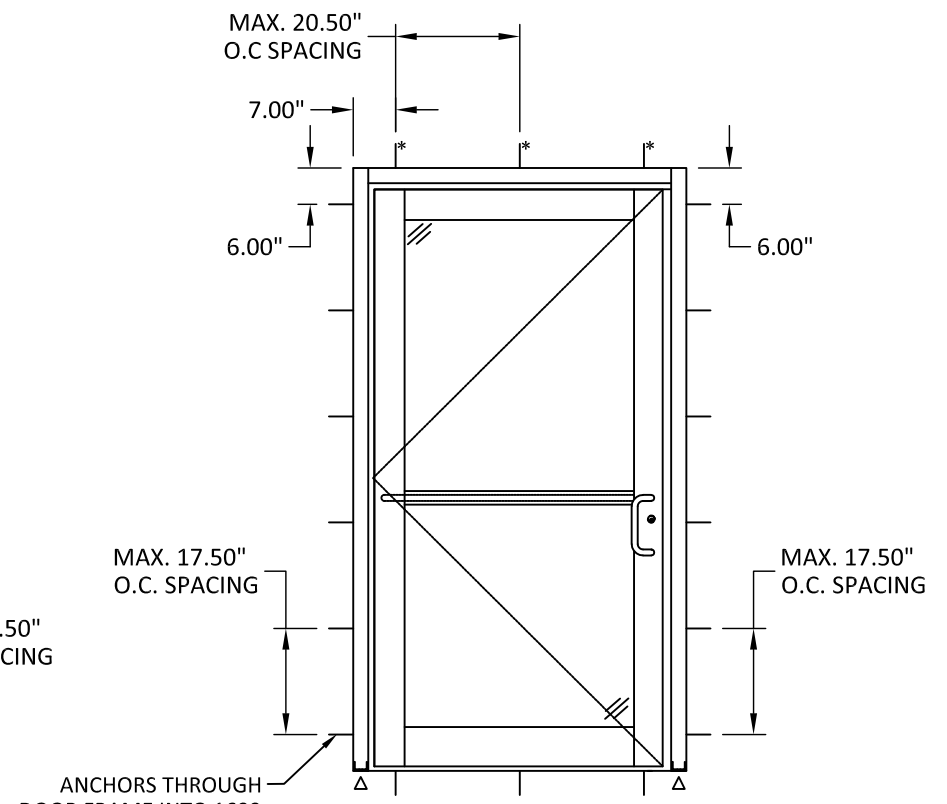

ANCHORS THROUGH DOOR FRAME INTO 1600 WALL SYSTEM. SEE SHEET 7 FOR DETAIL

ANCHOR LAYOUT
500T THERMAL DOOR WITH 1600 WALLSYSTEM

REMARKS	BY	DATE

THE INSTALLATION DETAILS DESCRIBED HEREIN ARE GENERIC AND MAY NOT REFLECT ACTUAL CONDITIONS FOR A SPECIFIC SITE. IF SITE CONDITIONS CAUSE INSTALLATION TO DEVIATE FROM THE REQUIREMENTS DETAILED HEREIN, A LICENSED ENGINEER OR ARCHITECT SHALL PREPARE SITE SPECIFIC DOCUMENTS FOR USE WITH THIS DOCUMENT



HERMES F. NORERO, P.E.
TEXAS P.E. No 118471
BUILDING DROPS, INC
398 E. DANIA BEACH BLVD. # 338
DANIA BEACH, FL 33004
TBPE FIRM No. 13734

DATE: **02.11.21**
DWG. BY: **ER** CHK. BY: **HFN**
SCALE: **NTS**
DWG. #: **KAW021**
SHEET:

12/8/2021 2:43 PM

s:\projects\kawneer company\tdr-21-0118 -tdf submittal\dwgs\128914\kaw021.dwg

TITLE: **INSULPOUR 500T THERMAL ENTRANCE (IMPACT)**
VERTICAL SECTIONS

PREPARED BY: **BUILDING DROPS, INC.**
398 E. DANIA BEACH BLVD., STE. 338
DANIA BEACH, FL 33004
PH: (954) 399-8478
FAX: (954) 744-4738
WEB: www.buildingdrops.com



REMARKS	BY	DATE

THE INSTALLATION DETAILS DESCRIBED HEREIN ARE GENERIC AND MAY NOT REFLECT ACTUAL CONDITIONS FOR A SPECIFIC SITE. IF SITE CONDITIONS CAUSE INSTALLATION TO DEVIATE FROM THE REQUIREMENTS DETAILED HEREIN, A LICENSED ENGINEER OR ARCHITECT SHALL PREPARE SITE SPECIFIC DOCUMENTS FOR USE WITH THIS DOCUMENT



HERMES F. NORERO, P.E.
TEXAS P.E. No 118471
BUILDING DROPS, INC
398 E. DANIA BEACH BLVD. # 338
DANIA BEACH, FL 33004
TBPE FIRM No. 13734

DATE:	02.11.21	
DWG. BY:	ER	CHK. BY: HFN
SCALE:	NTS	
DWG. #:	KAW021	
SHEET:	4	

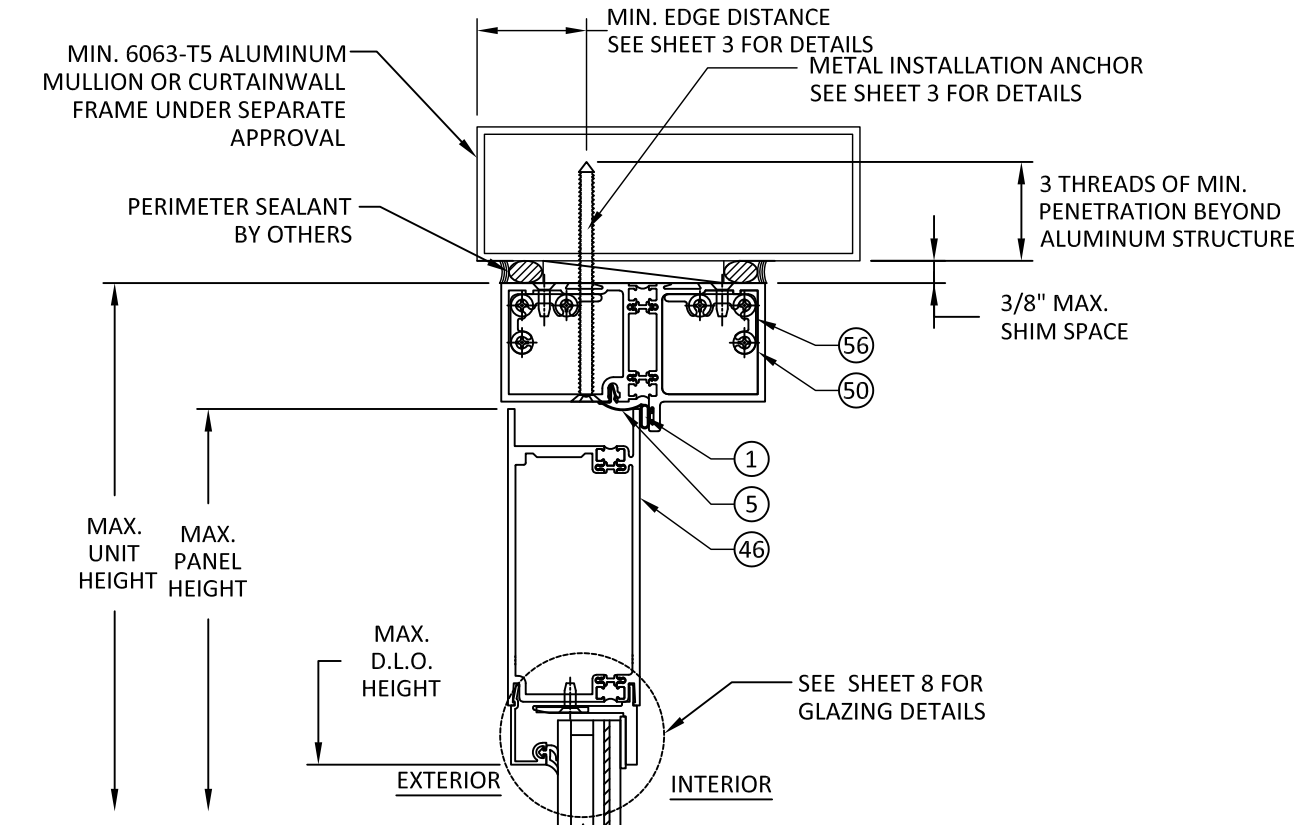

A
4 VERTICAL SECTION
500T DOOR & TRIFAB 451T SUBFRAME
HEAD-METAL STRUCTURE

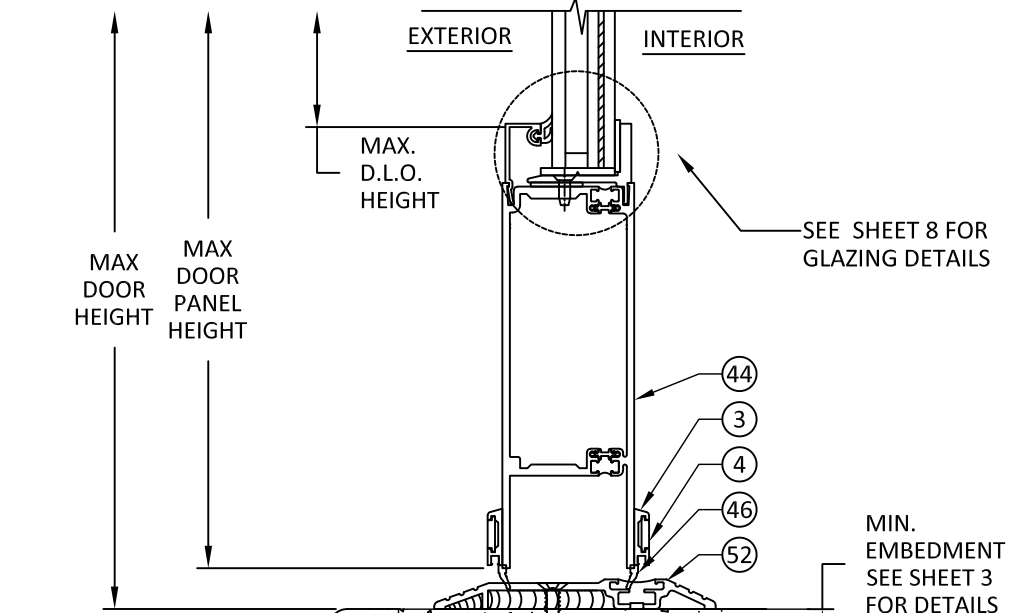

C
4 VERTICAL SECTION
500T DOOR & TRIFAB 451T SUBFRAME
SILL - CONCRETE/MASONRY

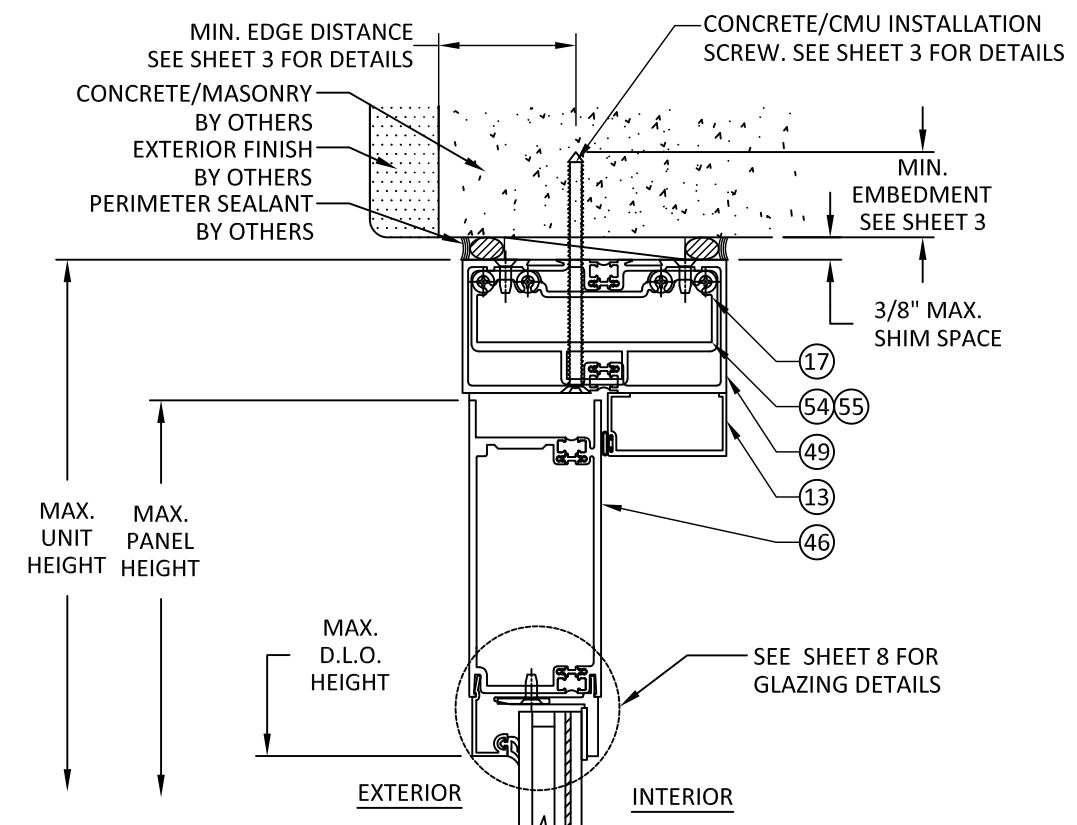

B
4 VERTICAL SECTION
500T DOOR & TRIFAB 451T SUBFRAME
HEAD-CONCRETE/CMU

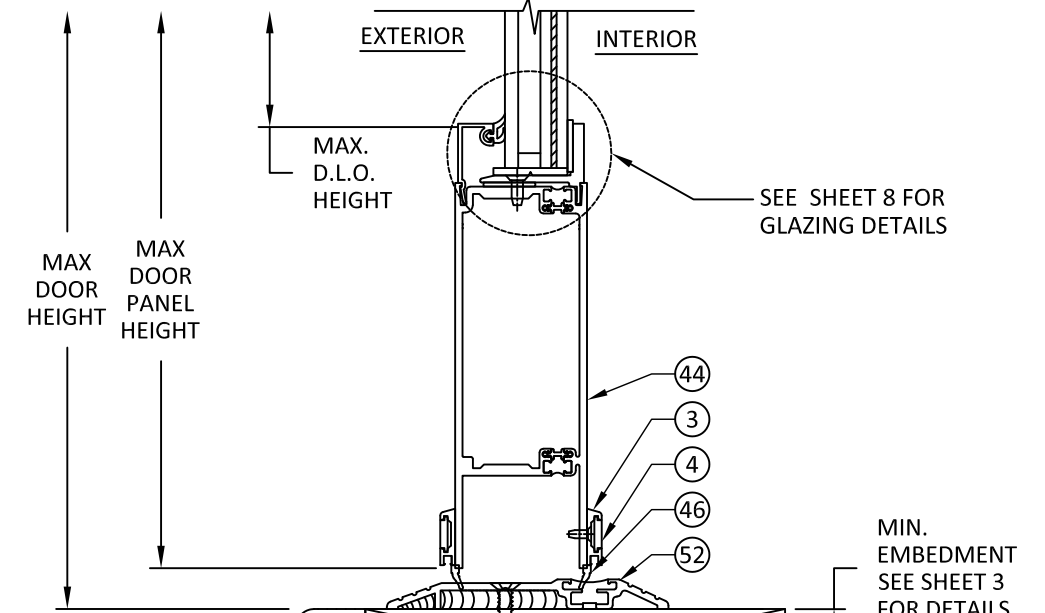

D
4 VERTICAL SECTION
500T DOOR & TRIFAB 451T SUBFRAME
SILL-2X WOOD FRAME

12/8/2021 2:43 PM

s:\projects\kawneer company\tdr-21-0118 -tdf-submittal\dwgs\128914\kaw021.dwg

TITLE: **INSULPOUR 500T THERMAL ENTRANCE (IMPACT)**
VERTICAL SECTION & DETAILS

PREPARED BY: **BUILDING DROPS, INC.**
398 E. DANIA BEACH BLVD., STE. 338
DANIA BEACH, FL 33004
PH: (954) 399-8478
FAX: (954) 744-4738
WEB: www.buildingdrops.com

REMARKS	BY	DATE

THE INSTALLATION DETAILS DESCRIBED HEREIN ARE GENERIC AND MAY NOT REFLECT ACTUAL CONDITIONS FOR A SPECIFIC SITE. IF SITE CONDITIONS CAUSE INSTALLATION TO DEVIATE FROM THE REQUIREMENTS DETAILED HEREIN, A LICENSED ENGINEER OR ARCHITECT SHALL PREPARE SITE SPECIFIC DOCUMENTS FOR USE WITH THIS DOCUMENT



HERMES F. NORERO, P.E.
TEXAS P.E. No 118471
BUILDING DROPS, INC
398 E. DANIA BEACH BLVD. # 338
DANIA BEACH, FL 33004
TBPE FIRM No. 13734

DATE: **02.11.21**
DWG. BY: **ER** CHK. BY: **HFN**
SCALE: **NTS**
DWG. #: **KAW021**
SHEET:

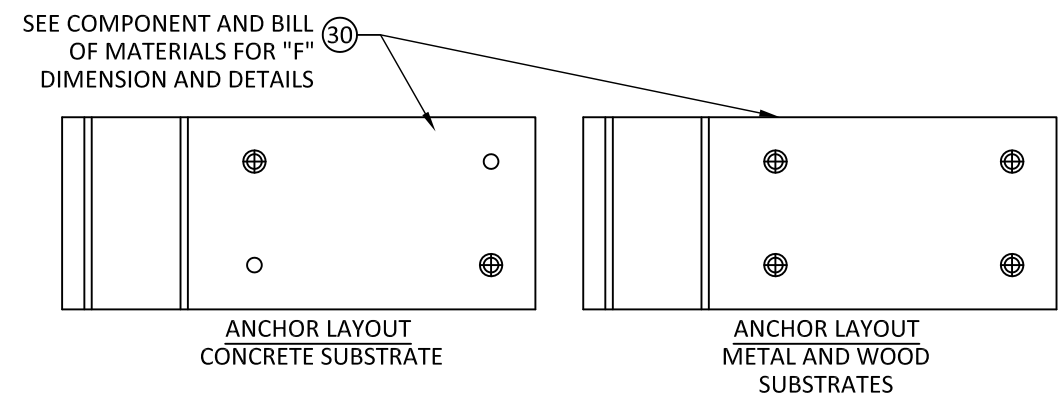

TABLE 4 ANCHOR SCHEDULE FOR "F" CLIP

ANCHOR DESCRIPTION	SUBSTRATE REQUIREMENTS	MIN. EMBEDMENT	MIN. EDGE DISTANCE	NUMBER OF ANCHOR	NOTES
#14 WOOD ANCHOR	MIN. S.G.= 0.42 WOOD	1-1/2"	1-5/8"	4	-
1/4" CONCRETE ANCHOR	CONCRETE F'C=3000 PSI MIN.	2.00"	3.00"	2	ITW TAPCONS
1/4" DIA. SELF-DRILLING ANCHOR (GRADE 5)	STEEL: 12 GA. MIN., Fy=36KSI MIN. ALUM: 1/8" MIN, 6063-T5 MIN	3 THREADS PENETRATION BEYOND METAL STRUCTURE	3/4"	4	STEEL IN CONTACT WITH ALUM. TO BE PLATED OR PAINTED

DETAIL A
"F" CLIP ANCHORS

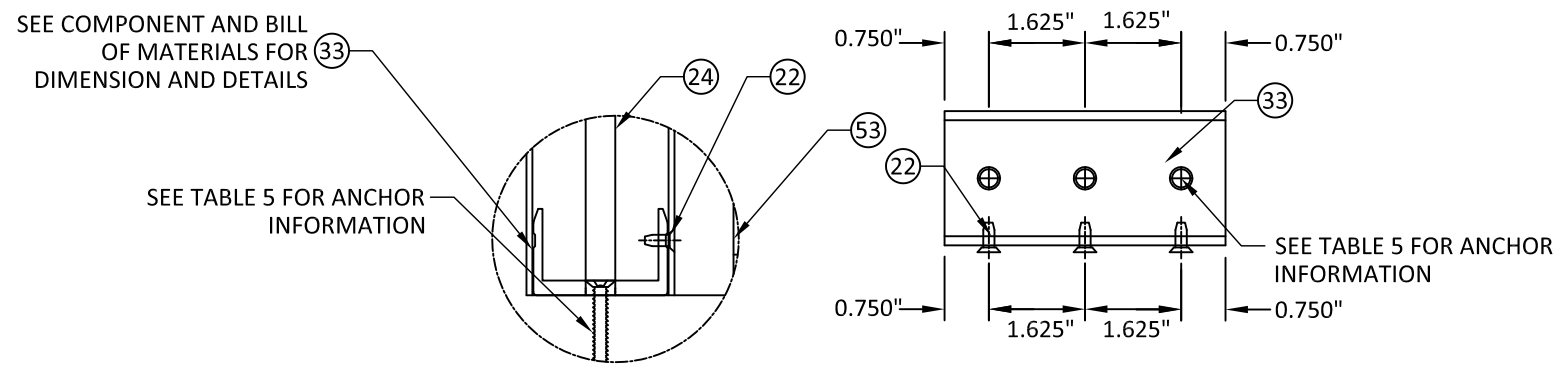
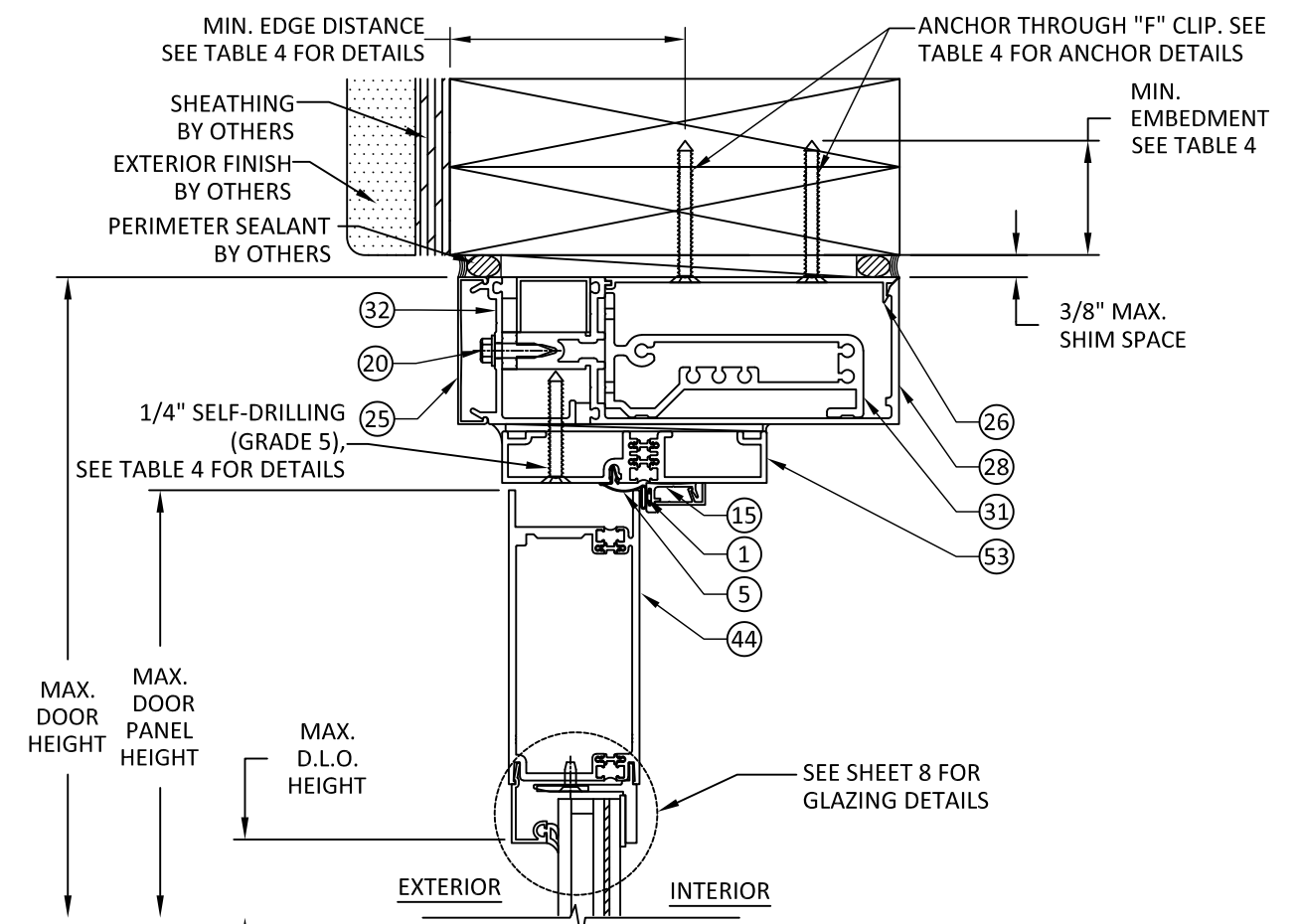

TABLE 5 ANCHOR SCHEDULE FOR 1600 WALL SYSTEM

ANCHOR DESCRIPTION	SUBSTRATE REQUIREMENTS	MIN. EMBEDMENT	MIN. EDGE DISTANCE	NOTES
5/16" WOOD ANCHOR	MIN. S.G.= 0.42 WOOD	1-1/2"	1-5/8"	ELCO ULTRACONS
5/16" CONCRETE ANCHOR	CONCRETE F'C=3000 PSI MIN.	2-1/4"	2-3/16"	ITW TAPCONS
5/16" DIA. SELF-DRILLING ANCHOR (GRADE 5)	STEEL: 12 GA. MIN., Fy=36KSI MIN. ALUM: 1/8" MIN, 6063-T5 MIN	3 THREADS PENETRATION BEYOND METAL STRUCTURE	3/4"	STEEL IN CONTACT WITH ALUM. TO BE PLATED OR PAINTED

DETAIL B
1600 WALL SYSTEM-IMPACT SHEAR BLOCK ANCHOR LAYOUT



A
5
VERTICAL SECTION
500T DOOR & 1600 WALL SYSTEM SILL-2X WOOD FRAME

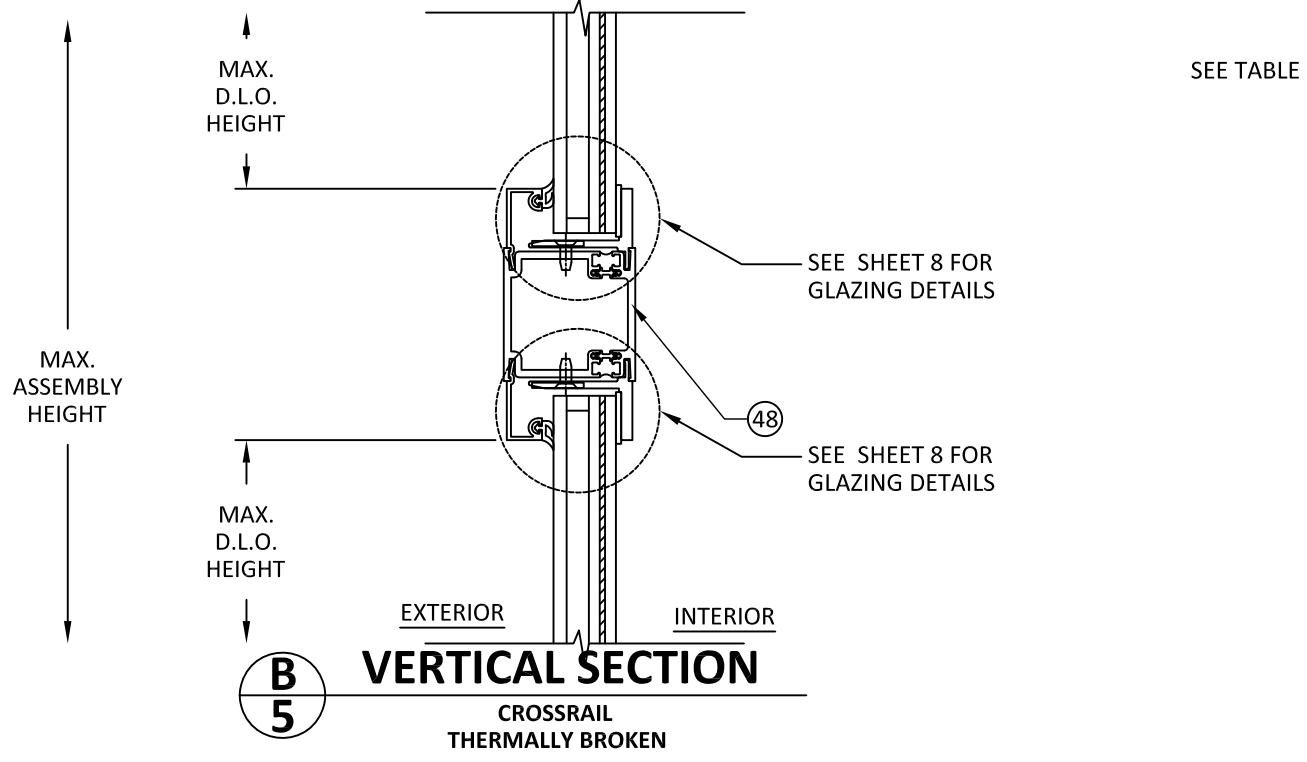

B
5
VERTICAL SECTION
CROSSRAIL THERMALLY BROKEN

s:\projects\kawneer company\tdr-21-0118-rdi-submittal\dwg\128914\kaw021.dwg 12/8/2021 2:43 PM

TITLE: INSULPOUR 500T
THERMAL ENTRANCE
(IMPACT)
HORIZONTAL SECTIONS

PREPARED BY:
BUILDING DROPS, INC.
398 E. DANIA BEACH BLVD., STE. 338
DANIA BEACH, FL 33004
PH: (954) 399-8478
FAX: (954) 744-4738
WEB: www.buildingdrops.com



REMARKS	BY	DATE

THE INSTALLATION DETAILS DESCRIBED HEREIN ARE GENERIC AND MAY NOT REFLECT ACTUAL CONDITIONS FOR A SPECIFIC SITE. IF SITE CONDITIONS CAUSE INSTALLATION TO DEVIATE FROM THE REQUIREMENTS DETAILED HEREIN, A LICENSED ENGINEER OR ARCHITECT SHALL PREPARE SITE SPECIFIC DOCUMENTS FOR USE WITH THIS DOCUMENT



HERMES F. NORERO, P.E.
TEXAS P.E. No 118471
BUILDING DROPS, INC
398 E. DANIA BEACH BLVD. # 338
DANIA BEACH, FL 33004
TBPE FIRM No. 13734

DATE:	02.11.21
DWG. BY:	ER
CHK. BY:	HFN
SCALE:	NTS
DWG. #:	KAW021
SHEET:	6

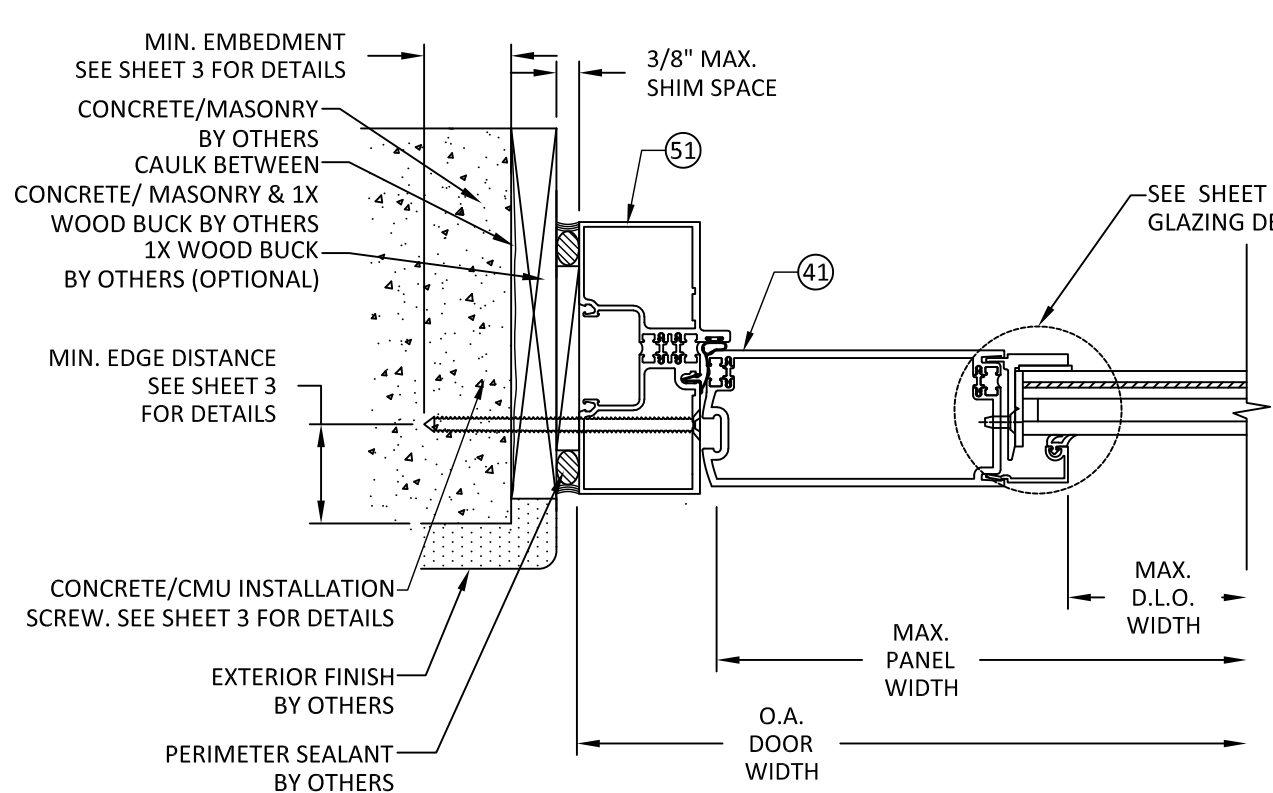

A HORIZONTAL SECTION
6 500T DOOR & TRIFAB 451T SUBFRAME
JAMB-CONCRETE/CMU

INTERIOR

EXTERIOR

*NOTE:
CONTINUOUS HINGE SHOWN
BUTT AND PIVOT HINGE APPROVED
WITH CORRESPONDING STILE.

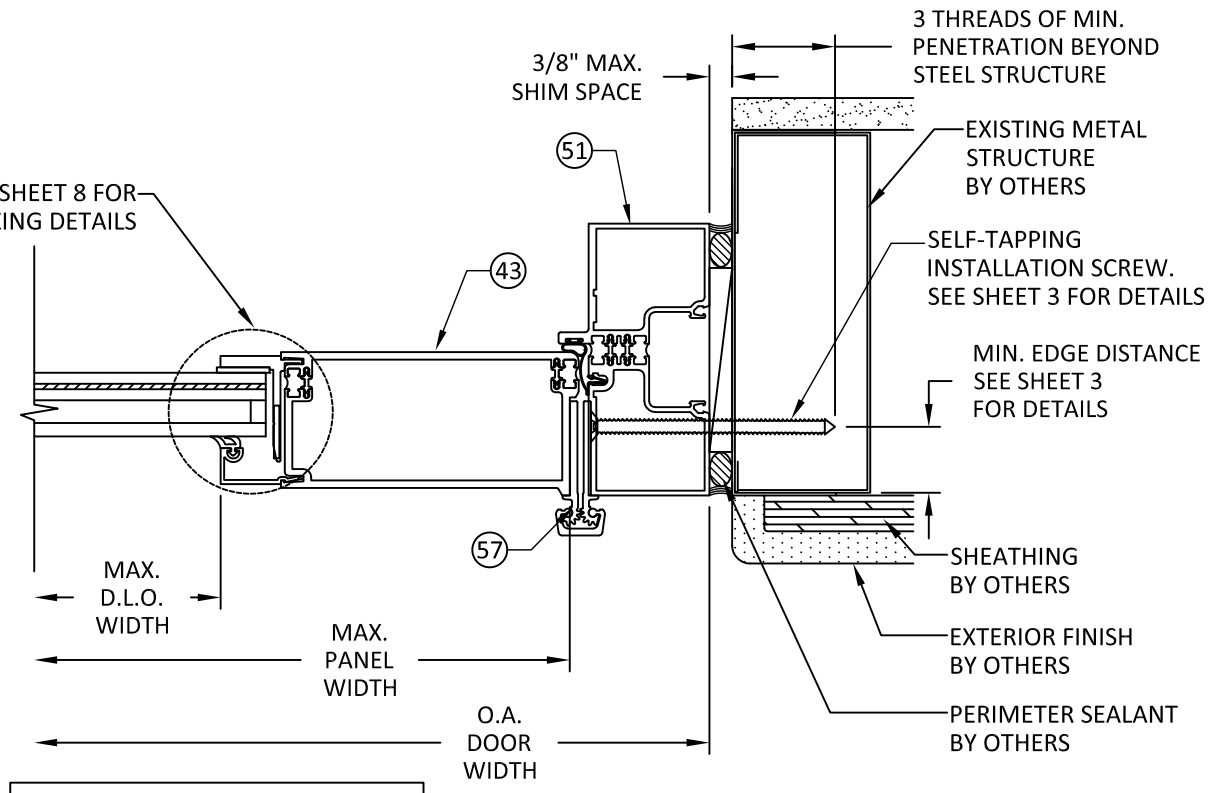

B HORIZONTAL SECTION
7 500T DOOR & TRIFAB 451T SUBFRAME
JAMB-METAL STRUCTURE

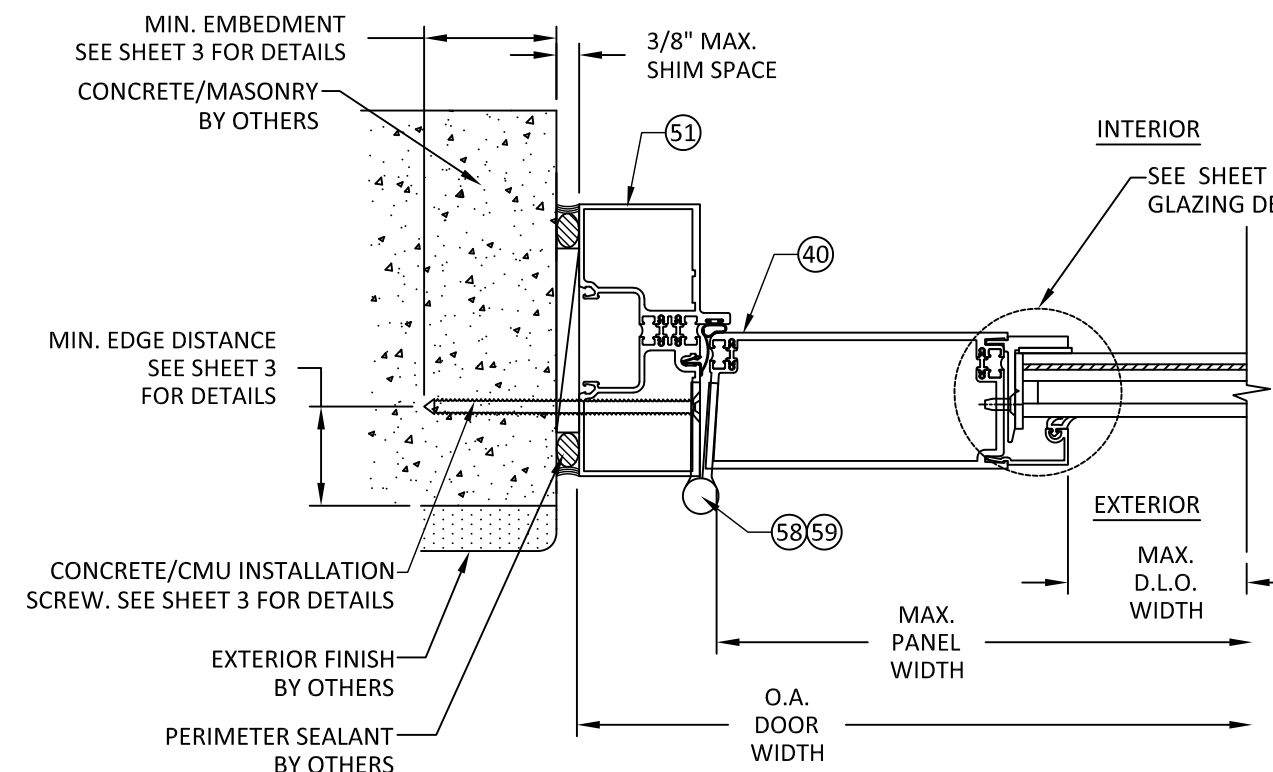

C HORIZONTAL SECTION
6 500T DOOR & TRIFAB 451T SUBFRAME
JAMB-CONCRETE/MASONRY

INTERIOR

EXTERIOR

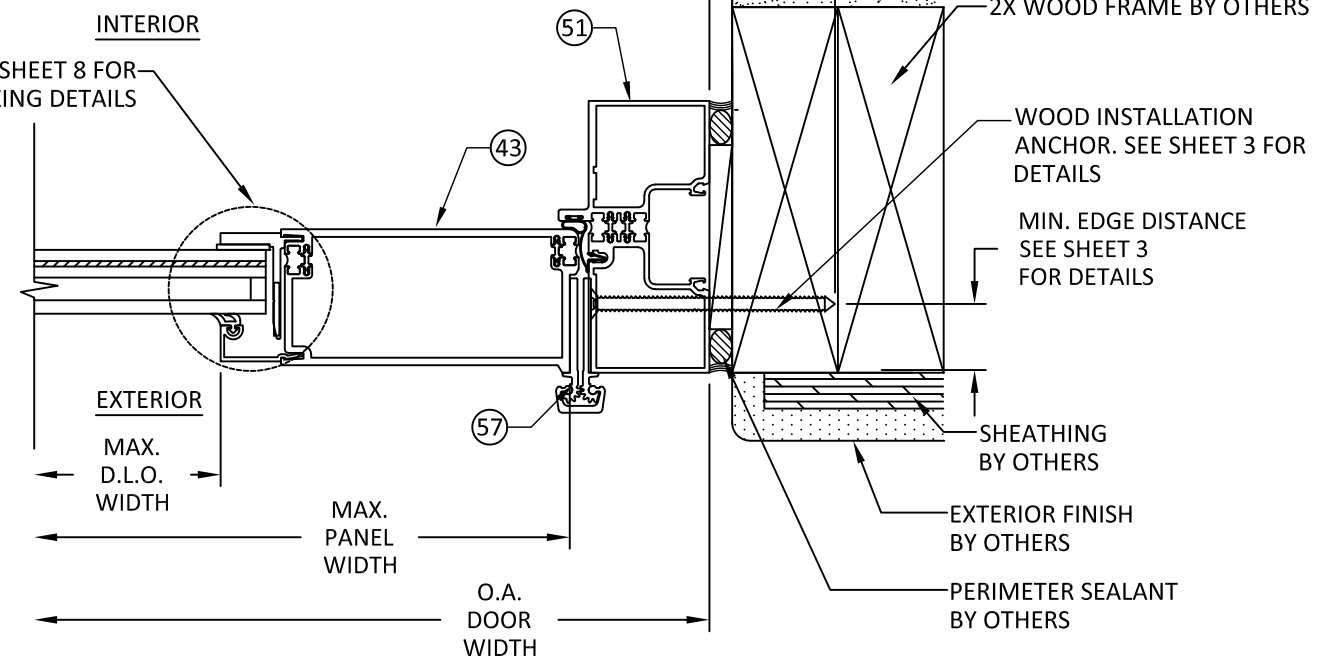

D HORIZONTAL SECTION
6 500T DOOR & TRIFAB 451T SUBFRAME
JAMB-2X WOOD BUCK

INTERIOR

EXTERIOR

12/8/2021 2:43 PM s:\projects\kawneer company\tdr-21-0118 -tdi-submittal\dwgs\128914\kaw021.dwg

TITLE: INSULPOUR 500T
THERMAL ENTRANCE
(IMPACT)
HORIZONTAL SECTIONS

PREPARED BY:
BUILDING DROPS, INC.
398 E. DANIA BEACH BLVD., STE. 338
DANIA BEACH, FL 33004
PH: (954) 399-8478
FAX: (954) 744-4738
WEB: www.buildingdrops.com



REMARKS	BY	DATE

THE INSTALLATION DETAILS DESCRIBED HEREIN ARE GENERIC AND MAY NOT REFLECT ACTUAL CONDITIONS FOR A SPECIFIC SITE. IF SITE CONDITIONS CAUSE INSTALLATION TO DEVIATE FROM THE REQUIREMENTS DETAILED HEREIN, A LICENSED ENGINEER OR ARCHITECT SHALL PREPARE SITE SPECIFIC DOCUMENTS FOR USE WITH THIS DOCUMENT



HERMES F. NORERO, P.E.
TEXAS P.E. No 118471
BUILDING DROPS, INC
398 E. DANIA BEACH BLVD. # 338
DANIA BEACH, FL 33004
TBPE FIRM No. 13734

DATE:	02.11.21
DWG. BY:	ER
CHK. BY:	HFN
SCALE:	NTS
DWG. #:	KAW021
SHEET:	7

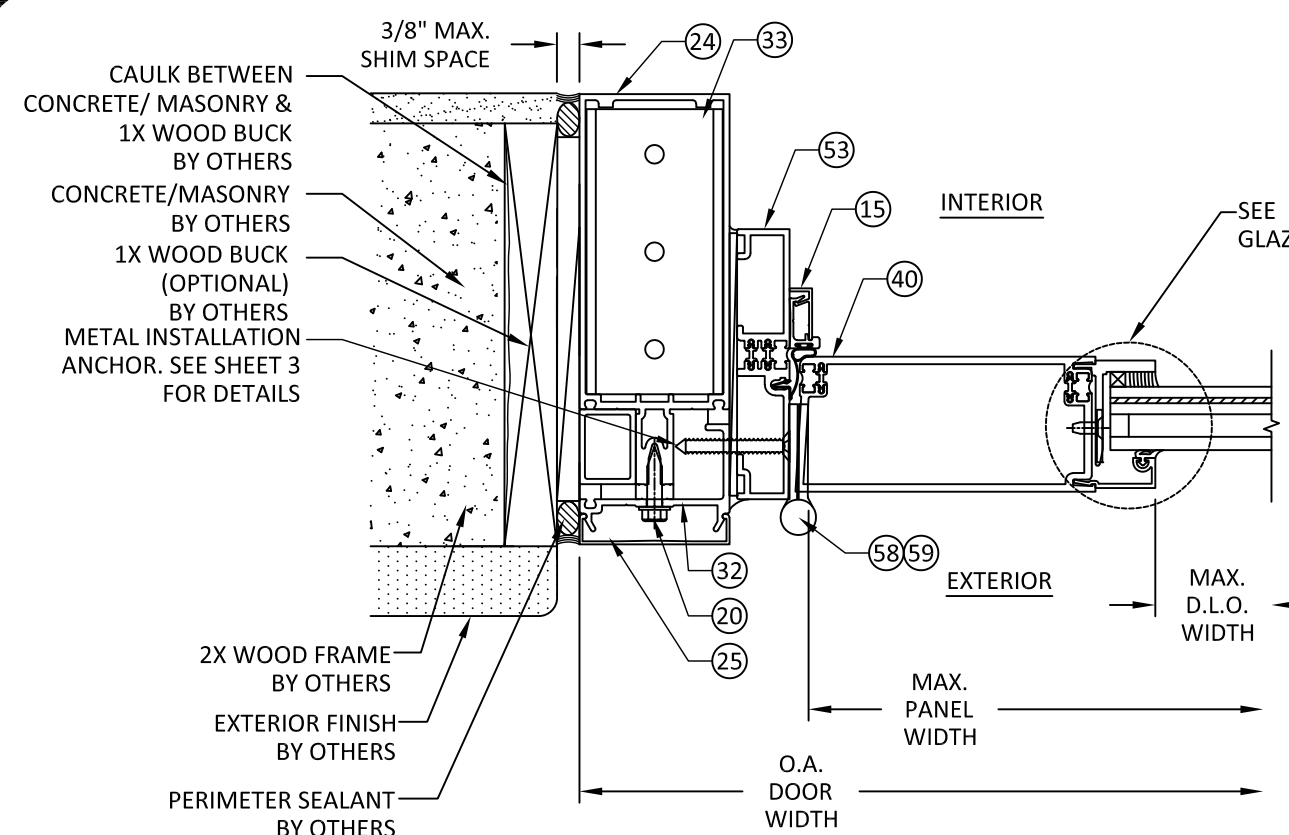

A HORIZONTAL SECTION
7 500T DOOR & 1600 WALL SYSTEM
JAMB

SEE SHEET 8 FOR
GLAZING DETAILS

SEE SHEET 8 FOR
GLAZING DETAILS

*NOTE:
1. CONTINUOUS HINGE SHOWN
BUTT AND PIVOT HINGE APPROVED
WITH CORRESPONDING STILE.
2. ITEM #20 SHOULD SPACED AT
3.0" O.C.

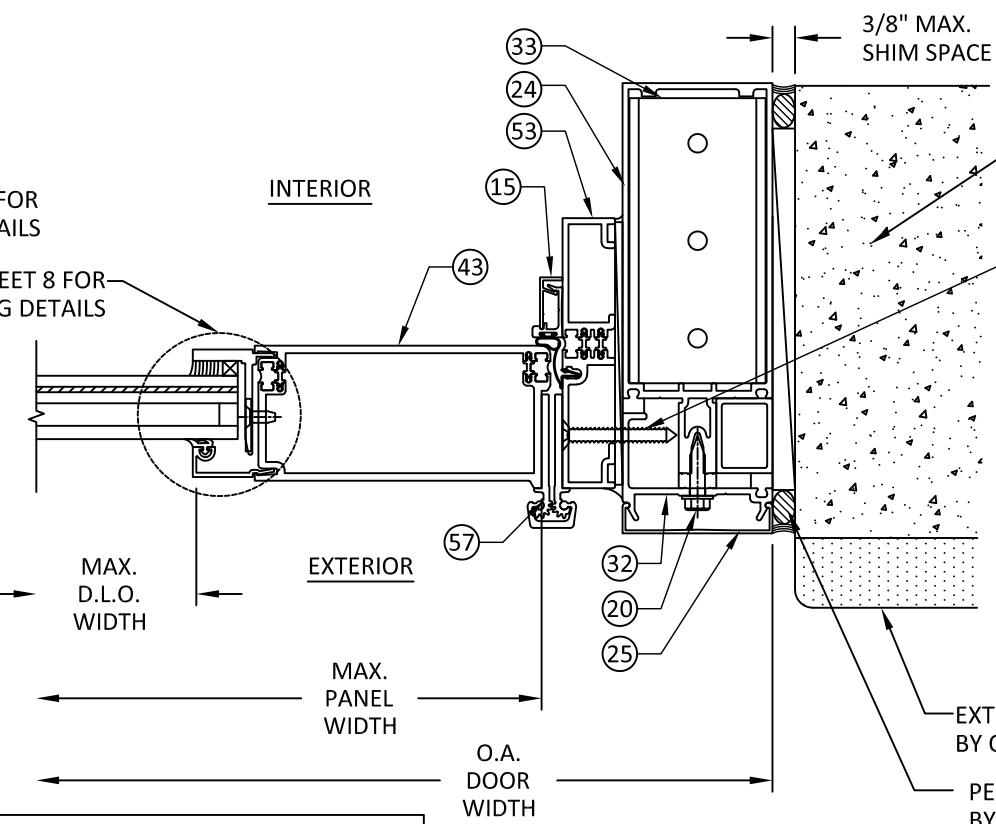

B HORIZONTAL SECTION
6 500T DOOR & 1600 WALL SYSTEM
JAMB

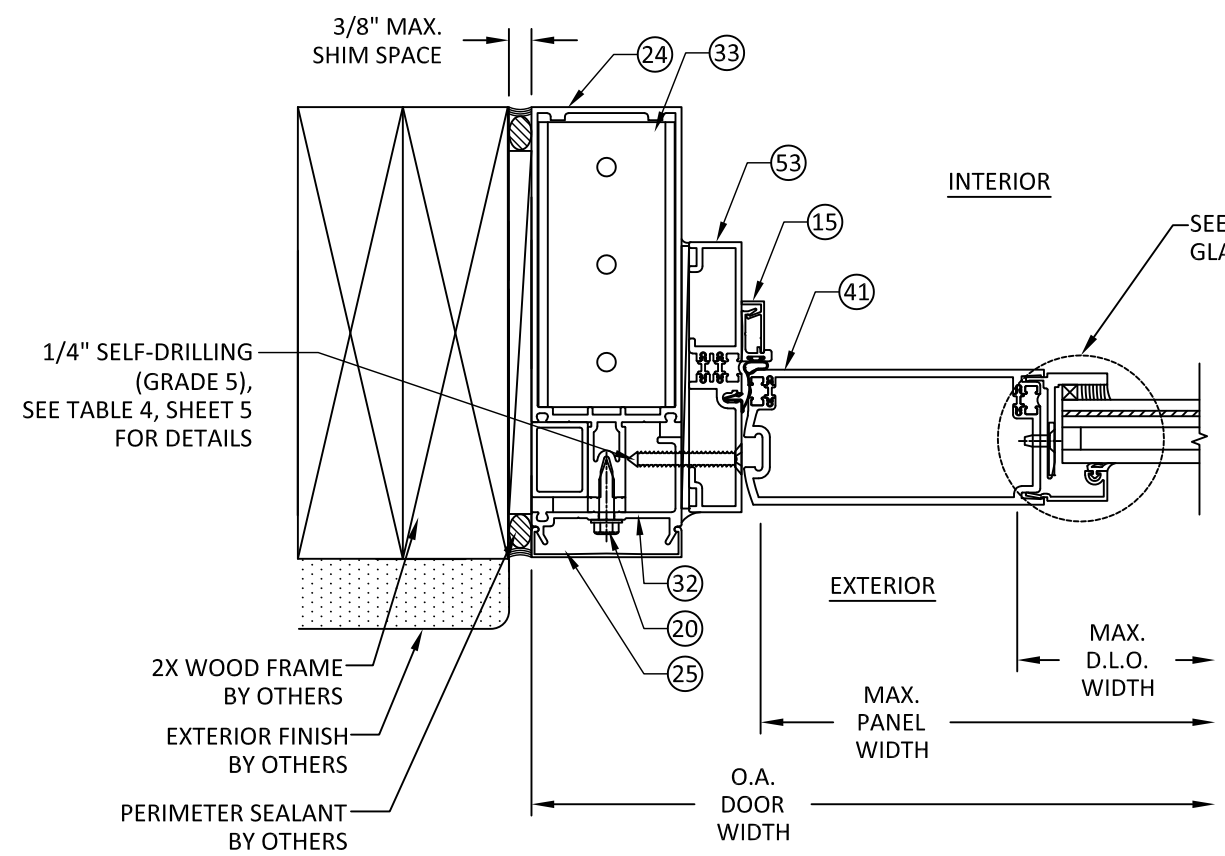

C HORIZONTAL SECTION
7 500T DOOR & 1600 WALL SYSTEM
JAMB

SEE SHEET 8 FOR
GLAZING DETAILS

SEE SHEET 8 FOR
GLAZING DETAILS

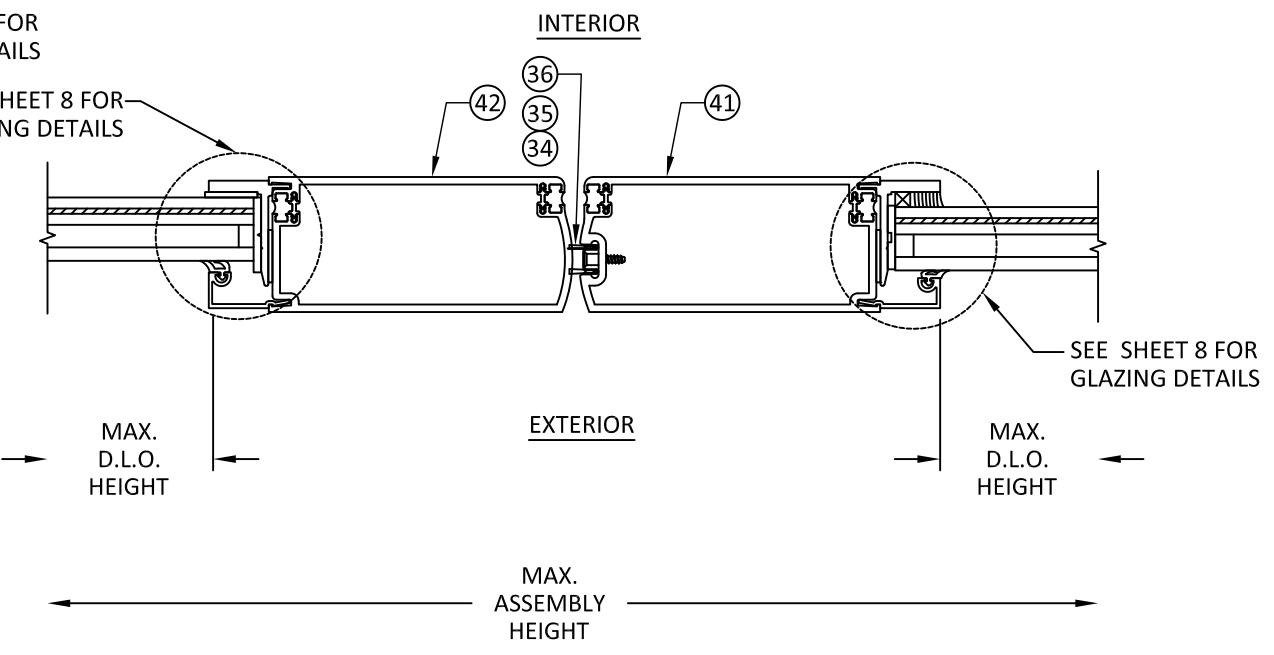

D HORIZONTAL SECTION
7 ASTRAGAL
THERMALLY BROKEN

SEE SHEET 8 FOR
GLAZING DETAILS

12/8/2021 2:43 PM

s:\projects\kawneer company\tdr-21-0118 -tdf-submittal\dwgs\128914\kaw021.dwg

TITLE: **INSULPOUR 500T
THERMAL ENTRANCE
(IMPACT)**
GLAZING DETAILS

PREPARED BY: **BUILDING DROPS, INC.**
398 E. DANIA BEACH BLVD., STE. 338
DANIA BEACH, FL 33004
PH: (954) 399-8478
FAX: (954) 744-4738
WEB: www.buildingdrops.com



REMARKS	BY	DATE

THE INSTALLATION DETAILS DESCRIBED HEREIN ARE GENERIC AND MAY NOT REFLECT ACTUAL CONDITIONS FOR A SPECIFIC SITE. IF SITE CONDITIONS CAUSE INSTALLATION TO DEVIATE FROM THE REQUIREMENTS DETAILED HEREIN, A LICENSED ENGINEER OR ARCHITECT SHALL PREPARE SITE SPECIFIC DOCUMENTS FOR USE WITH THIS DOCUMENT



HERMES F. NORERO, P.E.
TEXAS P.E. No 118471
BUILDING DROPS, INC
398 E. DANIA BEACH BLVD. # 338
DANIA BEACH, FL 33004
TBPE FIRM No. 13734

DATE:	02.11.21	
DWG. BY:	ER	CHK. BY: HFN
SCALE:	NTS	
DWG. #:	KAW021	
SHEET:		

1" IG LAMINATED GLASS CONSISTING OF:
1/4" TEMPERED GLASS
3/8" AIR SPACE
3/16" HEAT STRENGTHENED
0.090" SGP INTERLAYER BY KURARAY
3/16" HEAT STRENGTHENED

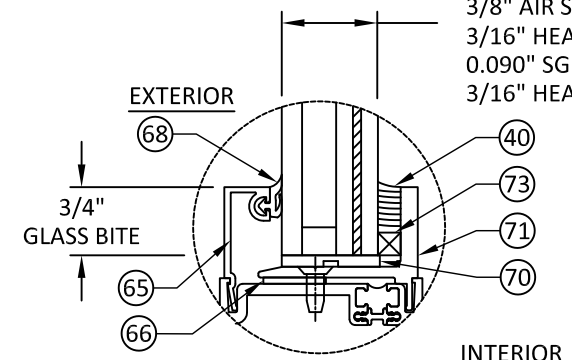

GLAZING DETAIL A
WET GLAZED

1" IG LAMINATED GLASS CONSISTING OF:
1/4" TEMPERED GLASS
3/8" AIR SPACE
3/16" HEAT STRENGTHENED
0.090" SGP INTERLAYER BY KURARAY
3/16" HEAT STRENGTHENED

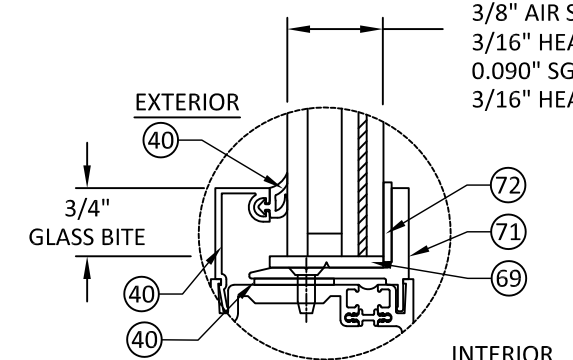

GLAZING DETAIL B
TAPE GLAZED

1" IG LAMINATED GLASS CONSISTING OF:
1/4" TEMPERED GLASS
3/8" AIR SPACE
3/16" HEAT STRENGTHENED
0.090" PVB INTERLAYER BY KURARAY
3/16" HEAT STRENGTHENED

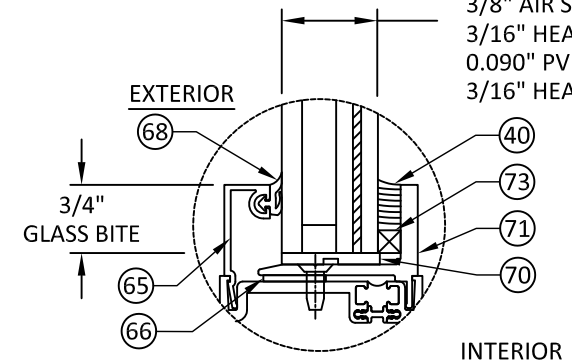

GLAZING DETAIL C
WET GLAZED

1" IG LAMINATED GLASS CONSISTING OF:
1/4" TEMPERED GLASS
3/8" AIR SPACE
3/16" HEAT STRENGTHENED
0.090" PVB INTERLAYER BY KURARAY
3/16" HEAT STRENGTHENED

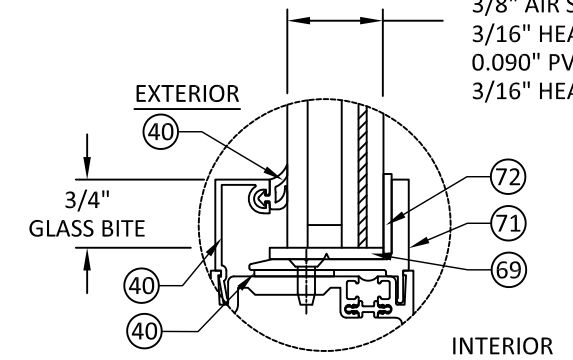

GLAZING DETAIL D
TAPE GLAZED

1" IG LAMINATED GLASS CONSISTING OF:
1/4" TEMPERED GLASS
3/8" AIR SPACE
3/16" HEAT STRENGTHENED
0.090" PVB INTERLAYER BY EASTMAN
3/16" HEAT STRENGTHENED

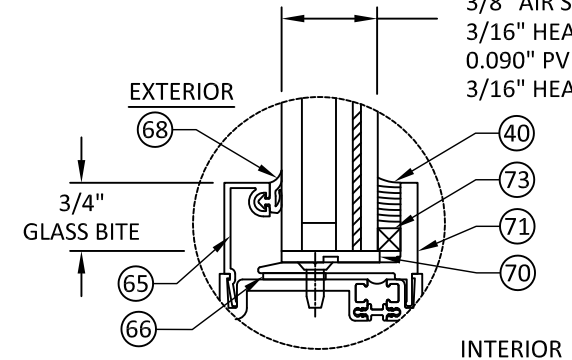

GLAZING DETAIL E
WET GLAZED

1" IG LAMINATED GLASS CONSISTING OF:
1/4" TEMPERED GLASS
3/8" AIR SPACE
3/16" HEAT STRENGTHENED
0.090" PVB INTERLAYER BY EASTMAN
3/16" HEAT STRENGTHENED

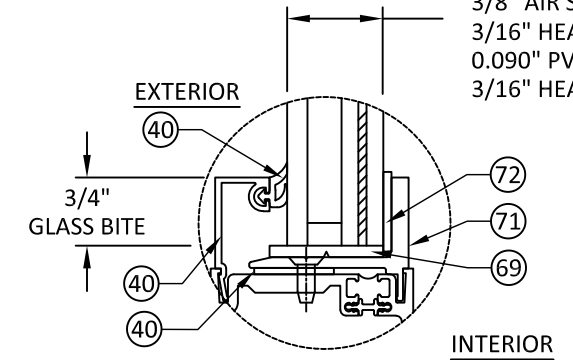

GLAZING DETAIL F
TAPE GLAZED

GLAZING NOTES:
1. GLASS TYPE AND THICKNESS SHALL COMPLY WITH ASTM E1300 REQUIREMENTS AS WELL AS APPLICABLE SAFETY GLAZING REQUIREMENTS PER THE 2018 IBC AND IRC. THICKNESS, TEMPER, AND SAFETY GLAZING REQUIREMENTS SHALL BE REVIEWED ON A SITE SPECIFIC BASIS.

s:\projects\kawneer company\tdr-21-0118 -tdf-submittal\dwgs\128914\kaw021.dwg 12/8/2021 2:44 PM

BILL OF MATERIAL

ID NO.	PART NO.	DESCRIPTION	MATERIAL
1	027078	BULB DOOR WEATHERING	DENSE RUBBER
2	027309	ADJUSTABLE DOOR SWEEP WEATHERING	BLACK EPDM
3	027406	ADJUSTABLE DOOR SWEEP	6063-T6 ALUMINUM
4	027407	ADJUSTABLE DOOR SWEEP FILLER	6063-T6 ALUMINUM
5	027413	THERMAL DOOR WEATHERING	POLYPROPYLENE
6	027857	FIXED GASKET	BLACK EPDM
7	028260	DOOR STOP FASTENER	300 STAINLESS STEEL
8	028315	DOOR SWEEP FASTENER	300 STAINLESS STEEL
9	028336	DOOR STOP FASTENER	300 STAINLESS STEEL
10	028400	SHEAR BLOCK SCREW	300 STAINLESS STEEL
11	028845	THRESHOLD CLIP SCREW	300 STAINLESS STEEL
12	028985	SHEAR BLOCK SCREW	300 STAINLESS STEEL
13	041045	COC STD DOOR STOP	6063-T6 ALUMINUM
14	049896	THRESHOLD TO JAMB CLIP	1010-1020 H.R. STEEL
15	----	-----	-----
16	127251	THERMAL DOOR/FRAME CLIP - 0.210	POLYPROPYLENE
17	128345	SHEAR BLOCK SCREW	300 STAINLESS STEEL
18	128394	SHEAR BLOCK FASTENER	300 STAINLESS STEEL
19	128405	SHEAR BLOCK FASTENER	300 STAINLESS STEEL
20	128406	1/4"-14 X 1" PERIMETER FASTENER	300 STAINLESS STEEL
21	128439	ADJUSTING SCREW FOR ADJUSTABLE ASTRAGAL	CARBON STEEL
22	128910	SHEAR BLOCK SCREW	300 STAINLESS STEEL
23	----	-----	-----
24	162003	VERTICAL/HORIZONTAL MULLION	6063-T6 ALUMINUM
25	162006	EXTERIOR COVER	6063-T6 ALUMINUM
26	162020	OPEN BACK FILLER	6063-T6 ALUMINUM
27	162079	PERIMETER CHANNEL	6063-T6 ALUMINUM
28	162095	OPEN BACK HORIZONTAL	6063-T6 ALUMINUM
29	162310	THERMAL BREAK	BLACK EPDM
30	162311	F ANCHOR	6063-T6 ALUMINUM
31	162332	SHEAR BLOCK	6063-T6 ALUMINUM
32	162505	PRESSURE PLATE	6063-T6 ALUMINUM
33	162545	IMPACT SHEAR BLOCK	6063-T6 ALUMINUM
34	200405	TOP ASTRAGAL	VARIES
35	200406	BOTTOM ASTRAGAL	VARIES
36	200496	ADJUSTABLE ASTRAGAL	VARIES
37	----	-----	-----
38	----	-----	-----
39	----	-----	-----
40	532104	5" DOOR STILE	6063-T6 ALUMINUM
41	532105	5" ACTIVE DOOR STILE	6063-T6 ALUMINUM
42	532106	5" INACTIVE DOOR STILE	6063-T6 ALUMINUM
43	532111	5" CGH DOOR STILE	6063-T6 ALUMINUM
44	532121	6-1/2" BOTTOM RAIL DEEP WEB	6063-T6 ALUMINUM
45	----	-----	-----
46	532123	5.00" TOP RAIL STD. WEB	6063-T6 ALUMINUM
47	----	-----	-----
48	532132	2-1/4" CROSS RAIL	6063-T6 ALUMINUM
49	534101	COC TRANSOM HEAD 451T	6063-T6 ALUMINUM
50	534102	STD. TRANSOM HEAD 451T	6063-T6 ALUMINUM

51	534103	THERMAL DOOR JAMB 451T	6063-T6 ALUMINUM
52	534107	POUR & DEBRIDGE THRESHOLD	6063-T6 ALUMINUM
53	534108	1600 WALL ADAPTER	6063-T6 ALUMINUM
54	534400	COC SHEAR BLOCK OFFSET PIVOT	6063-T6 ALUMINUM
55	534401	COC SHEAR BLOCK BUTT HINGE	6063-T6 ALUMINUM
56	534402	SHEAR BLOCK THERMAL DOOR	6063-T6 ALUMINUM
57	50821	ROTON CONT. GEARED HINGE	VARIES
58	VARIES	RIXSON OFFSET PIVOT SET	VARIES
59	037264	NRP 4-1/2" x 4" BALL BEARING HINGE	VARIES
60	VARIES	FALCON HH1690 CONCEALED ROD EXIT DEVICE	VARIES
61	133571HH	VON DUPRIN HH9947 CVR EXIT DEVICE	VARIES
62	VARIES	1850 MS LOCK SET	VARIES
63	50079	HURRICANE IMPACT FLUSHBOLT	VARIES
64	137705	CLASSIC C09 CP II PUSH/PULL PACKAGE	VARIES
65	575041	GLASS STOP	6063-T6 ALUMINUM
66	127171	3-M VHB STRUCTURAL GLAZING TAPE	-----
67	128910	#10 X 1/2" FHTF SCREW TYPE B	-----
68	27563	WEATHERING	EPDM
69	27907	SETTING BLOCK	DUROMETER
70	027394-SI	SETTING BLOCK	DUROMETER
71	575030	1" THERMAL DR INT GL. STOP	-----
72	200948	GLAZING TAPE PACKAGE ANODIZED	-----
73	127095	1/4" X 1/4" SPACER-NORTON V2200	-----
74	VARIES	KAWNEER 1686 CVR PANIC DEVICE	-----



555 GUTHRIDGE CT
NORCROSS, GA 30092
PH: (770) 840-6431

TITLE: INSULPOUR 500T
THERMAL ENTRANCE
(IMPACT)
BILL OF MATERIALS

PREPARED BY:
BUILDING DROPS, INC.
398 E. DANIA BEACH BLVD., STE. 338
DANIA BEACH, FL 33004
PH: (954) 399-8478
FAX: (954) 744-4738
WEB: www.buildingdrops.com



REMARKS	BY	DATE

THE INSTALLATION DETAILS DESCRIBED HEREIN ARE GENERIC AND MAY NOT REFLECT ACTUAL CONDITIONS FOR A SPECIFIC SITE. IF SITE CONDITIONS CAUSE INSTALLATION TO DEVIATE FROM THE REQUIREMENTS DETAILED HEREIN, A LICENSED ENGINEER OR ARCHITECT SHALL PREPARE SITE SPECIFIC DOCUMENTS FOR USE WITH THIS DOCUMENT



HERMES F. NORERO, P.E.
TEXAS P.E. No 118471
BUILDING DROPS, INC
398 E. DANIA BEACH BLVD. # 338
DANIA BEACH, FL 33004
TBPE FIRM No. 13734

DATE:	02.11.21	
DWG. BY:	ER	CHK. BY: HFN
SCALE:	NTS	
DWG. #:	KAW021	
SHEET:	9	

TITLE: **INSULPOUR 500T
THERMAL ENTRANCE
(IMPACT)**
COMPONENTS

PREPARED BY:
BUILDING DROPS, INC.
398 E. DANIA BEACH BLVD., STE. 338
DANIA BEACH, FL 33004
PH: (954) 399-8478
FAX: (954) 744-4738
WEB: www.buildingdrops.com



REMARKS	BY	DATE

THE INSTALLATION DETAILS DESCRIBED HEREIN ARE GENERIC AND MAY NOT REFLECT ACTUAL CONDITIONS FOR A SPECIFIC SITE. IF SITE CONDITIONS CAUSE INSTALLATION TO DEVIATE FROM THE REQUIREMENTS DETAILED HEREIN, A LICENSED ENGINEER OR ARCHITECT SHALL PREPARE SITE SPECIFIC DOCUMENTS FOR USE WITH THIS DOCUMENT



HERMES F. NORERO, P.E.
TEXAS P.E. No 118471
BUILDING DROPS, INC
398 E. DANIA BEACH BLVD. # 338
DANIA BEACH, FL 33004
TBPE FIRM No. 13734

DATE:	02.11.21
DWG. BY:	ER
CHK. BY:	HFN
SCALE:	NTS
DWG. #:	KAW021
SHEET:	10

