

**SGD3130V SMALL MISSILE & LARGE MISSILE
(LEVEL C) IMPACT RESISTANT,
BYPASS & POCKET, 2 & 3 TRACK
SLIDING GLASS DOOR**

DESIGN PRESSURE RATING	RATED FOR SMALL MISSILE & LEVEL C LARGE MISSILE IMPACT RESISTANCE
+/-50.0 PSF	

1) THIS PRODUCT HAS BEEN DESIGNED & TESTED TO COMPLY WITH THE REQUIREMENTS OF THE 2018 INTERNATIONAL BUILDING CODE (IBC) AND THE 2018 INTERNATIONAL RESIDENTIAL CODE (IRC) FOR THE DESIGN PRESSURES LISTED.

2) SHUTTERS ARE NOT REQUIRED WHEN USED IN WIND-BORNE DEBRIS REGIONS AT THE FOLLOWING LOCATIONS:
 A) WITHIN 1 MILE OF THE COASTAL MEAN HIGH WATER LINE WHERE THE ULTIMATE WIND SPEED IS EQUAL TO OR GREATER THAN 130 MPH AND LESS THAN 140 MPH.
 B) GREATER THAN 1 MILE FROM THE COASTAL MEAN HIGH WATER LINE WHERE THE ULTIMATE WIND SPEED IS GREATER THAN OR EQUAL TO 140 MPH AND LESS THAN 150 MPH.

3) MASONRY ANCHORS MAY BE USED INTO WOOD. ALL WOOD BUCKS LESS THAN 1-1/2" THICK ARE TO BE CONSIDERED 1X INSTALLATIONS. 1X WOOD BUCKS ARE OPTIONAL IF UNIT IS INSTALLED DIRECTLY TO SUBSTRATE. WOOD BUCKS DEPICTED AS 2X ARE 1-1/2" THICK OR GREATER. 1X AND 2X BUCKS (WHEN USED) SHALL BE DESIGNED TO PROPERLY TRANSFER LOADS TO THE STRUCTURE. WOOD BUCK DESIGN AND INSTALLATION IS THE RESPONSIBILITY OF THE ENGINEER OR ARCHITECT OF RECORD.

4) ANCHOR EMBEDMENT TO BASE MATERIAL SHALL BE BEYOND WALL DRESSING OR STUCCO. USE ANCHORS OF SUFFICIENT LENGTH. INSTALLATION ANCHORS SHOULD BE SEALED. OVERALL SEALING/FLASHING STRATEGY FOR WATER RESISTANCE OF INSTALLATION SHALL BE DONE BY OTHERS AND IS BEYOND THE SCOPE OF THESE INSTRUCTIONS.

5) SHIMS ARE REQUIRED AT EACH FLANGE ANCHOR LOCATION WHERE THE PRODUCT IS NOT FLUSH TO THE SUBSTRATE. USE SHIMS CAPABLE OF TRANSFERRING APPLIED LOADS. WOOD BUCKS, BY OTHERS, MUST BE SUFFICIENTLY ANCHORED TO RESIST LOADS IMPOSED ON THEM BY THE DOOR.

6) THE ANCHORAGE METHODS SHOWN HAVE BEEN DESIGNED TO RESIST THE WIND LOADS CORRESPONDING TO THE REQUIRED DESIGN PRESSURE. THE 33-1/3% STRESS INCREASE HAS NOT BEEN USED IN THE DESIGN OF THIS PRODUCT. THE 1.6 LOAD DURATION FACTOR WAS USED FOR THE EVALUATION OF ANCHORS INTO WOOD. ANCHORS THAT COME INTO CONTACT WITH OTHER DISSIMILAR MATERIALS SHALL MEET THE REQUIREMENTS OF THE IBC/IRC FOR CORROSION RESISTANCE.

TABLE 2:

Glass Types	
1	1/8" TP Cap, 7/16" Airspace, 3/16" AN, 0.060" Trosifol PVB, 3/16" AN
2	3/16" TP Cap, 3/8" Airspace, 3/16" AN, 0.060" Trosifol PVB, 3/16" AN
3	1/8" TP Cap, 7/16" Airspace, 3/16" HS, 0.060" Trosifol PVB, 3/16" HS
4	3/16" TP Cap, 3/8" Airspace, 3/16" HS, 0.060" Trosifol PVB, 3/16" HS

FIGURE 1:

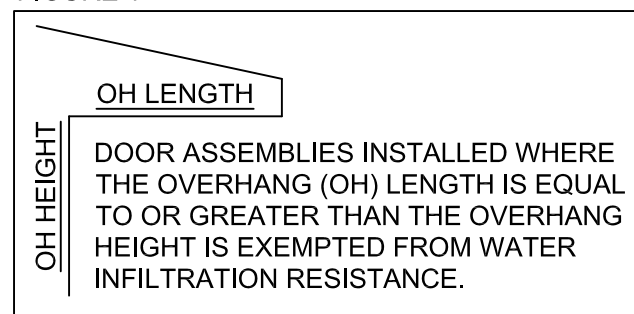

SILL RISER NOTES:

- A) IF WATER INFILTRATION RESISTANCE IS REQUIRED, THE 2-13/16" SILL RISER MUST BE USED.
- B) IF WATER INFILTRATION RESISTANCE IS NOT REQUIRED OR OVERHANG IS PER FIG 1, A SILL RISER IS NOT NEEDED.

TABLE 1: INSTALLATION ANCHORS

Anchor	Location	Substrate	Minimum Edge Distance	Minimum Embedment
#10 or #12 Steel, 18-8 SS or 410 SS Screw	All	Southern Pine (SG = .55)	9/16"	1-3/8"
		Aluminum, 6063-T5 min.	3/8"	0.060"
		Steel Stud, Gr. 33 min.	3/8"	0.045" (18 Ga)
		A36 Steel	3/8"	0.050"
3/16" steel Ultracon+	Head, Sill & Jamb	Concrete (min. 3.0 ksi)	1-1/2"	1-3/4"
	Jamb	Grouted CMU, (ASTM C-90)	1-3/4"	2-1/4"
	Hookstrip	Concrete (min. 3.0 ksi)	1"	1-3/8"
		Grouted CMU, (ASTM C-90)	1"	2-1/4"
1/4" steel Ultracon	Head, Sill & Jamb	Concrete (min. 3.0 ksi)	1"	1-3/8"
	Jamb	UngROUTED CMU, (ASTM C-90)	1-5/8"	1-1/4"
	All	Southern Pine (SG = .55)	1"	1-3/8"
1/4" steel Ultracon	Hookstrip	Concrete (min. 3.0 ksi)	1"	1"
	Hookstrip	UngROUTED CMU, (ASTM C-90)	1"	1-1/4"
1/4" steel Ultracon+	Head, Sill & Jamb	Concrete (min. 3.0 ksi)	1-1/4"	1-3/8"
	Jamb	Grouted CMU, (ASTM C-90)	1"	1-3/4"
	Jamb	UngROUTED CMU, (ASTM C-90)	1-1/2"	1-1/4"
	All	Southern Pine (SG = .55)	1"	1-3/8"
1/4" steel Ultracon+	Hookstrip	Concrete (min. 3.0 ksi)	1"	1"
	Hookstrip	UngROUTED CMU, (ASTM C-90)	1"	1-1/4"

1) CONCRETE ANCHOR LOCATIONS NOTED AS "MAX. ON CENTER" MUST BE ADJUSTED TO MAINTAIN THE MINIMUM EDGE DISTANCE TO MORTOR JOINTS, ADDITIONAL CONCRETE ANCHORS MAY BE REQUIRED TO ENSURE THE "MAX. ON CENTER" DIMENSION IS NOT EXCEEDED. "UNGROUTED CMU" VALUES MAY BE USED FOR GROUTED CMU APPLICATIONS.

2) ALL ANCHOR HEAD TYPES ARE APPLICABLE. ANCHORS MUST EXTEND A MINIMUM OF 3 THREADS BEYOND ANY METAL SUBSTRATE.

CERTIFICATION TABLE:

Window Buck Size		Design Pressure		Glazing (see Table 2)	Certification Number
Width	Height	(+) psf	(-) psf		
210"	96"	50.0	50.0	Types 1-4	NI015342

GENERAL NOTES.....	1
ELEVATIONS.....	2
HORIZ. SECTION VIEWS.....	3
VERTICAL SECTION VIEWS.....	4
GLAZING DETAILS.....	4
FRAME ANCHORAGE, 2T.....	5
FRAME ANCHORAGE, 3T.....	6
EXTRUSIONS.....	7
BILL OF MATERIALS.....	7

Title: VINYL SLIDING GLASS DOOR (LM)		Drawn By: JENS ROSOWSKI	
Description: GENERAL NOTES & ANCHOR TYPES			Date: 08/24/21
Revision:		Rev. By:	Rev. Date:
Series/Model: SGD3130V	Scale: NTS	Sheet: 1 OF 7	Drawing No. SGD3130TDI-1

CGI Impact Resistant Windows & Doors
WE'RE STRONGER™

3780 W 104TH STREET
HIALEAH, FL 33018
(305) 593-6590

PREPARED BY A. LYNN MILLER
1070 TECHNOLOGY DRIVE
N. VENICE, FL 34275
(941) 480-1600

COPYRIGHT © 2021
CGI WINDOWS AND DOORS, INC.
LIMITED LICENSE TO MAKE
COPIES FOR PERMITTING.

ANTHONY LYNN MILLER
106954
LICENSED PROFESSIONAL ENGINEER

A. Lynn Miller 8/27/21
A. LYNN MILLER, P.E.
P.E.# 106594

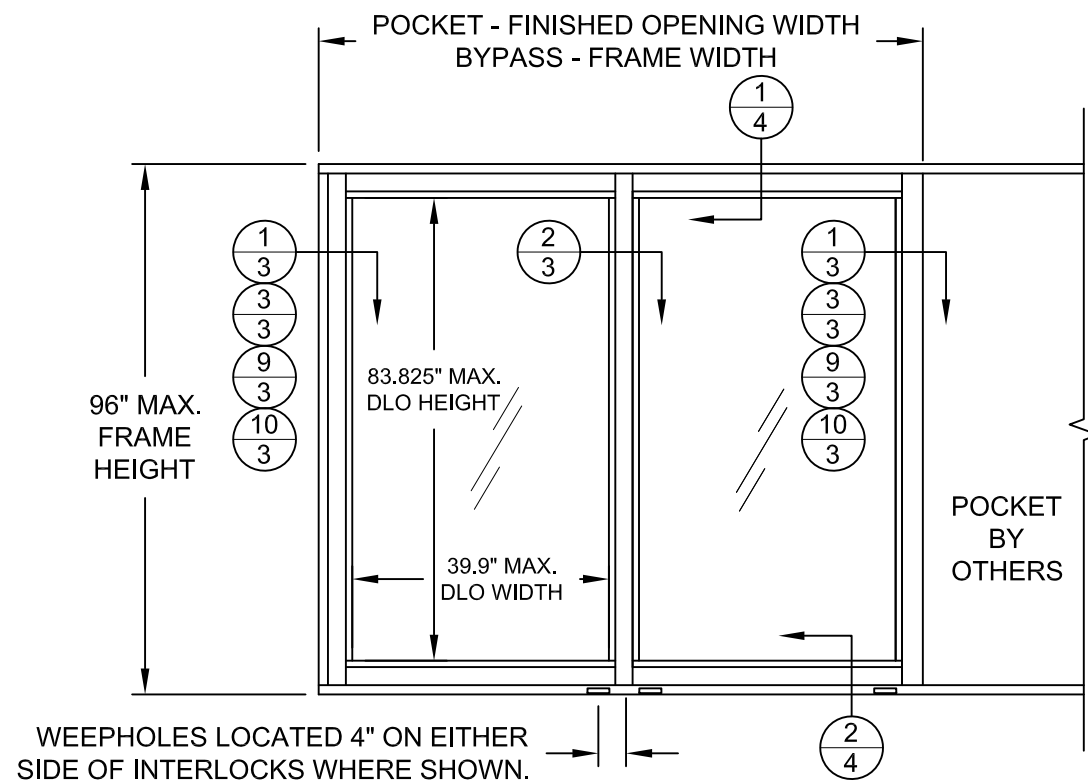

2P2T OX & XO

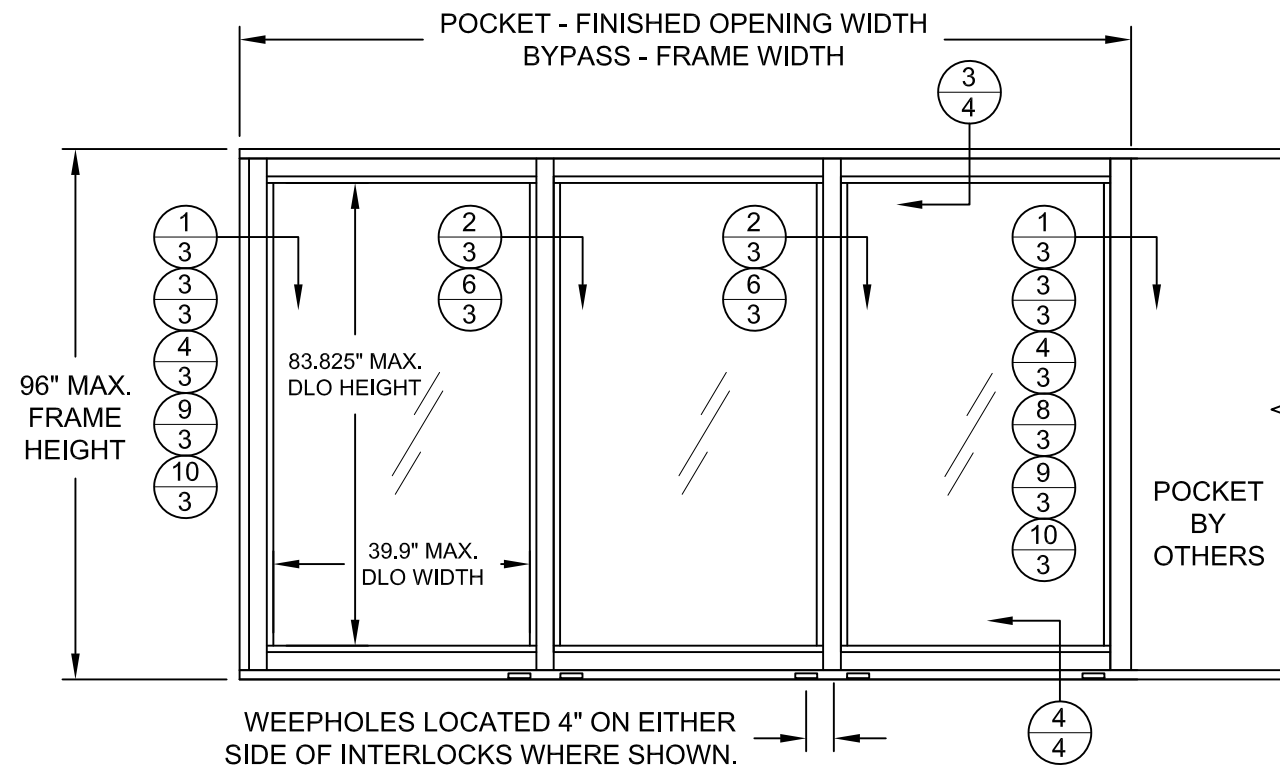

3P2T OXO & 3P3T XXX, XXXP

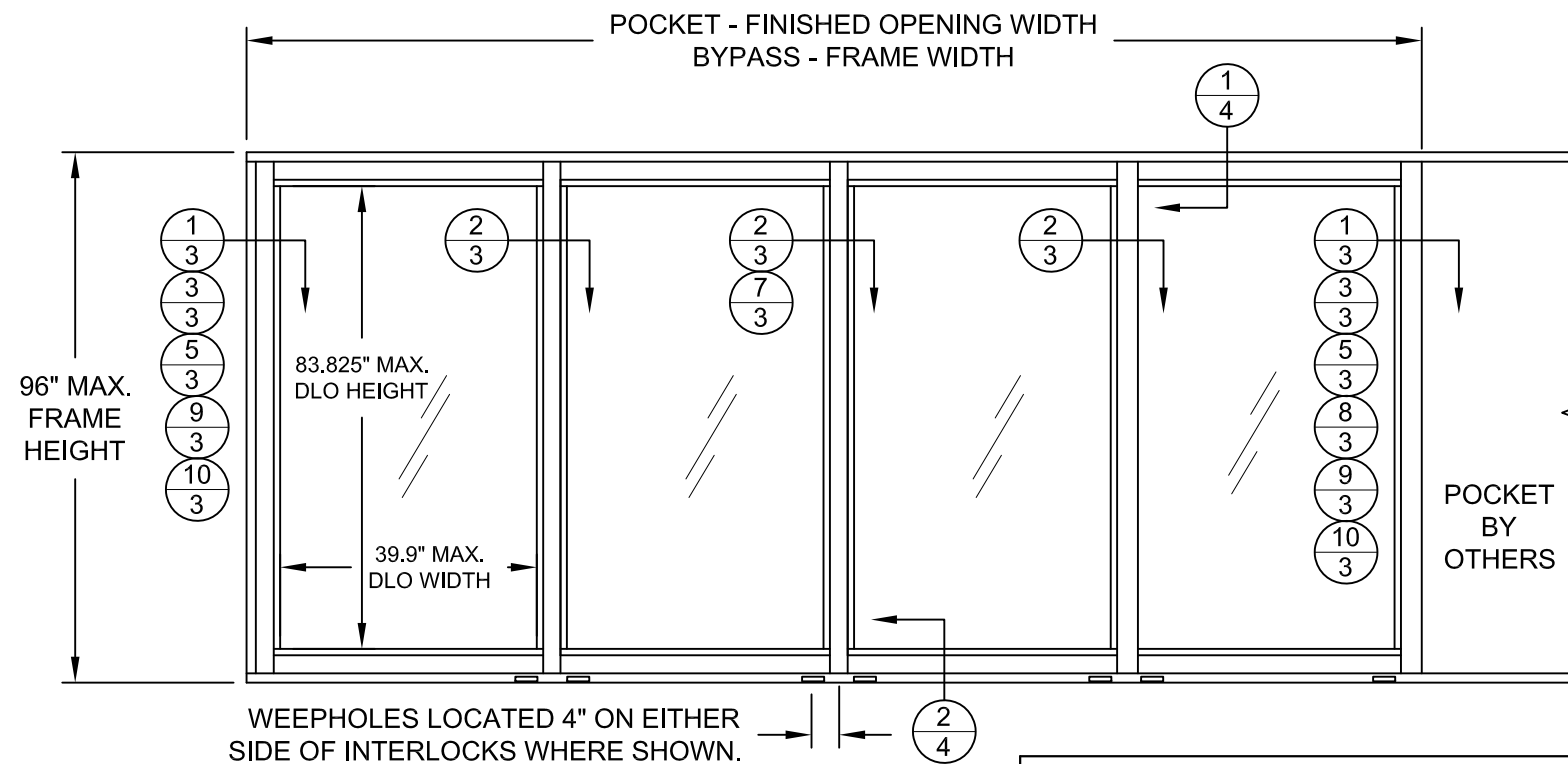

4P2T OXXO

CONFIGURATION NOTES:

- 1) EXTERIOR POCKET CAN BE EITHER LEFT, RIGHT OR DOUBLE.
- 2) POCKET WALL OR CAVITY IS NOT PART OF THIS APPROVAL AND IS TO BE DESIGNED BY OTHERS AND REVIEWED BY THE AUTHORITY HAVING JURISDICTION.
- 3) EXAMPLE CONFIGURATIONS SHOWN. ANY CONFIGURATION IS ACCEPTABLE PROVIDED THAT ONLY THE VERTICAL STILE CONDITIONS SHOWN ON SHEET 3 ARE USED.

Title: VINYL SLIDING GLASS DOOR (LM)		Drawn By: JENS ROSOWSKI	
Description: ELEVATIONS		Date: 08/24/21	
Revision:		Rev. By: Rev. Date:	
Series/Model: SGD3130V	Scale: NTS	Sheet: 2 OF 7	Drawing No.: SGD3130TDI-1
		Rev:	



3780 W 104TH STREET
HIALEAH, FL 33018
(305) 593-6590
PREPARED BY A. LYNN MILLER
1070 TECHNOLOGY DRIVE
N. VENICE, FL 34275
(941) 480-1600

COPYRIGHT © 2021
CGI WINDOWS AND DOORS, INC.
LIMITED LICENSE TO MAKE
COPIES FOR PERMITTING.

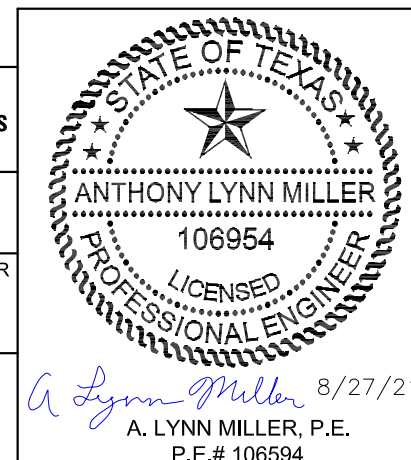

A. Lynn Miller 8/27/21
A. LYNN MILLER, P.E.
P.E.# 106594

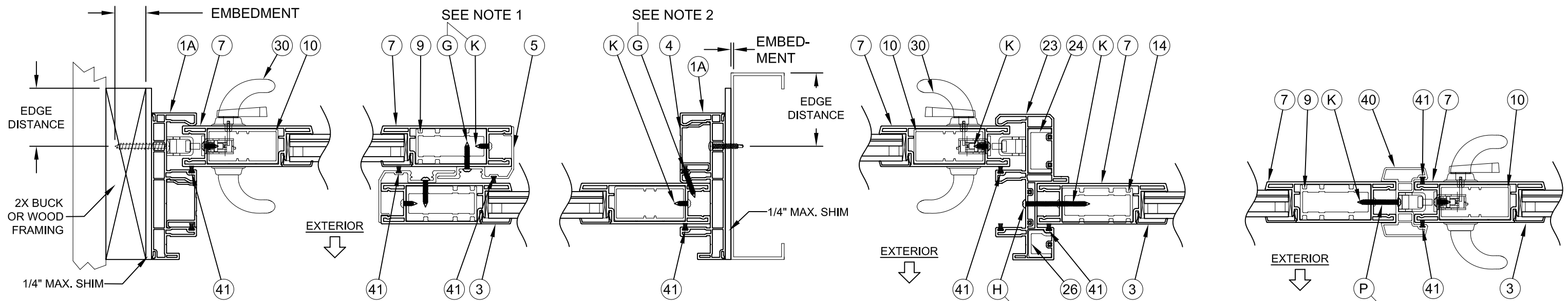

① HORIZONTAL CROSS SECTION
③ 2X BUCK CONSTRUCTION
(SEE NOTES 4 & 5)

② HORIZONTAL CROSS SECTION
③ INTERLOCK

③ HORIZONTAL CROSS SECTION
③ STEEL STUD CONSTRUCTION
(SEE NOTES 4 & 5)

⑥ HORIZONTAL CROSS SECTION
③ MULLION (OFFSET BUTTSTILE)

⑦ HORIZONTAL CROSS SECTION
③ ASTRAGAL

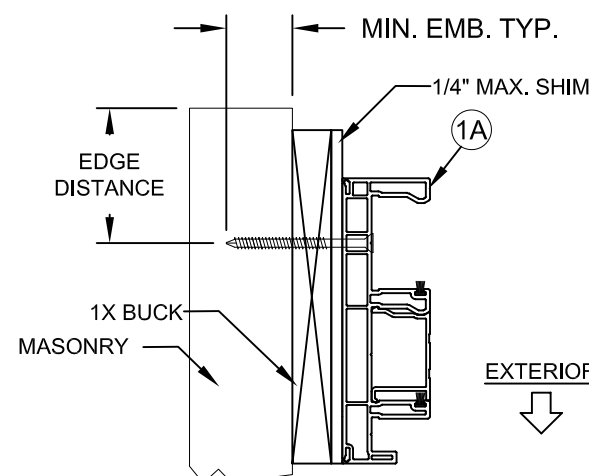

⑨ HORIZONTAL CROSS SECTION
③ 1X BUCK CONSTRUCTION
(SEE NOTES 4 & 5)

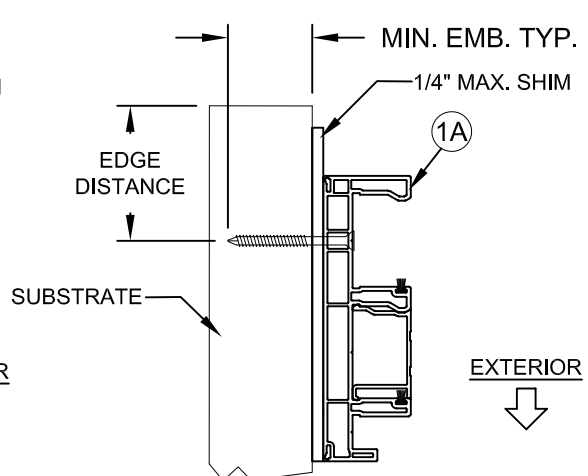

⑩ HORIZONTAL CROSS SECTION
③ MASONRY CONSTRUCTION
(SEE NOTES 4 & 5)

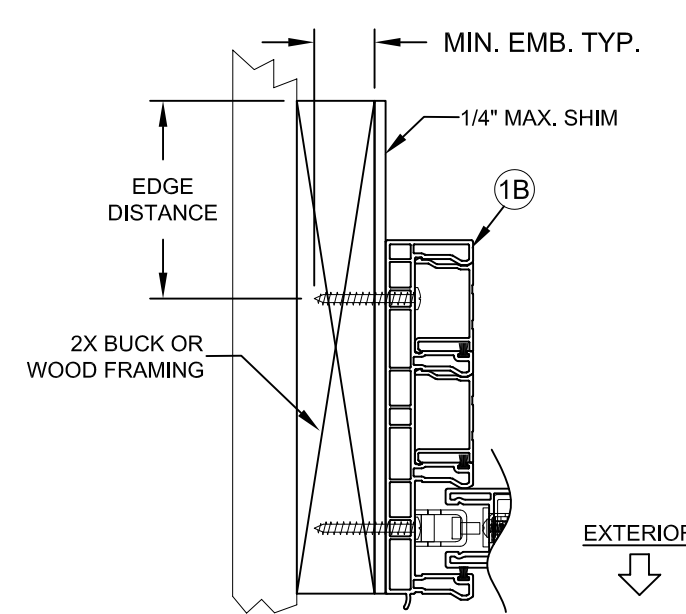

④ HORIZONTAL CROSS SECTION
③ 2X BUCK CONSTRUCTION
(SEE NOTES 4 & 5)

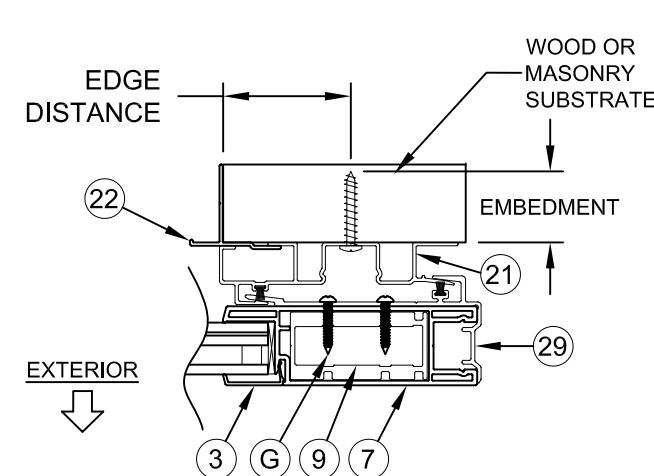

⑧ HORIZONTAL CROSS SECTION
③ HOOKSTRIP
(SEE NOTE 5)

- NOTES:**
- 1) INTERLOCK REINFORCEMENT SCREWS, G & K, ARE LOCATED 3" FROM EACH END THEN 14.5" ON CENTER.
 - 2) FIXED PANEL IN JAMB SCREWS, G, ARE LOCATED 8" FROM EACH END AND THEN 4 MORE EQUALLY SPACED (6 TOTAL)
 - 3) FIXED PANEL IN MULLION SCREWS, H, AND FIXED PANEL IN ASTRAGAL SCREWS, P, ARE LOCATED 6" FROM EACH END AND THEN 12" ON CENTER.
 - 4) ALL ANCHORAGE SUBSTRATE CONDITIONS SHOWN APPLY TO ALL FRAME TYPES.
 - 5) FOR SUBSTRATE & ANCHOR TYPES AND LIMITATIONS, SEE TABLE 1, SHEET1.

Title: VINYL SLIDING GLASS DOOR (LM)		Drawn By: JENS ROSOWSKI	
Description: HORIZONTAL SECTION VIEWS		Date: 08/24/21	
Revision:		Rev. By:	Rev. Date:
Series/Model: SGD3130V	Scale: NTS	Sheet: 3 OF 7	Drawing No. SGD3130TDI-1
		Rev:	

CGI Impact Resistant Windows & Doors
WE'RE STRONGER™

3780 W 104TH STREET
HIALEAH, FL 33018
(305) 593-6590

PREPARED BY A. LYNN MILLER
1070 TECHNOLOGY DRIVE
N. VENICE, FL 34275
(941) 480-1600

COPYRIGHT © 2021
CGI WINDOWS AND DOORS, INC.
LIMITED LICENSE TO MAKE
COPIES FOR PERMITTING.

ANTHONY LYNN MILLER
106954
LICENSED

A Lynn Miller 8/27/21
A. LYNN MILLER, P.E.
P.E.# 106594

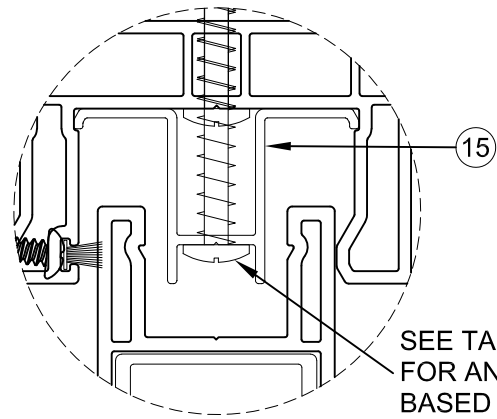

ANTI-LIFT BLOCK DETAIL

SEE TABLE 1 FOR ANCHOR TYPE BASED ON SUBSTRATE

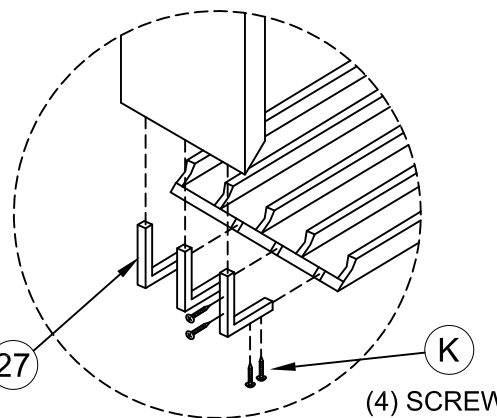

CORNER DETAIL

(4) SCREWS PER CORNER KEY

1 VERTICAL CROSS SECTION
4 1X BUCK CONSTRUCTION (SEE NOTES 3 & 4)

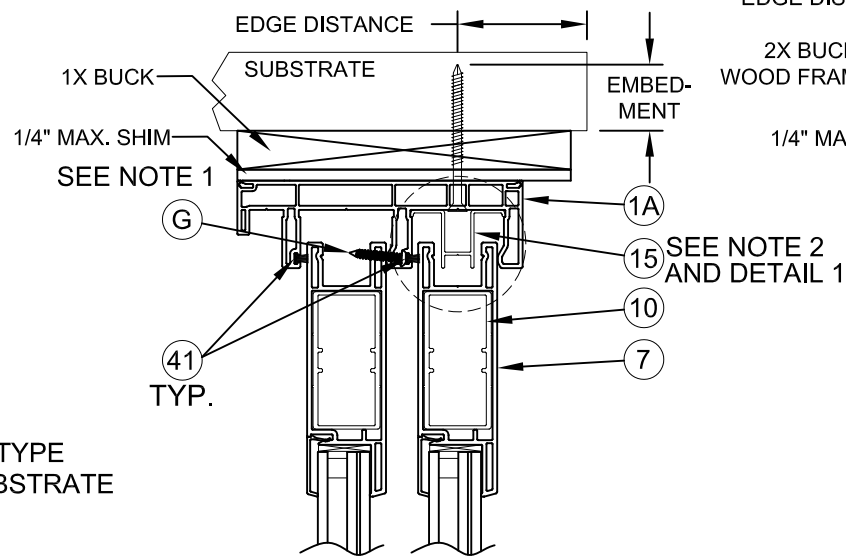

3 VERTICAL CROSS SECTION
4 2X BUCK CONSTRUCTION (SEE NOTES 3 & 4)

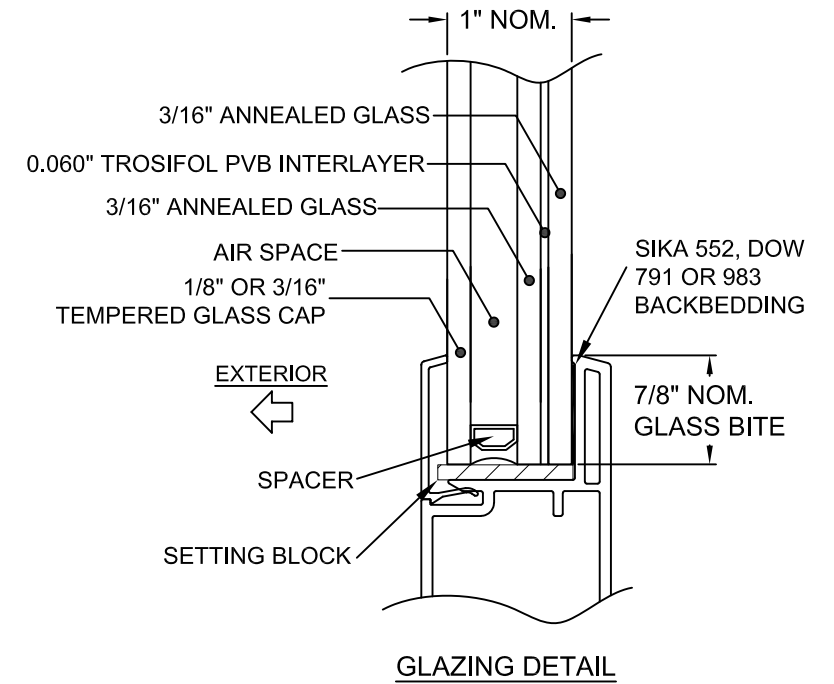
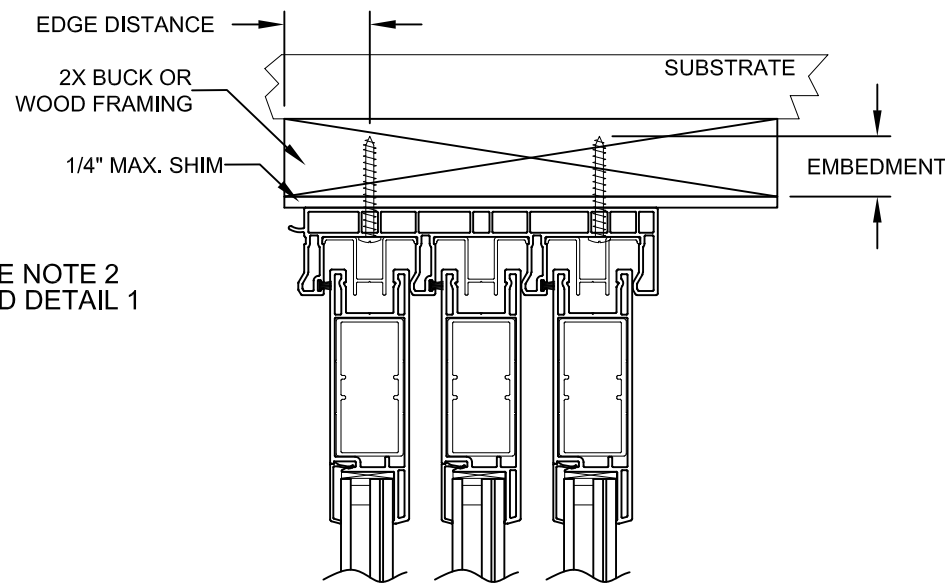

GLAZING DETAIL

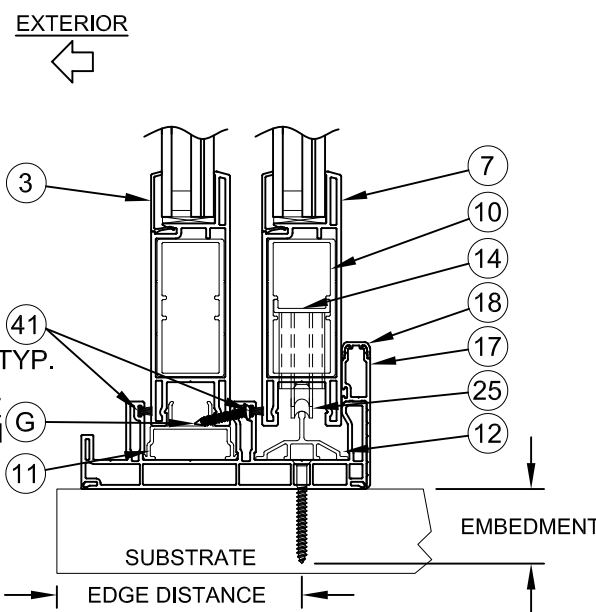

2 VERTICAL CROSS SECTION
4 MASONRY CONSTRUCTION (SEE NOTES 3 & 4)

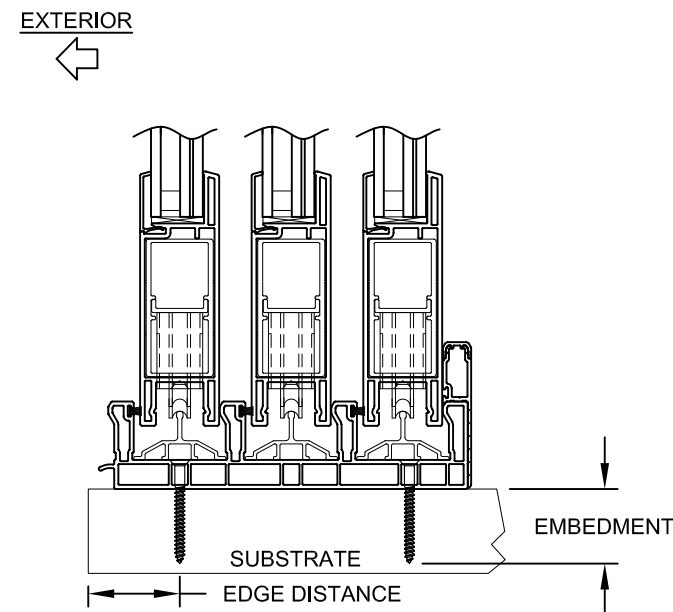

4 VERTICAL CROSS SECTION
4 MASONRY CONSTRUCTION (SEE NOTES 3 & 4)

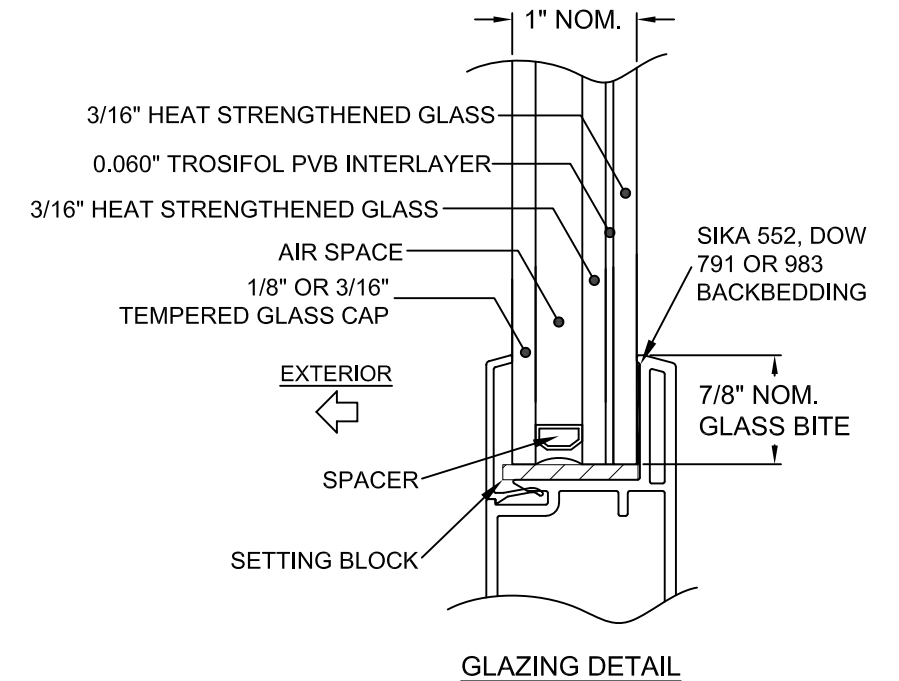

GLAZING DETAIL

NOTES:

- 1) FIXED PANEL SCREW INTO HEAD AND SILL, G, LOCATED 3" AND 6" FROM JAMB AND THEN 6", 9" AND 12" FROM THE INTERLOCK.
- 2) ANCHOR THRU ANTI-LIFT BLOCK (ITEM #15) NOT SHOWN FOR CLARITY. FLAT HEAD ANCHORS MUST BE USED IN SILL, ALL OTHERS INTERFERE WITH ROLLER TRACK.
- 3) FOR SUBSTRATE & ANCHOR TYPES AND LIMITATIONS, SEE TABLE 1, SHEET1.
- 4) ALL ANCHORAGE SUBSTRATE CONDITIONS SHOWN APPLY TO ALL FRAME TYPES.

Title: VINYL SLIDING GLASS DOOR (LM)		Drawn By: JENS ROSOWSKI	
Description: VERT. SECTION VIEWS & GLZ. DETAILS		Date: 08/24/21	
Revision:		Rev. By: Rev. Date:	
Series/Model: SGD3130V	Scale: NTS	Sheet: 4 OF 7	Drawing No. SGD3130TDI-1



3780 W 104TH STREET
HIALEAH, FL 33018
(305) 593-6590
PREPARED BY A. LYNN MILLER
1070 TECHNOLOGY DRIVE
N. VENICE, FL 34275
(941) 480-1600

COPYRIGHT © 2021
CGI WINDOWS AND DOORS, INC.
LIMITED LICENSE TO MAKE
COPIES FOR PERMITTING.



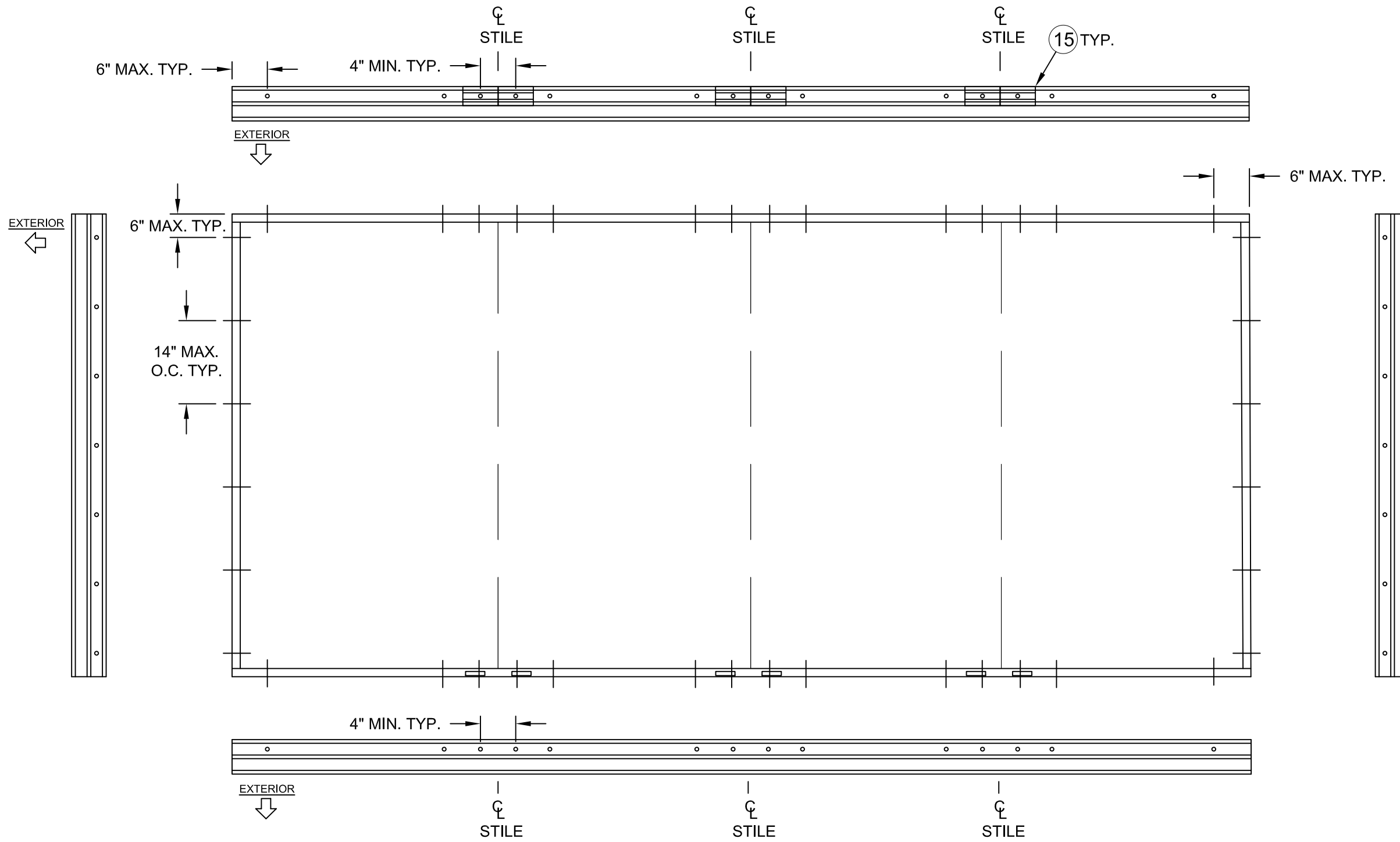

FRAME ANCHORAGE DETAIL
2T BYPASS SLIDING GLASS DOOR
 (SEE SHEET 6 FOR POCKET APPLICATION EXAMPLE)

- NOTES:**
- 1) ANTI-LIFT BLOCKS (ITEM #15) REQ'D ABOVE ALL ACTIVE PANELS (X).
 - 2) OXXO SHOWN, ANCHORAGE SIMILAR FOR OXO, OX AND XO.

Title: VINYL SLIDING GLASS DOOR (LM)		Drawn By: JENS ROSOWSKI	
Description: FRAME ANCHORAGE, 2T		Date: 08/24/21	
Revision:		Rev. By:	Rev. Date:
Series/Model: SGD3130V	Scale: NTS	Sheet: 5 OF 7	Drawing No.: SGD3130TDI-1
		Rev:	

Impact Resistant Windows & Doors
 WE'RE STRONGER™

3780 W 104TH STREET
 HIALEAH, FL 33018
 (305) 593-6590

PREPARED BY A. LYNN MILLER
 1070 TECHNOLOGY DRIVE
 N. VENICE, FL 34275
 (941) 480-1600

COPYRIGHT © 2021
 CGI WINDOWS AND DOORS, INC.
 LIMITED LICENSE TO MAKE
 COPIES FOR PERMITTING.

STATE OF TEXAS
 ANTHONY LYNN MILLER
 106954
 LICENSED PROFESSIONAL ENGINEER

A. Lynn Miller 8/27/21
 A. LYNN MILLER, P.E.
 P.E.# 106594

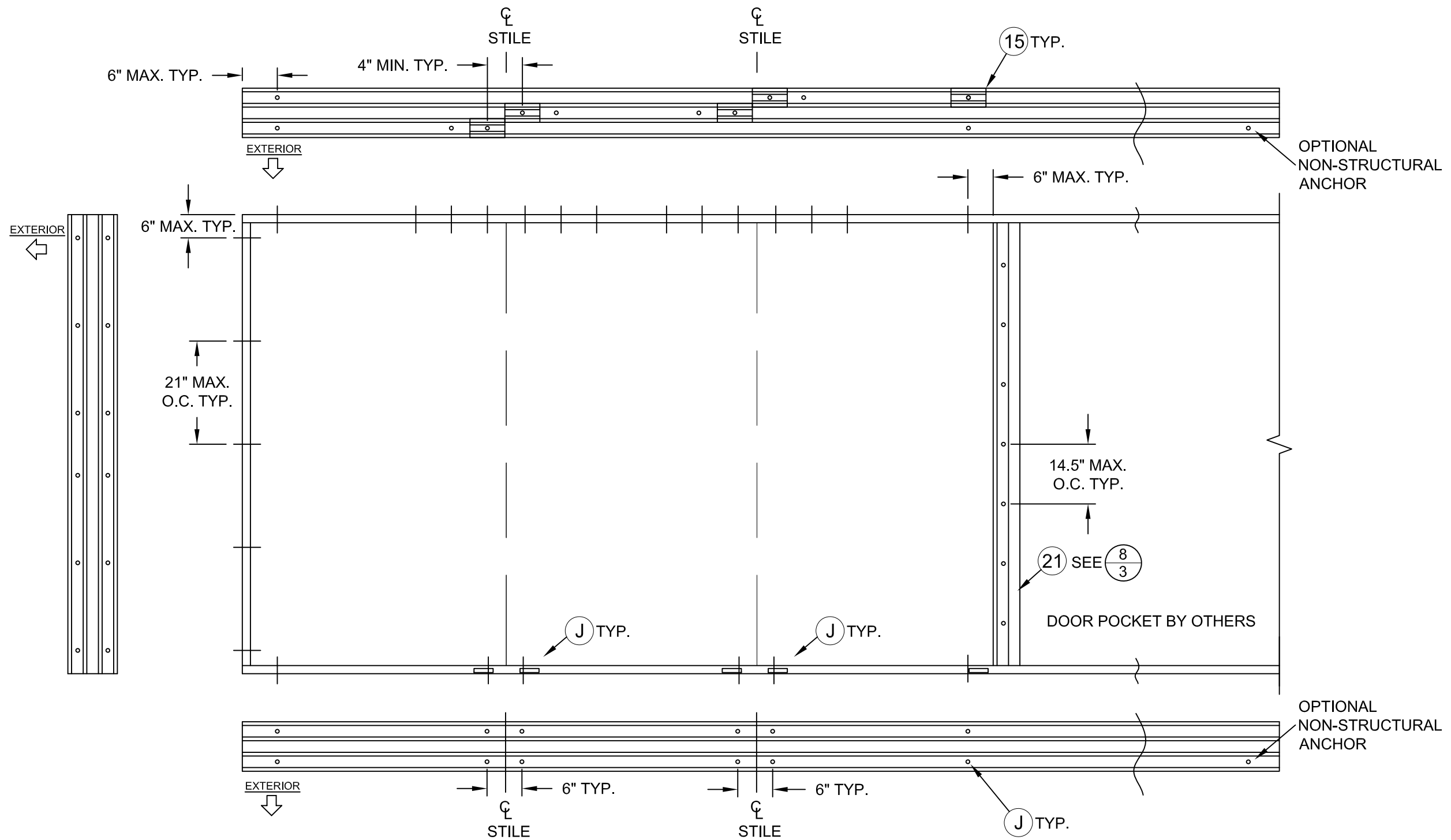

FRAME ANCHORAGE DETAIL
3T SLIDING GLASS 1-POCKET DOOR

NOTES:

- 1) ANTI-LIFT BLOCKS (ITEM #15) REQ'D ABOVE ALL ACTIVE PANELS (X).
- 2) STAGGER ANCHORS ABOUT INTERLOCK CENTERLINES - MIN. 4" O.C., ANCHOR THRU ANTI-LOCK BLOCKS AT HEAD.
- 3) FOR BYPASS ANCHORAGE, DISMISS THE CLUSTERS NEAR THE POCKET (SHOWN ON RIGHT) AND REPLACE WITH END CLUSTERS (SHOWN ON LEFT)

CONFIGURATION NOTES:

- 1) POCKET WALL OR CAVITY IS NOT PART OF THIS APPROVAL AND IS TO BE DESIGNED BY OTHERS AND REVIEWED BY THE AUTHORITY HAVING JURISDICTION.

Title: VINYL SLIDING GLASS DOOR (LM)		Drawn By: JENS ROSOWSKI	
Description: FRAME ANCHORAGE, 3T		Date: 08/24/21	
Revision:		Rev. By:	Rev. Date:
Series/Model: SGD3130V	Scale: NTS	Sheet: 6 OF 7	Drawing No. SGD3130TDI-1
Rev:		Rev:	

Impact Resistant Windows & Doors
CGI WE'RE STRONGER™

3780 W 104TH STREET
 HIALEAH, FL 33018
 (305) 593-6590

PREPARED BY A. LYNN MILLER
 1070 TECHNOLOGY DRIVE
 N. VENICE, FL 34275
 (941) 480-1600

COPYRIGHT © 2021
 CGI WINDOWS AND DOORS, INC.
 LIMITED LICENSE TO MAKE
 COPIES FOR PERMITTING.

STATE OF TEXAS

★ ANTHONY LYNN MILLER ★

106954

LICENSED PROFESSIONAL ENGINEER

A. Lynn Miller 8/27/21
 A. LYNN MILLER, P.E.
 P.E.# 106594

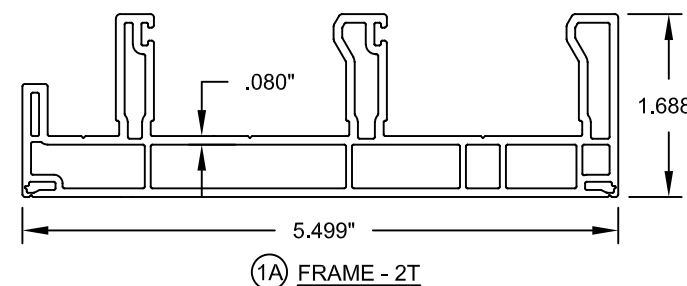

1A FRAME - 2T

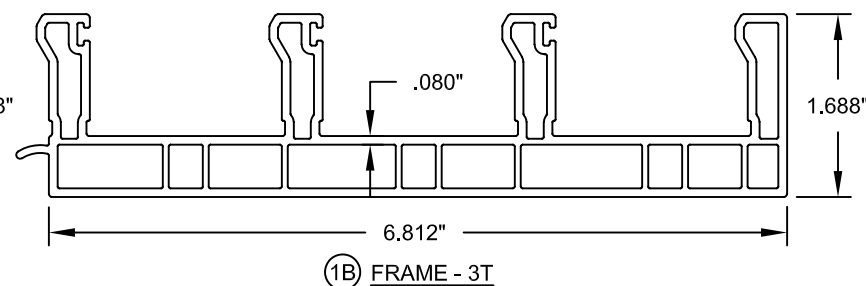

1B FRAME - 3T

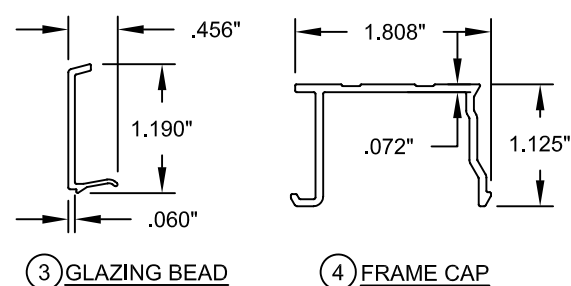

3 GLAZING BEAD

4 FRAME CAP

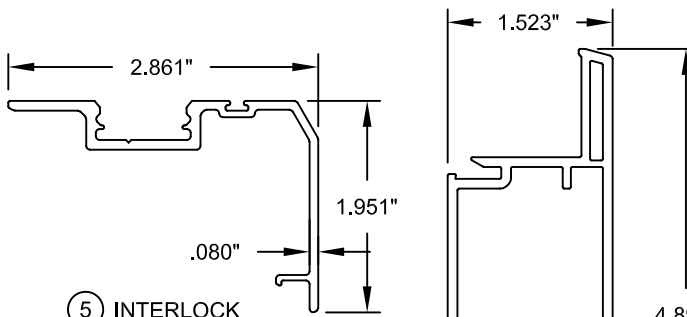

5 INTERLOCK

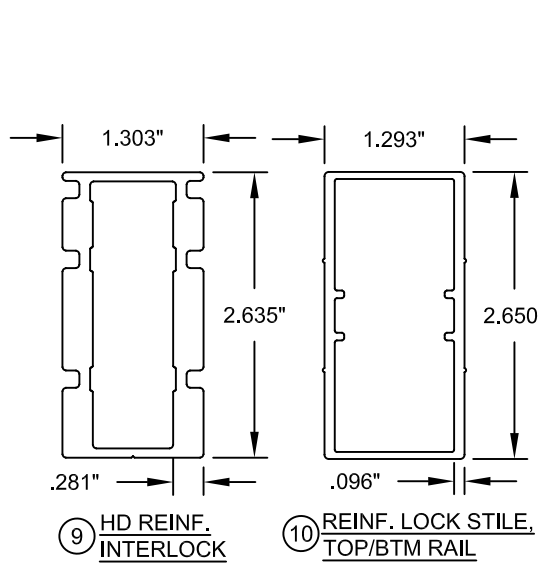

9 HD REINF. INTERLOCK

10 REINF. LOCK STILE, TOP/BTM RAIL

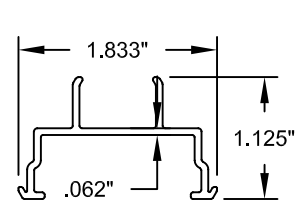

11 FIXED PANEL SUPPORT

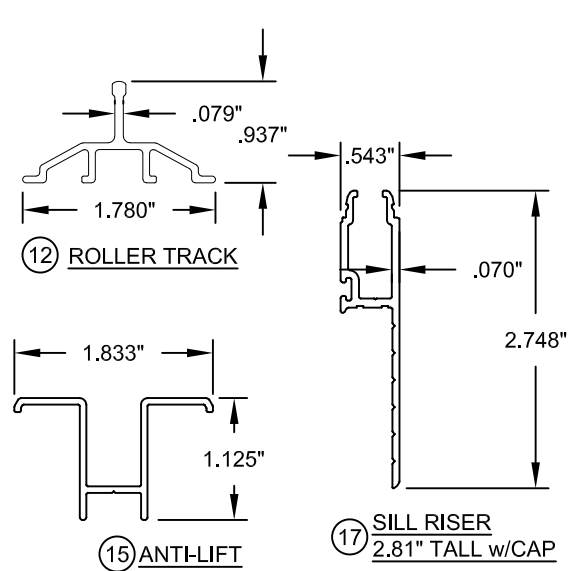

12 ROLLER TRACK

15 ANTI-LIFT

17 SILL RISER 2.81" TALL w/CAP

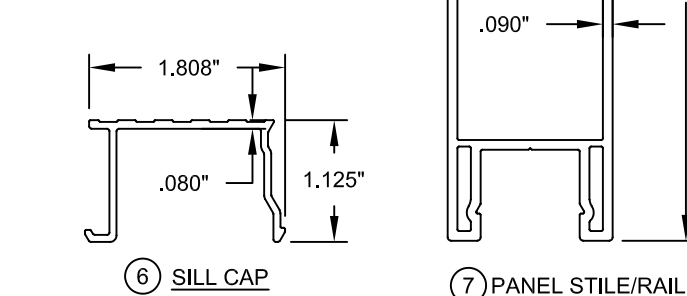

6 SILL CAP

7 PANEL STILE/RAIL

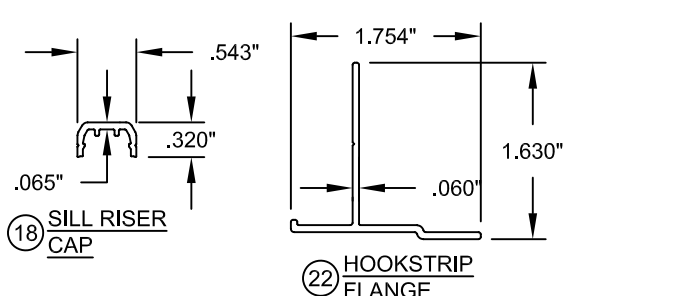

18 SILL RISER CAP

22 HOOKSTRIP FLANGE

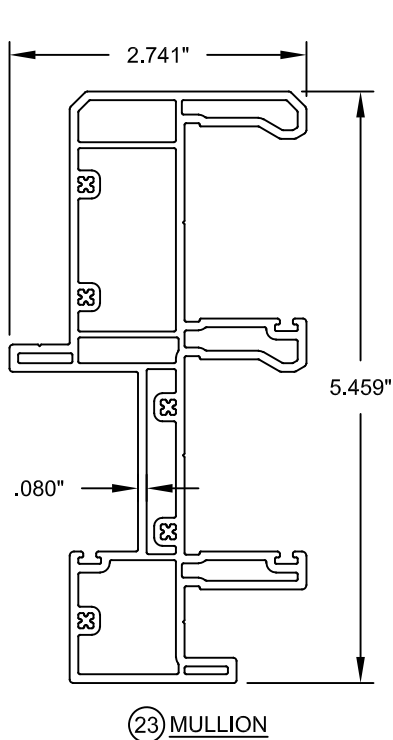

23 MULLION

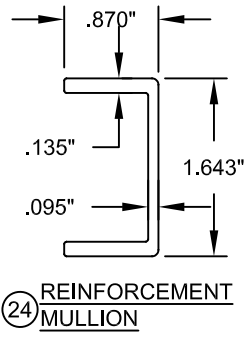

24 REINFORCEMENT MULLION

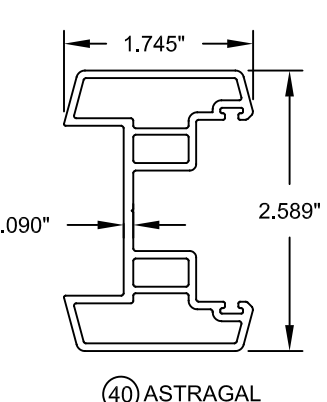

40 ASTRAGAL

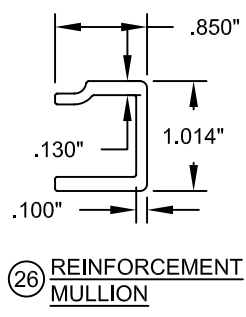

26 REINFORCEMENT MULLION

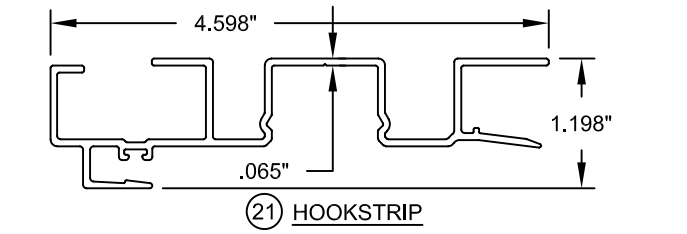

21 HOOKSTRIP

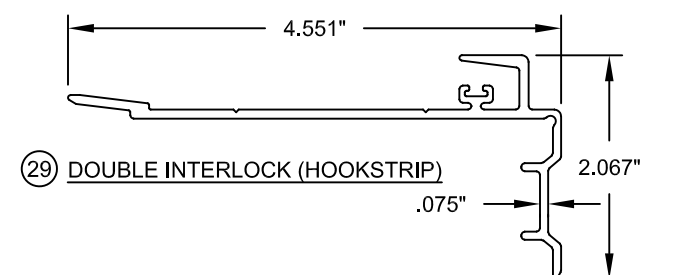

29 DOUBLE INTERLOCK (HOOKSTRIP)

BILL OF MATERIALS

ITEM #	DESCRIPTION	MATERIAL
1A	FRAME - 2T	PVC
1B	FRAME - 3T	PVC
3	GLAZING BEAD	PVC
4	FRAME CAP (JAMB COVER)	PVC
5	INTERLOCK	6063-T5
6	SILL CAP (THRESHOLD)	6063-T5
7	PANEL STILE/RAIL	PVC
9	HD REINFORCEMENT (INTERLOCK)	6065-T5
10	REINFORCEMENT (LOCK STILE, TOP/BTM RAIL)	6065-T5
11	FIXED PANEL SUPPORT	6065-T5
12	ROLLER TRACK	6063-T5
14	ROLLER SUPPORT	6063-T5
15	ANTI-LIFT OUT BLOCK	6063-T5
17	STANDARD SILL RISER	6063-T5
18	SILL RISER CAP	6063-T5
21	HOOKSTRIP	6063-T5
22	HOOKSTRIP FLANGE	6063-T5
23	MULLION (OFFSET BUTTSTILE)	PVC
24	REINFORCEMENT - MULLION (LARGE)	6063-T5
25	ROLLER ASSEMBLY	STEEL
26	REINFORCEMENT - MULLION (SMALL)	6063-T5
27	CORNER KEY	PVC
29	DOUBLE INTERLOCK (PANEL TO HOOKSTRIP)	6063-T5
30	LOCK AND HANDLE	-
31	STRIKE PLATE	-
39	SCREW COVER (HOOKSTRIP)	PVC
40	ASTRAGAL	6063-T5
41	WTSP, .187 x .290 Poly Fin	
42	WTSP, 0.8125" x 0.875" x 4" Fuzzy Pad (TOP/BTM RAIL)	
43	WTSP, 1.87" x 4" Fuzzy Pad	
44	WTSP, 1.25" x 4" Fuzzy Pad	
G	#8 X 1" PPH SMS	STEEL
H	#10 X 2-1/2" PPH SMS	STEEL
K	#8 X 1/2" PPH SMS	STEEL
L	#10 X 3" PPH SMS	STEEL
P	#8 X 1-1/2" PPH SMS	STEEL

PVC EXTRUSIONS ARE TO BE PRODUCED BY EXTRUDERS' LICENSEES UNDER "AAMA CERTIFICATION PROGRAMS FOR RIGID PVC EXTRUSIONS".

Title: **VINYL SLIDING GLASS DOOR (LM)** Drawn By: **JENS ROSOWSKI**

Description: **EXTRUSIONS & BOM** Date: **08/24/21**

Revision: Rev. By: Rev. Date:

Series/Model: **SGD3130V** Scale: **NTS** Sheet: **7 OF 7** Drawing No.: **SGD3130TDI-1** Rev:

CGI Impact Resistant Windows & Doors
WE'RE STRONGER™

3780 W 104TH STREET
HIALEAH, FL 33018
(305) 593-6590

PREPARED BY A. LYNN MILLER
1070 TECHNOLOGY DRIVE
N. VENICE, FL 34275
(941) 480-1600

COPYRIGHT © 2021
CGI WINDOWS AND DOORS, INC.
LIMITED LICENSE TO MAKE
COPIES FOR PERMITTING.

STATE OF TEXAS

★ ANTHONY LYNN MILLER ★

106954

PROFESSIONAL ENGINEER

A Lynn Miller 8/27/21

A. LYNN MILLER, P.E.
P.E.# 106594