

SLIDING GLASS DOOR - LARGE MISSILE IMPACT

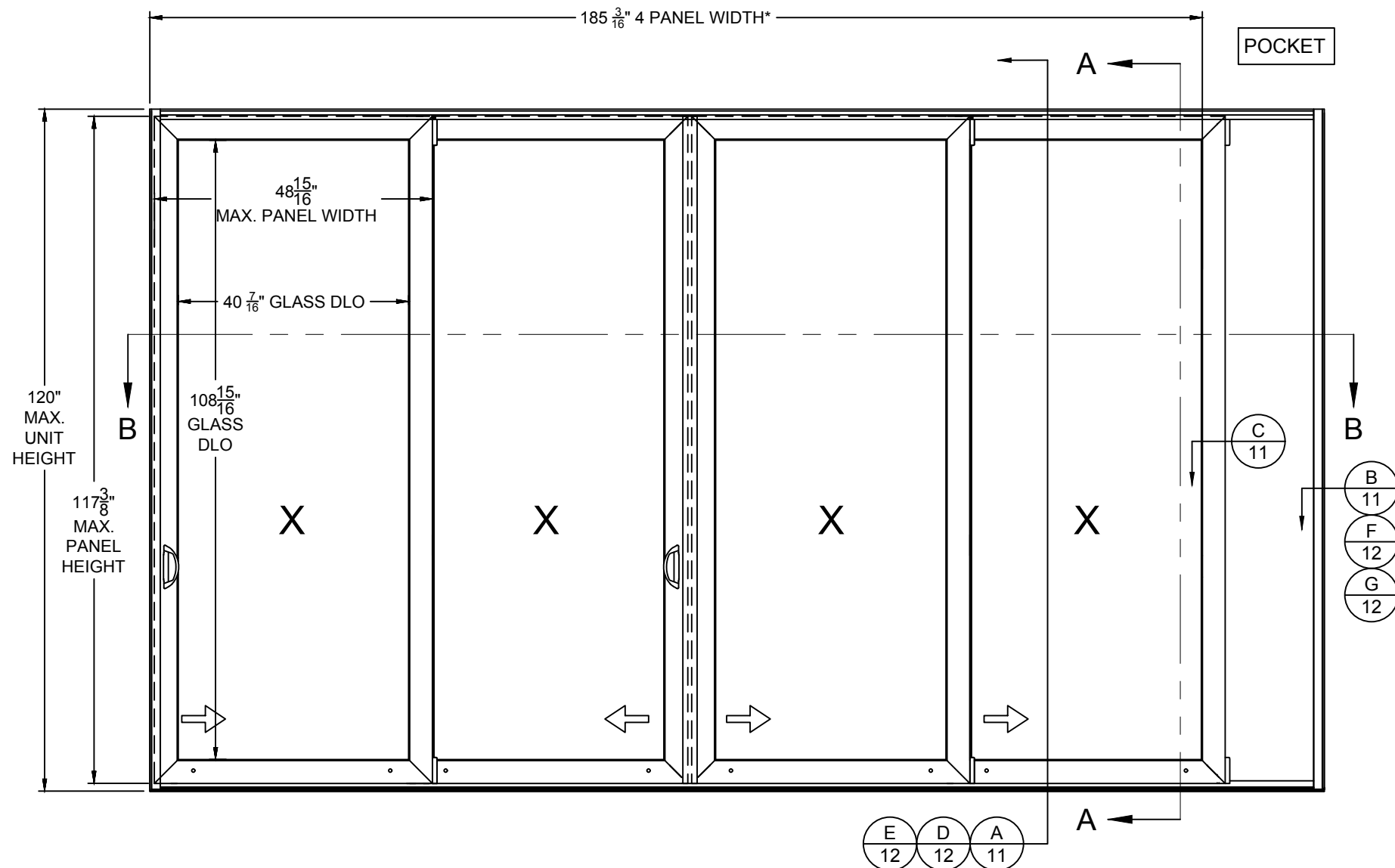

GENERAL NOTES:

1. THE PRODUCT SHOWN HEREIN IS DESIGNED AND MANUFACTURED TO COMPLY WITH THE REQUIREMENTS OF THE 2018 INTERNATIONAL BUILDING CODE AND INTERNATIONAL RESIDENTIAL CODE.
2. GLAZING OPTIONS: (SEE SHEET 3)
3. APPROVED CONFIGURATIONS INCLUDE BUT ARE NOT LIMITED TO:
"XO", "OX", "XX", "OXO", "XXX", "OXXO", "XXXX", "PX", "PXX", "PXXX", "PXXXX", "PXXP", "PXXXXP"
2 TRACK, 3 TRACK, 4 TRACK
4. ANCHORAGE: THE 33 1/3% STRESS INCREASE HAS NOT BEEN USED IN THE DESIGN OF THIS PRODUCT. SEE SHEETS 10-11 FOR ANCHOR DETAILS. WINDLOAD DURATION FACTOR Cd=1.6 WAS USED FOR WOOD ANCHOR CALCULATIONS.
5. PRODUCT APPROVED FOR IMPACT USE. SHUTTERS ARE NOT REQUIRED.
6. ALL FRAMES ARE PROCESSED AND SCREWED TOGETHER. VENTS ARE PROCESSED AND THERMAL WELDED TOGETHER.
7. SERIES / MODEL DESIGNATION SGD-8800.
8. THE DESIGNATION X AND O STAND FOR THE FOLLOWING:
X = OPERABLE SASH, O = FIXED SASH, P = POCKET/HOOKSTRIP
9. SECTION CALLOUTS APPLY TO ALL CONFIGURATIONS IN A SIMILAR LOCATION.
10. WEEP SLOTS = 1/2" x 1" LOCATED @ BOTH ENDS.

Custom WINDOW SYSTEMS
1900 SW 44TH AVE.
OCALA, FLORIDA 34474
WWW.CWS.CC

8800 PVC SLIDING GLASS DOOR - IMPACT

NO.	DESCRIPTION:	BY:	DATE:



5/28/2020

LUCAS A. TURNER, P.E.
TX PE #115094
TBPE REG. #F-18075
2428 OLD NATCHEZ TRC TRL
CAMDEN, TN 38320
PH. 941-380-1574

SHEET DESCRIPTION:

GENERAL NOTES AND ELEVATIONS

DRAWN BY: BLZ	DATE: 05/17/16
DWG #: TDI-1152	REV.: -
SCALE: 1:25	SHEET 1 OF 11

TABLE OF CONTENTS

GENERAL NOTES & ELEVATIONS.....	1
SECTION VIEWS.....	2
BOM & GLAZING DETAIL.....	3
EXTRUSIONS.....	4-5
TRACK WIDTHS.....	6
ANCHOR SCHEDULE & NOTES.....	7
ANCHOR PATTERNS.....	8-9
INSTALLATION DETAILS.....	10-11

MAX. PANEL SIZE	DESIGN PRESSURE RATING	IMPACT RATING
48-15/16" x 117-3/8"	+/-65 PSF	LARGE MISSILE

*(4) PANELS SHOWN; UNLIMITED NUMBER OF PANELS IS ALLOWABLE AS LONG AS INDIVIDUAL PANELS DO NOT EXCEED PANEL SIZE AS SHOW.

8800 PVC SLIDING GLASS DOOR - IMPACT

NO.	DESCRIPTION	BY:	DATE:



5/28/2020

LUCAS A. TURNER, P.E.
 TX PE #115094
 TBPE REG. #F-18075
 2428 OLD NATCHEZ TRC TRL
 CAMDEN, TN 38320
 PH. 941-380-1574

SHEET DESCRIPTION:

SECTION VIEWS

DRAWN BY: BLZ	DATE: 05/17/16
DWG #: TDI-1152	REV.: -
SCALE: 1:3	SHEET 2 OF 11

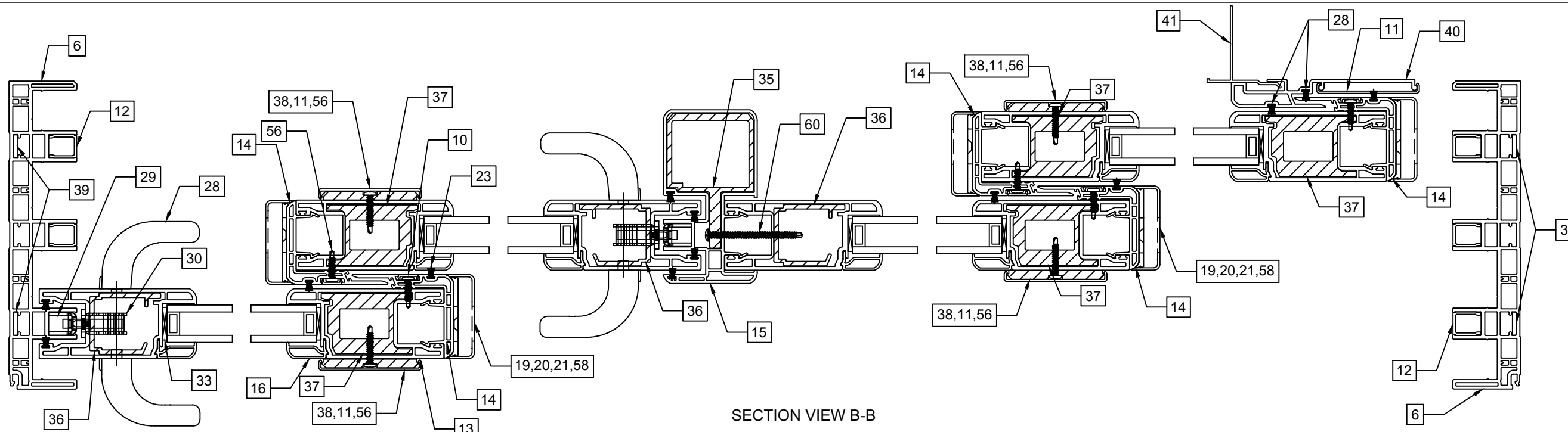

SECTION VIEW B-B

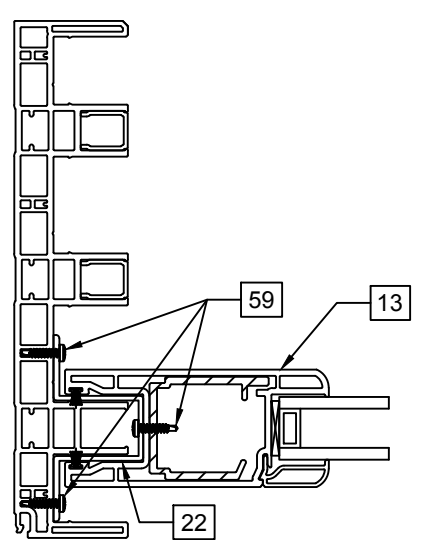
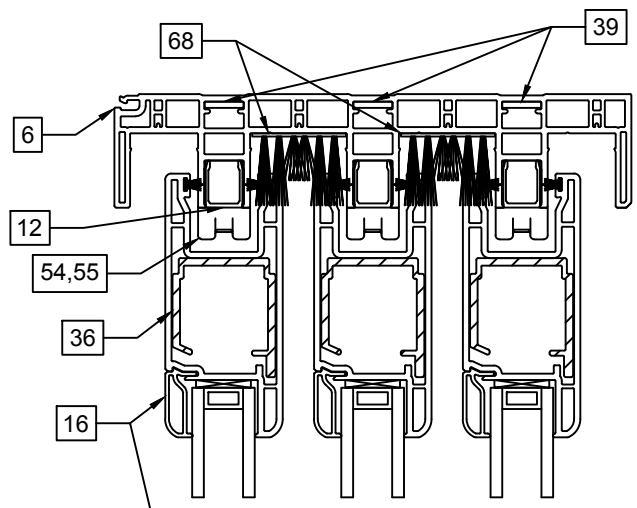

FIXED PANEL ATTACHMENT

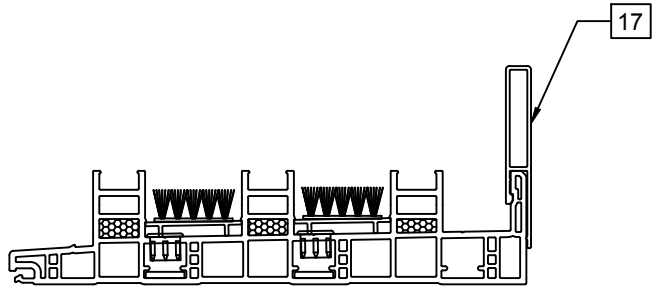
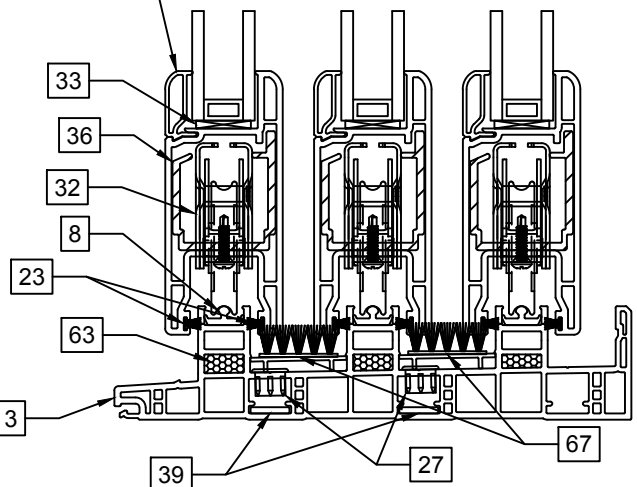

ALTERNATE SILL RISER VIEW LIMITED TO +65

NOTES:
 1) INSTALLATION W/NO SILL RISER ALLOWED TO THE FULL DP'S INDICATED ABOVE, IN LOCATIONS WHERE WATER INFILTRATION RESISTANCE IS NOT REQUIRED, SUCH AS BUT NOT LIMITED TO LOCATIONS WHERE AN OVER HANG IS PRESENT THAT IS AS WIDE AS THE WALL IS TALL.

ITEMS NOT SHOWN FOR CLARITY:
 20, 24-26, 31, 55-58, 61-62, 64-66

PARTS LIST				
ITEM	PART #	DESCRIPTION	VENDOR	MATERIAL
1	GLASS	SEE THIS SHEET		
2	H-6161	2-Track Sill	Vision	PVC
3	H-6163	3-Track Sill	Vision	PVC
4	H-6165	4-Track Sill	Vision	PVC
5	H-6160	2-Track Head/Jamb	Vision	PVC
6	H-6162	3-Track Head/Jamb	Vision	PVC
7	H-6164	4-Track Head/Jamb	Vision	PVC
8	S-2064	Roller Track Insert	Keymark	Aluminum
9	S-6171	Cover, Sill Track	Vision	PVC
10	S-6169	Cover, Interlock	Vision	PVC
11	S-6172	Cover, External Reinforcement/P-Hook	Vision	PVC
12	S-6175	Track Filler, Frame	Vision	PVC
13	H-6166	Panel Stile/Rail	Vision	PVC
14	H-6168	Interlock, Snap-On	Vision	PVC
15	H-6167	Astragal	Vision	PVC
16	H-6170	Glazing Bead, I.G., 1"	Vision	PVC
17	H-2060	Sill Riser, 2.875"	Keymark	Aluminum
18	H-2062	Sill Riser, 4.062"	Keymark	Aluminum
19	P-5517	Panel Guide, Interlock	Bear's Metal	Aluminum
20	P-5558	Support Channel, Bot Rail, Interlock	Bear's Metal	Aluminum
21	P-5511	Cover, Panel Guide, Interlock	Lawrence	Nylon
22	P-5516	Bracket, Fixed Panel	Bear's Metal	Aluminum
23	P-3300	Wtsp., 0.280" x 0.187" Back, Fin, Black	Ultrafab	
24	P-3438	Backbedding, Purfect Glaze "H" Hot Melt	Henkel/Sika	Silicone
25	P-3514	Screw, #10 x 2" Ph Comb Hd	Fastenal	Steel
26	P-3587	Screw, #8 x 1" PH FL TEK - Roller Asm/Mortise Lock	Fastenal	Steel
27	P-3752	Hole Plug, 0.500" Dia.	Progress Plastics	Nylon
28	P-3789	Handle Set with Thumb Turn	Amesbury or Roto	
29	P-3792	Keeper	Amesbury	
30	P-3793	Multi-Point Mortise Lock	Amesbury	
31	P-4250	Screw, #10 x 2.5" PH PN SMS - Keeper	Fastenal	Steel
32	P-5287	Tandem Roller Assy, 2.125" Dia Wheel	Amesbury	
33	P-5438	Setting Blocks, 0.090" x 0.875" x 1.5"	Franke Lowe	Rubber
35	H-2068	Reinforcement, Astragal	Keymark	Aluminum
36	S-1775	Reinforcement, Lock Stile/Rails	Keymark	Aluminum
37	H-2111	Reinforcement, HD, Interlock	Keymark	Aluminum
38	S-2071	Reinforcement, External, Interlock	Keymark	Aluminum
39	S-2069	Frame Insert, Installation Anchors	Keymark	Aluminum
40	H-2063	P-Hook	Keymark	Aluminum
41	S-2065	P-Hook Adaptor	Keymark	Aluminum
42	S-2048	Screen, Astragal	Keymark	Aluminum
43	S-2050	Screen, 1-Track Head	Keymark	Aluminum
44	H-2051	Screen, 1-Track Jamb	Keymark	Aluminum
45	S-2052	Screen, 1-Track Sill	Keymark	Aluminum
46	S-2053	Screen, 2-Track Head	Keymark	Aluminum
47	S-2054	Screen, 2-Track Jamb	Keymark	Aluminum
48	S-2055	Screen, 2-Track Sill	Keymark	Aluminum
49	S-2056	Screen, 3-Track Head	Keymark	Aluminum
50	S-2057	Screen, 3-Track Jamb	Keymark	Aluminum

PARTS LIST				
ITEM	PART #	DESCRIPTION	VENDOR	MATERIAL
51	S-2058	Screen, 3-Track Sill	Keymark	Aluminum
52	S-2059	Screen, Snap Cover	Keymark	Aluminum
53	S-2070	Screen, Interlock	Profile	Aluminum
54	P-5477	Block, Anti-Lift	Lawrence	Nylon
55	P-5559	Screw, #14 x 4" PH PN SMS	Fastenal	Steel
56	P-4269	Screw, #8 x 1" PH PN Tek	Fastenal	Steel
57	P-3556	Screw, #8 x 2.5" PH FL Tek	Fastenal	Steel
58	P-4962	Screw, #8 x 3" PH FL Tek	Fastenal	Steel
59	P-5565	Screw, #12 x 1 1/2" PH PN SMS	Fastenal	Steel
60	P-5566	Screw, #12 x 2 1/2" PH PN SMS	Fastenal	Steel
61	P-3609	Bumper, Panel Stop	Parker Seals	Rubber
62	P-4291	Panel Stop Housing	M & M	Nylon
63	P-5479	Foam Block, Open Cell, 0.844" x 0.531" x 1"	Lamatek	
64	P-5492	Gasket, Frame Assembly, 2-Track	Lamatek	Butyl
65	P-5493	Gasket, Frame Assembly, 3-Track	Lamatek	Butyl
66	P-5494	Gasket, Frame Assembly, 4-Track	Lamatek	Butyl
67	P-4659	Dust Plug, 1-1/4" x 3" x 0.5"	Ultrafab	
68	P-4366	Dust Plug, 1" x 3" x 1"	Ultrafab	
69		Screen, Spline	Team Plastics	Rubber
70		Screen, Cloth		

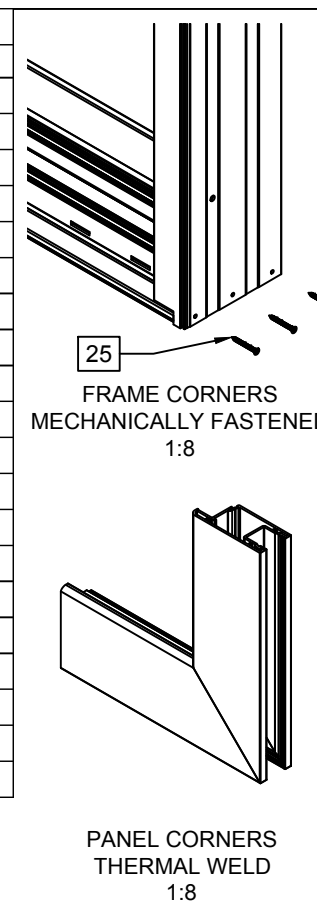

Custom WINDOW SYSTEMS
 1900 SW 44TH AVE.
 OCALA, FLORIDA 34474
 WWW.CWS.CC

8800 PVC SLIDING GLASS DOOR - IMPACT

NO.	DESCRIPTION	BY:	DATE:

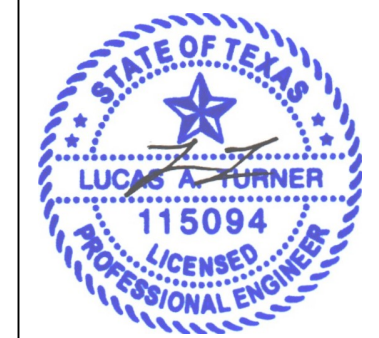

5/28/2020

LUCAS A. TURNER, P.E.
 TX PE #115094
 TBPE REG. #F-18075
 2428 OLD NATCHEZ TRC TRL
 CAMDEN, TN 38320
 PH. 941-380-1574

SHEET DESCRIPTION:
BOM AND GLAZING DETAIL

DRAWN BY:	DATE:
BLZ	05/17/2016
DWG #:	REV.:
TDI-1152	-
SCALE:	SHEET
1:2	3 OF 11

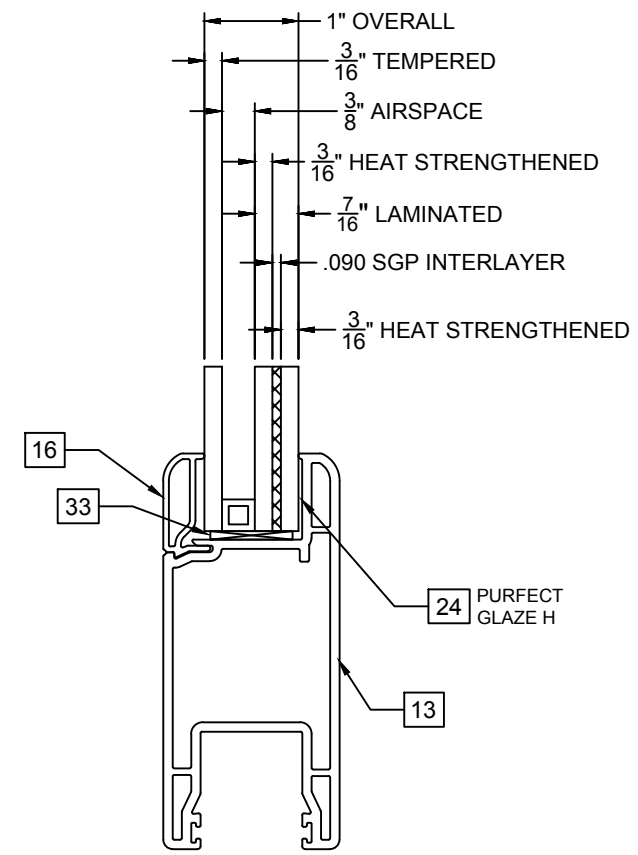

**8800 PVC
SLIDING GLASS
DOOR - IMPACT**

NO.	DESCRIPTION	BY:	DATE:



5/28/2020

LUCAS A. TURNER, P.E.
TX PE #115094
TBPE REG. #F-18075
2428 OLD NATCHEZ TRC TRL
CAMDEN, TN 38320
PH. 941-380-1574

SHEET DESCRIPTION:

EXTRUSIONS

DRAWN BY:	DATE:
BLZ	05/17/16
DWG #:	REV.:
TDI-1152	-
SCALE:	SHEET
1:2	4 OF 11

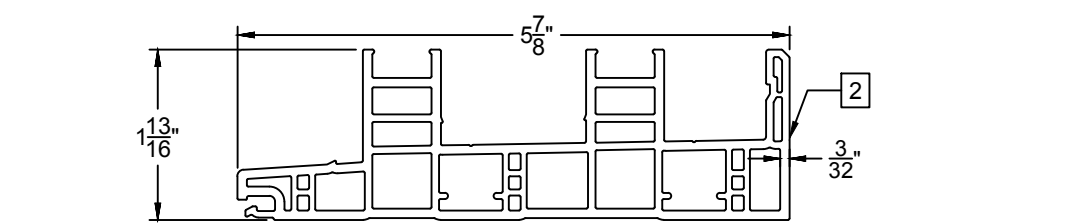

2-Track Sill - 6161

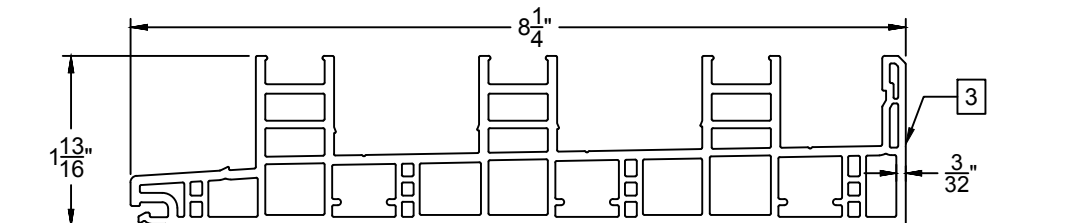

3-Track Sill - 6163

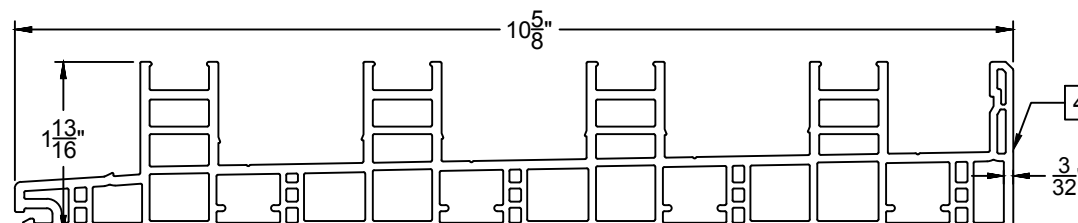

4-Track Sill - 6165

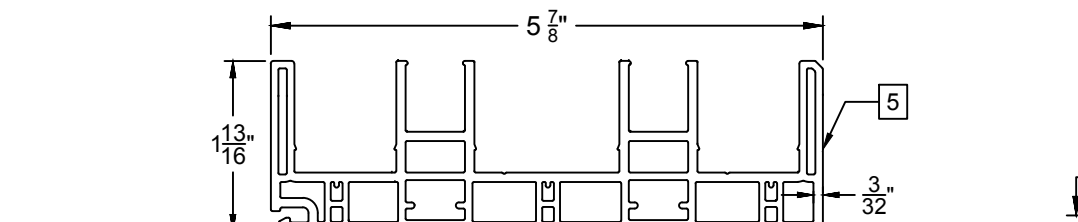

2-Track Head/Jamb - 6160

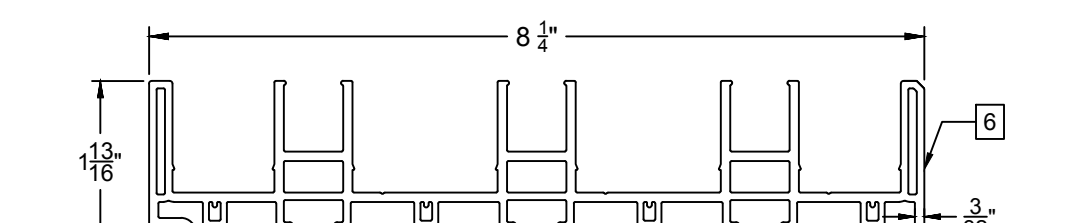

3-Track Head/Jamb - 6162

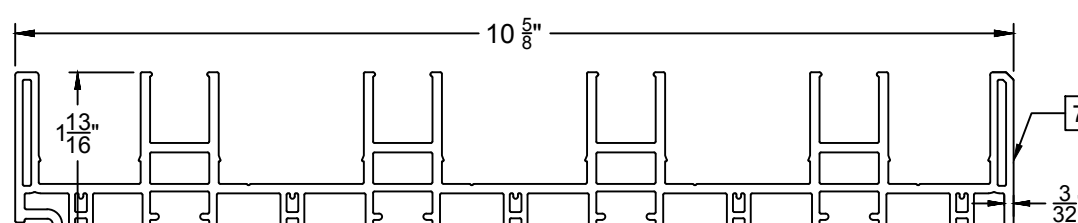

4-Track Head/Jamb - 6164

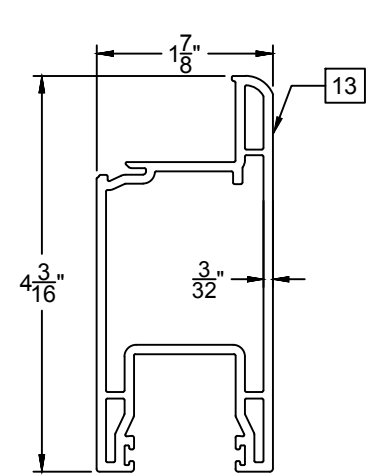

Panel Head/Sill/Stile - 6166

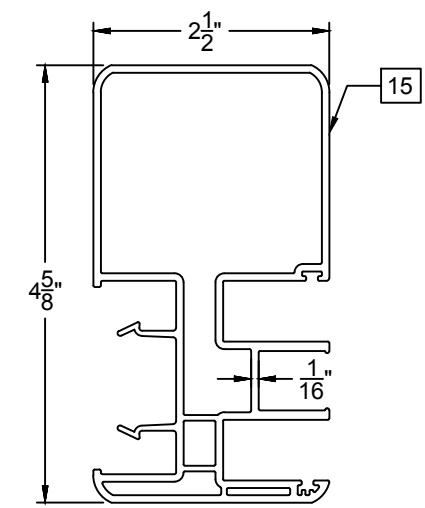

Astragal - 6167

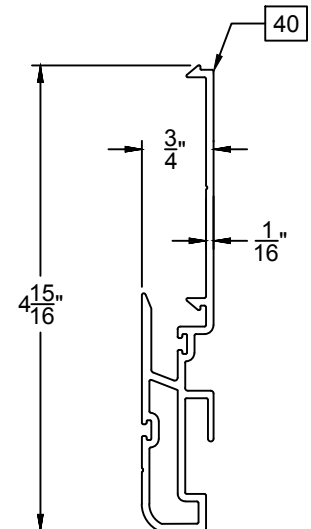

P-Hook - 2063
6063-T6

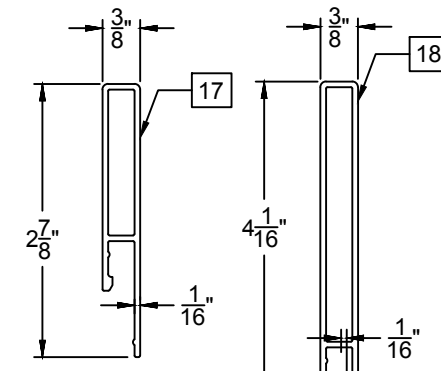

Sill Riser - 2060
6063-T6

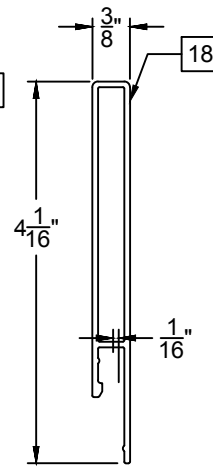

Sill Riser - 2062
6063-T6

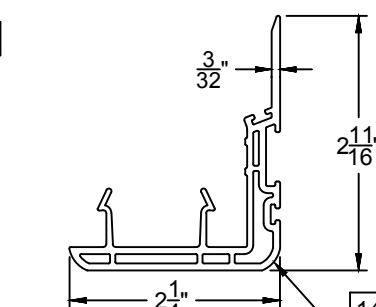

Lock Stile - 2086

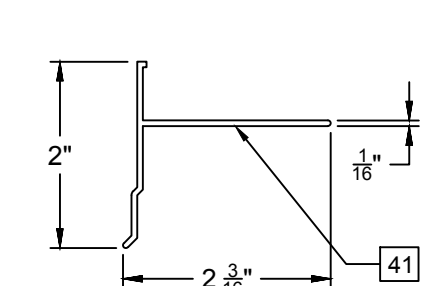

P-Hook Adaptor - 2065
6063-T6

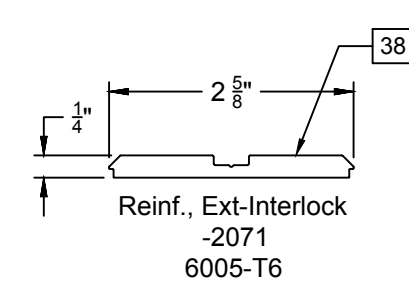

Reinf., Ext-Interlock
-2071
6005-T6

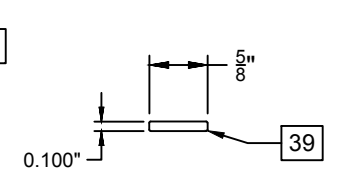

Reinf., Frame - 2069
6063-T6

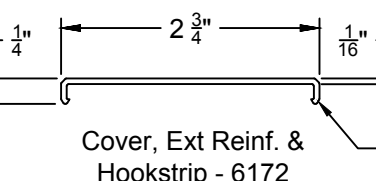

Cover, Ext Reinf. &
Hookstrip - 6172

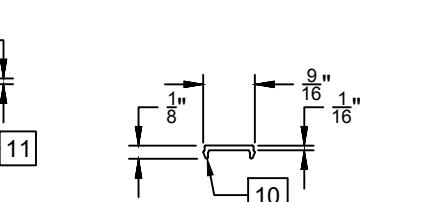

Cover, Interlock - 6169

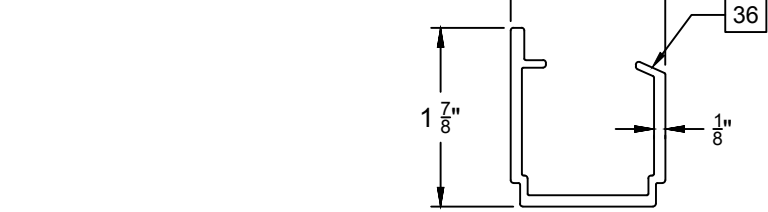

Reinf., Lock Stile - 1775
6005-T6

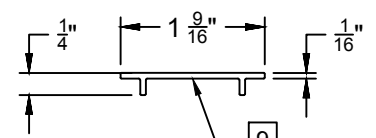

Cover, Sill Track - 6171

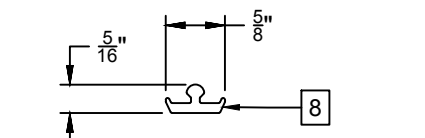

Roller Track Insert -2064
6063-T5

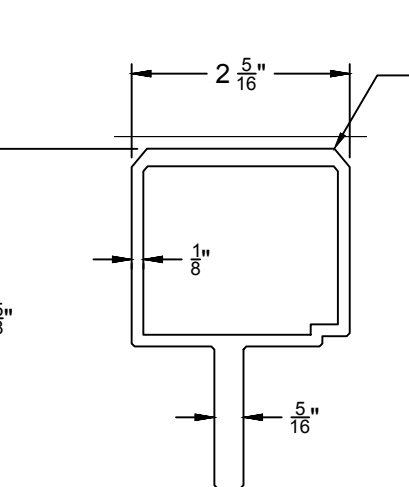

Reinf., Astragal - 2068
6005-T6

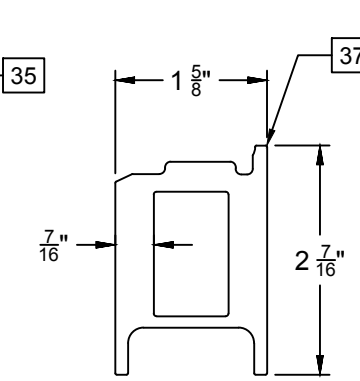

Reinf., HD Interlock - 2111
6005-T6

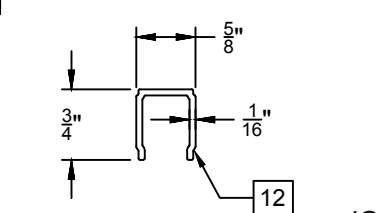

Track Filler - 6175

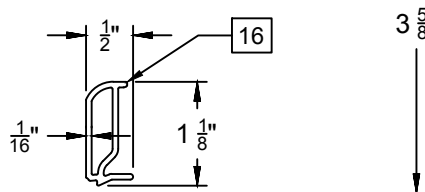

IG Glazing Bead - 6170

NOTE: ALL EXTRUSIONS ARE RIGID PVC UNLESS OTHERWISE NOTED.

8800 PVC SLIDING GLASS DOOR - IMPACT

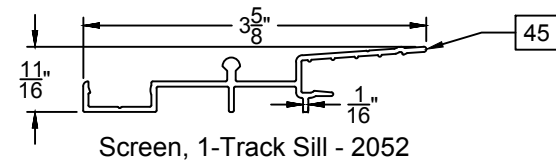

Screen, 1-Track Sill - 2052

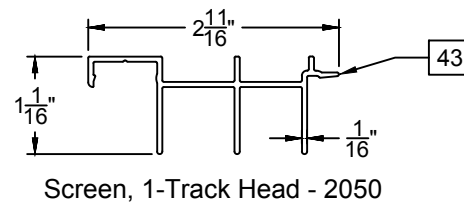

Screen, 1-Track Head - 2050

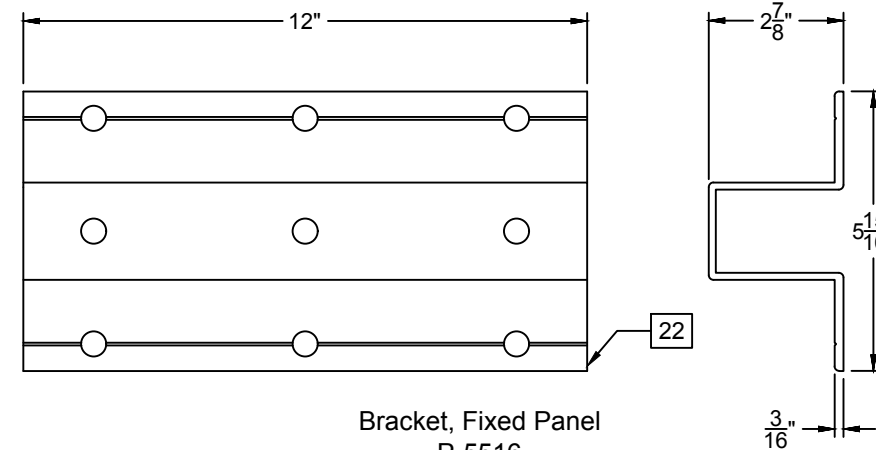

Bracket, Fixed Panel
P-5516

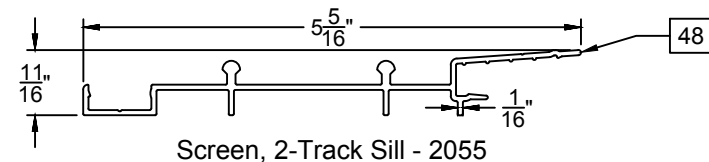

Screen, 2-Track Sill - 2055

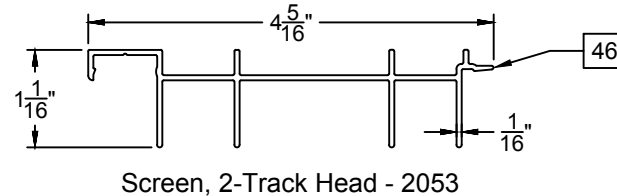

Screen, 2-Track Head - 2053

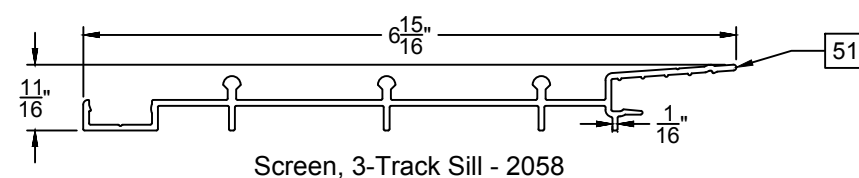

Screen, 3-Track Sill - 2058

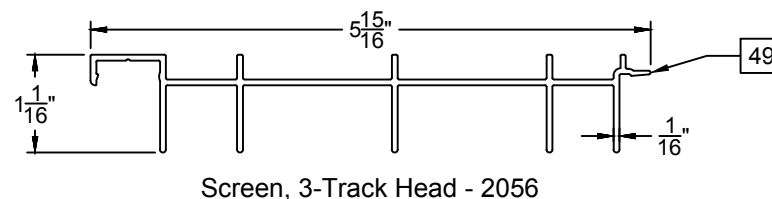

Screen, 3-Track Head - 2056

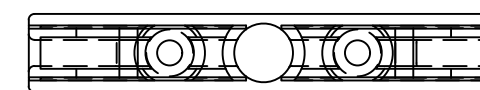

Block, Anti-Lift
P-5477, Nylon

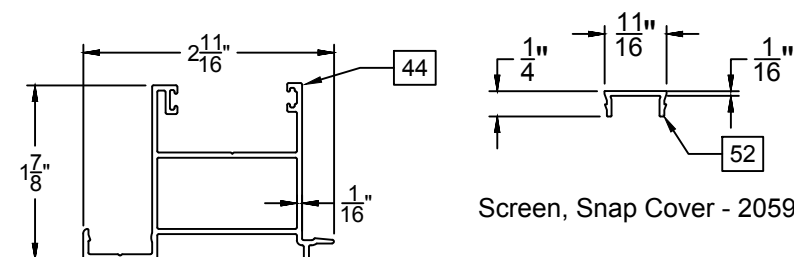

Screen, 1-Track Jamb - 2051

Screen, Snap Cover - 2059

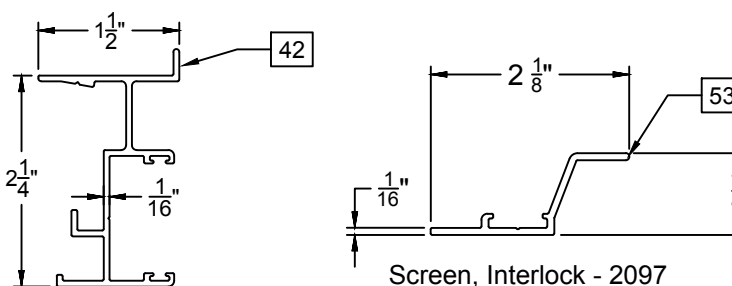

Screen, Astragal - 2048

Screen, Interlock - 2097

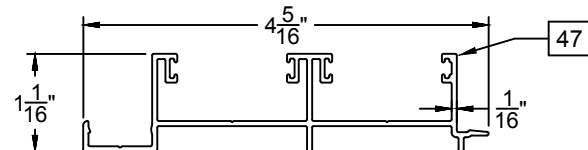
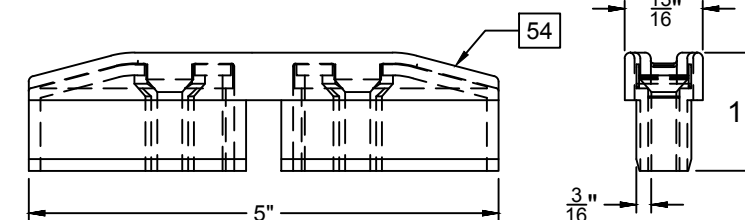

Screen, 2-Track Jamb - 2054

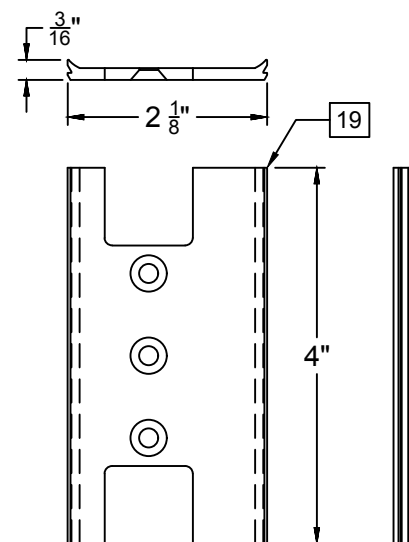

Panel Guide, Interlock - P-5517

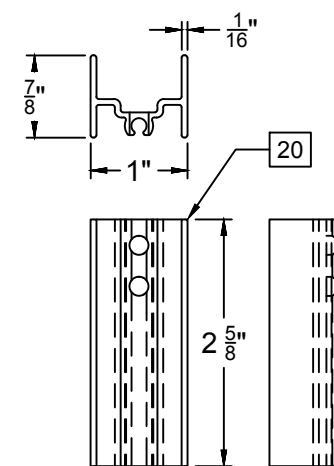

Support Channel, Bot
Rail - Interlock - P-5558

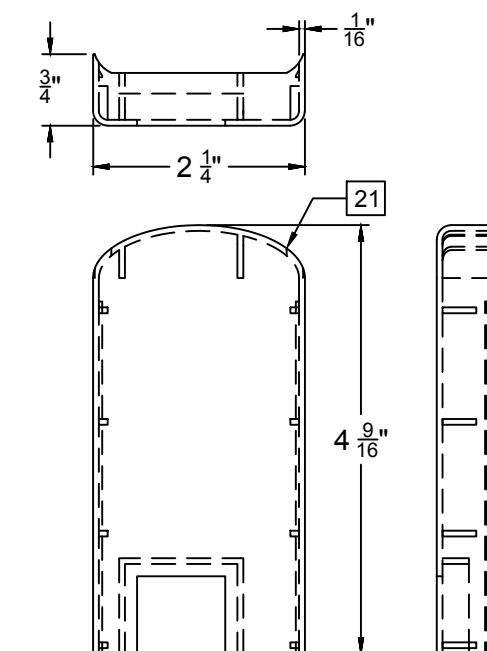

Cover, Interlock - Reinf.
P-5511, Nylon

NOTE: ALL EXTRUSIONS ARE ALUMINUM 6063-T6 UNLESS OTHERWISE NOTED.

NO.	DESCRIPTION	BY:	DATE:



5/28/2020

LUCAS A. TURNER, P.E.
 TX PE #115094
 TBPE REG. #F-18075
 2428 OLD NATCHEZ TRC TRL
 CAMDEN, TN 38320
 PH. 941-380-1574

SHEET DESCRIPTION:

EXTRUSIONS

DRAWN BY:	DATE:
BLZ	05/17/2016
DWG #:	REV.:
TDI-1152	-
SCALE:	SHEET
1:2	5 OF 11

**8800 PVC
SLIDING GLASS
DOOR - IMPACT**

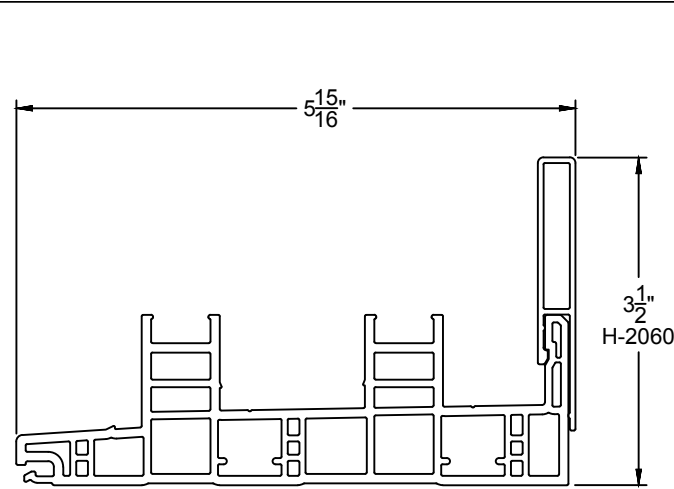

2T Sill w/Riser

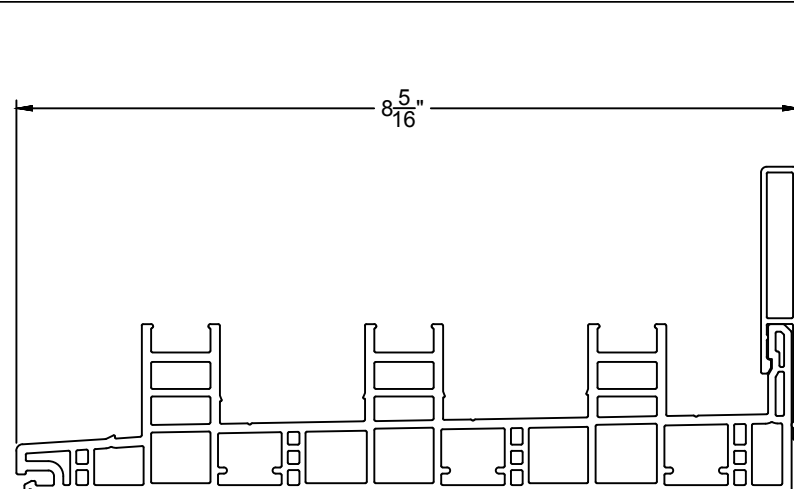

3T Sill w/Riser

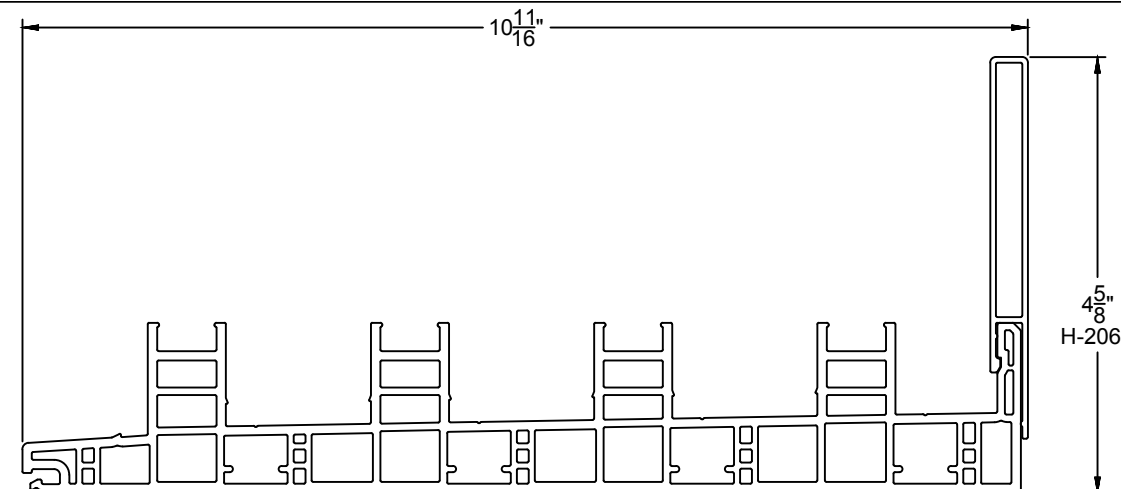

4T Sill w/Riser

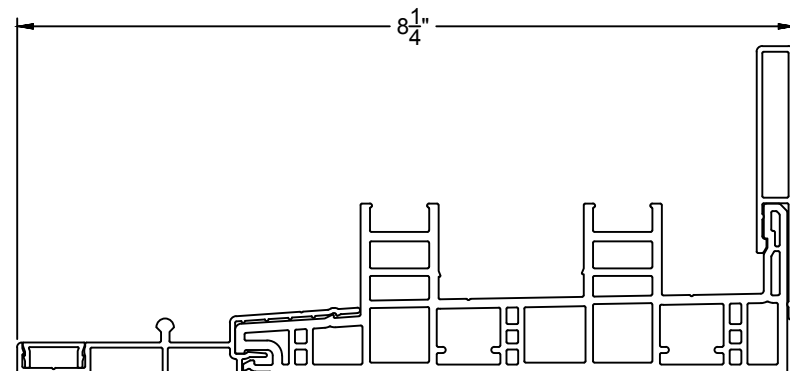

2T Sill w/ 1T Screen

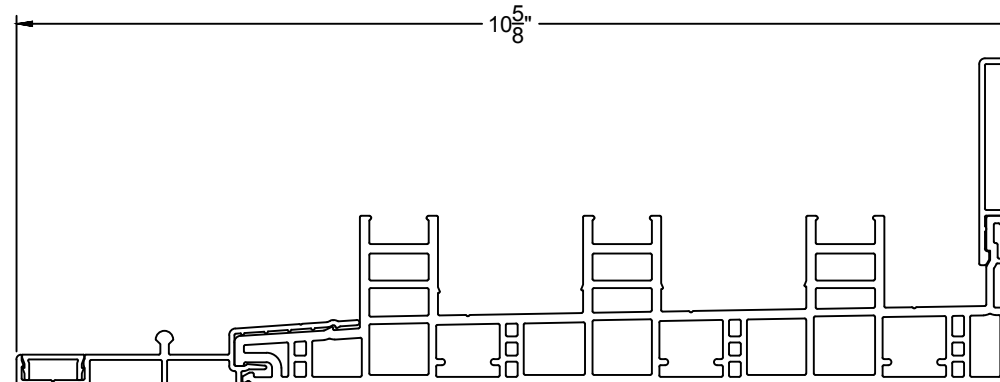

3T Sill w/ 1T Screen

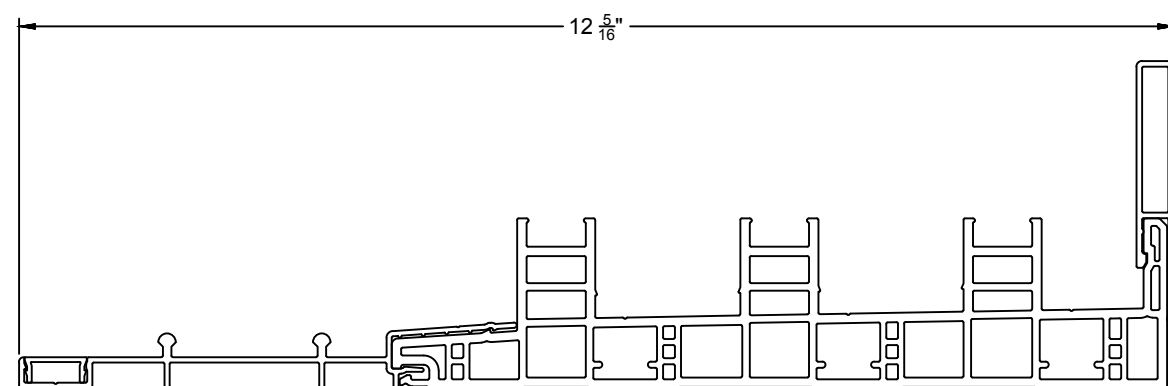

3T Sill w/ 2T Screen

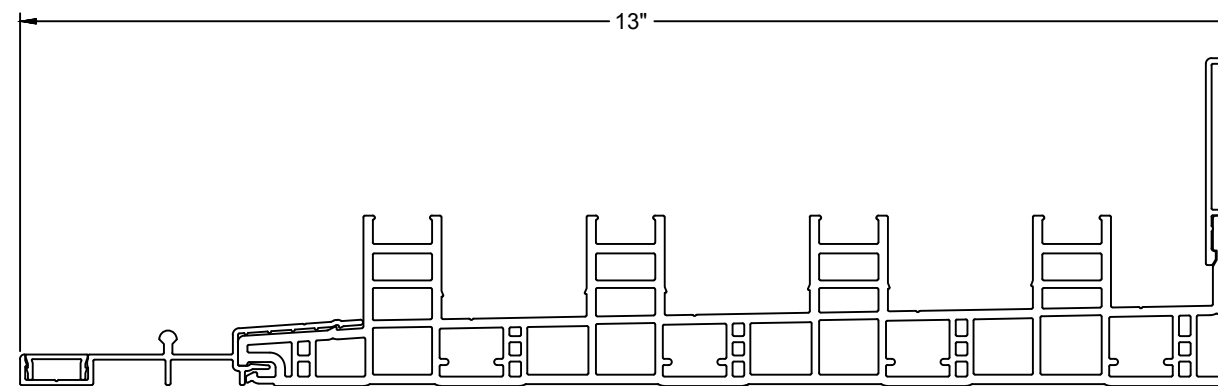

4T Sill w/ 1T Screen

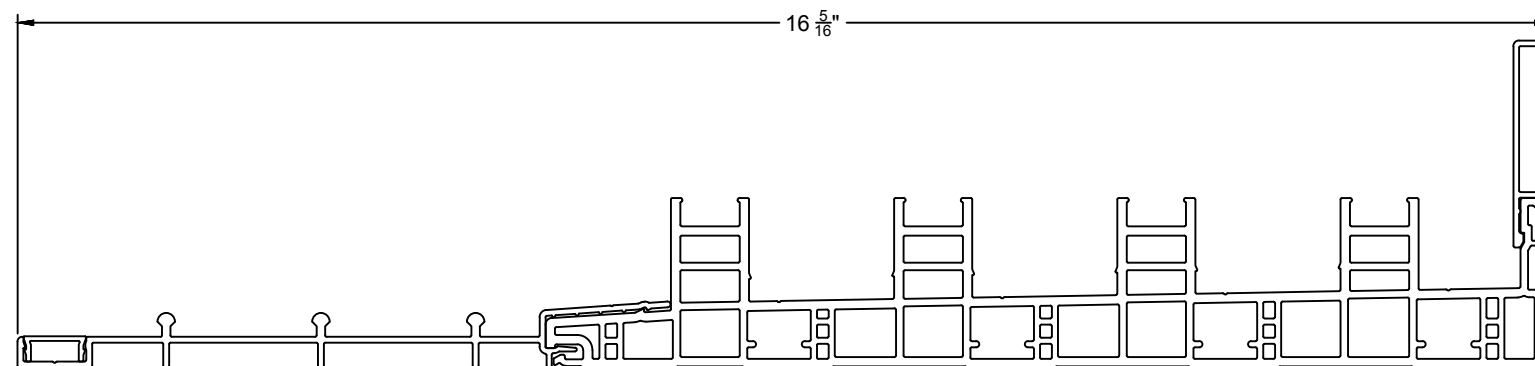

4T Sill w/ 3T Screen

NO.	DESCRIPTION:	BY:	DATE:

REVISIONS



5/28/2020

LUCAS A. TURNER, P.E.
TX PE #115094
TBPE REG. #F-18075
2428 OLD NATCHEZ TRC TRL
CAMDEN, TN 38320
PH. 941-380-1574

SHEET DESCRIPTION:

TRACK WIDTHS

DRAWN BY: BLZ	DATE: 05/17/16
DWG #: TDI-1152	REV.: -
SCALE: 1:2	SHEET 6 OF 11

**8800 PVC
SLIDING GLASS
DOOR - IMPACT**

NO.:	DESCRIPTION:	BY:	DATE:



5/28/2020

LUCAS A. TURNER, P.E.
TX PE #115094
TBPE REG. #F-18075
2428 OLD NATCHEZ TRC TRL
CAMDEN, TN 38320
PH. 941-380-1574

SHEET DESCRIPTION:
**ANCHOR SCHEDULE AND
NOTES**

DRAWN BY: BLZ	DATE: 05/17/16
DWG #: TDI-1152	REV.: -
SCALE: 1:25	SHEET 7 OF 11

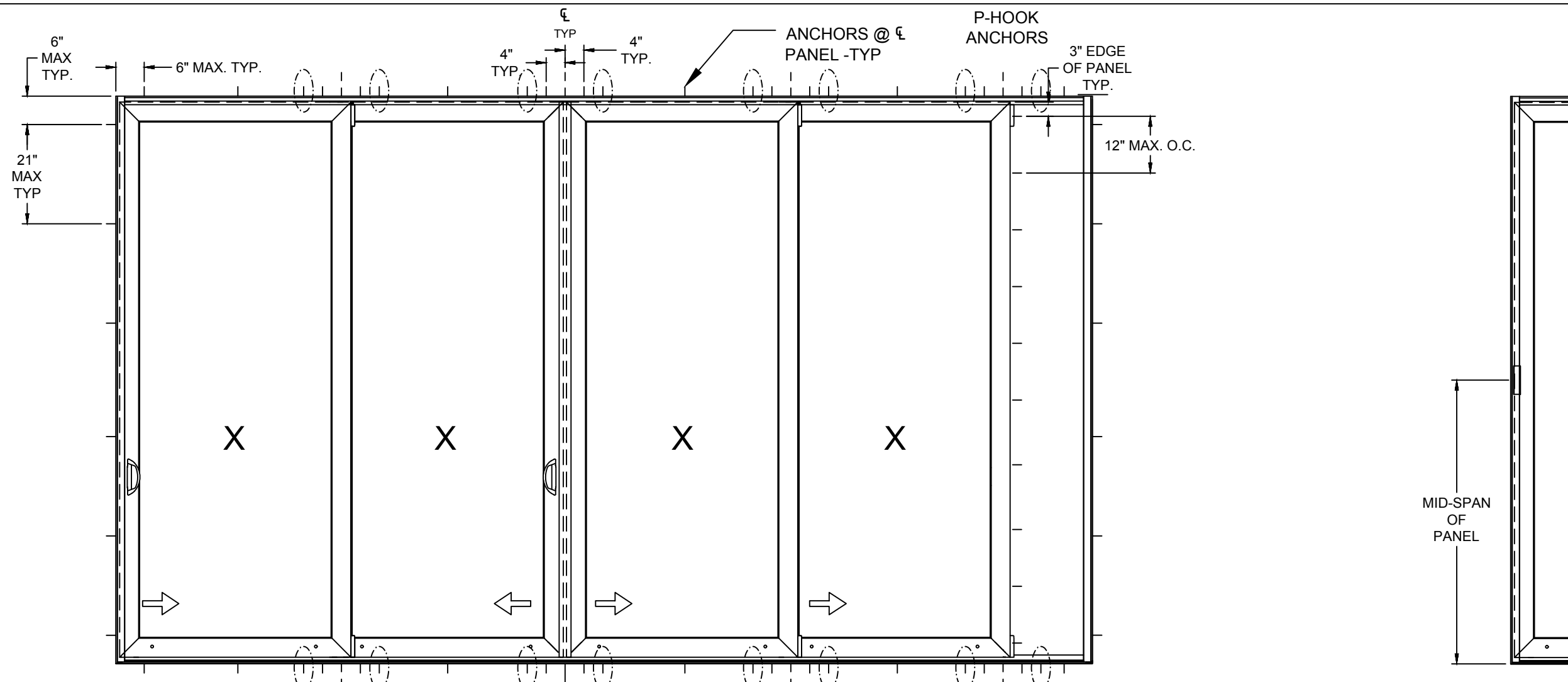

* CIRCLED ANCHOR LOCATIONS REQ'D ONLY IN WOOD INSTALLATIONS. (SEE NEXT SHEET FOR DETAIL)

NOTES:

1. INSTALL TWO ANCHORS AT EACH INSTALLATION LOCATION (SEE LAYOUT DETAILS ON SHEETS 8 & 9), EXCEPT FOR 2T SILL & WOOD INSTALLATION LOCATIONS. SEE SPECIAL LOCATIONS AND SPACING FOR 2T SILL (SHEET 8). INSTALL ONE ANCHOR AT EACH WOOD INSTALLATION LOCATION (CIRCLED). SILL ANCHOR SPACING SAME AS HEAD FOR 3T AND 4T. INSTALL ONE ANCHOR AT EACH LOCATION IN HOOKSTRIP.
2. SHIM AS REQ AT EACH INSTALLATION ANCHOR USING LOAD BEARING SHIMS. MAX. ALLOWABLE SHIM STACK TO BE 1/4". USE SHIMS WHERE SPACE GREATER THAN 1/16" IS PRESENT. LOAD BEARING SHIMS SHALL BE CONSTRUCTED OF HIGH DENSITY PLASTIC OR BETTER. WOOD SHIMS ARE NOT ALLOWED.
3. ANCHOR TYPE, SIZE, SPACING AND EMBEDMENT SHALL BE AS SPECIFIED IN THESE DRAWINGS, SEE TABLE 1, SHEET 10.
4. ALL INSTALLATION ANCHORS MUST BE MADE OF OR PROTECTED WITH A CORROSION RESISTANT MATERIAL OR COATING. DISSIMILAR METALS OR MATERIALS IN CONTACT WITH PRESSURE TREATED WOOD MUST BE PROTECTED TO PREVENT REACTION.
5. INSTALLATION ANCHORS SHALL BE IN ACCORDANCE WITH ANCHOR MANUFACTURER'S INSTALLATION INSTRUCTIONS, AND ANCHORS SHALL NOT BE USED IN SUBSTRATES WITH STRENGTHS LESS THAN THE MINIMUM SPECIFIED IN TABLE 1, SHEET 10.
6. ANCHOR EMBEDMENT TO SUBSTRATE SHALL BE BEYOND WALL DRESSING OR STUCCO. FOR CONCRETE/CMU OPENINGS, EMBEDMENT SHALL BE BEYOND WOOD BUCKS, IF USED, INTO SUBSTRATE. INSTALLATIONS TO SOLID CONCRETE OR GROUT-FILLED CMU MAY INCLUDE BUT DO NOT REQUIRE 1X WOOD BUCKS BETWEEN THE PRODUCT AND SUBSTRATE. INSTALLATIONS TO HOLLOW CMU REQUIRE THE USE OF 1X BUCKS BETWEEN THE PRODUCT AND SUBSTRATE.
7. A MINIMUM CENTER-TO-CENTER SPACING SHALL BE MAINTAINED BETWEEN ALL FASTENERS: 3" FOR SOLID CONCRETE, 6" FOR CMU MASONRY, 1" FOR WOOD AND METAL.
8. WOOD OR MASONRY OPENINGS, BUCKS AND BUCK FASTENERS SHALL BE PROPERLY DESIGNED BY THE ARCHITECT OR ENGINEER OF RECORD AND INSTALLED TO TRANSFER WIND LOADS TO THE STRUCTURE. SUBSTRATES SHALL MEET THE MINIMUM STRENGTH REQUIREMENTS AS SHOWN IN TABLE 1, SHEET 10. CONCRETE AND MASONRY SUBSTRATES MAY NOT BE CRACKED.
9. SEALING AND FLASHING STRATEGIES FOR OVERALL WATER RESISTANCE OF INSTALLATION SHALL BE DONE BY OTHERS FOLLOWING THE CURRENT VERSION OF THE REFERENCE DOCUMENTS:
FMA/AAMA 100(FIN WINDOWS), FMA/AAMA 200(FLANGE WINDOWS), FMA/WDMA 250(BOX WINDOWS), FMA/AAMA/WDMA 300(EXTERIOR DOORS)

8800 PVC SLIDING GLASS DOOR - IMPACT

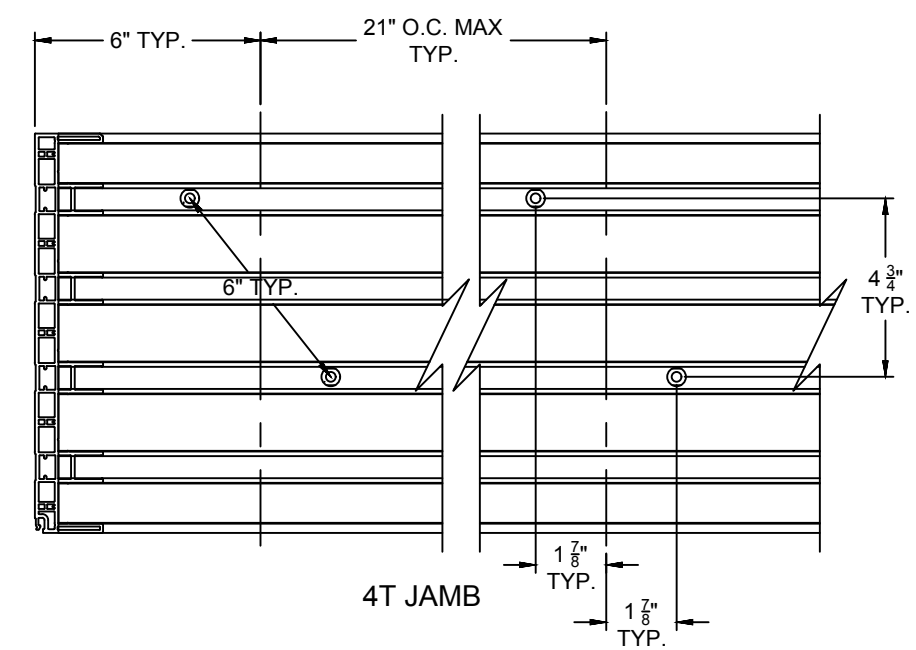
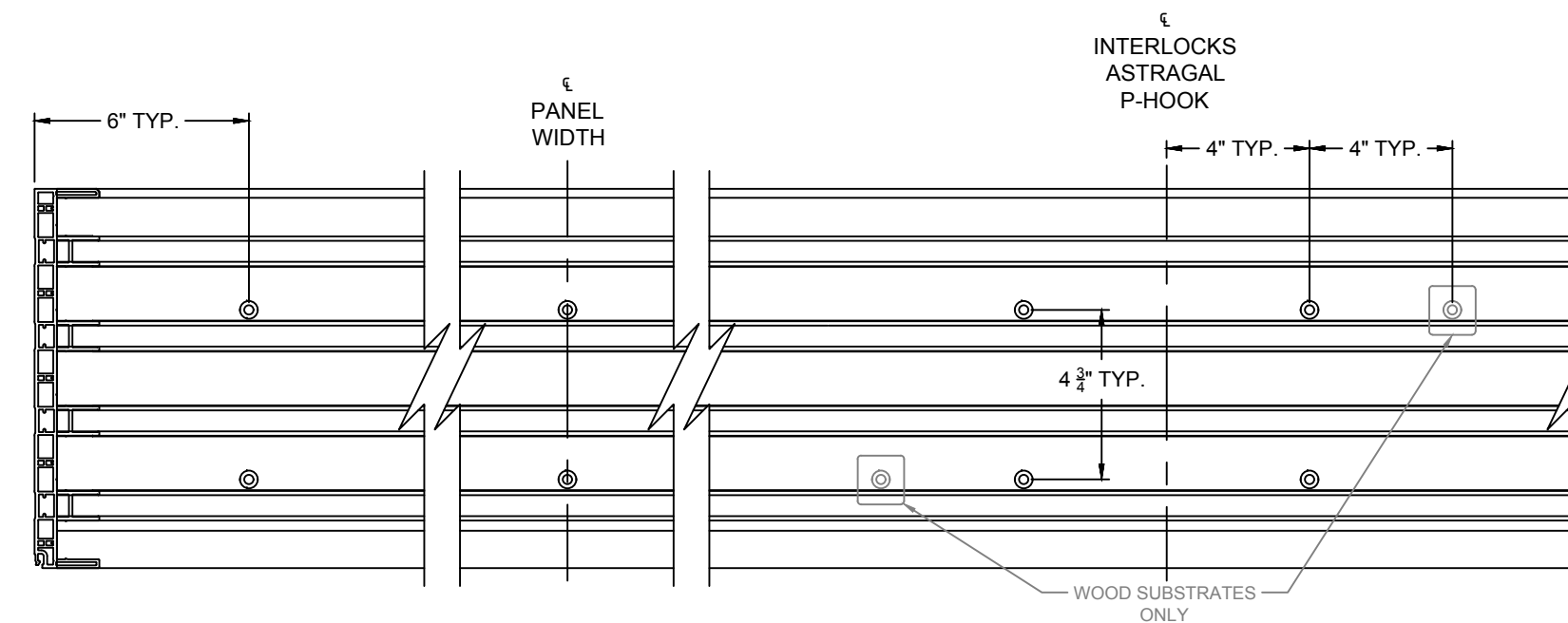
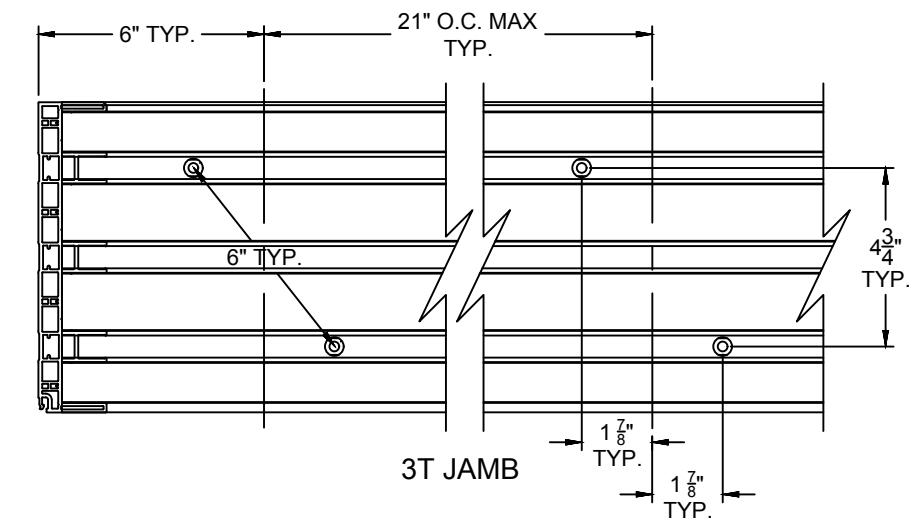
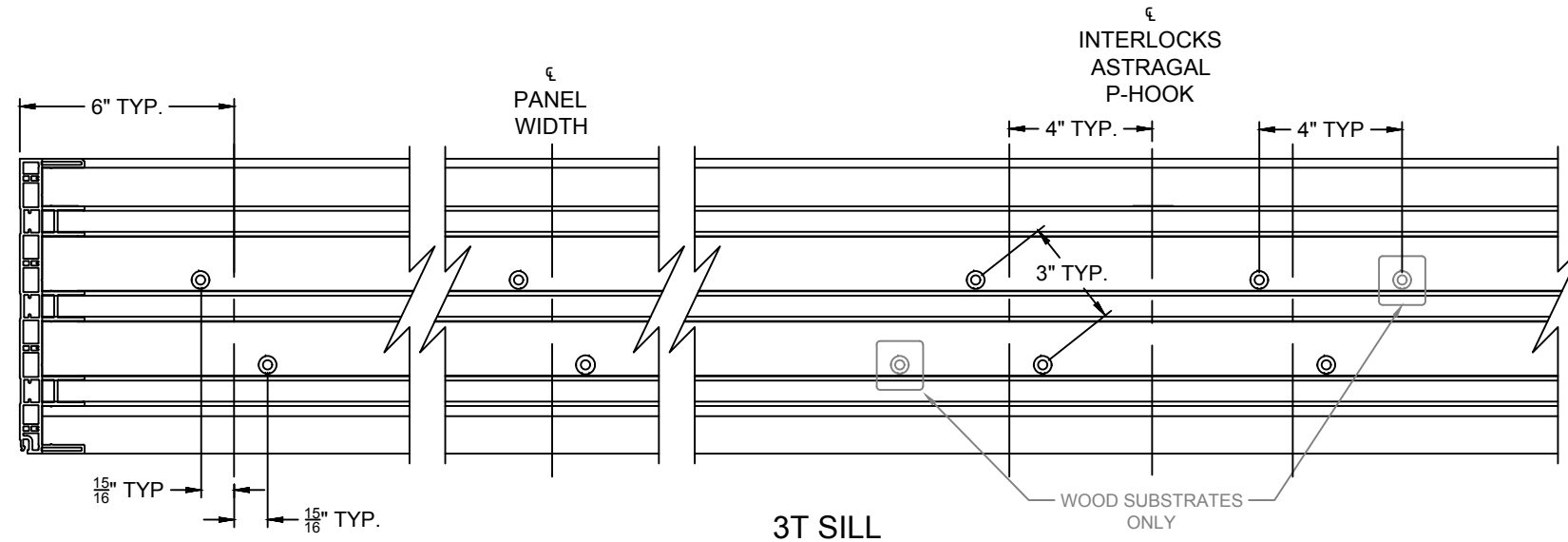
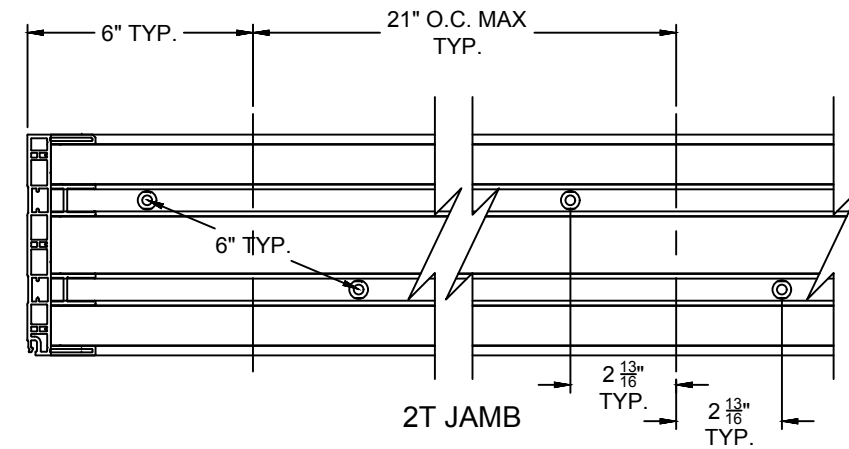
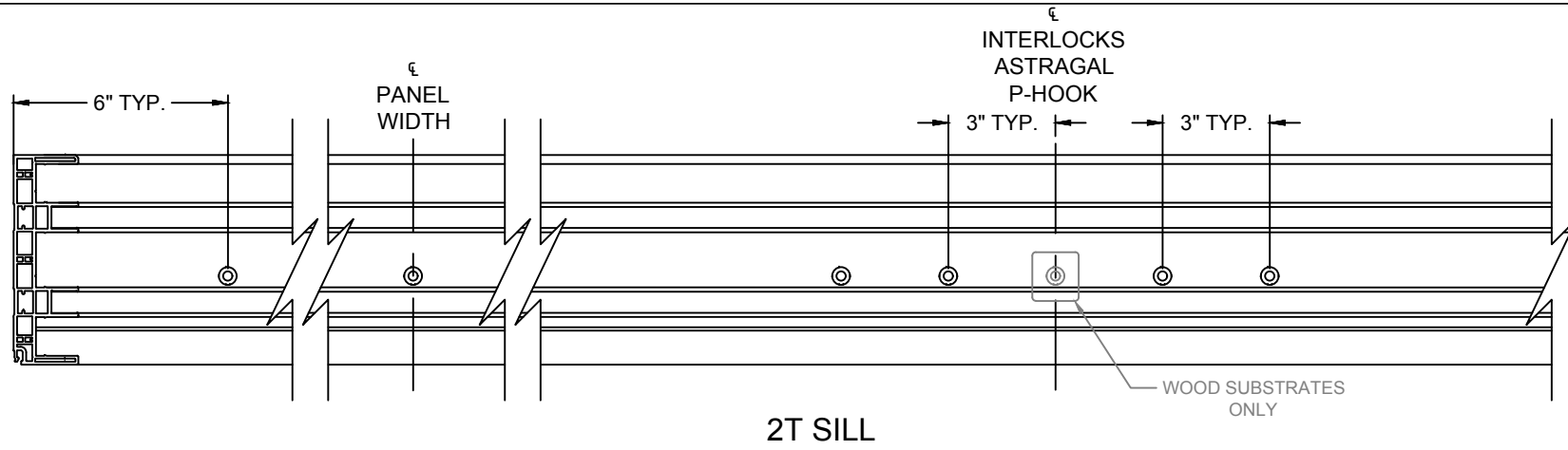

NO.	DESCRIPTION:	BY:	DATE:

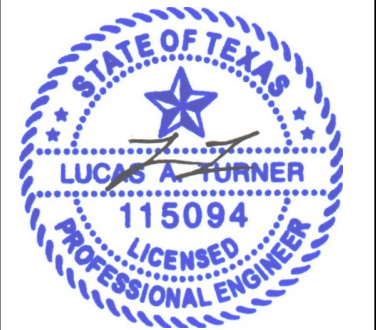

5/28/2020

LUCAS A. TURNER, P.E.
 TX PE #115094
 TBPE REG. #F-18075
 2428 OLD NATCHEZ TRC TRL
 CAMDEN, TN 38320
 PH. 941-380-1574

SHEET DESCRIPTION:
ANCHOR PATTERNS (JAMB & SILL)

DRAWN BY: BLZ	DATE: 05/17/16
DWG #: TDI-1152	REV.: -
SCALE: 1:5	SHEET 8 OF 11

* CIRCLED ANCHOR LOCATIONS REQ'D ONLY IN WOOD INSTALLATIONS.

NOTE: CL = CENTERLINE OF INTERLOCK OR ASTRAGAL

**8800 PVC
SLIDING GLASS
DOOR - IMPACT**

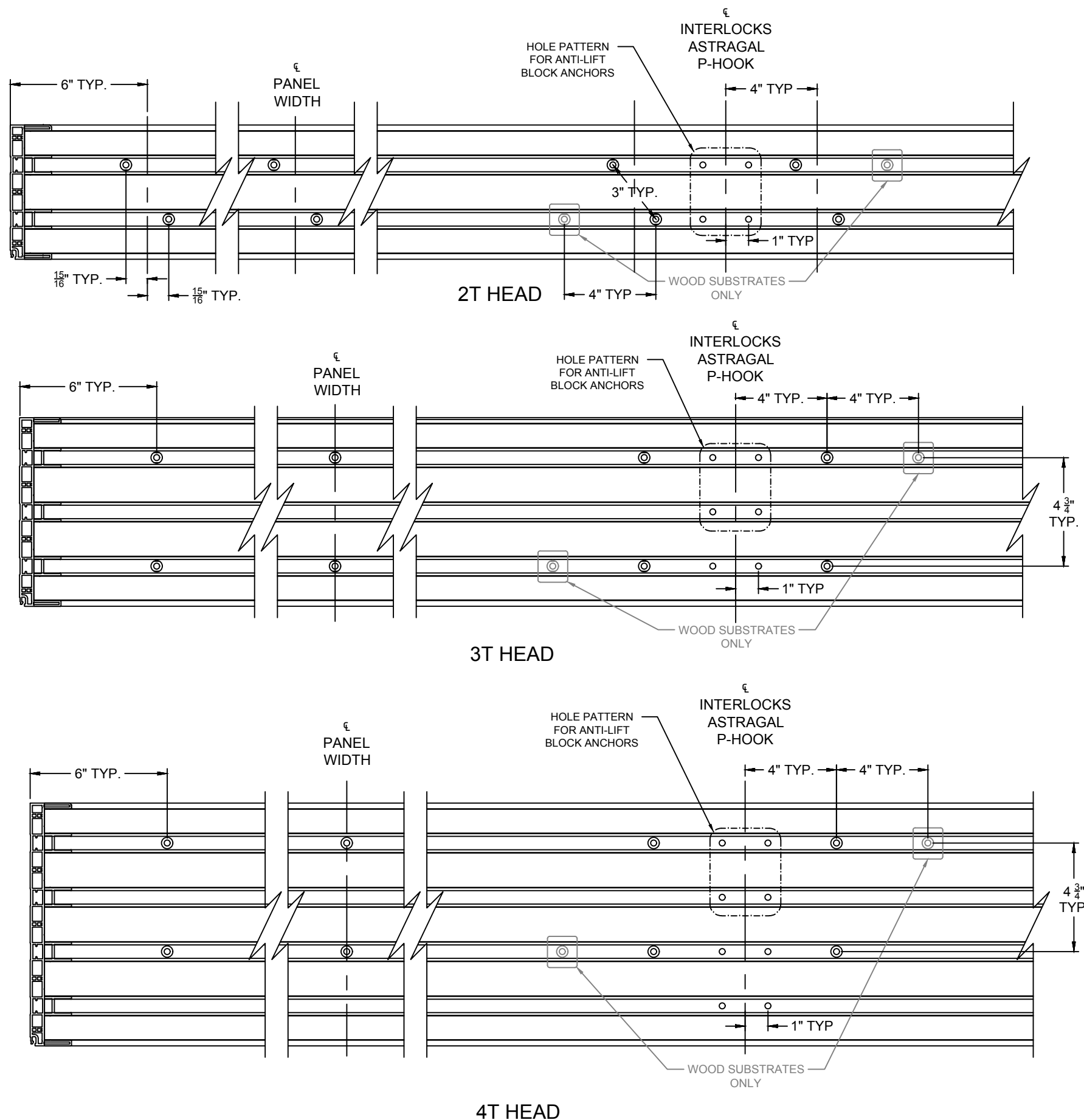

* CIRCLED ANCHOR LOCATIONS REQ'D ONLY IN WOOD INSTALLATIONS.

NOTE: C = CENTERLINE OF INTERLOCK OR ASTRAGAL

NO.	DESCRIPTION:	BY:	DATE:

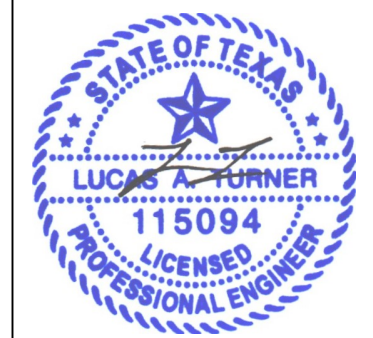

5/28/2020

LUCAS A. TURNER, P.E.
TX PE #115094
TBPE REG. #F-18075
2428 OLD NATCHEZ TRC TRL
CAMDEN, TN 38320
PH. 941-380-1574

SHEET DESCRIPTION:
**ANCHOR PATTERNS
(HEAD)**

DRAWN BY: BLZ	DATE: 05/17/16
DWG #: TDI-1152	REV.: -
SCALE: 1:5	SHEET 9 OF 11

**8800 PVC
SLIDING GLASS
DOOR - IMPACT**

NO.	DESCRIPTION	BY	DATE



5/28/2020

LUCAS A. TURNER, P.E.
TX PE #115094
TBPE REG. #F-18075
2428 OLD NATCHEZ TRC TRL
CAMDEN, TN 38320
PH. 941-380-1574

SHEET DESCRIPTION:
**INSTALLATION DETAILS
2 TRACK**

DRAWN BY: BLZ	DATE: 05/17/16
DWG #: TDI-1152	REV.: -
SCALE: 1:3	SHEET 10 OF 11

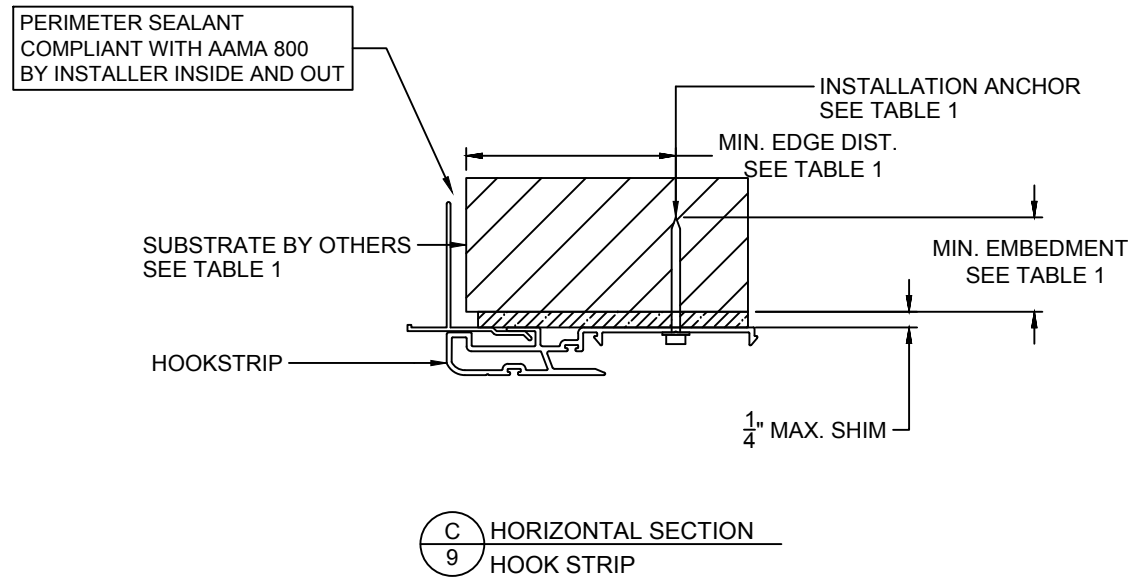
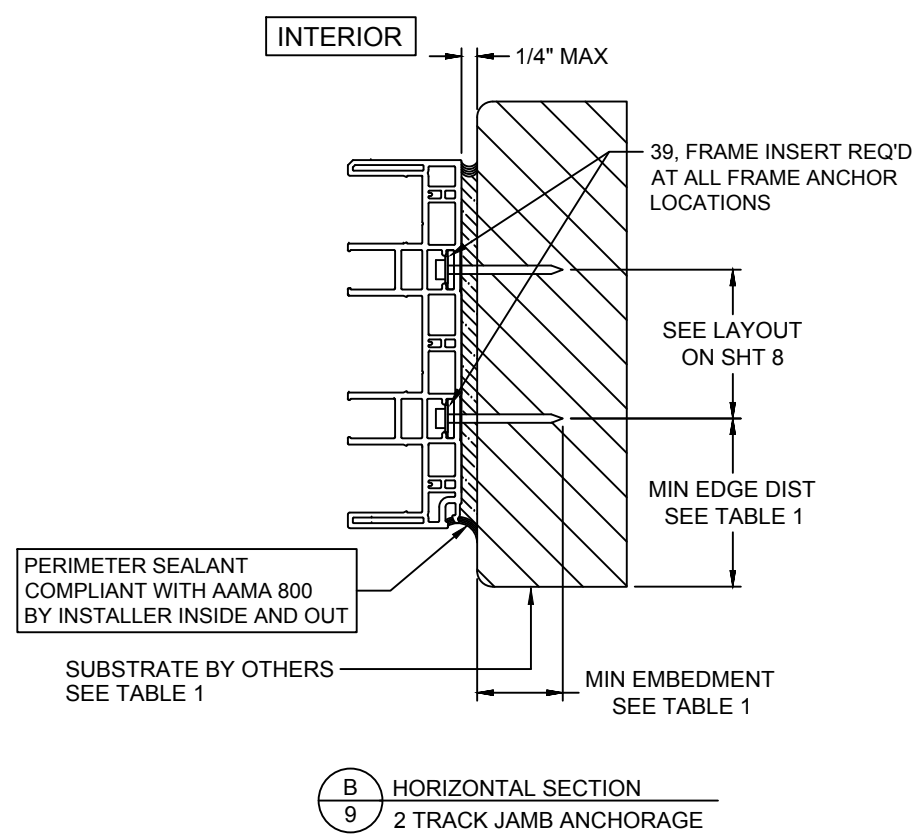
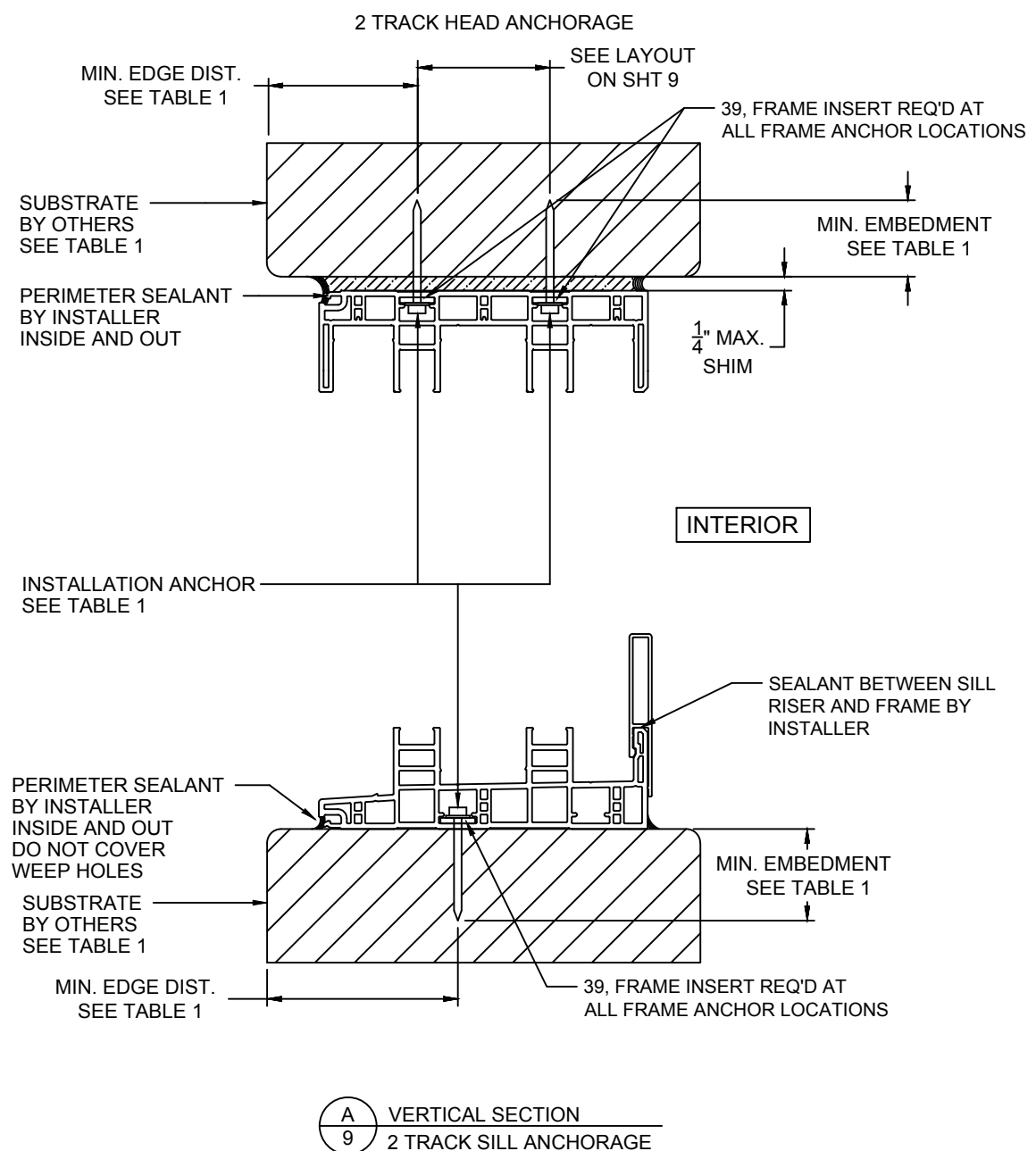

TABLE 1: APPROVED INSTALLATION FASTENERS

SUBSTRATE TYPE	ANCHOR TYPE	MIN. EMBEDMENT	MIN. EDGE DIST.
CONCRETE (2.0 KSI MIN.)	1/4" ITW TAPCON	1-1/2"	4"
CONCRETE (2.85 KSI MIN.)	1/4" ELCO ULTRACON	1-3/4"	2-1/2"
2X MIN. SOUTHERN PINE (G=0.55)	1/4" ITW TAPCON OR ELCO ULTRACON	1-3/8"	7/8"
2X MIN. SOUTHERN PINE (G=0.55)	#12 WOOD SCREW	1-3/8"	7/8"
16 GAUGE (0.060") MIN. STEEL STUD (33 KSI YIELD MIN)	#12-14 HILTI KWIK-FLEX OR ITW TEKS SELF-DRILLING SCREW	FULL THREAD THRU 0.060"	1/2"
1/8" ALUM. (6063-T5 MIN.) OR 1/8" STEEL (33 KSI MIN.)	#12 GRADE 5 SELF-TAPPING / DRILLING SCREW	FULL THREAD THRU 0.125"	1/2"
HOOKSTRIP OR JAMB FRAME ONLY: HOLLOW OR GROUT-FILLED CMU (ASTM C-90)	1/4" ELCO ULTRACON	1-3/4"	2-1/2"

8800 PVC SLIDING GLASS DOOR - IMPACT

NO.	DESCRIPTION	BY	DATE



5/28/2020

LUCAS A. TURNER, P.E.
 TX PE #115094
 TBPE REG. #F-18075
 2428 OLD NATCHEZ TRC TRL
 CAMDEN, TN 38320
 PH. 941-380-1574

SHEET DESCRIPTION:
**INSTALLATION DETAILS
 3 & 4 TRACK**

DRAWN BY: BLZ	DATE: 05/17/16
DWG #: TDI-1152	REV.: -
SCALE: 1:3	SHEET 11 OF 11

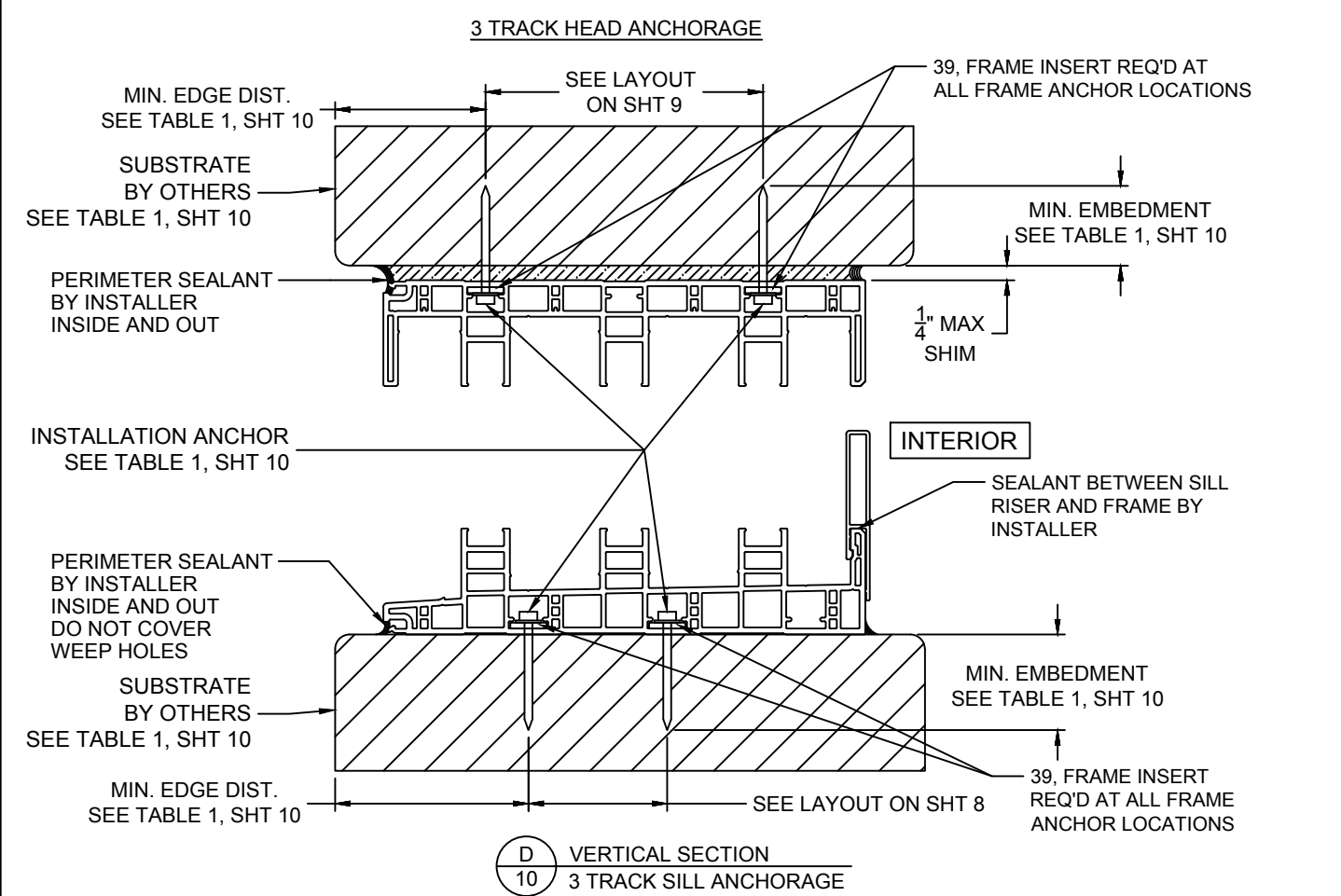

D VERTICAL SECTION
10 3 TRACK SILL ANCHORAGE

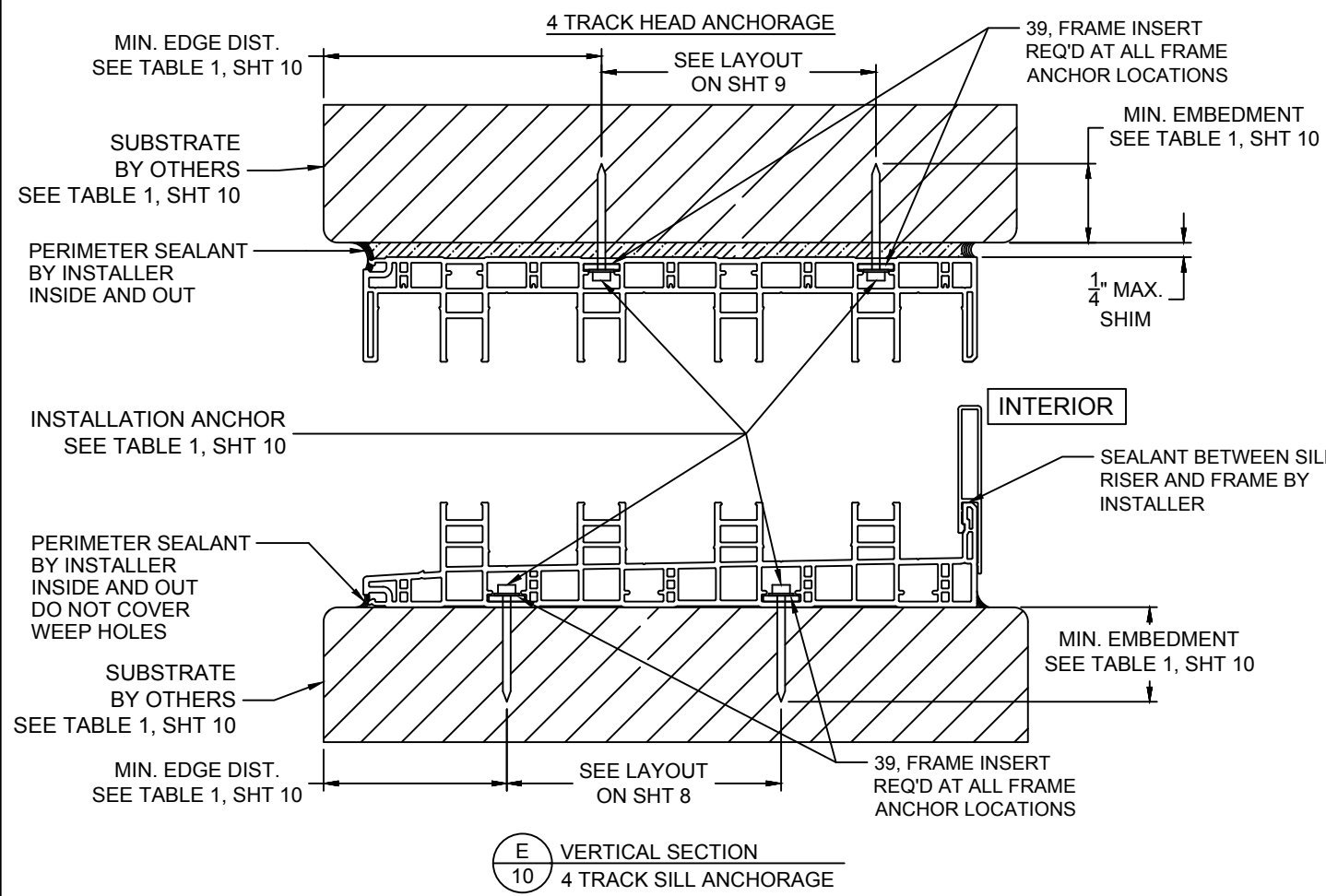

E VERTICAL SECTION
10 4 TRACK SILL ANCHORAGE

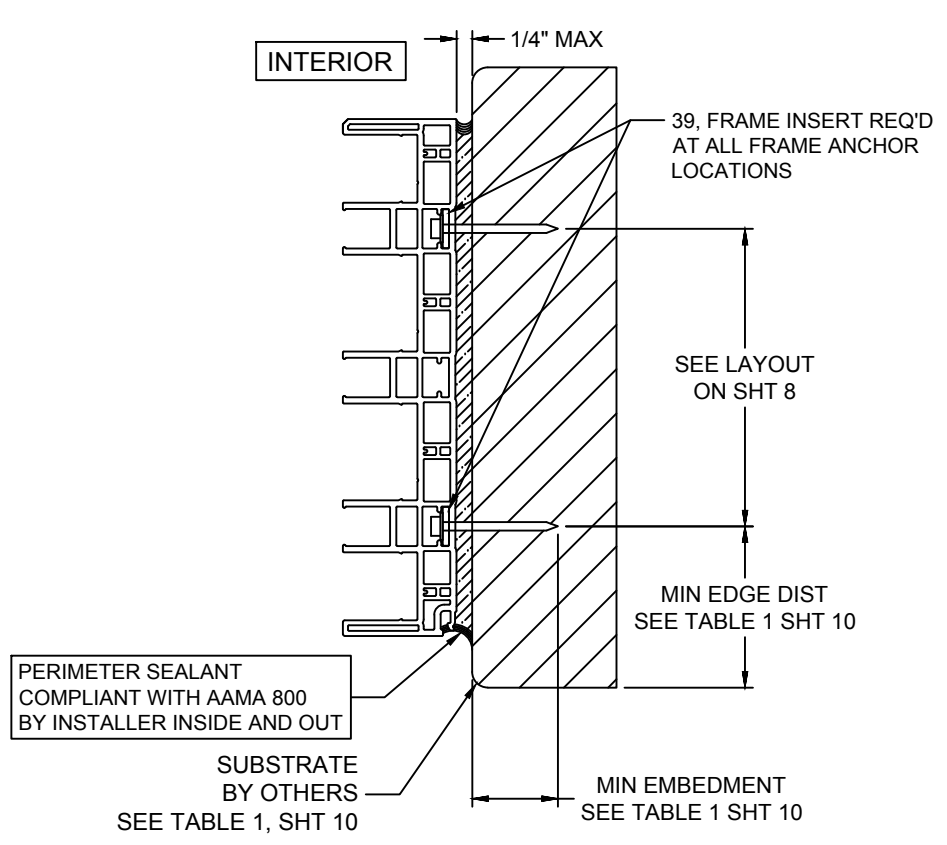

F HORIZONTAL SECTION
10 3 TRACK JAMB ANCHORAGE

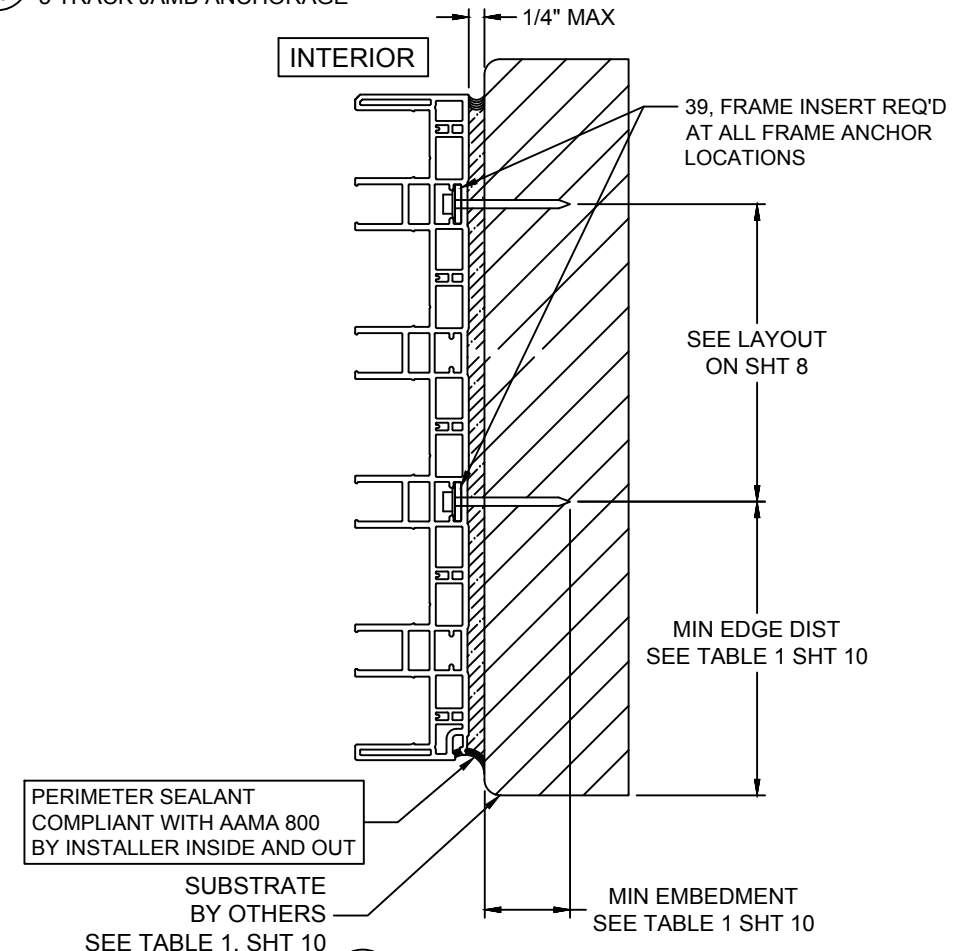

G HORIZONTAL SECTION
10 4 TRACK JAMB ANCHORAGE

REVISIONS