



GLAZED STEEL ENTRY DOOR DOUBLES w/ or w/out SIDELITES

**INSWING
"NON-IMPACT"**

EVALUATED FOR USE IN THE STATE OF TEXAS

The Steel Door system described herein complies with the 2018 International Residential Code (IRC), Sections R301 & R609 and the 2018 International Building Code (IBC), Sections 1404.13, 1609, 1709.5, 2403 and 2404 subject to the following conditions:

1. Anchors shall be as listed and spaced as shown in the details. Anchor embedment to base material shall be beyond wall dressing or stucco.
2. When used in areas requiring wind-borne debris protection this product is required to be protected with an impact resistant covering that complies with Section R301.2.1.2 of the IRC and Section 1609.1.2 of the IBC.
3. Allowable design pressure requirements must be equal to or less than the design pressure rating shown in the design pressure chart, sheet 1 of this drawing.
4. Conditions not covered by this drawing are subject to further engineering analysis.

TABLE OF CONTENTS

SHEET #	DESCRIPTION
1	Typical Elevations, Design Pressures & General Notes
2	Door Panel Details
3	Sidelite Panel & Glazing Details
4	Elevations
5	Horizontal & Vertical Cross Sections
6	Horizontal Cross Sections
7	Vertical Cross Sections
8	Frame Anchoring & Hardware Details
9	Astragal Details
10	Bill of Materials & Components

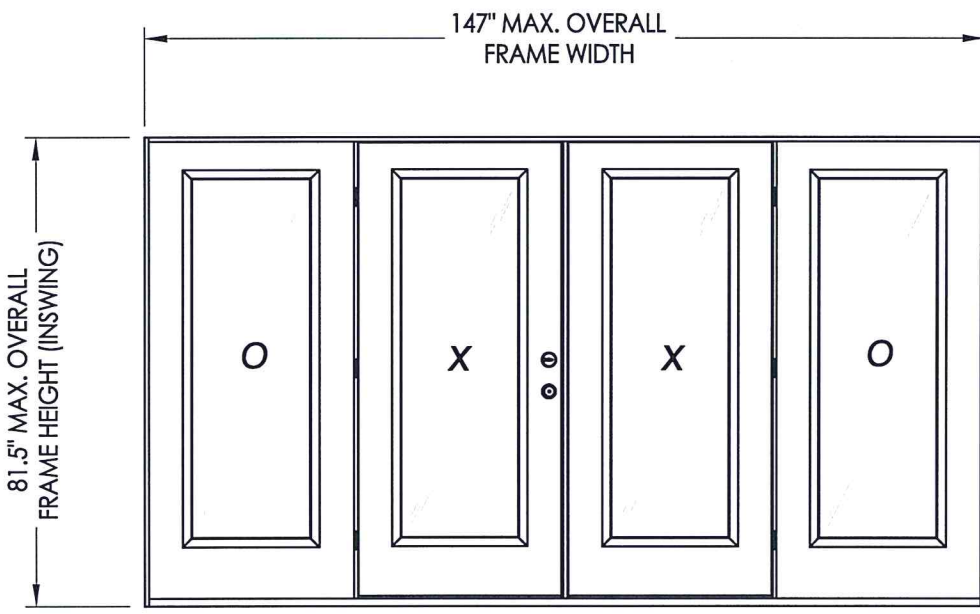
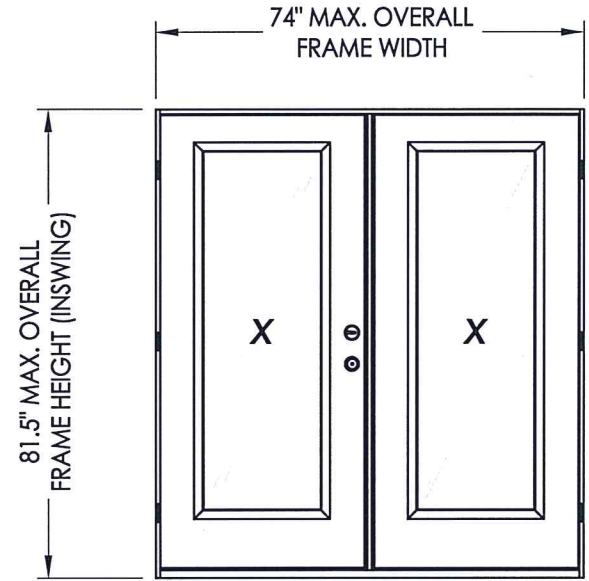

CONFIGURATION	MAX. FRAME DIMENSION	DESIGN PRESSURE (PSF) INSWING	
		POSITIVE	NEGATIVE
XX	74.0" x 81.5"	+30.0	-40.0
OXXO	147.0" x 81.5"	+30.0	-40.0



Documents Prepared By: Lyndon F. Schmidt, P.E.
TEXAS P.E. #104123

RW BUILDING CONSULTANTS, INC.
P.O. Box 230 Vairico FL 33595
Phone No.: 813.659.9197

TEXAS BOARD OF PROFESSIONAL ENGINEERS
CERTIFICATE OF REGISTRATION # F-11852

PRODUCT: DOORSCAPES STEEL DOOR

PART OR ASSEMBLY: TYPICAL ELEVATION, DESIGN PRESSURES & GENERAL NOTES

NO.	DATE	BY	REVISIONS
1	10/28/21	LFS	UPDATE TO 2018 IBC/IRC CODE

DATE: 5/06/19

SCALE: N.T.S.

DWG. BY: MT

CHK. BY: LFS

DRAWING NO.: TX-4933

SHEET 1 OF 10

Z:\Clients\Doorscapes\B - Texas Dept of Ins\TDI - DR 1059 Steel Non-Impact\C - Drawings\TX-4932-33.dwg

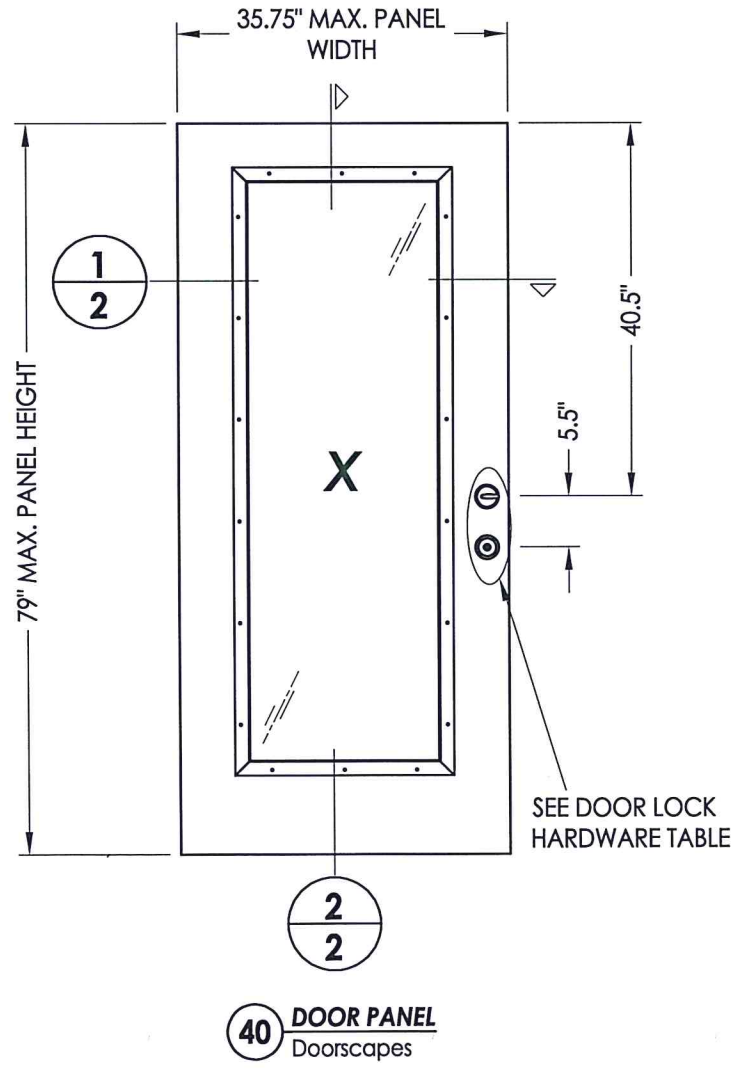
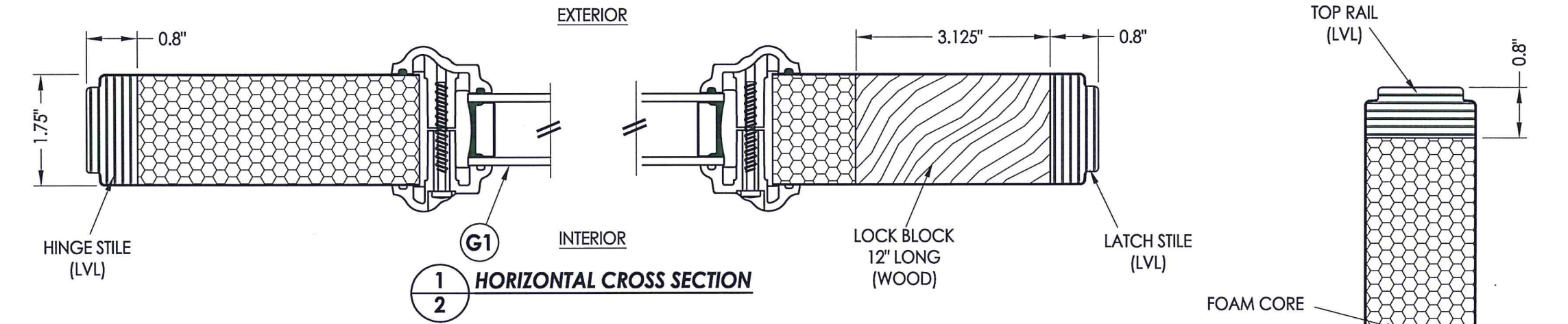

HARDWARE TABLE	
MANUFACTURER	MODEL
YALE	KNOB: YE SERIES (10) DEADBOLT: YE SERIES (82E)

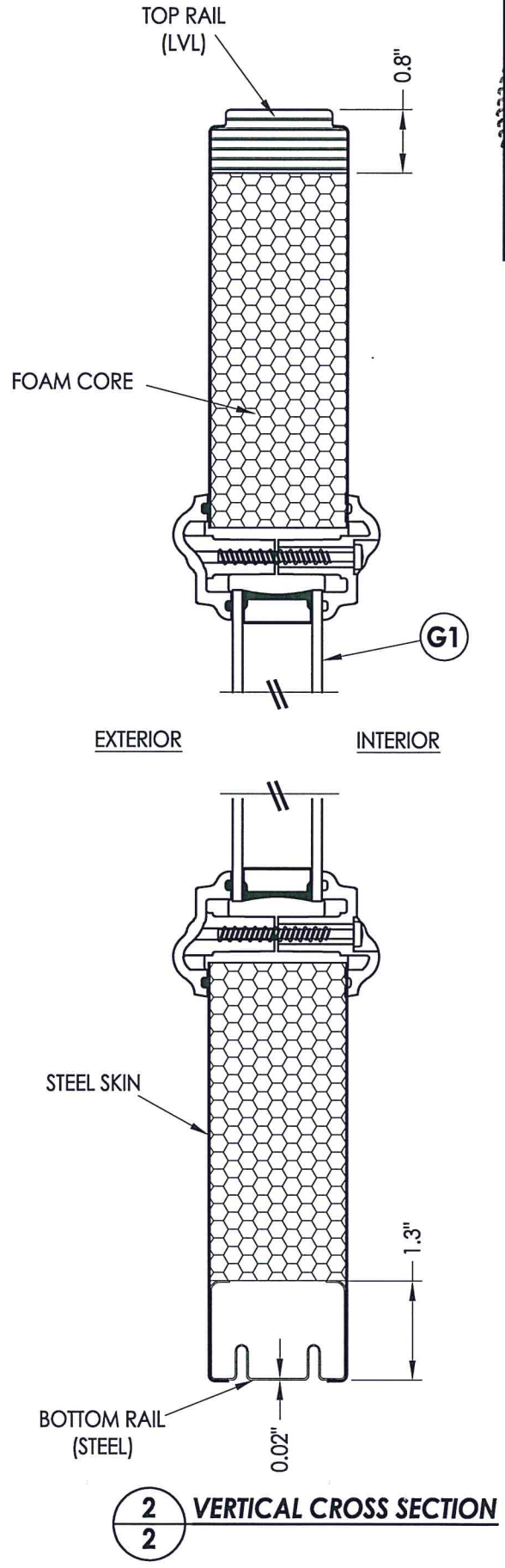

Documents Prepared By: Lyndon F. Schmidt, P.E.
 TEXAS P.E. #104123

RW BUILDING CONSULTANTS, INC.
 P.O. Box 230 Valrico FL 33595
 Phone No.: 813.659.9197

TEXAS BOARD OF PROFESSIONAL ENGINEERS
 CERTIFICATE OF REGISTRATION # F-11852

PRODUCT:	DOORSCAPES STEEL DOOR	
PART OR ASSEMBLY:	DOOR PANEL DETAILS	
NO.	DATE	BY
1	10/28/21	LFS
REVISIONS		
DATE:	5/06/19	
SCALE:	N.T.S.	
DWG. BY:	MT	
CHK. BY:	LFS	
DRAWING NO.:	TX-4933	
SHEET	2 of 10	

STEEL SKIN: 0.020" MIN. THK.
 FOAM CORE: POLYSTYRENE - 2 PCF MIN.

Z:\Clients\Doorscapes\B - Texas Dept of Ins\TDI - DR 1059 Steel Non-Impact\C - Drawings\TX-4932-33.dwg

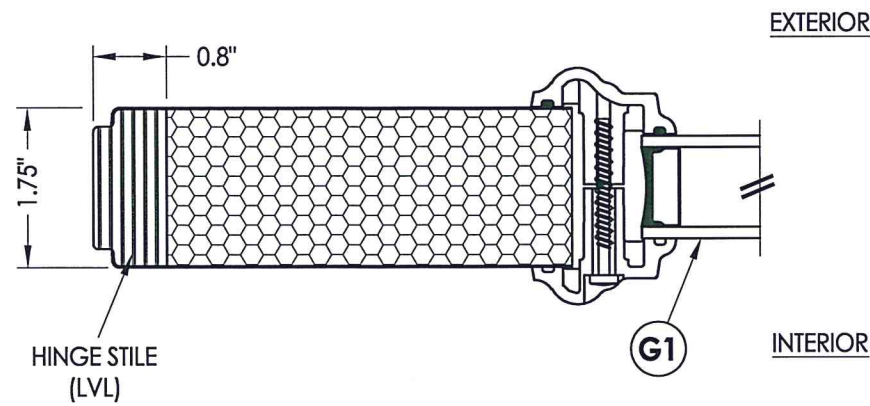

1
3 HORIZONTAL CROSS SECTION

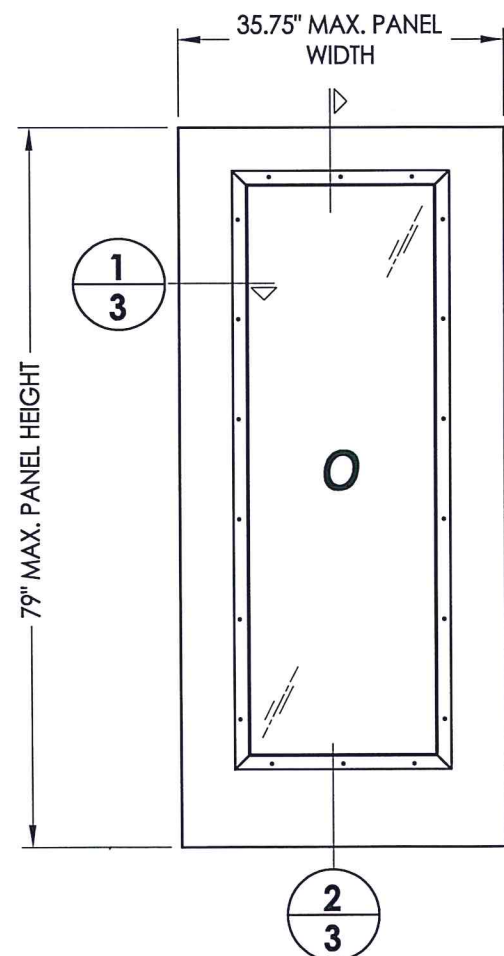

50 SIDELITE PANEL
Doorscapes

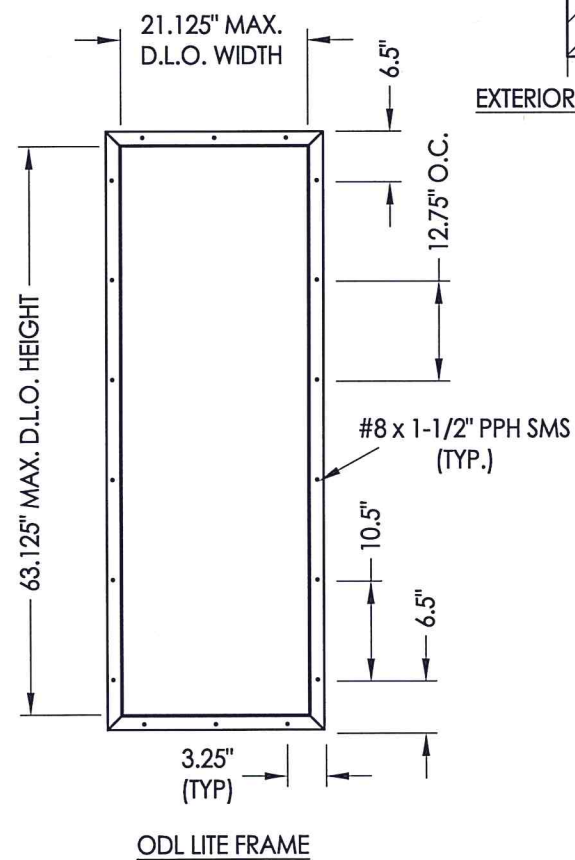

ODL LITE FRAME

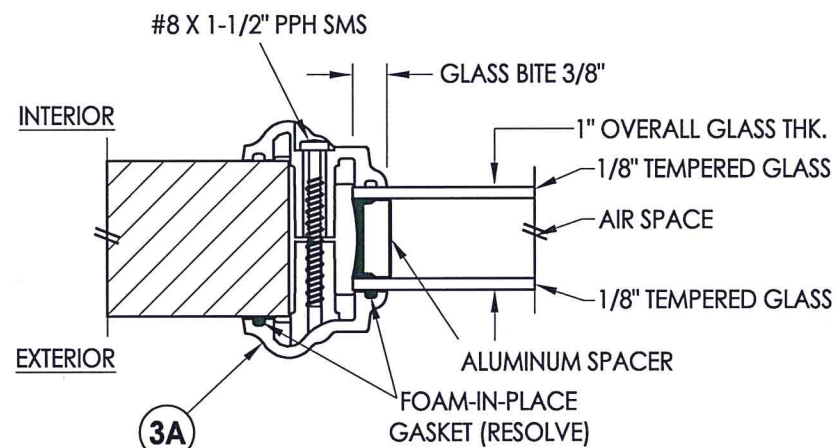

G1 GLAZING DETAIL
ODL LITE FRAME

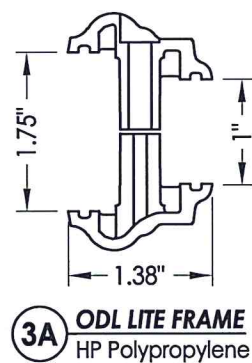

3A ODL LITE FRAME
HP Polypropylene

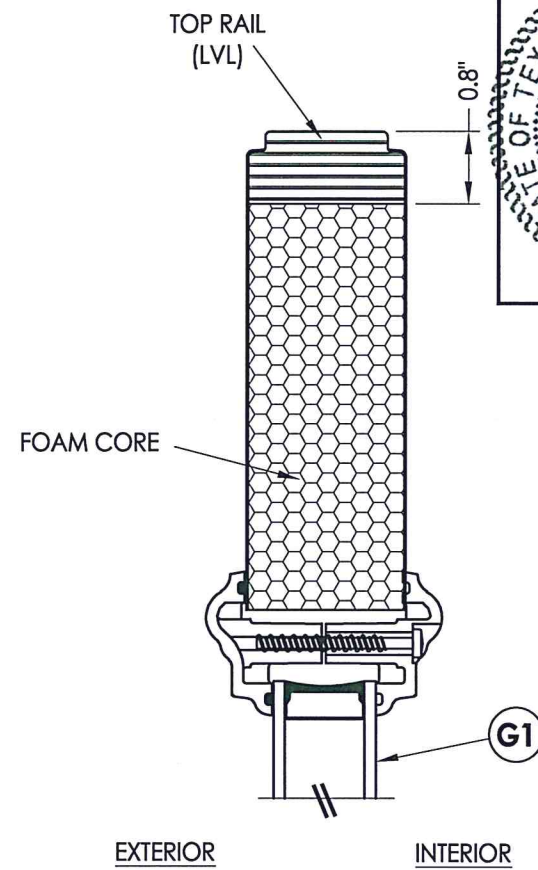

2
3 VERTICAL CROSS SECTION

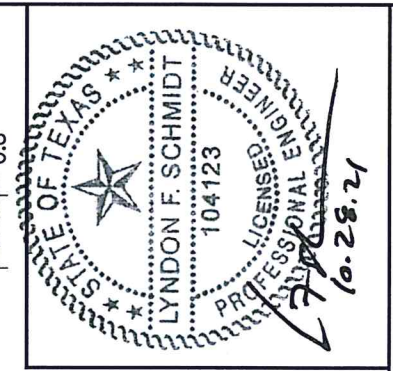

Documents Prepared By: Lyndon F. Schmidt, P.E.
TEXAS P.E. #104123

RW BUILDING CONSULTANTS, INC.
P.O. Box 230 Vairico FL 33595
Phone No.: 813.659.9197

TEXAS BOARD OF PROFESSIONAL ENGINEERS
CERTIFICATE OF REGISTRATION # F-11852

PRODUCT:	DOORSCAPES STEEL DOOR	
PART OR ASSEMBLY:	SIDELITE PANEL & GLAZING DETAILS	
DATE:	5/06/19	
SCALE:	N.T.S.	
DWG. BY:	MT	
CHK. BY:	LFS	
DRAWING NO.:	TX-4933	
SHEET	3 of 10	
NO.	DATE	REVISIONS
1	10/28/21	UPDATE TO 2018 IBC/IRC CODE
		LFS
		BY

STEEL SKIN: 0.020" MIN. THK.
FOAM CORE: POLYSTYRENE - 2 PCF MIN.

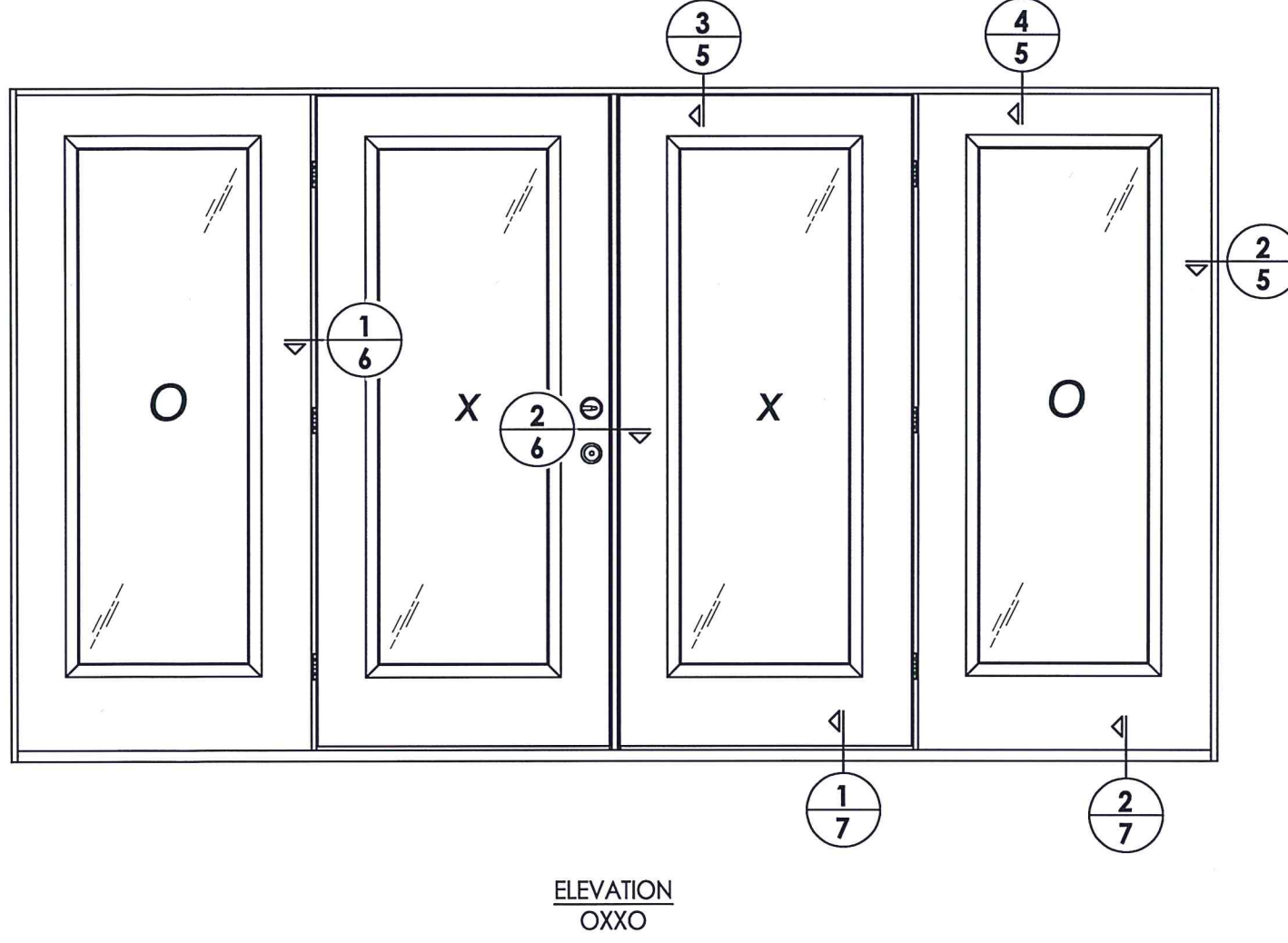
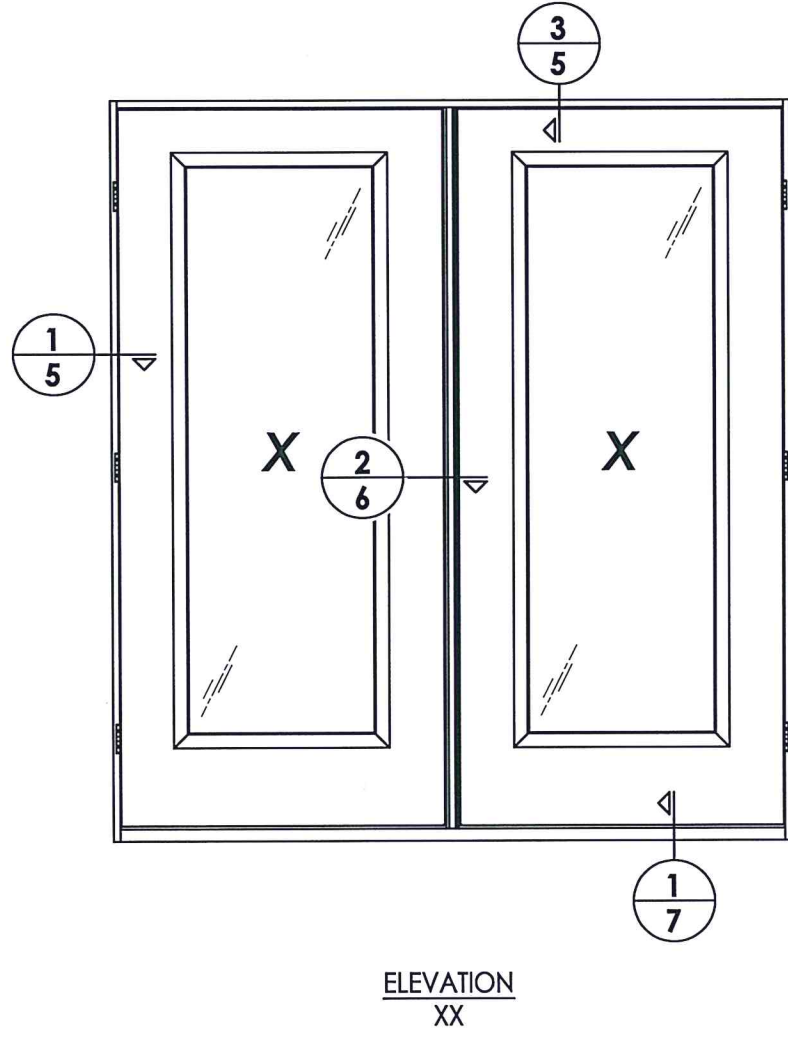

Documents Prepared By: Lyndon F. Schmidt, P.E.
TEXAS P.E. #104123

RW BUILDING CONSULTANTS, INC.
P.O. Box 230 Valrico FL, 33595
Phone No.: 813.659.9197

TEXAS BOARD OF PROFESSIONAL ENGINEERS
CERTIFICATE OF REGISTRATION # F-11852

PRODUCT: DOORSCAPES
STEEL DOOR

PART OR ASSEMBLY:
ELEVATIONS

REVISIONS	
NO.	DATE
1	10/28/21
	UPDATE TO 2018 IBC/IRC CODE
	LFS
	BY

DATE: 5/06/19
SCALE: N.T.S.
DWG. BY: MT
CHK. BY: LFS
DRAWING NO.: TX-4933
SHEET 4 OF 10

Z:\Clients\Doorscapes\B - Texas Dept of Ins\TDI - DR 1059 Steel Non-Impact\C - Drawings\TX-4932-33.dwg

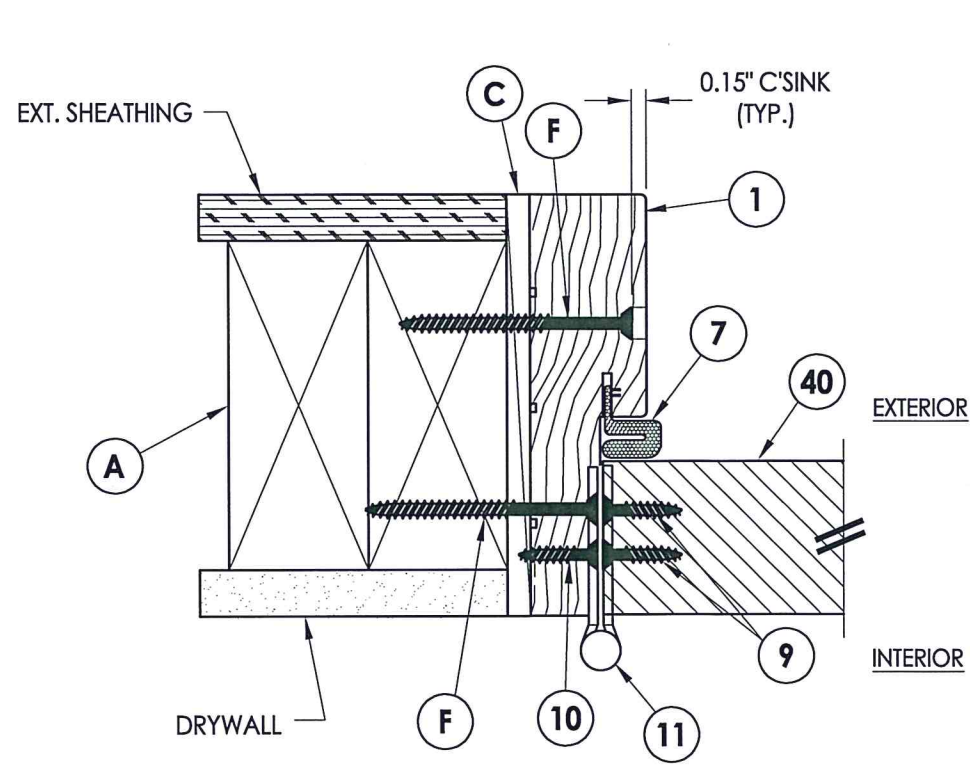

1
5 HORIZONTAL CROSS SECTION

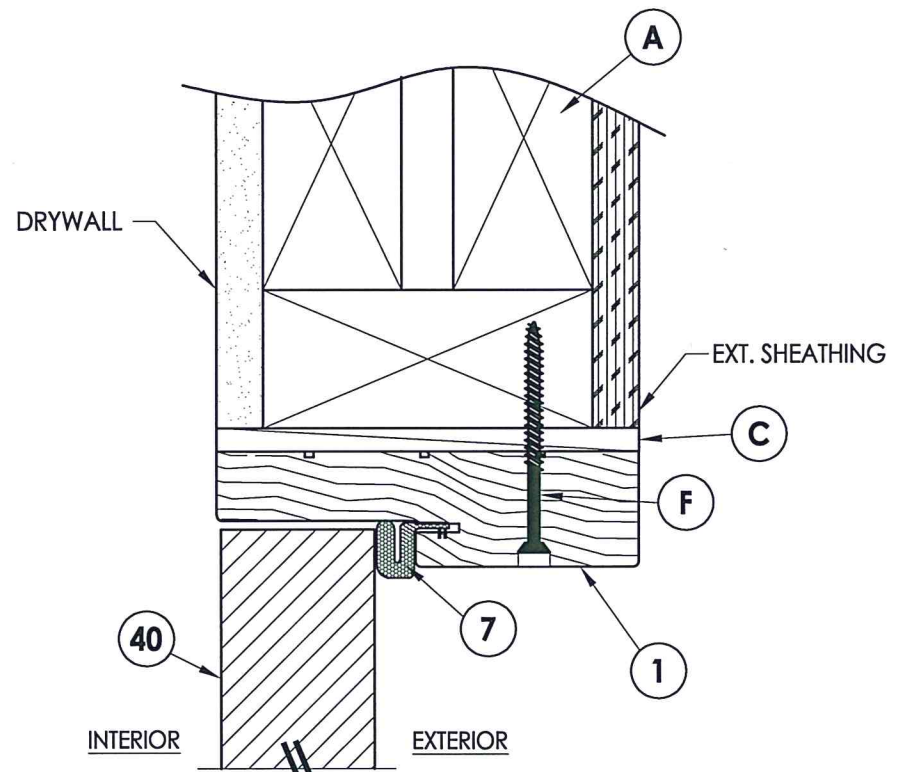

3
5 VERTICAL CROSS SECTION

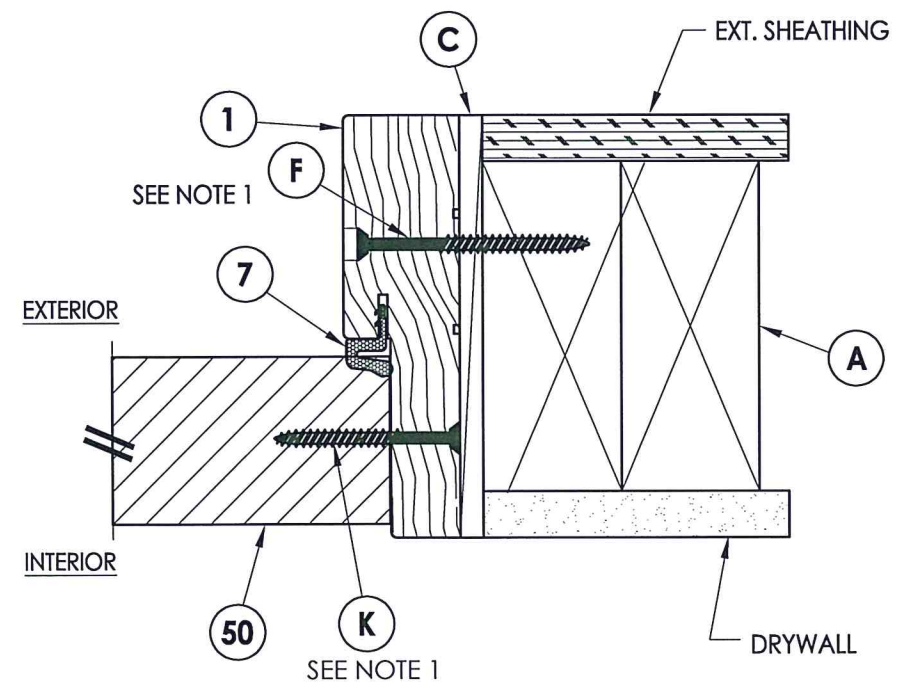

2
5 HORIZONTAL CROSS SECTION

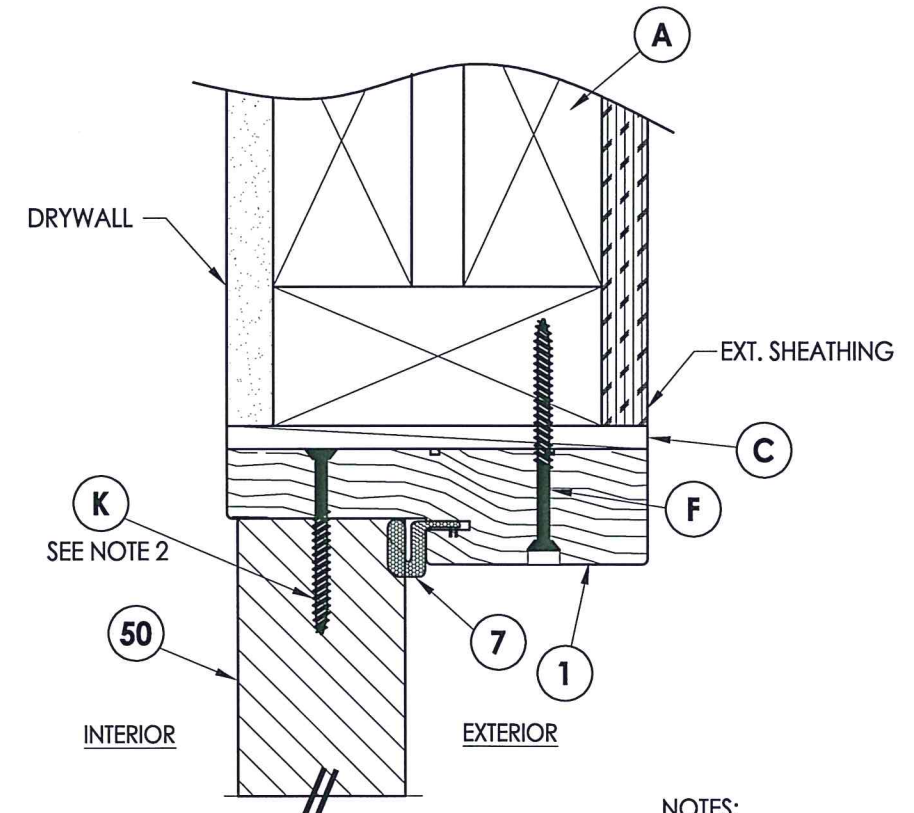

4
5 VERTICAL CROSS SECTION

- NOTES:**
- Sidelite attached @ 6" from each end plus 4 more screws equally spaced between (6 screws total per jamb).
 - Sidelite attached @ 3" from each end (2 screws total @ head).



Documents Prepared By: Lyndon F. Schmidt, P.E.
TEXAS P.E. #104123

RW BUILDING CONSULTANTS, INC.
P.O. Box 230 Valrico FL, 33595
Phone No.: 813.659.9197

TEXAS BOARD OF PROFESSIONAL ENGINEERS
CERTIFICATE OF REGISTRATION # F-11852

PRODUCT: DOORSCAPES STEEL DOOR	
PART OR ASSEMBLY: HORIZONTAL & VERTICAL CROSS SECTIONS	
NO.	DATE
1	10/28/21
UPDATE TO 2018 IBC/IRC CODE	
LFS	BY
REVISIONS	
DATE: 5/06/19	
SCALE: N.T.S.	
DWG. BY: MT	
CHK. BY: LFS	
DRAWING NO.: TX-4933	
SHEET 5 OF 10	

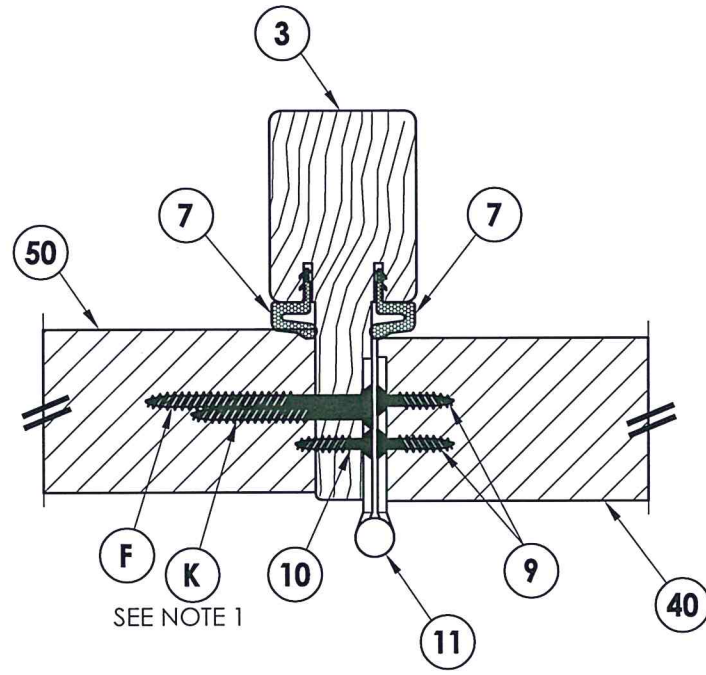

1
6 HORIZONTAL CROSS SECTION

EXTERIOR

INTERIOR

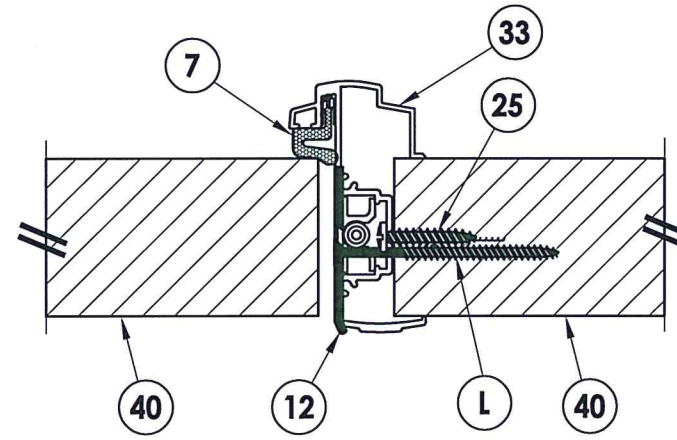

2
6 HORIZONTAL CROSS SECTION

NOTE:

- Sidelite attached w/ 1 screw equally spaced between each hinge (2 screws total per mullion).

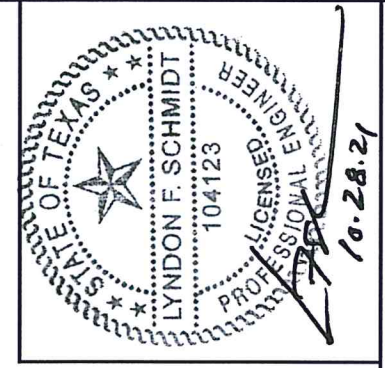

Documents Prepared By: Lyndon F. Schmidt, P.E.
TEXAS P.E. #104123

RW BUILDING CONSULTANTS, INC.
P.O. Box 230 Valrico FL 33595
Phone No.: 813.659.9197
TEXAS BOARD OF PROFESSIONAL ENGINEERS
CERTIFICATE OF REGISTRATION # F-11852

PRODUCT: DOORSCAPES STEEL DOOR
PART OR ASSEMBLY: HORIZONTAL CROSS SECTIONS

NO.	DATE	DESCRIPTION	BY
1	10/28/21	UPDATE TO 2018 IBC/IRC CODE	LFS

DATE: 5/06/19
SCALE: N.T.S.
DWG. BY: MT
CHK. BY: LFS
DRAWING NO.: TX-4933
SHEET 6 OF 10

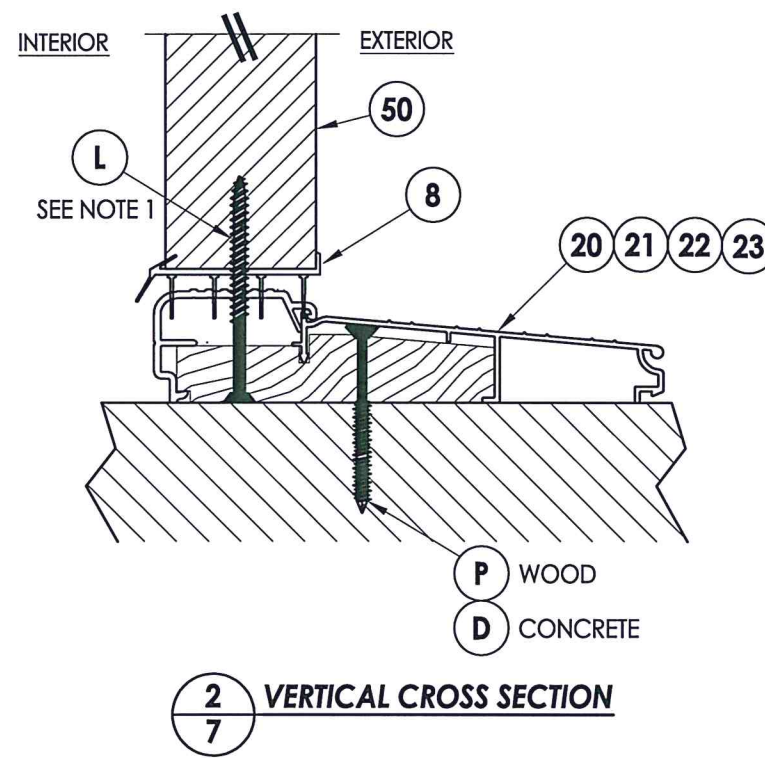
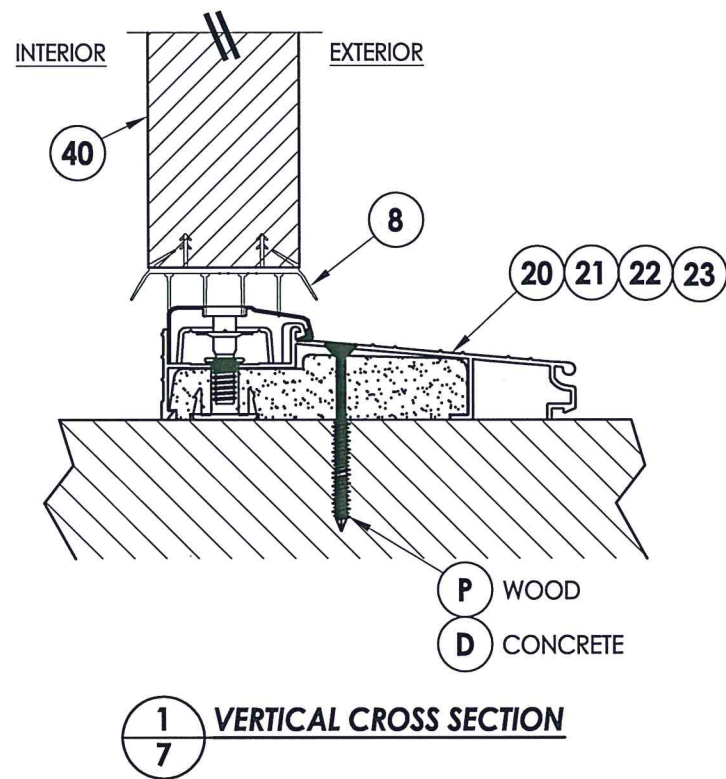

NOTE:
1. Sidelite attached @ 3" from each end (2 screws total @ sill).

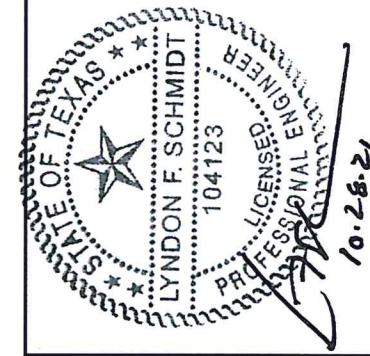

Documents Prepared By: Lyndon F. Schmidt, P.E.
TEXAS P.E. #104123

RW BUILDING CONSULTANTS, INC.
P.O. Box 230 Valrico FL, 33595
Phone No.: 813.659.9197
TEXAS BOARD OF PROFESSIONAL ENGINEERS
CERTIFICATE OF REGISTRATION # F-11852

PRODUCT: DOORSCAPES STEEL DOOR	
PART OR ASSEMBLY: VERTICAL CROSS SECTIONS	
NO.	DATE
1	10/28/21
UPDATE TO 2018 IBC/IRC CODE	
LFS	BY
REVISIONS	
DATE: 5/06/19	
SCALE: N.T.S.	
DWG. BY: MT	
CHK. BY: LFS	
DRAWING NO.: TX-4933	
SHEET 7 of 10	

Z:\Clients\Doorscapes\B - Texas Dept of Ins\TDI - DR 1059 Steel Non-Impact\C - Drawings\TX-4932-33.dwg

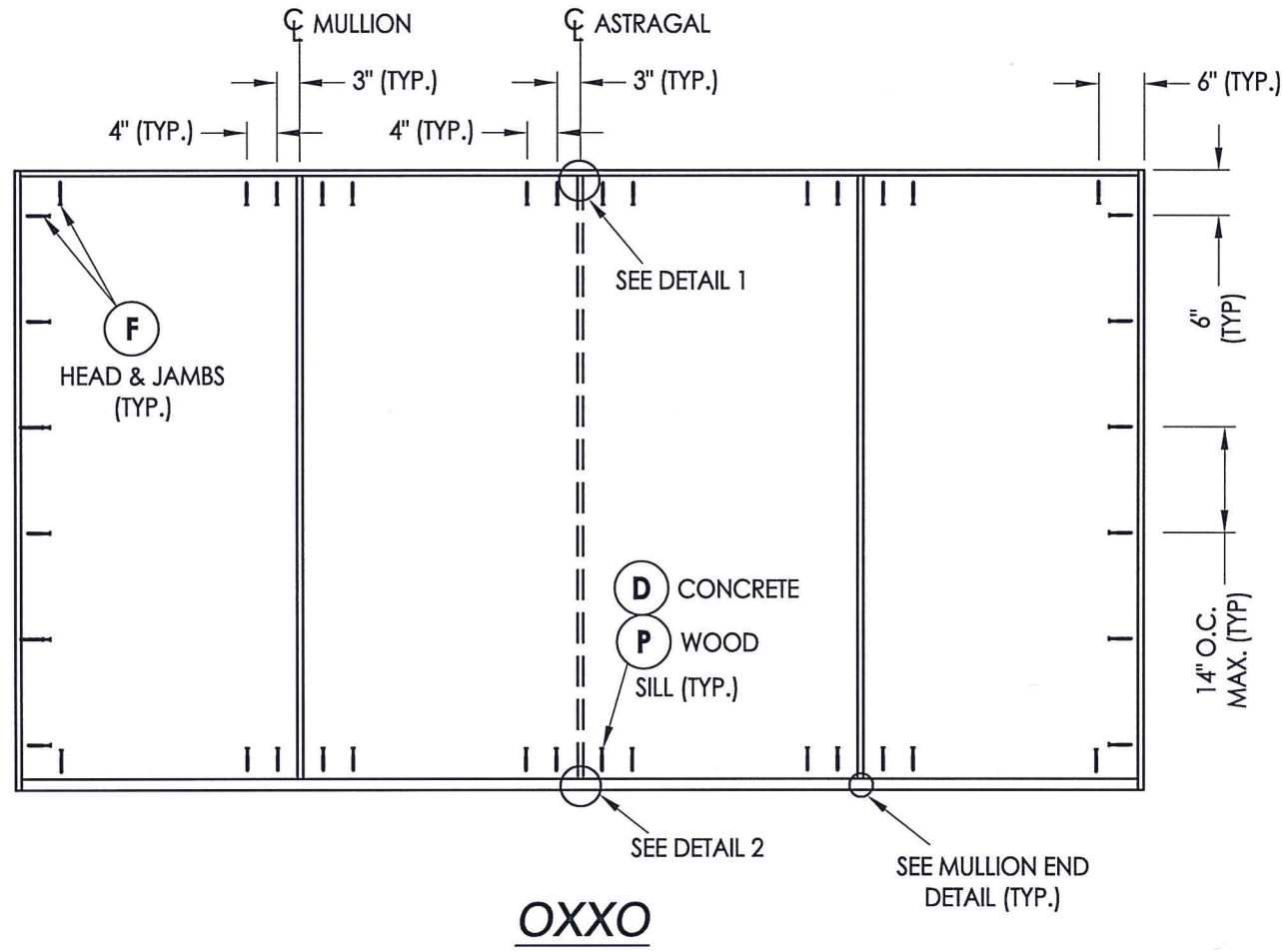
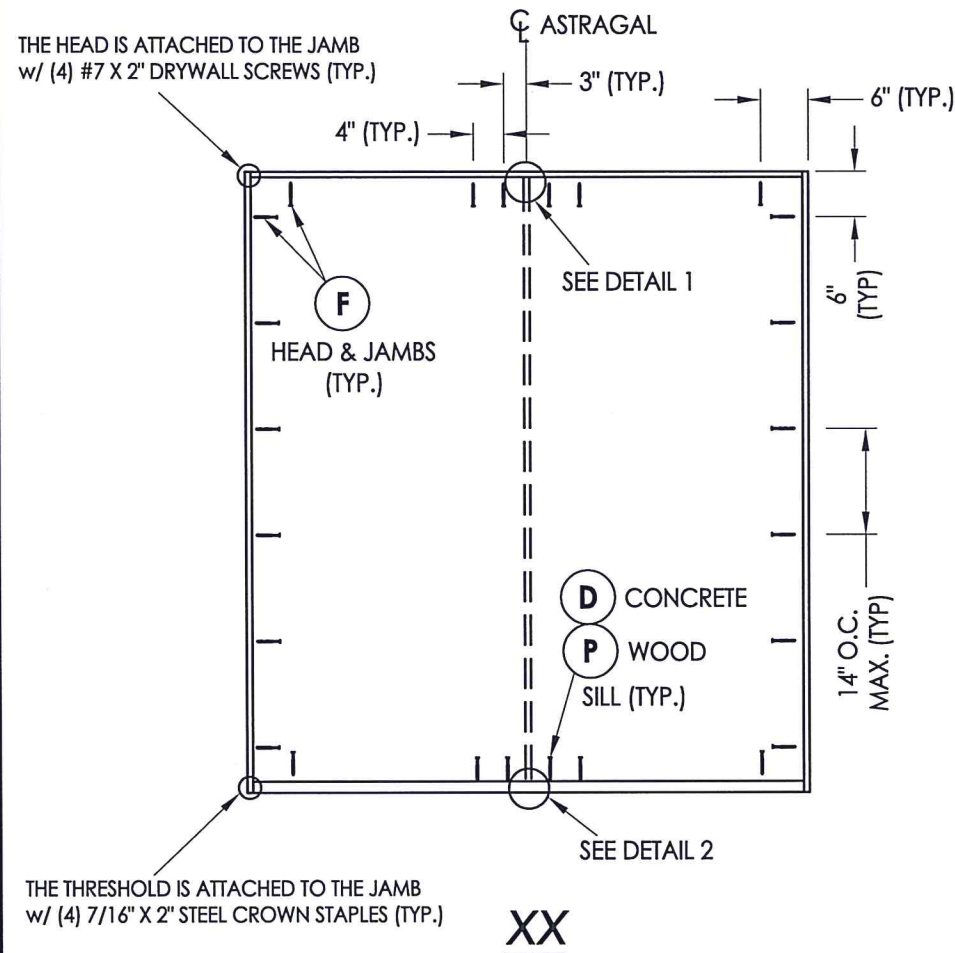

FRAME ANCHORING

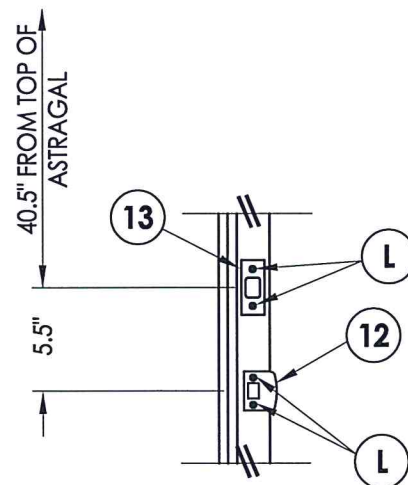
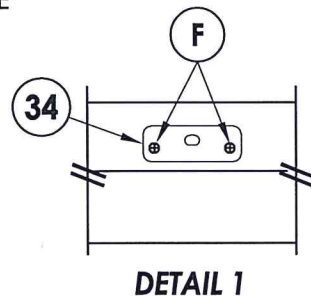
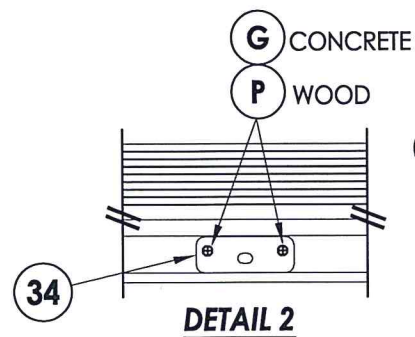
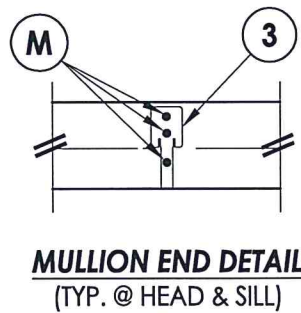

LATCH & DEADBOLT STRIKE DETAILS

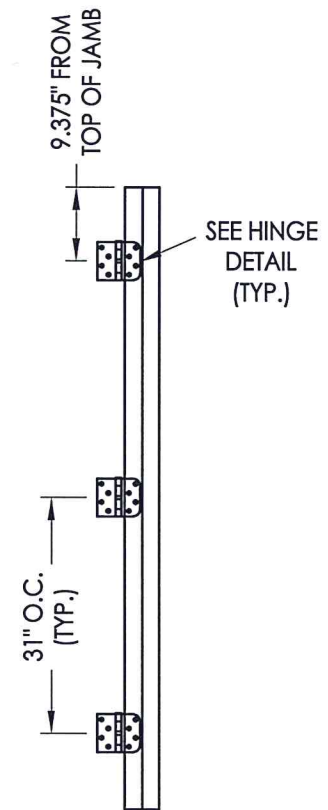
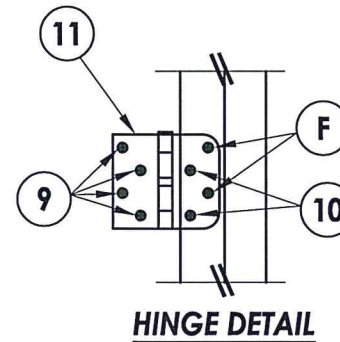

HINGE JAMB

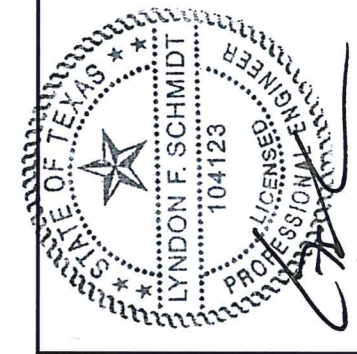

Documents Prepared By: Lyndon F. Schmidt, P.E.
TEXAS P.E. #104123

RW BUILDING CONSULTANTS, INC.
P.O. Box 230 Valrico FL 33595
Phone No.: 813.659.9197
TEXAS BOARD OF PROFESSIONAL ENGINEERS
CERTIFICATE OF REGISTRATION # F-11852

PRODUCT:	DOORSCAPES STEEL DOOR	
PART OR ASSEMBLY:	FRAME ANCHORING & HARDWARE DETAILS	
NO.	DATE	BY
1	10/28/21 UPDATE TO 2018 IBC/IRC CODE	LFS
REVISIONS		
DATE:	5/06/19	
SCALE:	N.T.S.	
DWG. BY:	MT	
CHK. BY:	LFS	
DRAWING NO.:	TX-4933	
SHEET	8	OF 10

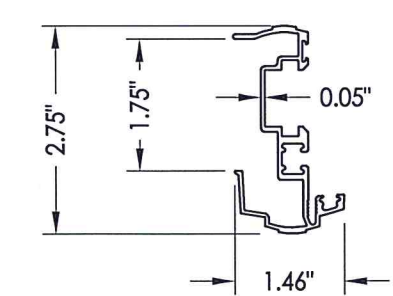
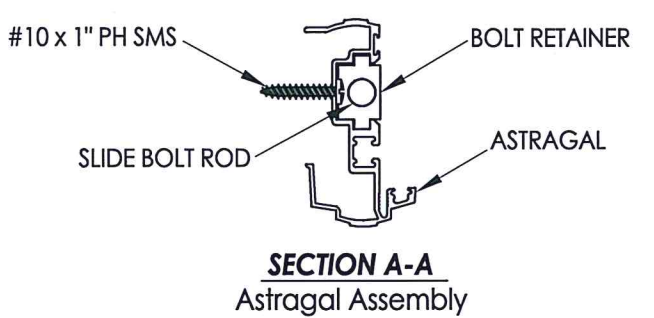
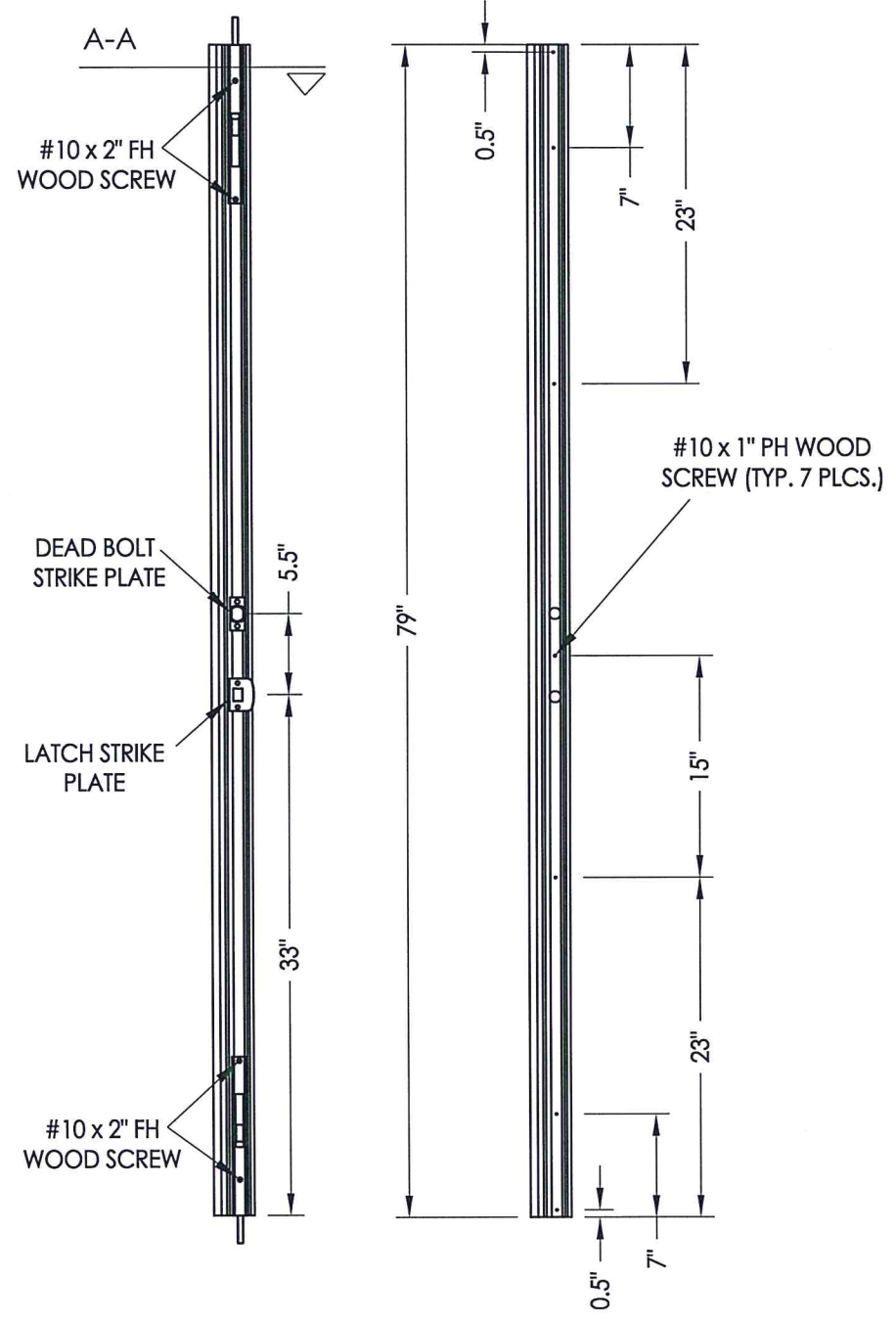

33 HURRICANE "T" ASTRAGAL by AFCO
Aluminum

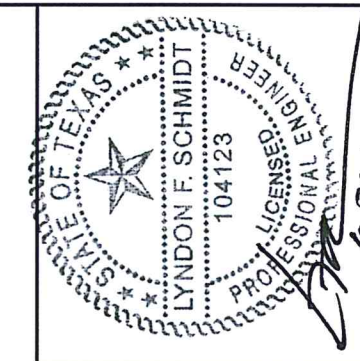
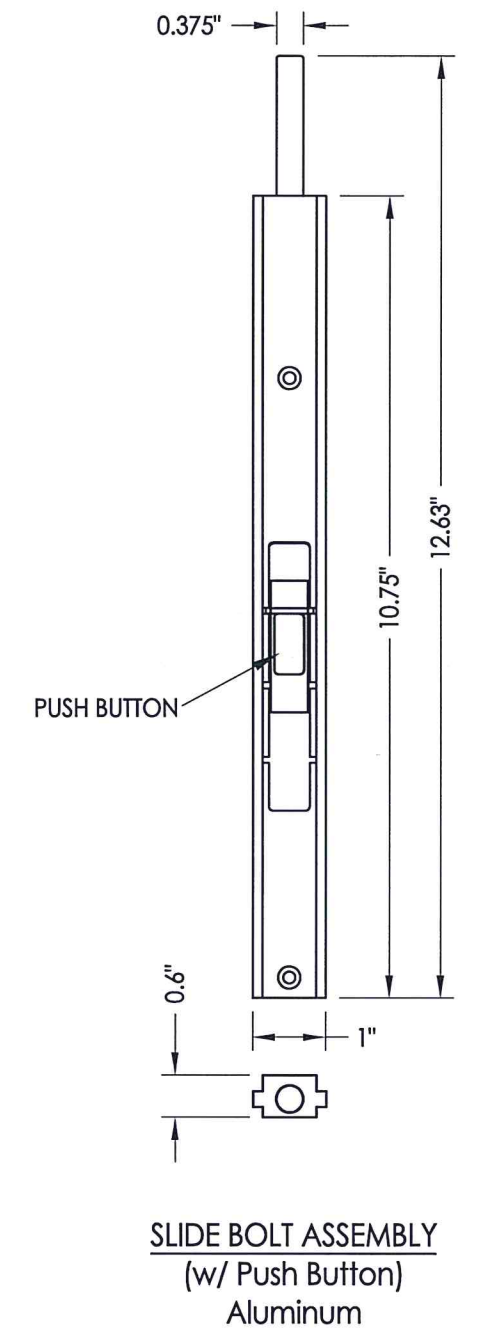

Documents Prepared By: Lyndon F. Schmidt, P.E.
TEXAS P.E. #104123

R.W. BUILDING CONSULTANTS, INC.
P.O. Box 230 Valrico FL 33595
Phone No.: 813.659.9197

TEXAS BOARD OF PROFESSIONAL ENGINEERS
CERTIFICATE OF REGISTRATION # F-11852

PRODUCT:	DOORSCAPES STEEL DOOR	
PART OR ASSEMBLY:	ASTRAGAL DETAILS	
NO.	DATE	REVISIONS
1	10/28/21	UPDATE TO 2018 IBC/IRC CODE
LFS		BY
DATE: 5/06/19		
SCALE: N.T.S.		
DWG. BY: MT		
CHK. BY: LFS		
DRAWING NO.: TX-4933		
SHEET 9 OF 10		

Z:\Clients\DoorScapes\B - Texas Dept of Ins\TDI - DR 1059 Steel Non-Impact\C - Drawings\TX-4932-33.dwg

BILL OF MATERIALS

ITEM #	DESCRIPTION	MATERIAL
A	2X FRAMING (G >= 0.42)	WOOD
C	1/4" MAX. SHIM SPACE	-
D	1/4" Ø PFH DeWALT OR ITW CONCRETE SCREW (1-3/4" MIN. EMBEDMENT)	STEEL
F	#10 X 2-1/2" PFH WOOD SCREW (1.15" MIN. EMBEDMENT)	STEEL
G	3/16" Ø PFH ITW CONCRETE SCREW (1-3/4" MIN. EMB.)	STEEL
K	#10 X 2" PFH WOOD SCREW	STEEL
L	#8 X 2-1/2" PFH WOOD SCREW	STEEL
M	#7 X 2-1/2" DRYWALL SCREW	STEEL
P	#10 PFH WOOD SCREW (1-1/2" MIN. EMB.)	STEEL
1	FINGER JOINT PINE JAMB (G >= 0.42)	WOOD
3	INTEGRAL MULLION (PINE, G >= 0.42)	WOOD
7	WEATHERSTRIP	FOAM
8	DOOR/SIDELITE BOTTOM SWEEP	VINYL
9	#9 X 1" PFH WOOD SCREW	STEEL
10	#10 X 3/4" PFH WOOD SCREW	STEEL
11	4" X 4" BUTT HINGE	STEEL
12	LATCH STRIKE PLATE	STEEL
13	DEADBOLT STRIKE PLATE	STEEL
20	INSWING THRESHOLD (AFCO A-125)	ALUM/WOOD
21	INSWING THRESHOLD (AFCO A-125)	ALUM/COMP
22	INSWING THRESHOLD (AFCO A-276)	ALUM/WOOD
23	INSWING THRESHOLD (AFCO A-280)	ALUM/WOOD
25	#10 X 1" PH SMS	STEEL
33	ALUMINUM ASTRAGAL (AFCO)	ALUM
34	ASTRAGAL STRIKE PLATE	STEEL
40	DOOR PANEL - SEE DOOR PANEL DETAIL SHEET FOR DETAILS	-
50	SIDELITE PANEL - SEE SIDELITE PANEL DETAIL SHEET FOR DETAILS	-

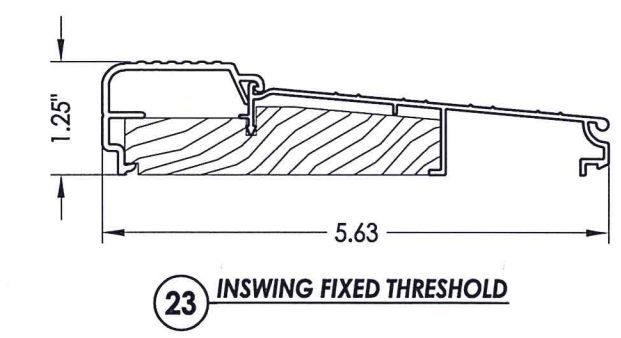
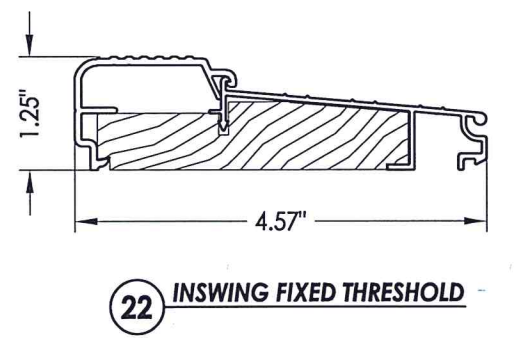
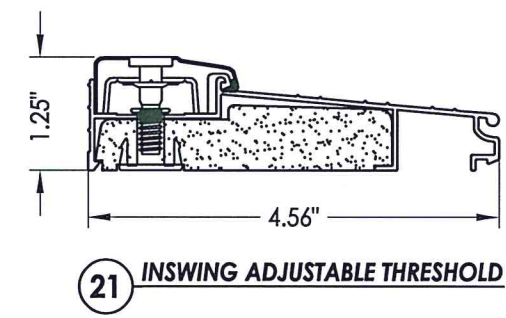
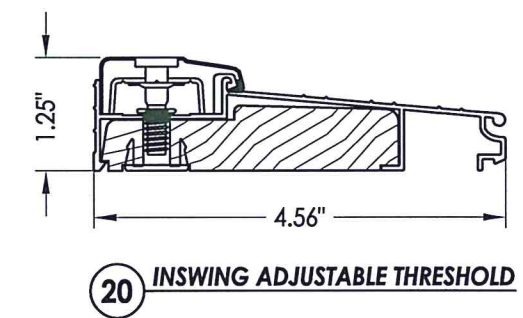
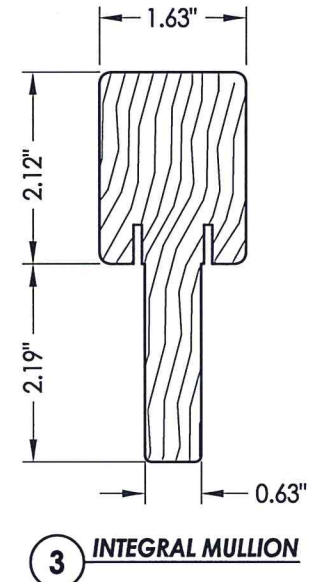
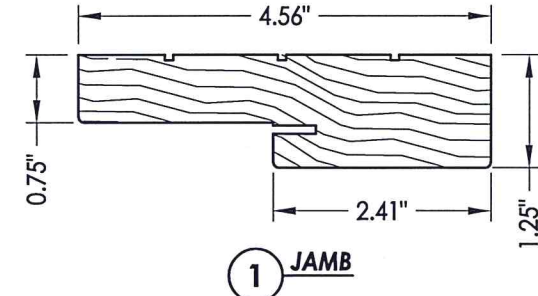

CONCRETE ANCHOR NOTES:

- Concrete anchor locations at the corners may be adjusted to maintain the min. edge distance to mortar joints.
- Concrete anchor locations noted as "MAX. ON CENTER" must be adjusted to maintain the min. edge distance to mortar joints, additional concrete anchors may be required to ensure the "MAX. ON CENTER" dimension are not exceeded.
- Concrete anchor table:

ANCHOR TYPE	ANCHOR SIZE	MIN. EMBEDMENT	MIN. CLEARANCE TO MASONRY EDGE	MIN. CLEARANCE TO ADJACENT ANCHOR
ITW BUILDDEX TAPCON®	3/16"	1-3/4"	3"	1-1/2"
	1/4"	1-3/4"	2"	4"
DeWALT ULTRACON®	1/4"	1-3/4"	1"	4"

WOOD SCREW INSTALLATION NOTES:

- Maintain a minimum 5/8" edge distance, 1" end distance, & 1" o.c. spacing of wood screws to prevent the splitting of wood.

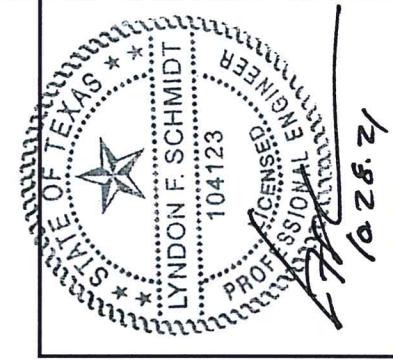

Documents Prepared By: Lyndon F. Schmidt, P.E.
TEXAS P.E. #104123

RW BUILDING CONSULTANTS, INC.
P.O. Box 230 Vairico FL. 33595
Phone No.: 813.659.9197

TEXAS BOARD OF PROFESSIONAL ENGINEERS
CERTIFICATE OF REGISTRATION # F-11852

PRODUCT: DOORSCAPES STEEL DOOR

PART OR ASSEMBLY: BILL OF MATERIALS & COMPONENTS

NO.	DATE	DESCRIPTION	BY
1	10/28/21	UPDATE TO 2018 IBC/IRC CODE	LFS

REVISIONS

DATE: 5/06/19

SCALE: N.T.S.

DWG. BY: MT

CHK. BY: LFS

DRAWING NO.: TX-4933

SHEET 10 of 10