

REVISIONS			
REV	DESCRIPTION	DATE	APPROVED
A	REVISED PER NEW CODE	12/20/2021	R.L.

NOTES:

1. THE PRODUCT SHOWN HEREIN IS DESIGNED AND MANUFACTURED TO COMPLY WITH REQUIREMENTS OF THE 2018 IBC AND 2018 IRC.
2. WOOD FRAMING AND MASONRY OPENING TO BE DESIGNED AND ANCHORED TO PROPERLY TRANSFER ALL LOADS TO STRUCTURE. FRAMING AND MASONRY OPENING IS THE RESPONSIBILITY OF THE ARCHITECT OR ENGINEER OF RECORD.
3. 1X BUCK OVER MASONRY/CONCRETE IS OPTIONAL.
4. WHERE SHIM OR BUCK THICKNESS IS LESS THAN 1-1/2" WINDOW UNITS MUST BE ANCHORED THROUGH THE FRAME IN ACCORDANCE WITH MANUFACTURER'S PUBLISHED INSTALLATION INSTRUCTIONS. ANCHORS SHALL BE SECURELY FASTENED DIRECTLY INTO MASONRY, CONCRETE OR OTHER STRUCTURAL SUBSTRATE MATERIAL.
5. WHERE WOOD BUCK THICKNESS IS 1-1/2" OR GREATER, BUCK SHALL BE SECURELY FASTENED TO MASONRY, CONCRETE OR OTHER STRUCTURAL SUBSTRATE. WINDOW UNITS MAY BE ANCHORED THROUGH FRAME TO SECURED WOOD BUCK IN ACCORDANCE WITH MANUFACTURER'S PUBLISHED INSTALLATION INSTRUCTIONS.
6. WHERE 1X BUCK IS NOT USED DISSIMILAR MATERIALS MUST BE SEPARATED WITH APPROVED COATING OR MEMBRANE. SELECTION OF COATING OR MEMBRANE IS THE RESPONSIBILITY OF THE ARCHITECT OR ENGINEER OF RECORD.
7. BUCKS SHALL EXTEND BEYOND WINDOW INTERIOR FACE SO THAT FULL FRAME SUPPORT IS PROVIDED.
8. SHIM AS REQUIRED AT EACH ANCHOR LOCATION WITH LOAD BEARING SHIM. SHIM WHERE SPACE OF 1/16" OR GREATER OCCURS. MAXIMUM ALLOWABLE SHIM STACK TO BE 1/4".
9. SHIMS SHALL BE LOCATED, APPLIED AND MADE FROM MATERIALS AND THICKNESS CAPABLE OF SUSTAINING APPLICABLE LOADS.
10. WIND LOAD DURATION FACTOR Cd=1.6 WAS USED FOR WOOD ANCHOR CALCULATIONS.
11. FRAME MATERIAL: CO-EXTRUDED PVC FOAM.
12. UNITS MUST BE GLAZED PER ASTM E1300, SEE SHEET 2 FOR GLASS DETAILS.
13. APPROVED IMPACT PROTECTIVE SYSTEM IS NOT REQUIRED FOR THIS PRODUCT IN WIND BORNE DEBRIS REGIONS.
14. FOR ANCHORING INTO WOOD FRAMING OR 2X BUCK USE #10 WOOD SCREWS WITH SUFFICIENT LENGTH TO ACHIEVE A 1 1/4" MINIMUM EMBEDMENT INTO SUBSTRATE. LOCATE ANCHORS AS SHOWN IN ELEVATIONS AND INSTALLATION DETAILS.

15. FOR ANCHORING INTO MASONRY/CONCRETE USE 3/16" TAPCONS WITH SUFFICIENT LENGTH TO ACHIEVE A 1 3/4" MINIMUM EMBEDMENT INTO SUBSTRATE WITH 2" MINIMUM EDGE DISTANCE. LOCATE ANCHORS AS SHOWN IN ELEVATIONS AND INSTALLATION DETAILS.
16. FOR ANCHORING INTO METAL STRUCTURE USE #10 SMS OR SELF DRILLING SCREWS WITH SUFFICIENT LENGTH TO ACHIEVE 3 THREADS MINIMUM BEYOND STRUCTURE INTERIOR WALL. LOCATE ANCHORS AS SHOWN IN ELEVATIONS AND INSTALLATION DETAILS.
17. ALL FASTENERS TO BE CORROSION RESISTANT.
18. INSTALLATION ANCHORS SHALL BE INSTALLED IN ACCORDANCE WITH ANCHOR MANUFACTURER'S INSTALLATION INSTRUCTIONS AND ANCHORS SHALL NOT BE USED IN SUBSTRATES WITH STRENGTHS LESS THAN THE MINIMUM STRENGTH SPECIFIED BELOW:
  - A. WOOD - MINIMUM SPECIFIC GRAVITY OF G=0.42
  - B. CONCRETE - MINIMUM COMPRESSIVE STRENGTH OF 3,192 PSI.
  - C. MASONRY - STRENGTH CONFORMANCE TO ASTM C-90, GRADE N, TYPE 1 (OR GREATER).
  - D. METAL STRUCTURE: STEEL 18GA, 33KSI OR ALUMINUM 6063-T5 1/8" THICK MINIMUM
19. APPROVED CONFIGURATIONS: X, X/O, O/X, OX, XO, OX/O, XO/O, XX, XX/O, O/XX, OXX, XXO, OXX/O AND O/XXO, SEE SHEET 3.
20. SIDELITES ARE ASSEMBLED TO FRAME WITH #10 X 3" WOOD SCREWS LOCATED 4" FROM EACH END AND 19 1/8" MAX O.C. THEREAFTER AT JAMBS AND 4" FROM EACH END AND ONE AT MIDSPAN AT HEAD AND SILL.

TABLE OF CONTENTS	
SHEET NO.	DESCRIPTION
1	NOTES
2	ELEVATION AND GLAZING DETAIL
3	APPROVED CONFIGURATIONS
4 - 5	ANCHORING LAYOUTS
6 - 12	INSTALLATION DETAILS
13 - 14	COMPONENTS

<b>NAN YA PLASTICS CORP. USA</b> 8989 NORTH LOOP EAST HOUSTON, TX 77029		
<b>SLPS PATIO DOOR LITE 6'11" OUT-SWING          LARGE MISSILE IMPACT          NOTES</b>		
DRAWN: A.R.	DWG NO. 08-03342	REV A
SCALE NTS	DATE 10/29/18	SHEET 1 OF 14
L. ROBERTO LOMAS P.E. 1432 WOODFORD RD LEWISVILLE, NC 27023 434-688-0609 rllomas@rlomaspe.com		

SIGNED: 12/20/2021



Luis R. Lomas P.E.  
 TX No.: 101889  
 Firm No: F-23130

REVISIONS			
REV	DESCRIPTION	DATE	APPROVED
A	REVISED PER NEW CODE	12/20/2021	R.L.

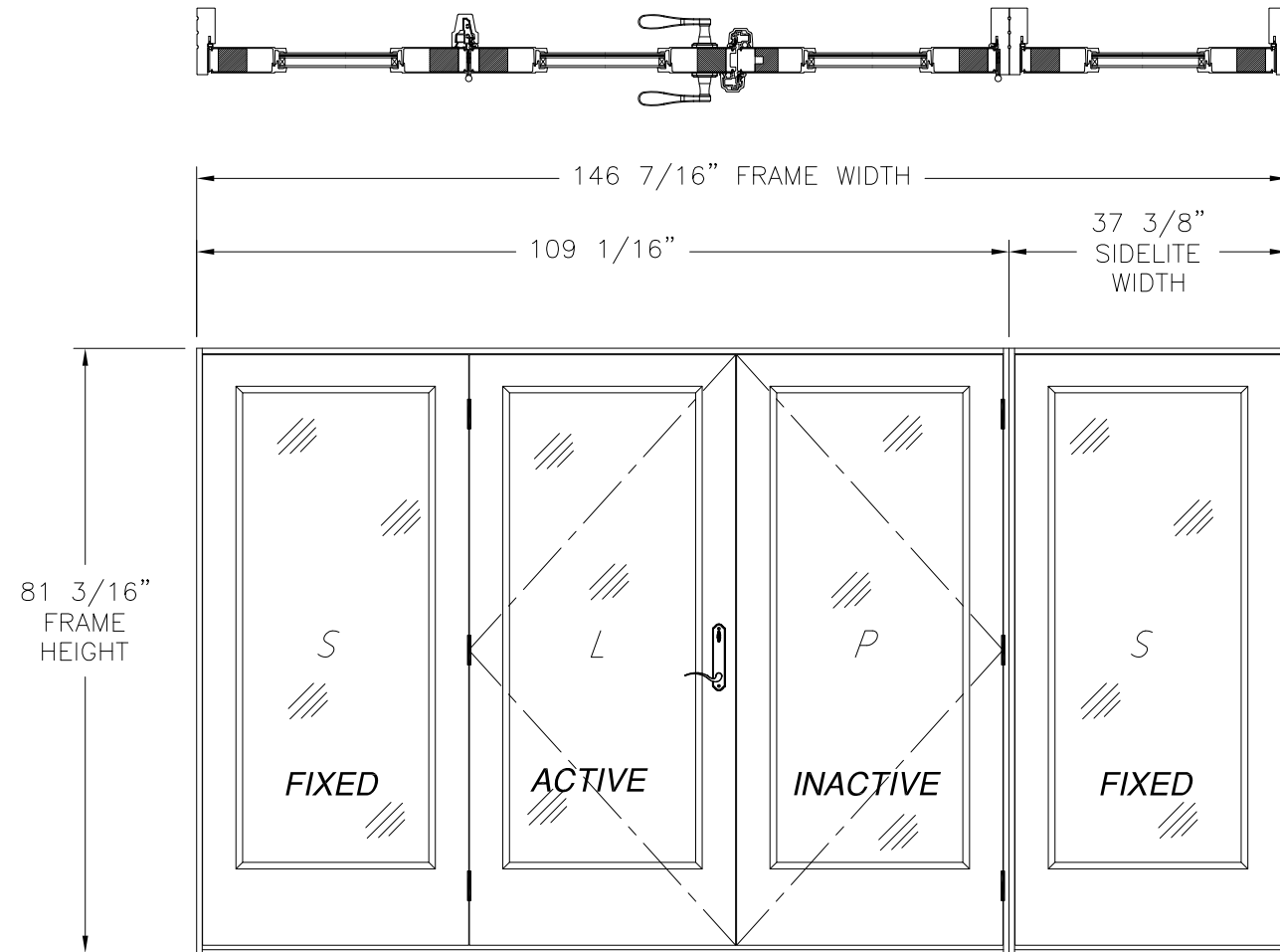

- NOTES:  
1. PANEL SIZE: 35 3/4" X 79 1/4"  
2. D.L.O.: 25" X 63"

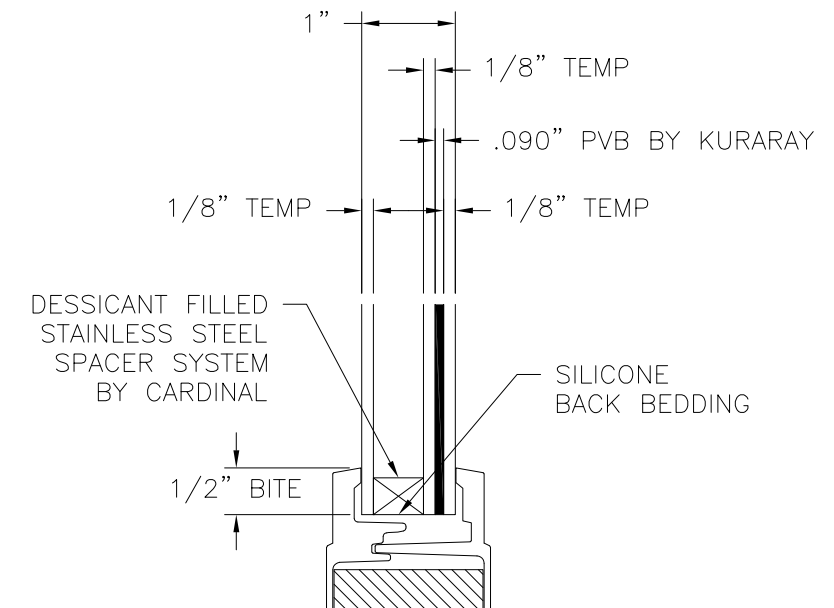

SLPS PATIO DOOR LITE 6'11" OUT-SWING  
EXTERIOR VIEW

GLAZING DETAIL

WITH STANDARD SILL

DESIGN PRESSURE RATING	IMPACT RATING
+50.0/-60.0PSF	LARGE AND SMALL MISSILE IMPACT

MISSILE LEVEL D, WIND ZONE 4

WITH 1/2" SILL RISER

DESIGN PRESSURE RATING	IMPACT RATING
±60.0PSF	LARGE AND SMALL MISSILE IMPACT

MISSILE LEVEL D, WIND ZONE 4

HARDWARE SCHEDULE

A.	HANDLE SETS AT ACTIVE PANEL
B.	STAINLESS STEEL FLUSH BOLT BAR WITH KEEPER AT PASSIVE PANEL
C.	FLUSH BOLT MECHANISM (DIE CAST, STEEL, POM) AT PASSIVE PANEL
D.	STAINLESS STEEL MULTI-POINT LOCK WITH KEEPERS AT 11 9/16", 40 9/16" & 69 5/8" FROM FRAME HEAD
E.	T ASTRAGAL AT ACTIVE AND PASSIVE PANELS
F.	(3) 4X4 DOOR HINGE, 7 5/8", 37 7/8" AND 68 1/8" FROM FRAME HEAD AT STILE OF ACTIVE AND PASSIVE PANEL
G.	ALUMINUM REINFORCEMENT (A) AT ASTRAGAL
H.	ALUMINUM MULLION REINFORCEMENT (B) AT INTEGRAL MULLION

SIGNED: 12/20/2021

NAN YA PLASTICS CORP. USA  
8989 NORTH LOOP EAST  
HOUSTON, TX 77029

SLPS PATIO DOOR LITE 6'11" OUT-SWING  
LARGE MISSILE IMPACT  
ELEVATION AND GLAZING DETAIL

DRAWN: A.R.	DWG NO. 08-03342	REV A
SCALE NTS	DATE 10/29/18	SHEET 2 OF 14

L. ROBERTO LOMAS P.E.  
1432 WOODFORD RD LEWISVILLE, NC 27023  
434-688-0609 rllomas@lrlomaspe.com



Luis R. Lomas P.E.  
TX No.: 101889  
Firm No: F-23130

REVISIONS			
REV	DESCRIPTION	DATE	APPROVED
A	REVISED PER NEW CODE	12/20/2021	R.L.

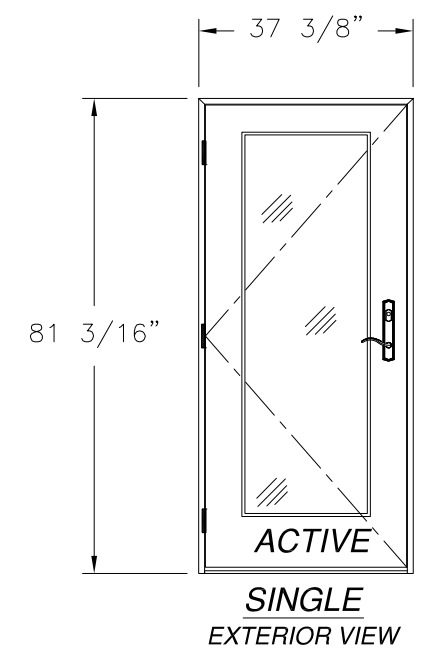
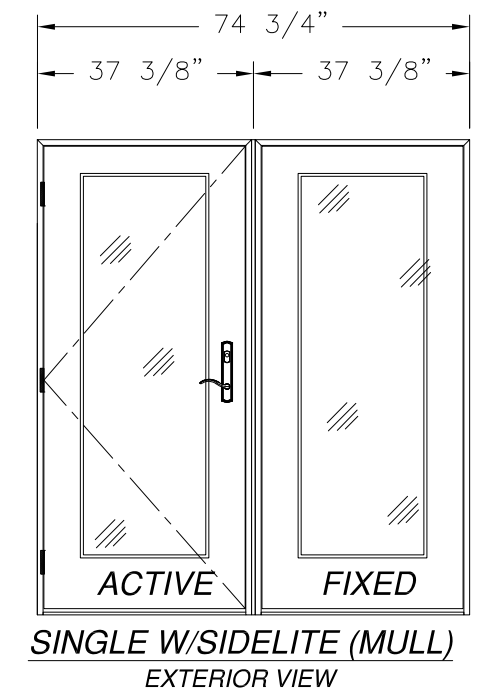
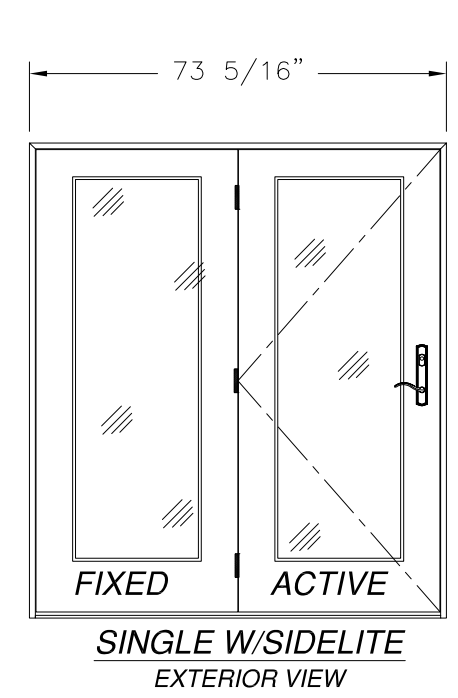
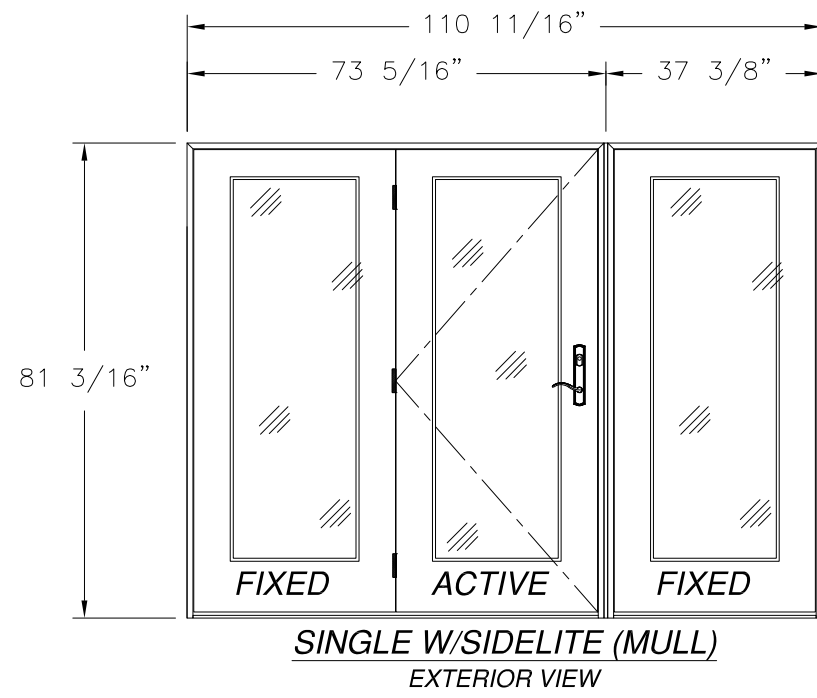
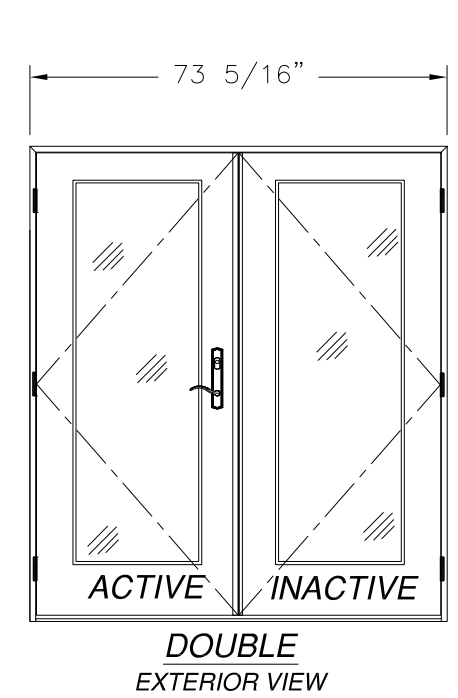
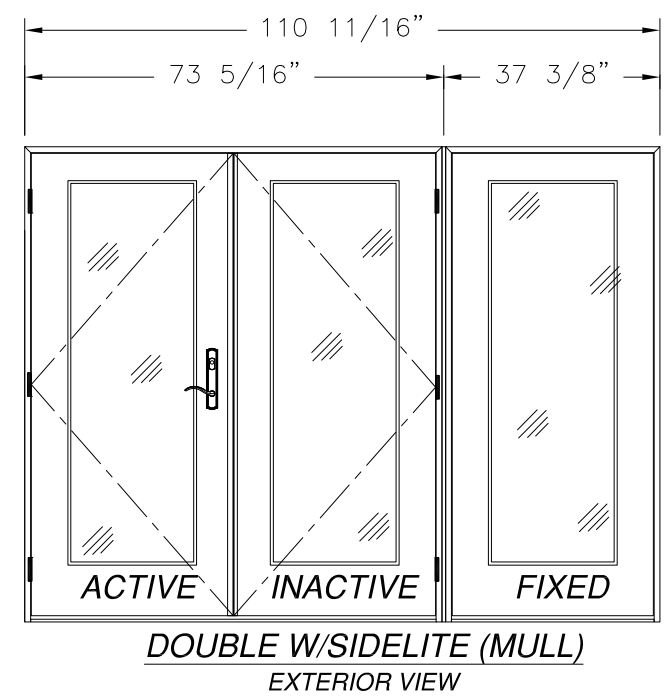
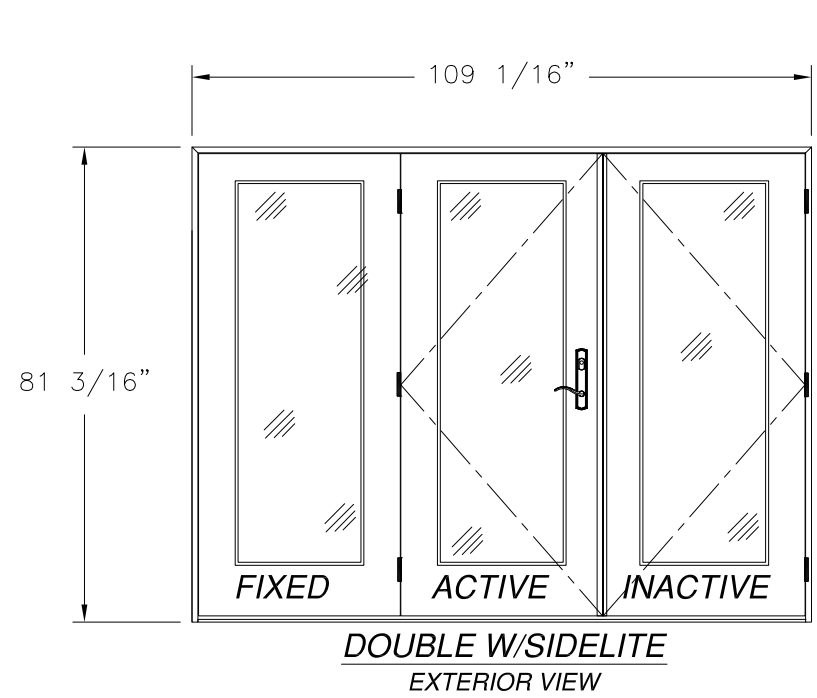

NOTE:  
ALL APPROVED CONFIGURATIONS ARE SHOWN AS LEFT  
HAND ACTIVE, RIGHT HAND ACTIVE IS ALSO APPROVED.

SIGNED: 12/20/2021

NAN YA PLASTICS CORP. USA  
8989 NORTH LOOP EAST  
HOUSTON, TX 77029

SLPS PATIO DOOR LITE 6'11" OUT-SWING  
LARGE MISSILE IMPACT  
APPROVED CONFIGURATIONS

DRAWN: A.R.	DWG NO. 08-03342	REV A
SCALE NTS	DATE 10/29/18	SHEET 3 OF 14

L. ROBERTO LOMAS P.E.  
1432 WOODFORD RD LEWISVILLE, NC 27023  
434-688-0609 rllomas@rlomaspe.com



Luis R. Lomas P.E.  
TX No.: 101889  
Firm No: F-23130

REVISIONS			
REV	DESCRIPTION	DATE	APPROVED
A	REVISED PER NEW CODE	12/20/2021	R.L.

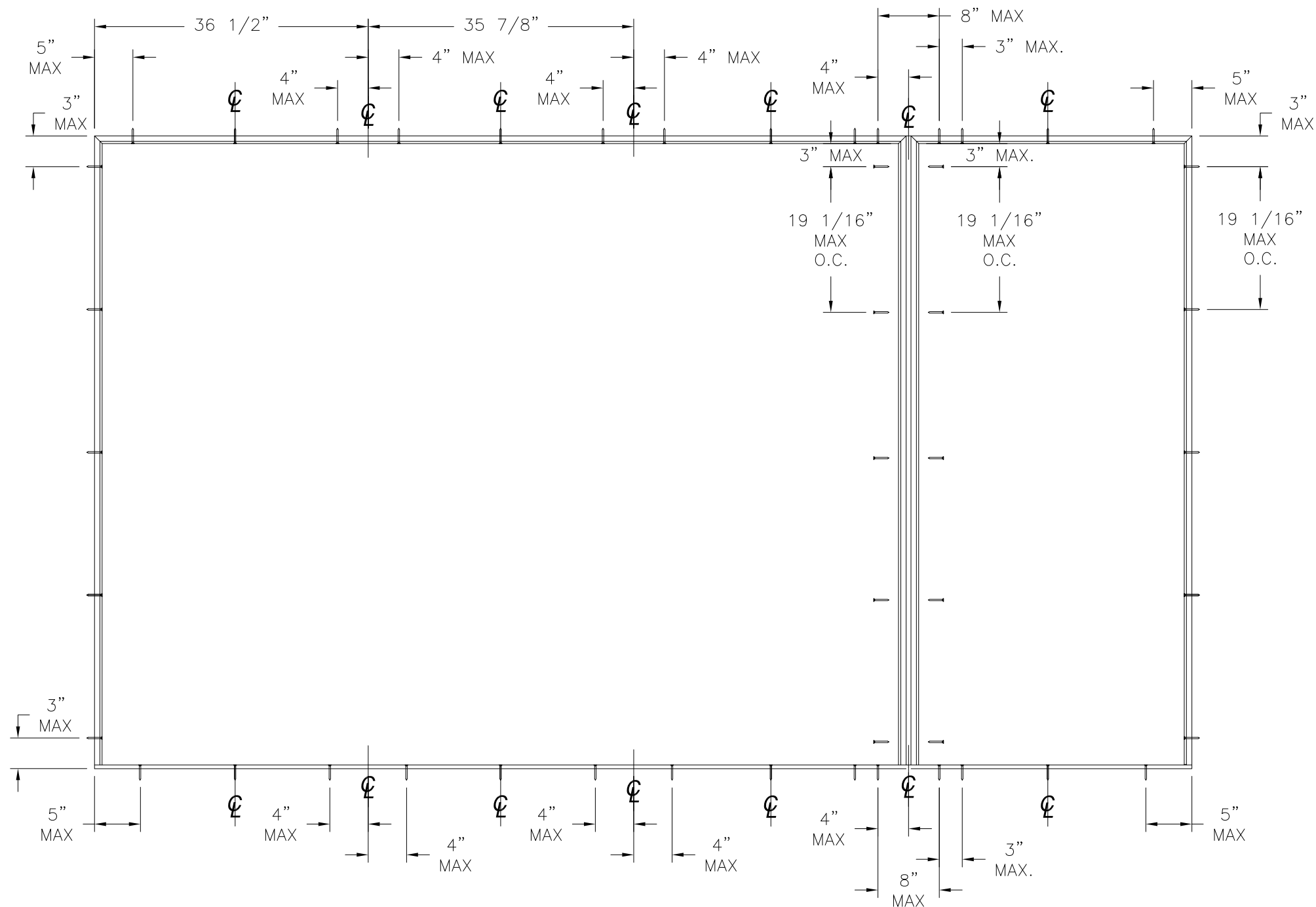

ANCHORING LAYOUT

SIGNED: 12/20/2021

<p>NAN YA PLASTICS CORP. USA          8989 NORTH LOOP EAST          HOUSTON, TX 77029</p>		
<p>SLPS PATIO DOOR LITE 6'11" OUT-SWING          LARGE MISSILE IMPACT          ANCHORING LAYOUTS</p>		
<p>DRAWN: A.R.</p>	<p>DWG NO. 08-03342</p>	<p>REV A</p>
<p>SCALE NTS</p>	<p>DATE 10/29/18</p>	<p>SHEET 4 OF 14</p>
<p>L. ROBERTO LOMAS P.E.          1432 WOODFORD RD LEWISVILLE, NC 27023          434-688-0609 rllomas@rlomaspe.com</p>		



Luis R. Lomas P.E.  
 TX No.: 101889  
 Firm No: F-23130

REVISIONS			
REV	DESCRIPTION	DATE	APPROVED
A	REVISED PER NEW CODE	12/20/2021	R.L.

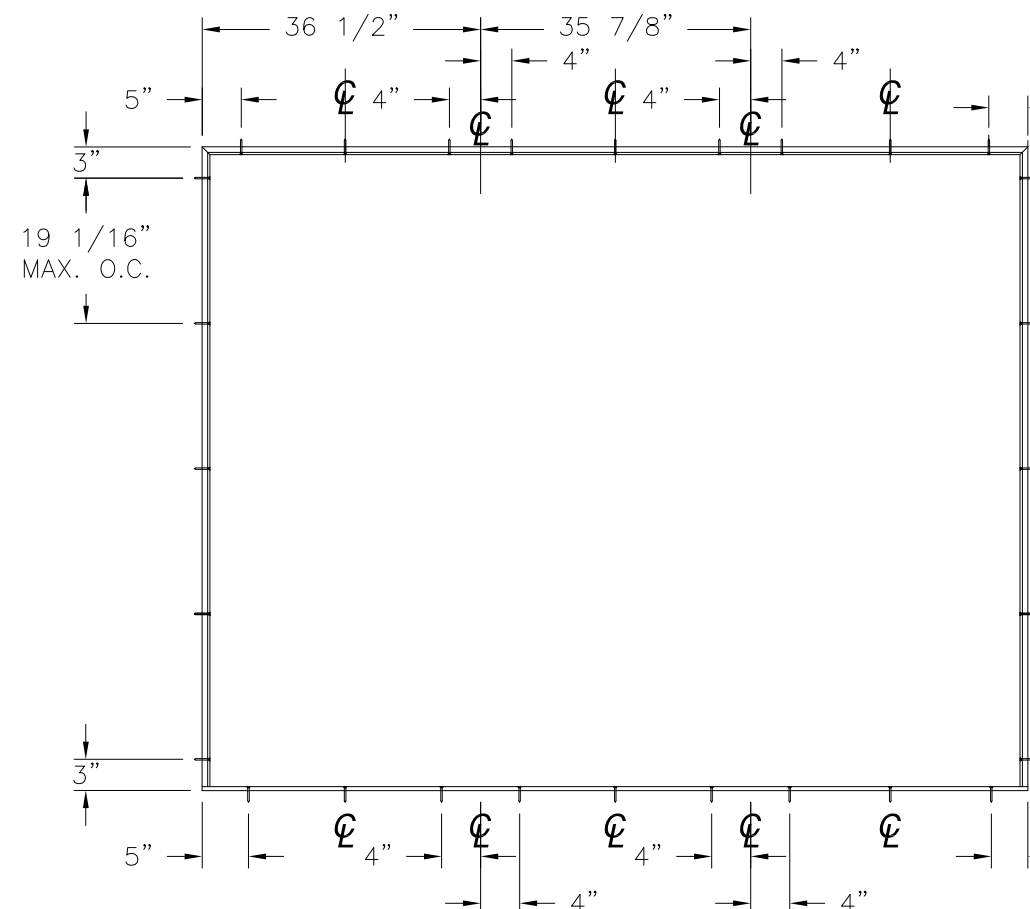

**ANCHORING LAYOUT FOR OXO, XXO AND OXX**

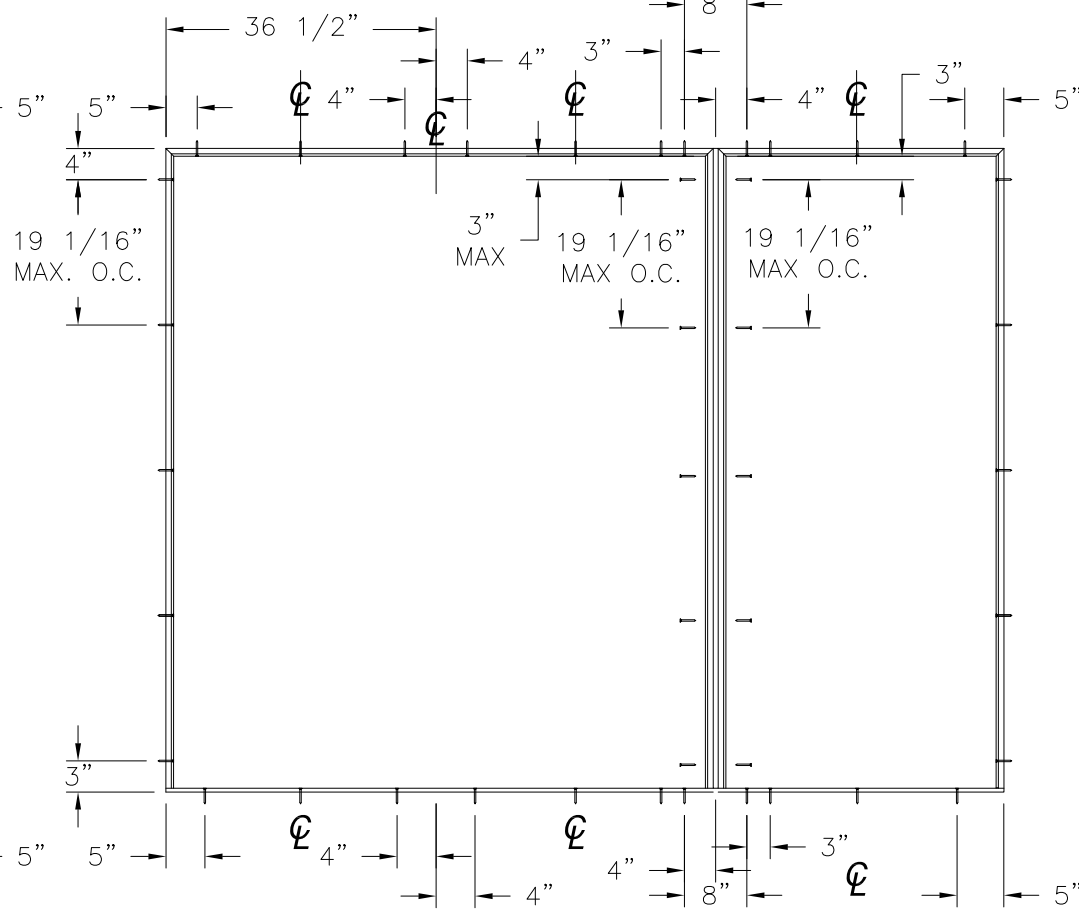

**ANCHORING LAYOUT FOR OXO, XXO AND OXX (MULL)**

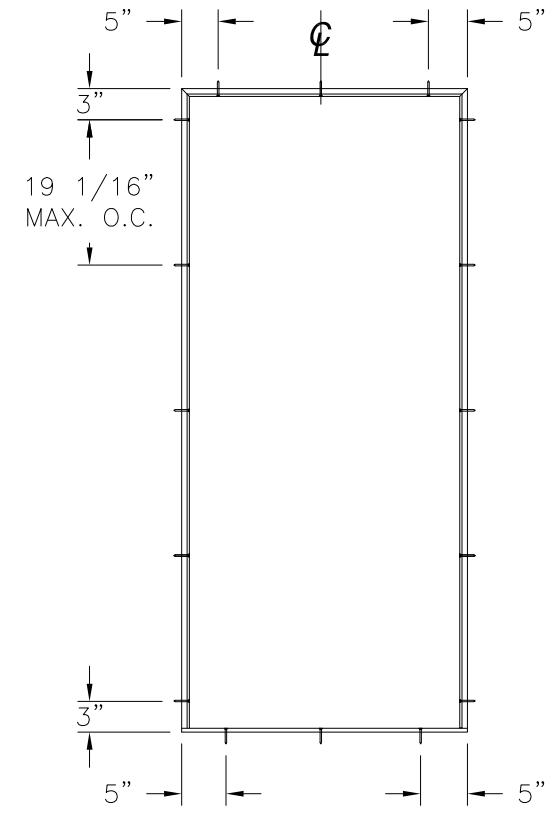

**ANCHORING LAYOUT FOR X**

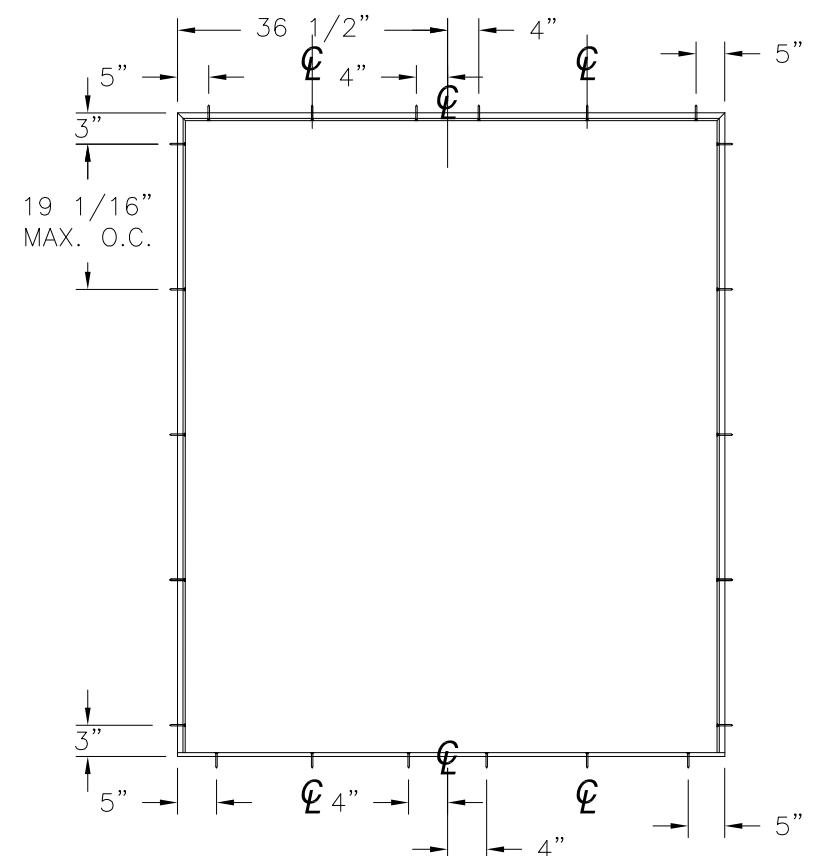

**ANCHORING LAYOUT FOR XX, OX AND XO**

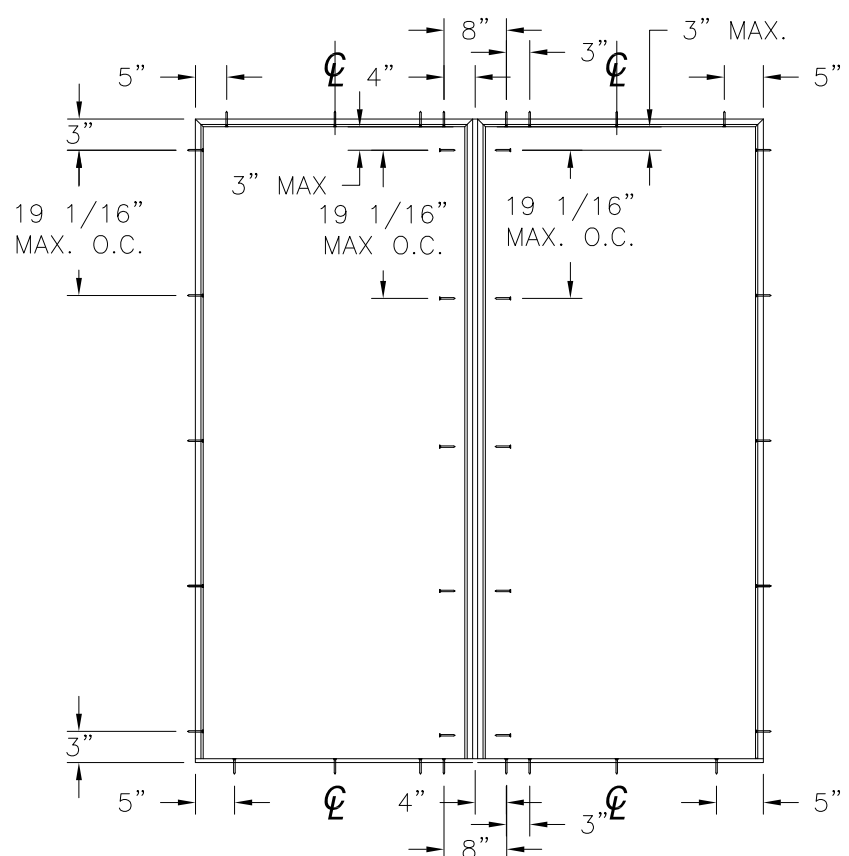

**ANCHORING LAYOUT FOR OX AND XO (MULL)**

NAN YA PLASTICS CORP. USA  
 8989 NORTH LOOP EAST  
 HOUSTON, TX 77029

SLPS PATIO DOOR LITE 6'11" OUT-SWING  
 LARGE MISSILE IMPACT  
 ANCHORING LAYOUTS

DRAWN: A.R.	DWG NO. 08-03342	REV A
SCALE NTS	DATE 10/29/18	SHEET 5 OF 14

L. ROBERTO LOMAS P.E.  
 1432 WOODFORD RD LEWISVILLE, NC 27023  
 434-688-0609 rllomas@rlomaspe.com

SIGNED: 12/20/2021



Luis R. Lomas P.E.  
 TX No.: 101889  
 Firm No: F-23130

REVISIONS			
REV	DESCRIPTION	DATE	APPROVED
A	REVISED PER NEW CODE	12/20/2021	R.L.

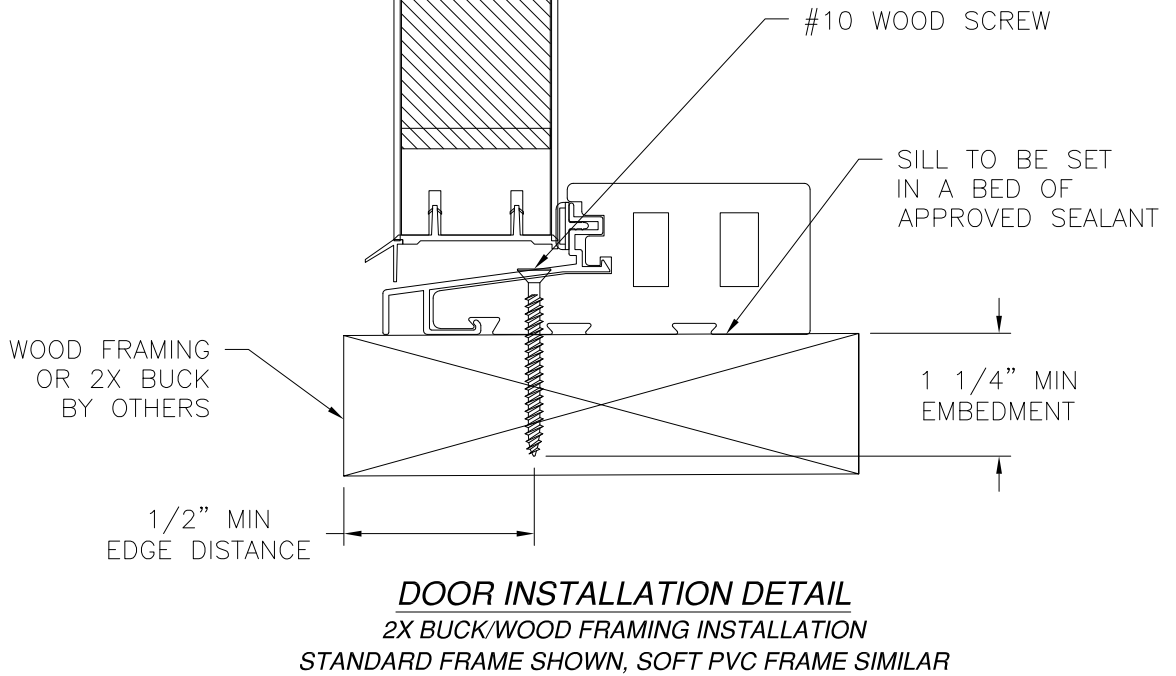
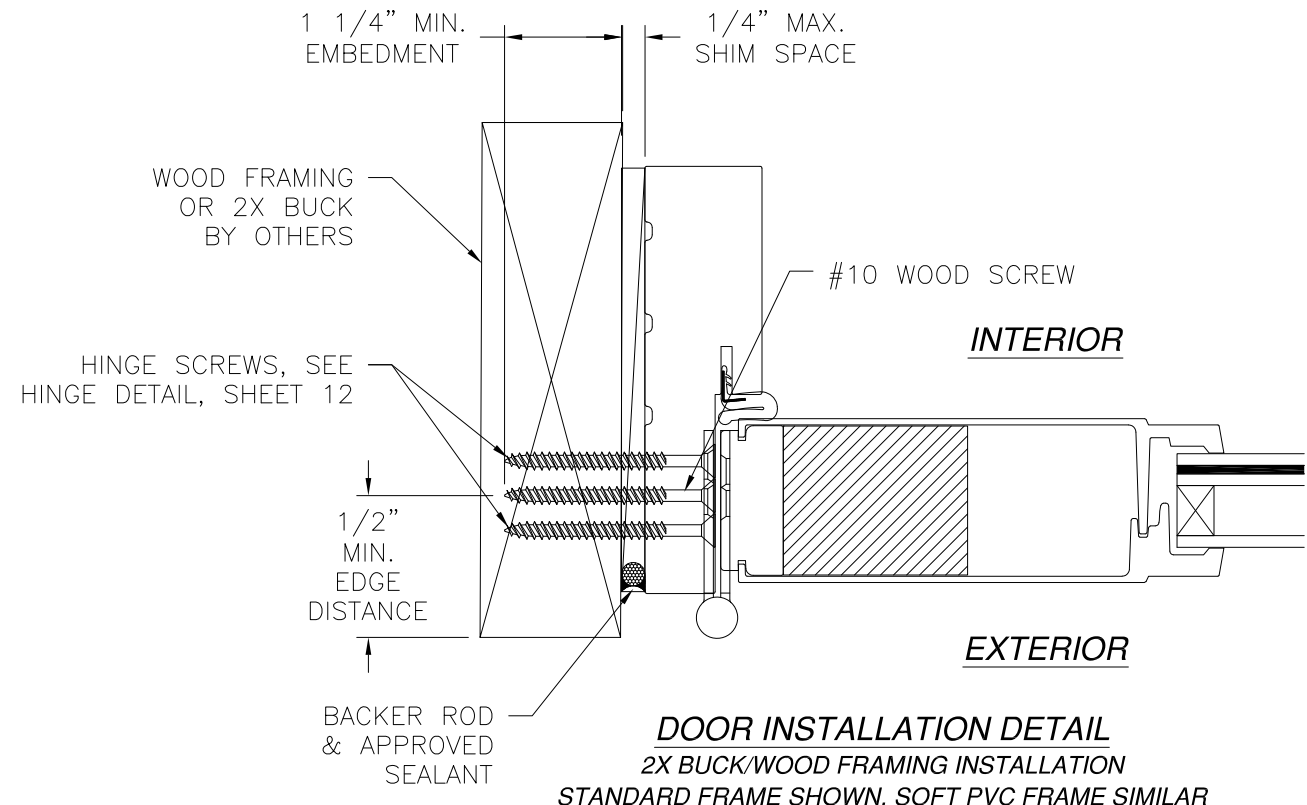
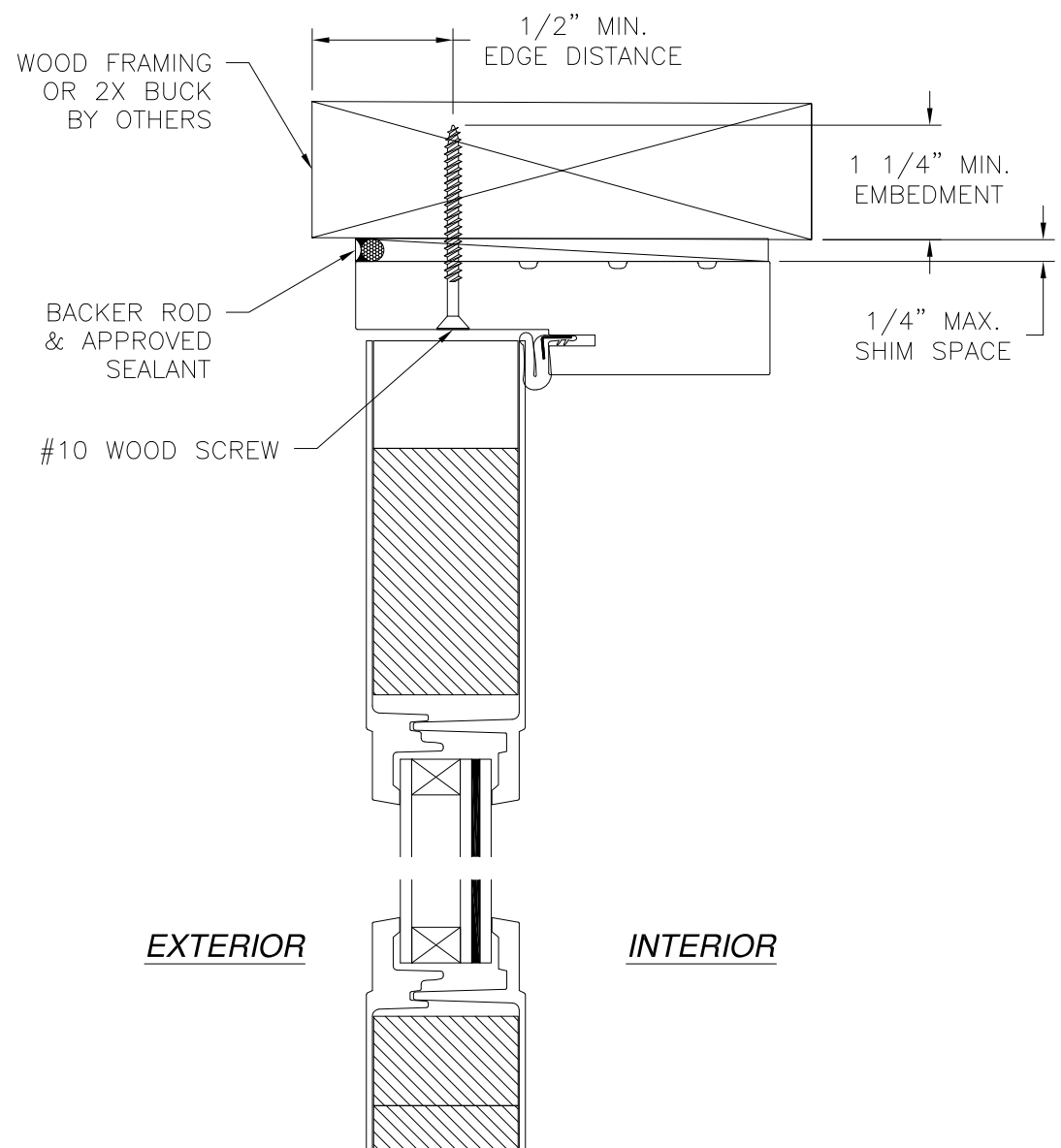

- NOTES:**
1. INTERIOR AND EXTERIOR FINISHES, BY OTHERS, NOT SHOWN FOR CLARITY.
  2. PERIMETER AND JOINT SEALANT BY OTHERS TO BE DESIGNED IN ACCORDANCE WITH ASTM E2112

SIGNED: 12/20/2021

NAN YA PLASTICS CORP. USA  
8989 NORTH LOOP EAST  
HOUSTON, TX 77029

SLPS PATIO DOOR LITE 6'11" OUT-SWING  
LARGE MISSILE IMPACT  
DOOR INSTALLATION DETAILS

DRAWN: A.R.	DWG NO. 08-03342	REV A
SCALE NTS	DATE 10/29/18	SHEET 6 OF 14

L. ROBERTO LOMAS P.E.  
1432 WOODFORD RD LEWISVILLE, NC 27023  
434-688-0609 rllomas@rlomaspe.com



Luis R. Lomas P.E.  
TX No.: 101889  
Firm No: F-23130

REVISIONS			
REV	DESCRIPTION	DATE	APPROVED
A	REVISED PER NEW CODE	12/20/2021	R.L.

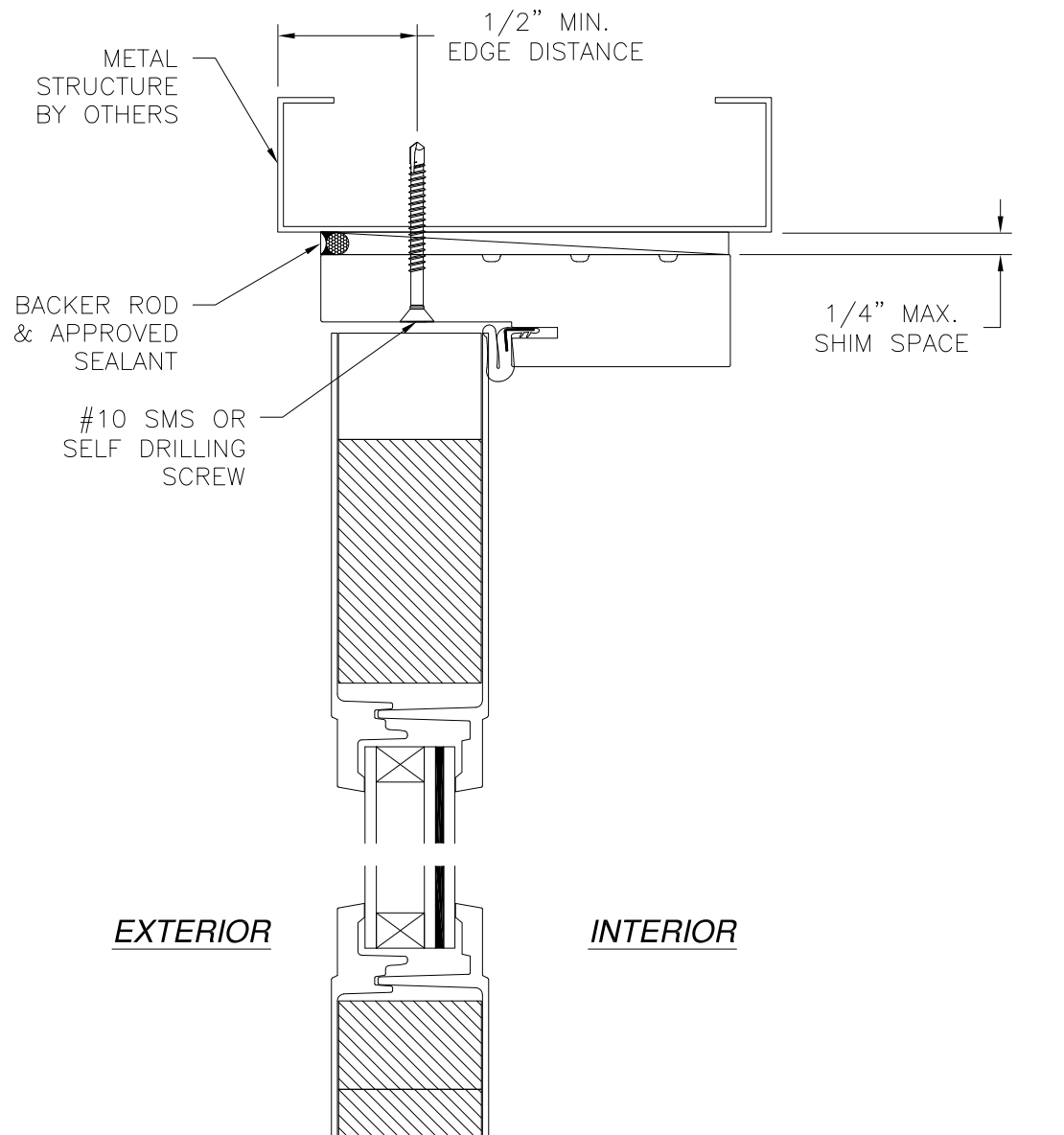

*EXTERIOR*                      *INTERIOR*

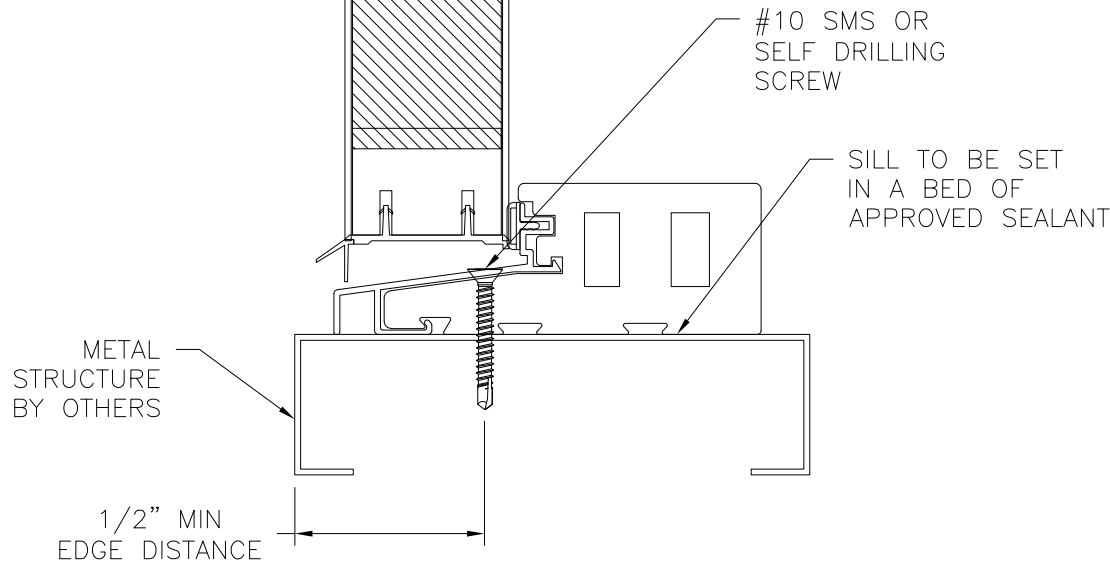

**DOOR INSTALLATION DETAIL**  
METAL STRUCTURE INSTALLATION  
STANDARD FRAME SHOWN, SOFT PVC FRAME SIMILAR

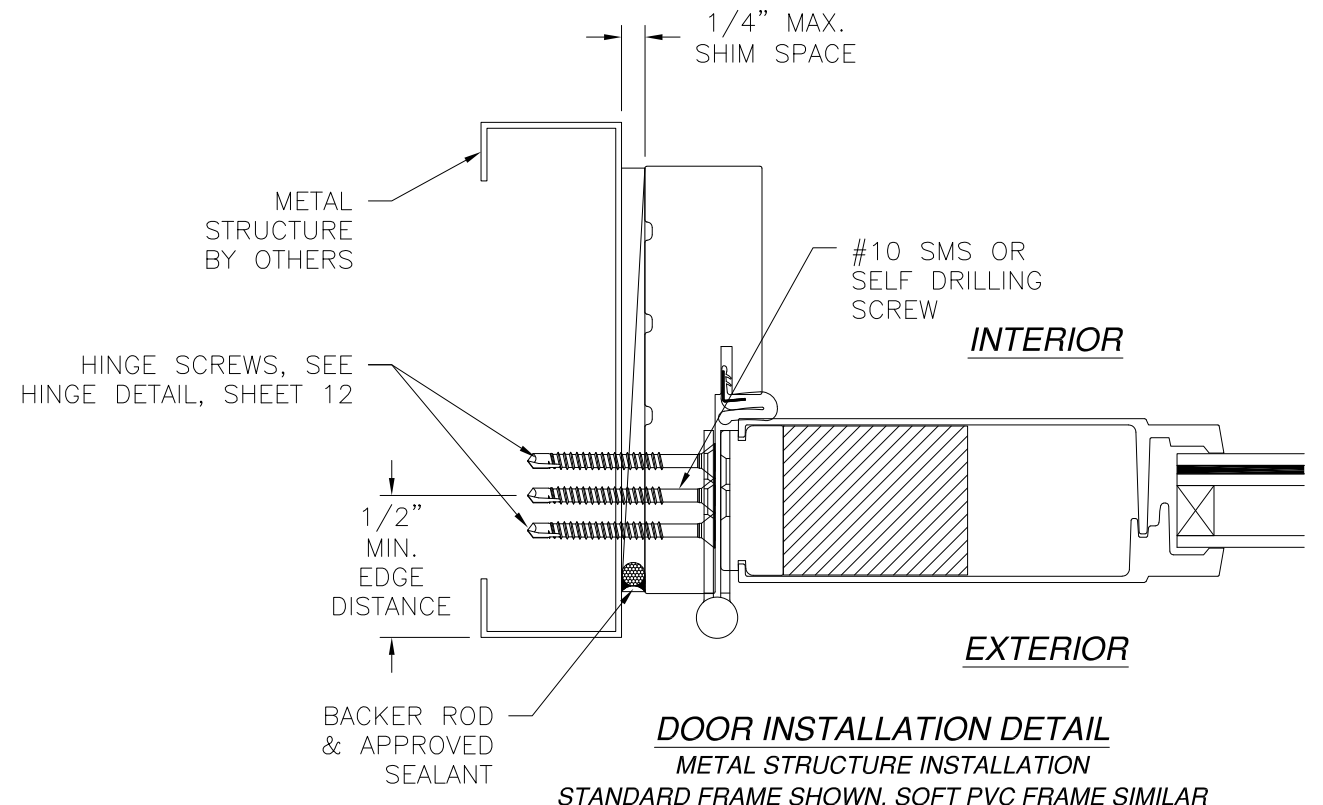

**DOOR INSTALLATION DETAIL**  
METAL STRUCTURE INSTALLATION  
STANDARD FRAME SHOWN, SOFT PVC FRAME SIMILAR

- NOTES:**
1. INTERIOR AND EXTERIOR FINISHES, BY OTHERS, NOT SHOWN FOR CLARITY.
  2. PERIMETER AND JOINT SEALANT BY OTHERS TO BE DESIGNED IN ACCORDANCE WITH ASTM E2112

SIGNED: 12/20/2021

NAN YA PLASTICS CORP. USA  
8989 NORTH LOOP EAST  
HOUSTON, TX 77029

SLPS PATIO DOOR LITE 6'11" OUT-SWING  
LARGE MISSILE IMPACT  
DOOR INSTALLATION DETAILS

DRAWN: A.R.	DWG NO. 08-03342	REV A
SCALE NTS	DATE 10/29/18	SHEET 7 OF 14

L. ROBERTO LOMAS P.E.  
1432 WOODFORD RD LEWISVILLE, NC 27023  
434-688-0609 rllomas@rlomaspe.com



Luis R. Lomas P.E.  
TX No.: 101889  
Firm No: F-23130

REVISIONS			
REV	DESCRIPTION	DATE	APPROVED
A	REVISED PER NEW CODE	12/20/2021	R.L.

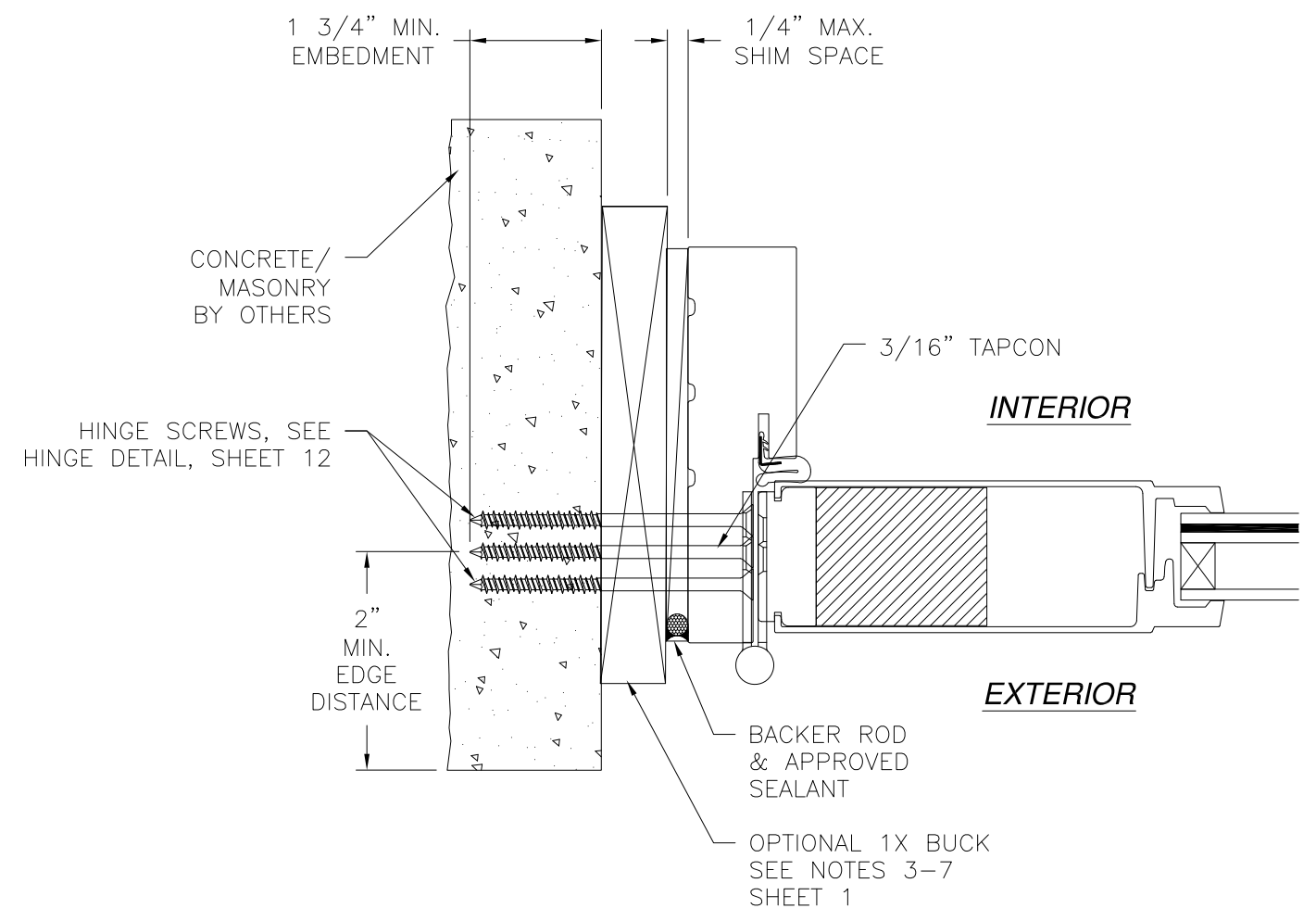
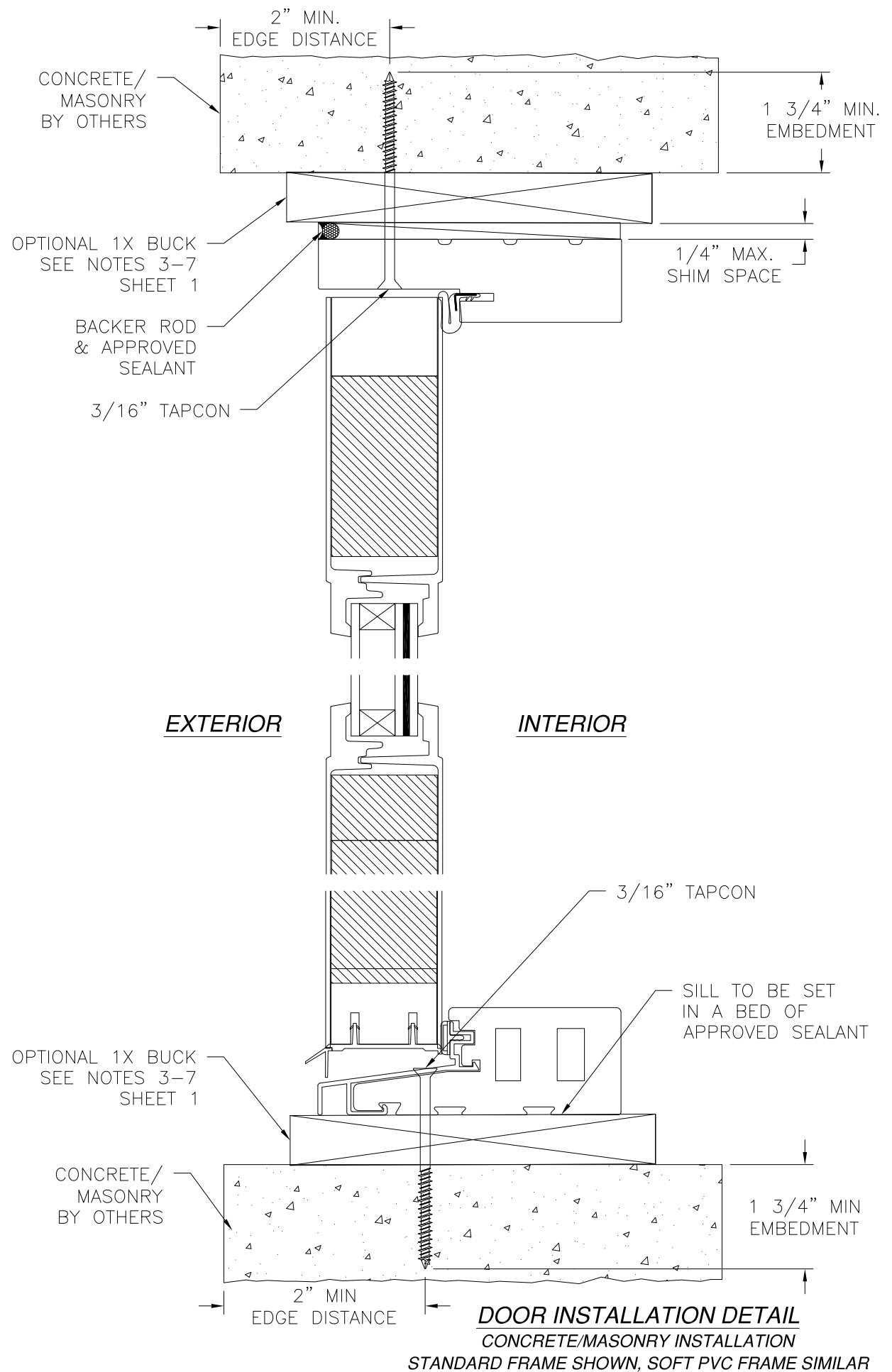

**DOOR INSTALLATION DETAIL**  
**CONCRETE/MASONRY INSTALLATION**  
 STANDARD FRAME SHOWN, SOFT PVC FRAME SIMILAR

- NOTES:**
1. INTERIOR AND EXTERIOR FINISHES, BY OTHERS, NOT SHOWN FOR CLARITY.
  2. PERIMETER AND JOINT SEALANT BY OTHERS TO BE DESIGNED IN ACCORDANCE WITH ASTM E2112

SIGNED: 12/20/2021

NAN YA PLASTICS CORP. USA  
 8989 NORTH LOOP EAST  
 HOUSTON, TX 77029

SLPS PATIO DOOR LITE 6'11" OUT-SWING  
 LARGE MISSILE IMPACT  
 DOOR INSTALLATION DETAILS

DRAWN: A.R.	DWG NO. 08-03342	REV A
SCALE NTS	DATE 10/29/18	SHEET 8 OF 14

L. ROBERTO LOMAS P.E.  
 1432 WOODFORD RD LEWISVILLE, NC 27023  
 434-688-0609 rllomas@rlomaspe.com



Luis R. Lomas P.E.  
 TX No.: 101889  
 Firm No: F-23130



REVISIONS			
REV	DESCRIPTION	DATE	APPROVED
A	REVISED PER NEW CODE	12/20/2021	R.L.

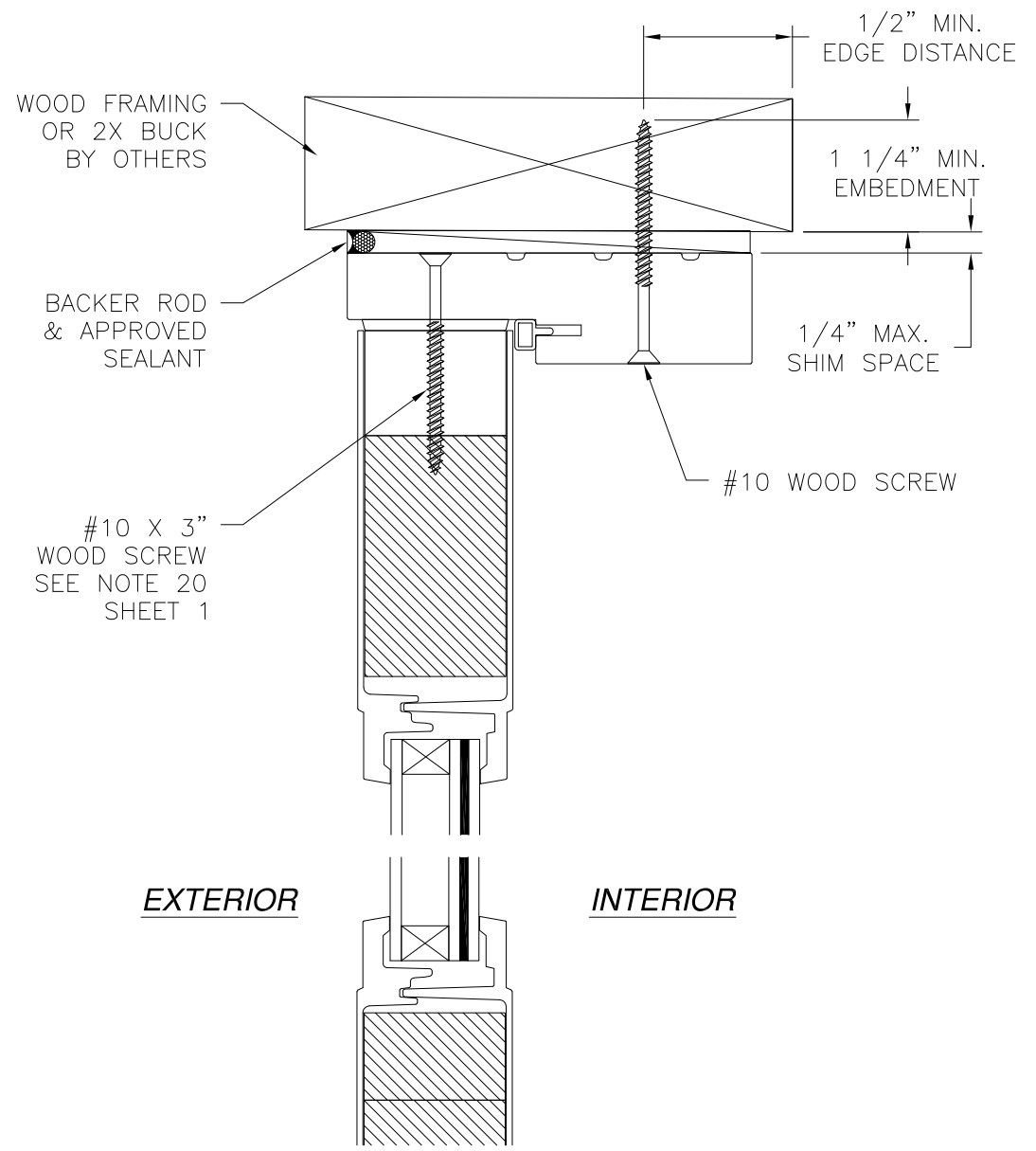

**EXTERIOR**                      **INTERIOR**

**SIDELITE INSTALLATION DETAIL**  
 2X BUCK/WOOD FRAMING INSTALLATION  
 STANDARD FRAME SHOWN, SOFT PVC FRAME SIMILAR

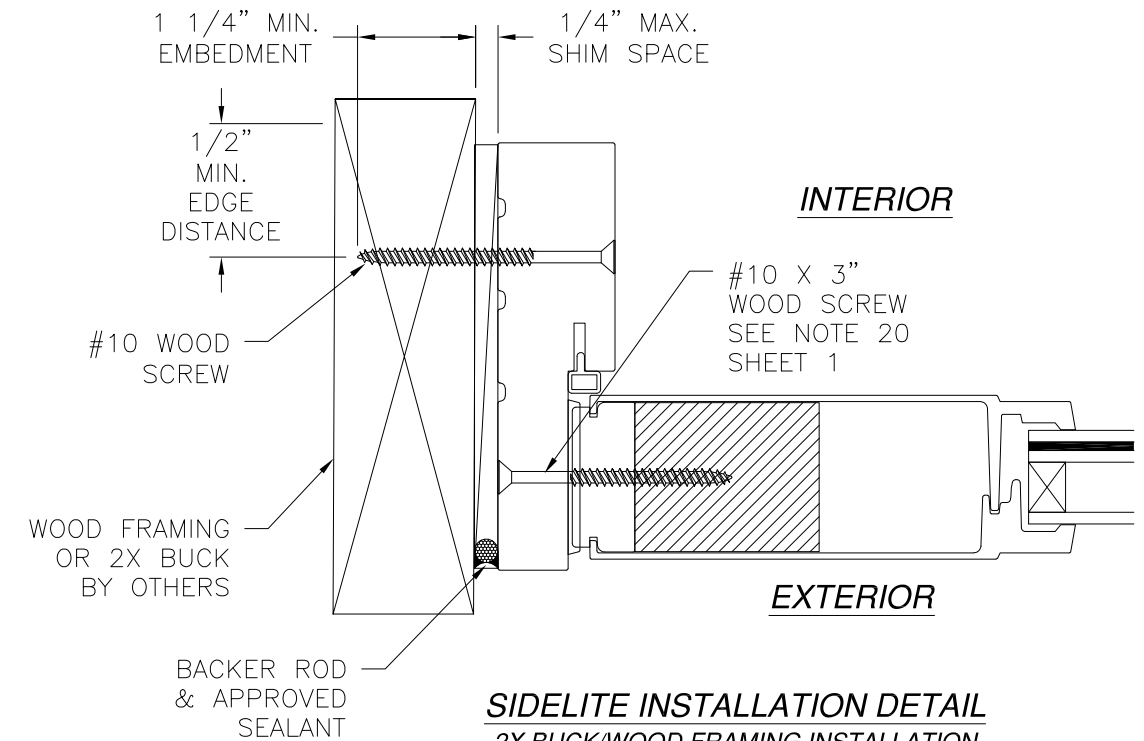

**INTERIOR**

**EXTERIOR**

**SIDELITE INSTALLATION DETAIL**  
 2X BUCK/WOOD FRAMING INSTALLATION  
 STANDARD FRAME SHOWN, SOFT PVC FRAME SIMILAR

- NOTES:**
1. INTERIOR AND EXTERIOR FINISHES, BY OTHERS, NOT SHOWN FOR CLARITY.
  2. PERIMETER AND JOINT SEALANT BY OTHERS TO BE DESIGNED IN ACCORDANCE WITH ASTM E2112

SIGNED: 12/20/2021

NAN YA PLASTICS CORP. USA 8989 NORTH LOOP EAST HOUSTON, TX 77029		
SLPS PATIO DOOR LITE 6'11" OUT-SWING LARGE MISSILE IMPACT SIDELITE INSTALLATION DETAILS		
DRAWN: A.R.	DWG NO. 08-03342	REV A
SCALE NTS	DATE 10/29/18	SHEET 9 OF 14
L. ROBERTO LOMAS P.E. 1432 WOODFORD RD LEWISVILLE, NC 27023 434-688-0609 rllomas@rlomaspe.com		



Luis R. Lomas P.E.  
 TX No.: 101889  
 Firm No: F-23130

REVISIONS			
REV	DESCRIPTION	DATE	APPROVED
A	REVISED PER NEW CODE	12/20/2021	R.L.

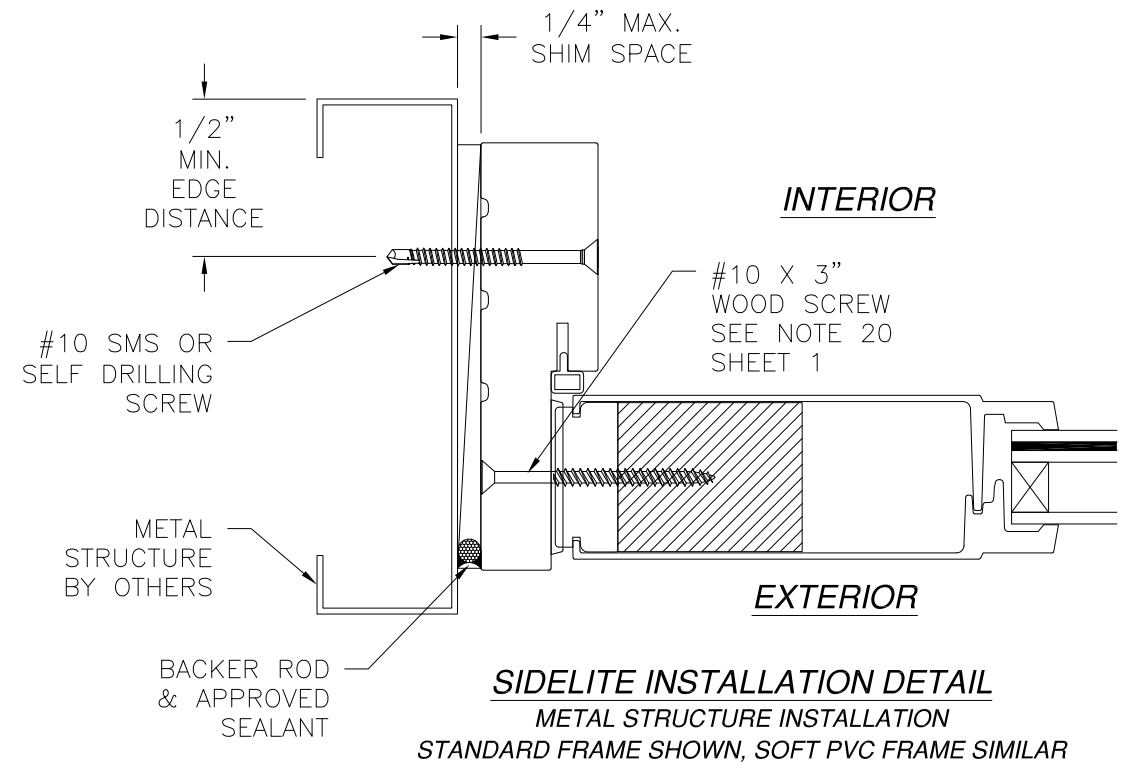
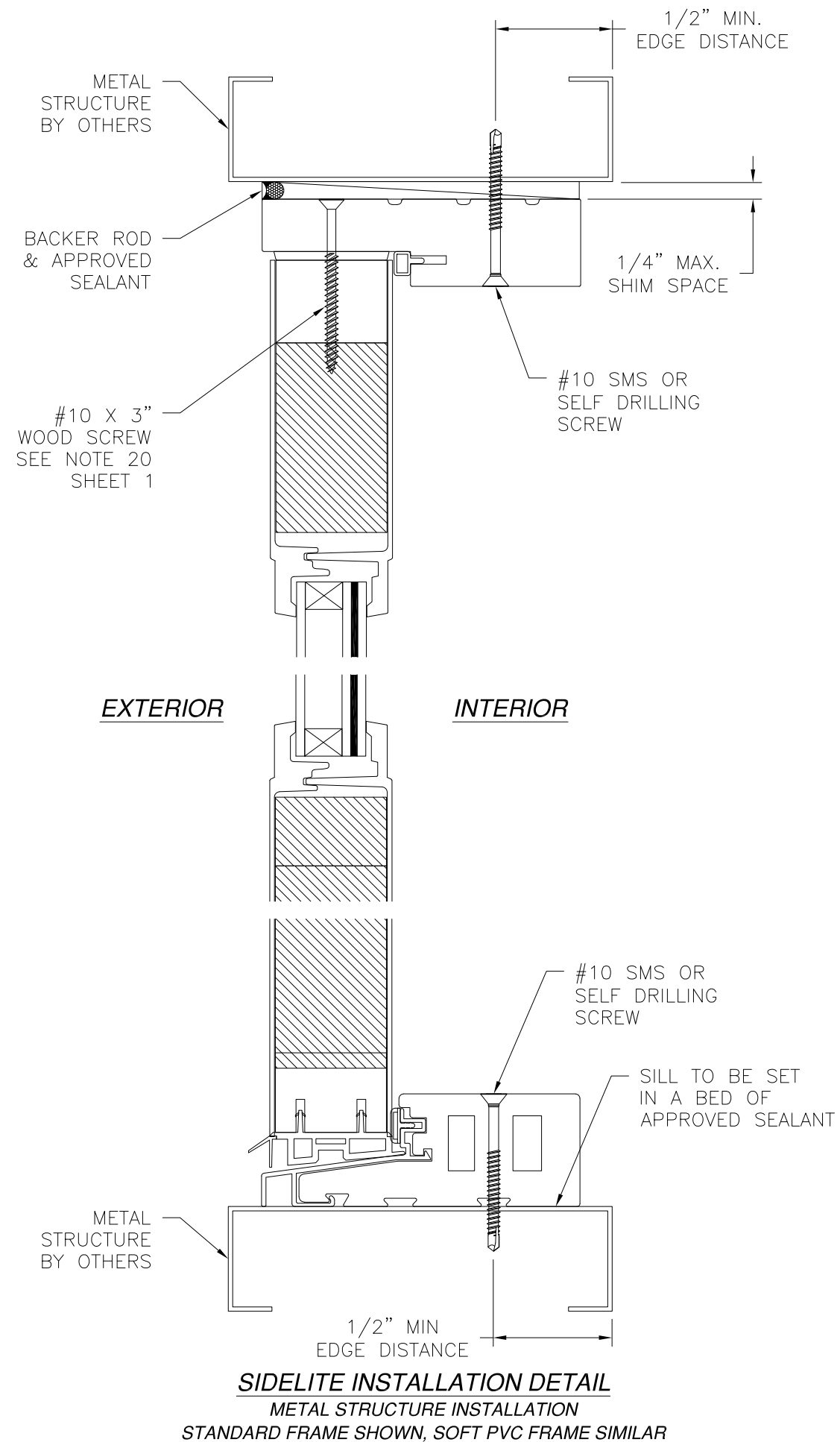

- NOTES:**
1. INTERIOR AND EXTERIOR FINISHES, BY OTHERS, NOT SHOWN FOR CLARITY.
  2. PERIMETER AND JOINT SEALANT BY OTHERS TO BE DESIGNED IN ACCORDANCE WITH ASTM E2112

SIGNED: 12/20/2021

NAN YA PLASTICS CORP. USA  
8989 NORTH LOOP EAST  
HOUSTON, TX 77029

SLPS PATIO DOOR LITE 6'11" OUT-SWING  
LARGE MISSILE IMPACT  
SIDELITE INSTALLATION DETAILS

DRAWN: A.R.	DWG NO. 08-03342	REV A
SCALE NTS	DATE 10/29/18	SHEET 10 OF 14

L. ROBERTO LOMAS P.E.  
1432 WOODFORD RD LEWISVILLE, NC 27023  
434-688-0609 rllomas@rlomaspe.com



Luis R. Lomas P.E.  
TX No.: 101889  
Firm No: F-23130

REVISIONS			
REV	DESCRIPTION	DATE	APPROVED
A	REVISED PER NEW CODE	12/20/2021	R.L.

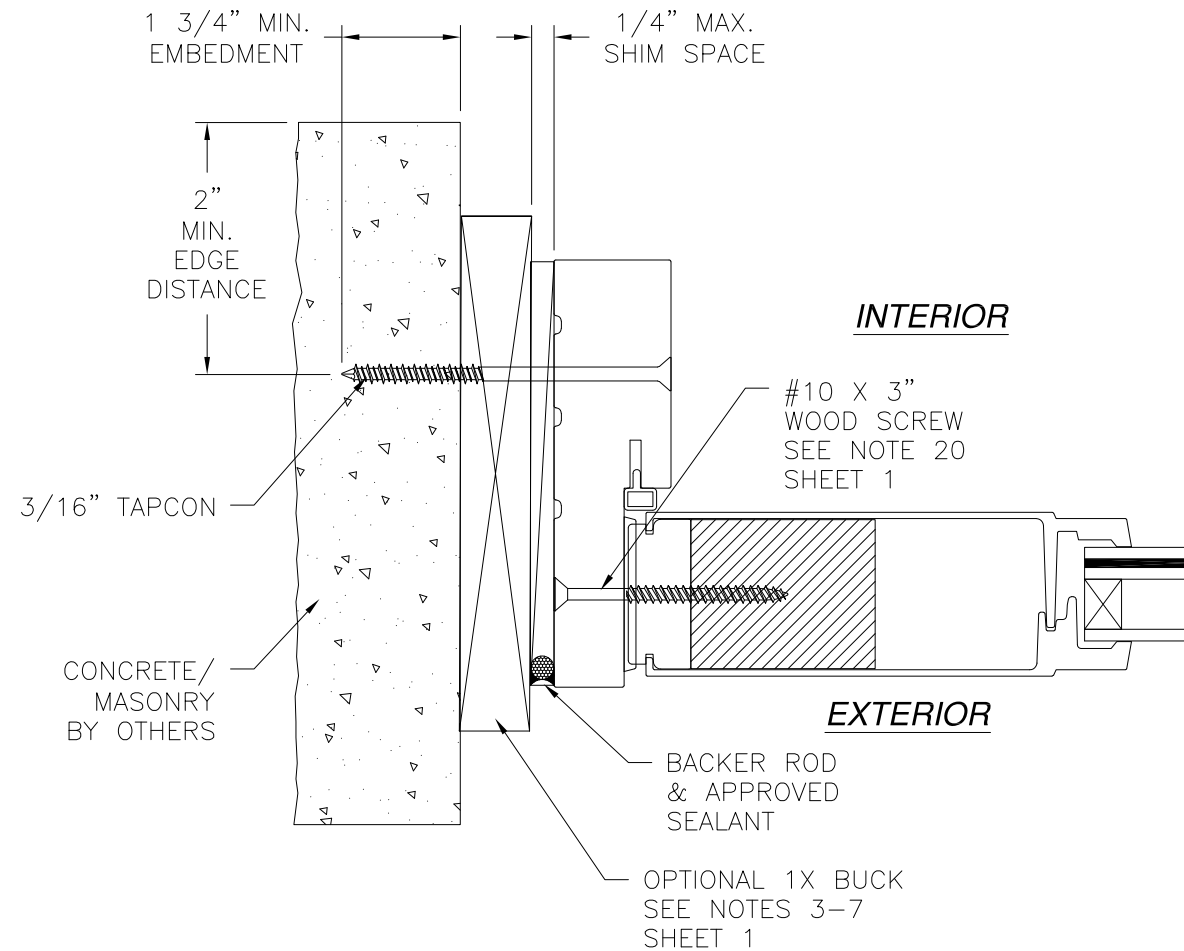
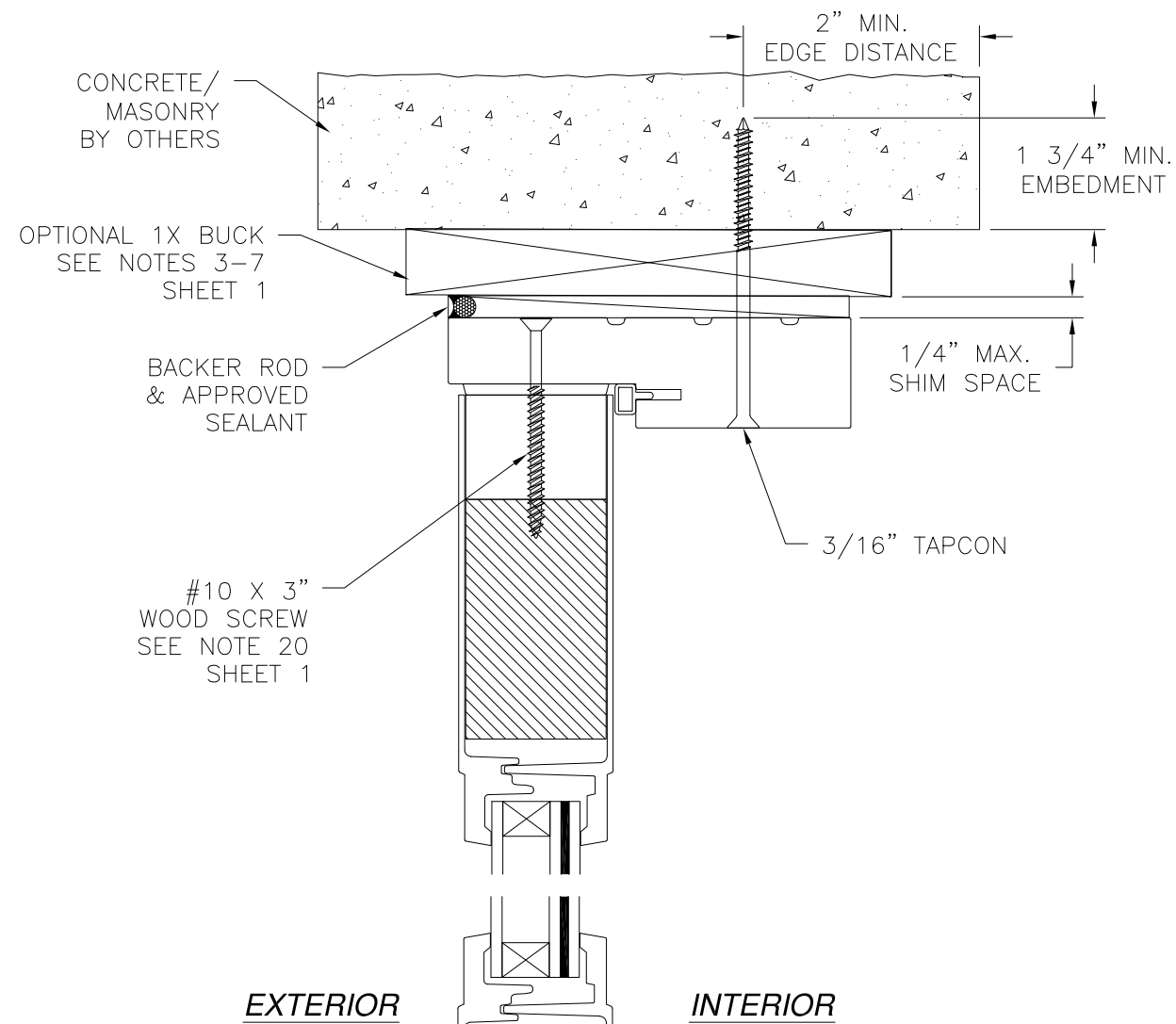

**SIDELITE INSTALLATION DETAIL**  
CONCRETE/MASONRY INSTALLATION  
STANDARD FRAME SHOWN, SOFT PVC FRAME SIMILAR

**NOTES:**

1. INTERIOR AND EXTERIOR FINISHES, BY OTHERS, NOT SHOWN FOR CLARITY.
2. PERIMETER AND JOINT SEALANT BY OTHERS TO BE DESIGNED IN ACCORDANCE WITH ASTM E2112

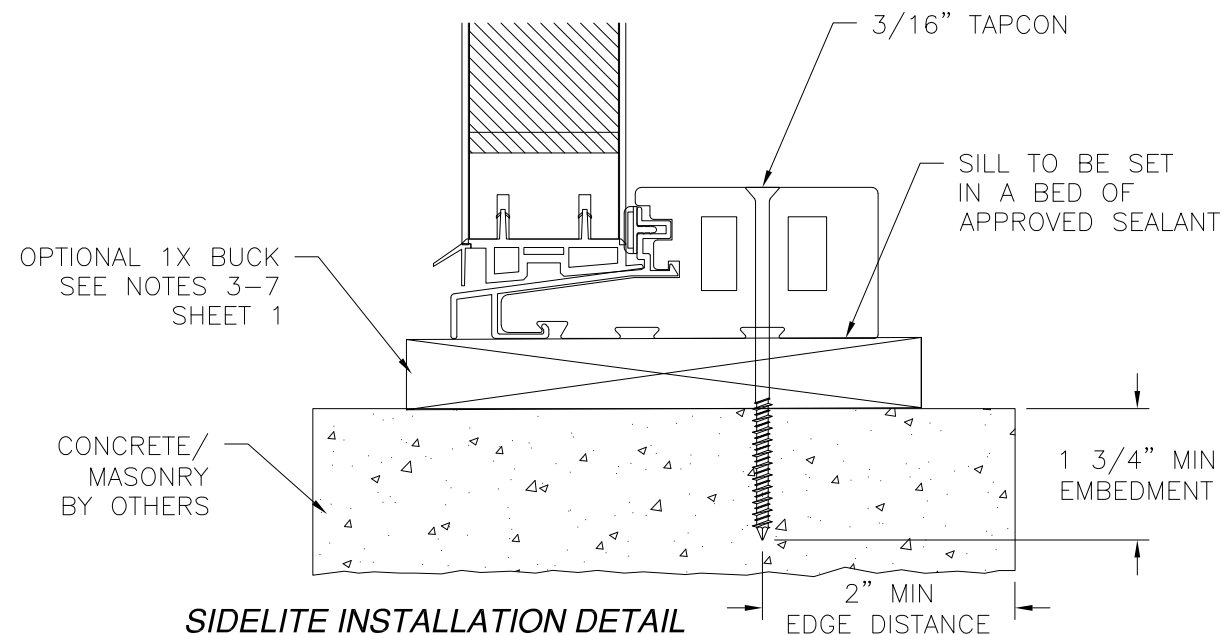

**SIDELITE INSTALLATION DETAIL**  
CONCRETE/MASONRY INSTALLATION  
STANDARD FRAME SHOWN, SOFT PVC FRAME SIMILAR

SIGNED: 12/20/2021

NAN YA PLASTICS CORP. USA  
8989 NORTH LOOP EAST  
HOUSTON, TX 77029

SLPS PATIO DOOR LITE 6'11" OUT-SWING  
LARGE MISSILE IMPACT  
SIDELITE INSTALLATION DETAILS

DRAWN: A.R.	DWG NO. 08-03342	REV A
SCALE NTS	DATE 10/29/18	SHEET 11 OF 14

L. ROBERTO LOMAS P.E.  
1432 WOODFORD RD LEWISVILLE, NC 27023  
434-688-0609 rllomas@rlomaspe.com



Luis R. Lomas P.E.  
TX No.: 101889  
Firm No: F-23130

REVISIONS			
REV	DESCRIPTION	DATE	APPROVED
A	REVISED PER NEW CODE	12/20/2021	R.L.

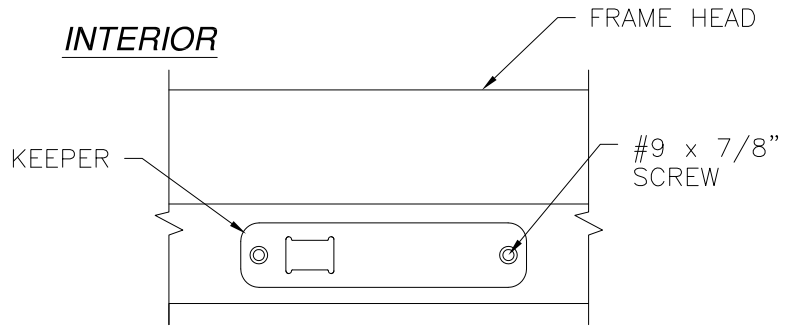

**EXTERIOR**  
**HEAD KEEPER DETAIL**

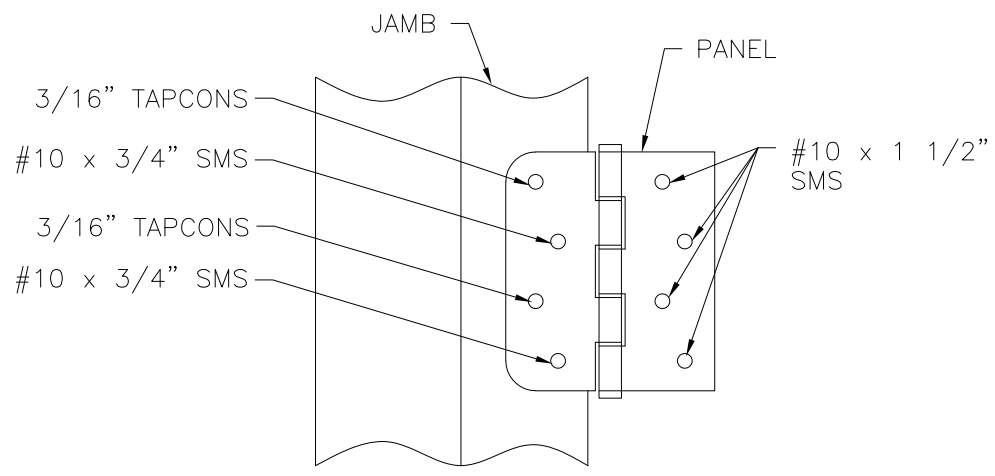

**HINGE INSTALLATION DETAIL**  
**MASONRY/CONCRETE INSTALLATION**

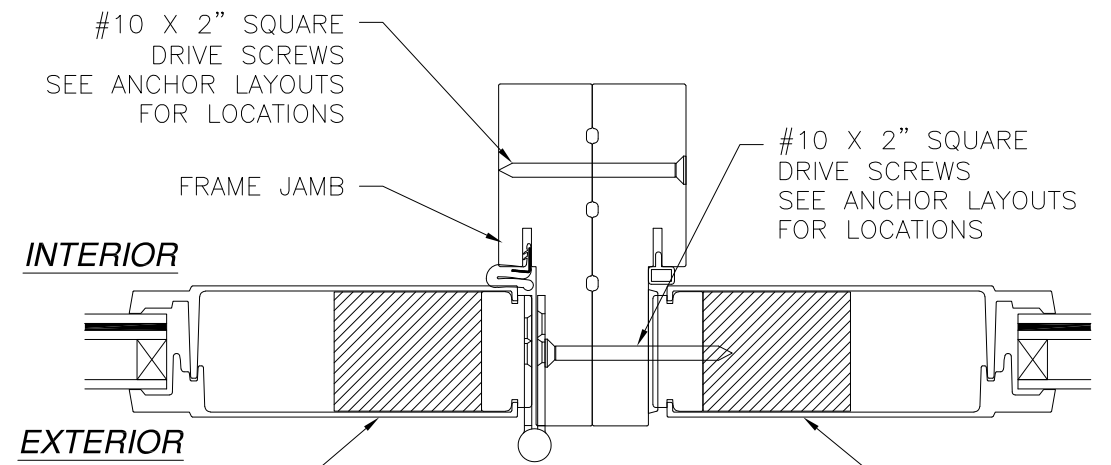

**MULLION DETAIL**  
**DOOR ANCHORS SCREWS**  
**NOT SHOWN FOR CLARITY**

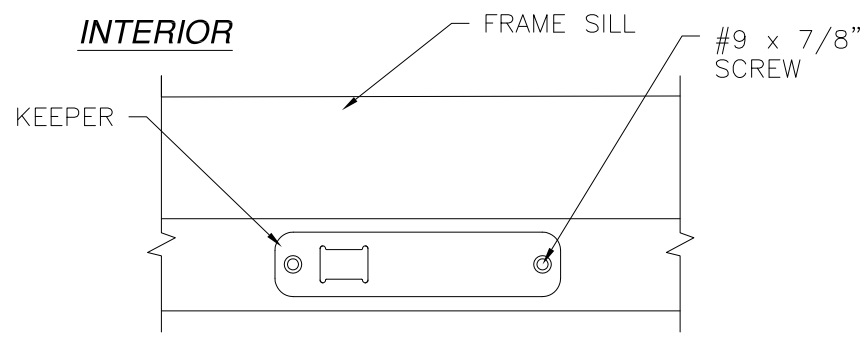

**EXTERIOR**  
**SILL KEEPER DETAIL**

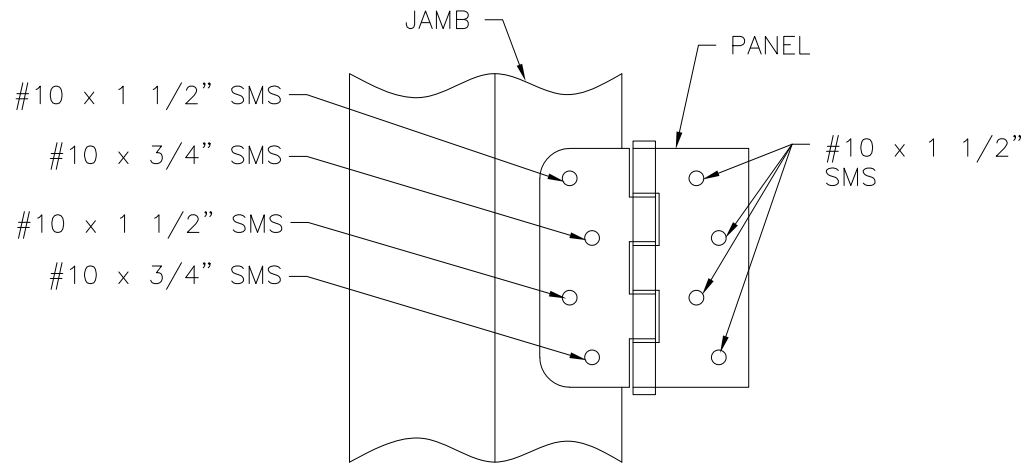

**HINGE INSTALLATION DETAIL**  
**WOOD AND METAL INSTALLATION**

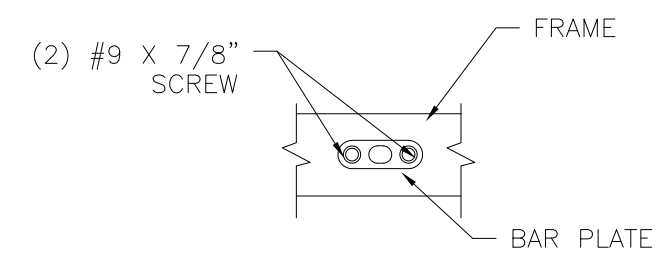

**DRIVE BAR PLATE DETAIL**

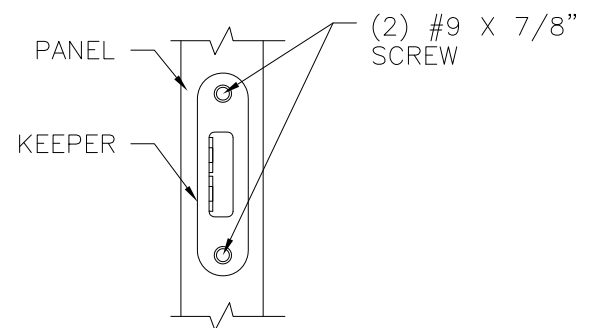

**HOOK KEEPER DETAIL**

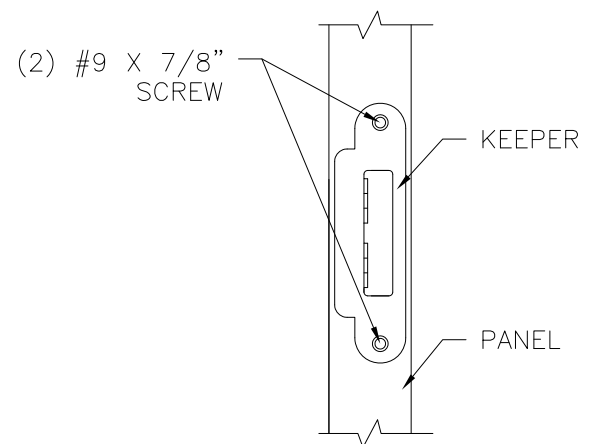

**SLAB MULTI-POINT**  
**LOCK KEEPER DETAIL**

SIGNED: 12/20/2021

NAN YA PLASTICS CORP. USA  
8989 NORTH LOOP EAST  
HOUSTON, TX 77029

SLPS PATIO DOOR LITE 6'11" OUT-SWING  
LARGE MISSILE IMPACT  
INSTALLATION DETAILS

DRAWN: A.R.	DWG NO. 08-03342	REV A
SCALE NTS	DATE 10/29/18	SHEET 12 OF 14

L. ROBERTO LOMAS P.E.  
1432 WOODFORD RD LEWISVILLE, NC 27023  
434-688-0609 rllomas@rlomaspe.com



Luis R. Lomas P.E.  
TX No.: 101889  
Firm No: F-23130

REVISIONS			
REV	DESCRIPTION	DATE	APPROVED
A	REVISED PER NEW CODE	12/20/2021	R.L.

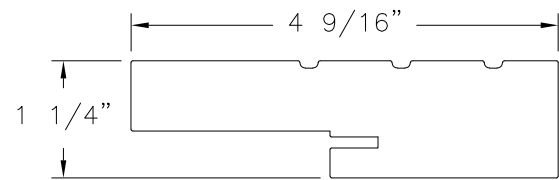

**HEAD FRAME & JAMB**  
FOAM PVC CO-EX

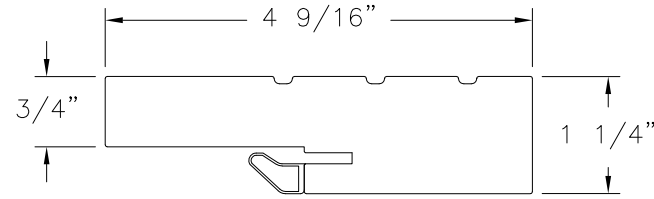

**FRAME SOFT PVC**  
FOAM PVC CO-EX

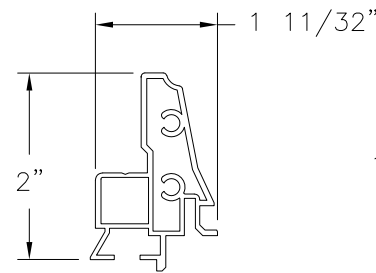

**REINFORCEMENT (B)**  
ALUMINUM

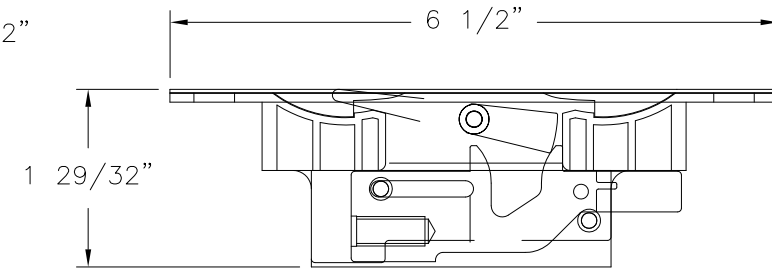

**FLUSH BOLT MECHANISM**  
DIE CAST, STEEL, POM (SS93X) BY JAM YUAN ENTERPRISES CO., LTD.

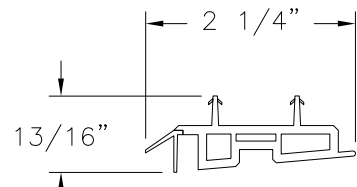

**DOOR BOTTOM-B**  
PVC CO-EX

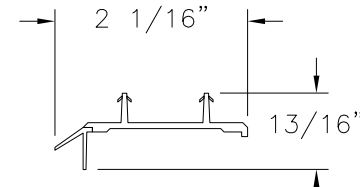

**DOOR BOTTOM-A**  
PVC CO-EX

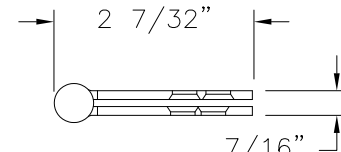

**4" X 4" DOOR HINGE**  
STEEL

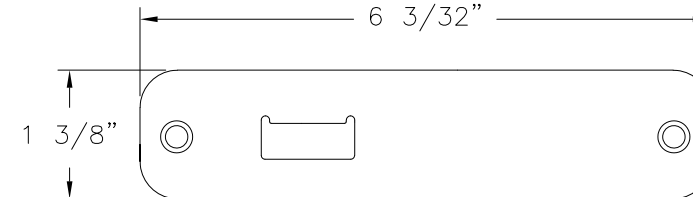

**TOP/BOTTOM BAR KEEPER**  
STAINLESS STEEL (SS92H)  
BY JAM YUAN ENTERPRISES CO., LTD.

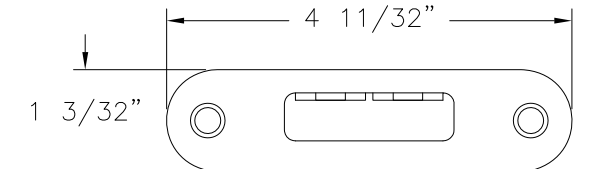

**HOOK KEEPER**  
STAINLESS STEEL (SS92G)  
BY JAM YUAN ENTERPRISES CO., LTD.

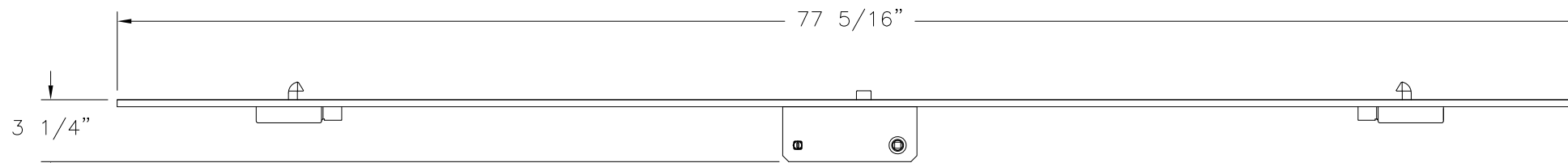

**MULTI-POINT LOCKING SYSTEM**  
STAINLESS STEEL BY JAM YUAN ENTERPRISES CO., LTD.

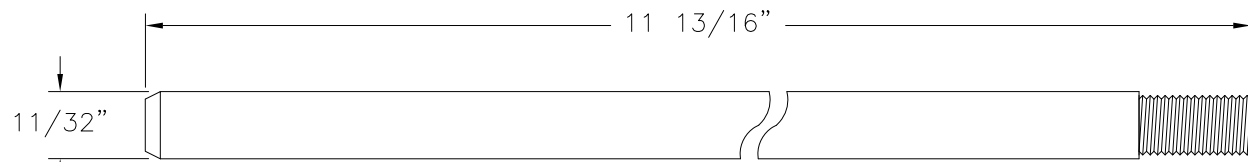

**FLUSH BOLT BAR**  
STAINLESS STEEL (SS93B) BY JAM YUAN ENTERPRISES CO., LTD.

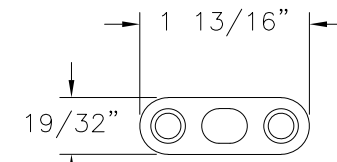

**DRIVE BAR PLATE**  
STAINLESS STEEL  
BY JAM YUAN ENTERPRISES CO., LTD.

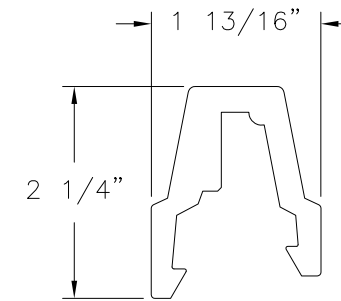

**MULLION COVER (B)**  
FOAM PVC

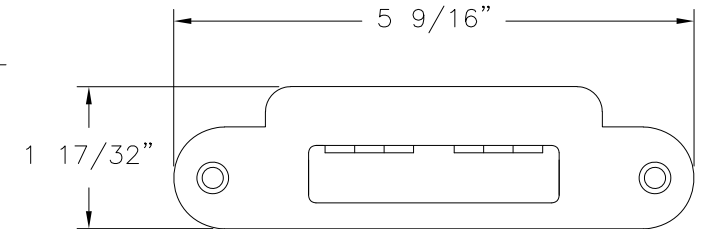

**SLAB MULTI-POINT LOCK KEEPER**  
STEEL BY JAM YUAN ENTERPRISES CO., LTD.

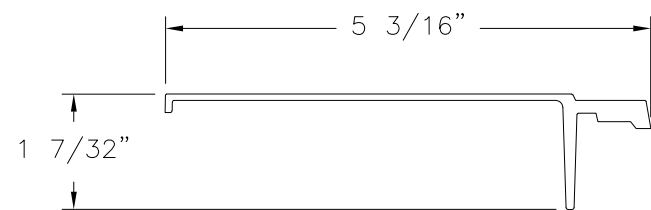

**SHEET MOLDING COMPOUND SKIN-1**  
FIBERGLASS

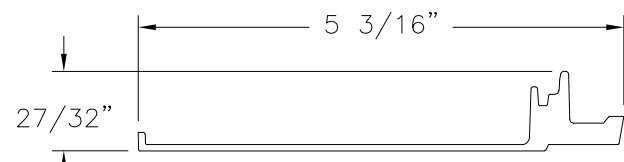

**SHEET MOLDING COMPOUND SKIN-2**  
FIBERGLASS

SIGNED: 12/20/2021

NAN YA PLASTICS CORP. USA  
8989 NORTH LOOP EAST  
HOUSTON, TX 77029

SLPS PATIO DOOR LITE 6'11" OUT-SWING  
LARGE MISSILE IMPACT  
COMPONENTS

DRAWN: A.R.	DWG NO. 08-03342	REV A
SCALE NTS	DATE 10/29/18	SHEET 13 OF 14

L. ROBERTO LOMAS P.E.  
1432 WOODFORD RD LEWISVILLE, NC 27023  
434-688-0609 rllomas@rlomaspe.com



Luis R. Lomas P.E.  
TX No.: 101889  
Firm No: F-23130

REVISIONS			
REV	DESCRIPTION	DATE	APPROVED
A	REVISED PER NEW CODE	12/20/2021	R.L.

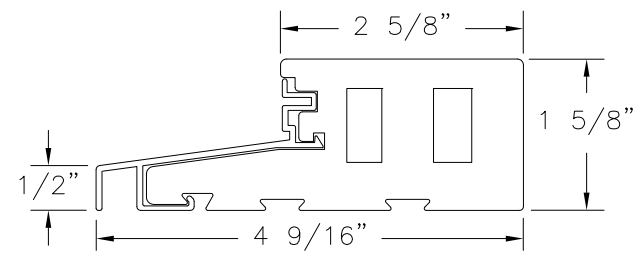

**OUTSWING DOOR SILL DETAIL**

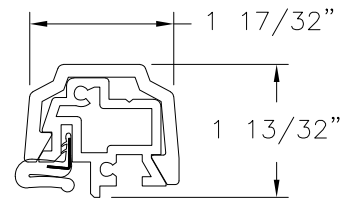

**T-ASTRAGAL  
RIGID PVC**

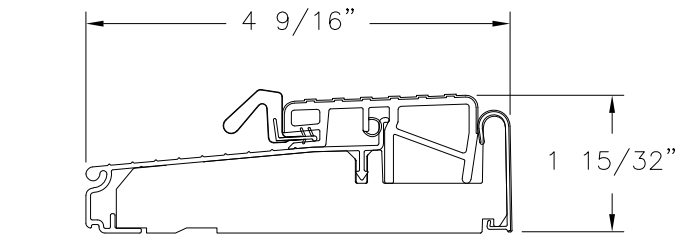

**OUTSWING THRESHOLD ZOB4565FN  
ALTERNATE**

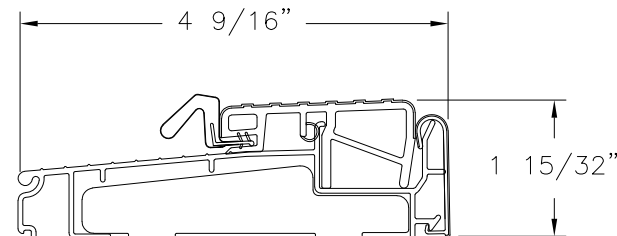

**OUTSWING THRESHOLD ZOBL4565  
ALTERNATE**

SIGNED: 12/20/2021

NAN YA PLASTICS CORP. USA 8989 NORTH LOOP EAST HOUSTON, TX 77029		
SLPS PATIO DOOR LITE 6'11" OUT-SWING LARGE MISSILE IMPACT COMPONENTS		
DRAWN: A.R.	DWG NO. 08-03342	REV A
SCALE NTS	DATE 10/29/18	SHEET 14 OF 14
L. ROBERTO LOMAS P.E. 1432 WOODFORD RD LEWISVILLE, NC 27023 434-688-0609 rllomas@lrlomaspe.com		



Luis R. Lomas P.E.  
TX No.: 101889  
Firm No: F-23130