

WINCORE™

WINDOWS & DOORS

250 Staunton Turnpike, Parkersburg, WV 26104

Series 8400 Vinyl Sliding Patio Door "NON-IMPACT"

EVALUATED FOR USE IN THE STATE OF TEXAS

The Wincore Sliding Glass Door described herein complies with the 2018 International Residential Code (IRC), Sections R301 & R609 and the 2018 International Building Code (IBC), Sections 1404.13, 1609, 1709.5, 2403 and 2404 subject to the following conditions:

1. Anchors shall be as listed and spaced as shown in the details. Anchor embedment to base material shall be beyond roof covering.
2. When used in areas requiring wind-borne debris protection this product is required to be protected with an impact resistant covering that complies with Section R301.2.1.2 of the IRC and Section 1609.1.2 of the IBC.
3. Allowable design pressure requirements must be equal to or less than the design pressure rating shown in the design pressure chart, sheet 1 of this drawing.
4. Conditions not covered by this drawing are subject to further engineering analysis.

TABLE OF CONTENTS

SHEET#	DESCRIPTION
1	Typical elevation, design pressures & general notes
2	Horizontal cross sections
3	Vertical cross sections
4	Frame anchoring
5	Components
6	Bill of materials & glazing detail

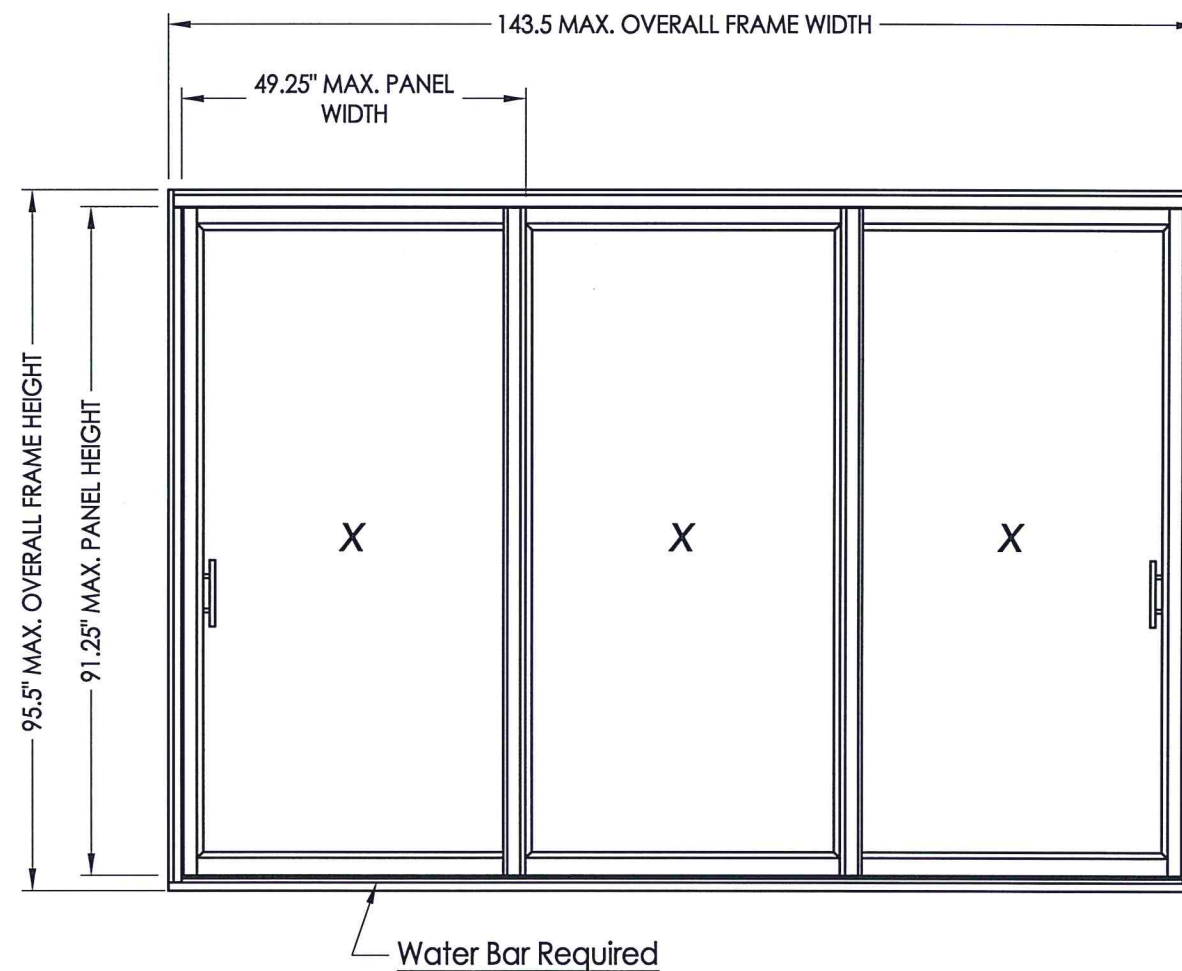

OVERALL FRAME DIMENSION	MAX. PANEL DIMENSION	MAX. D.L.O. DIMENSION	GLASS TYPE	DESIGN PRESSURE (PSF)	
				POSITIVE	NEGATIVE
143.5" x 95.5"	49.25" X 91.25"	42.375" X 85.0"	G1	+50.0	-50.0

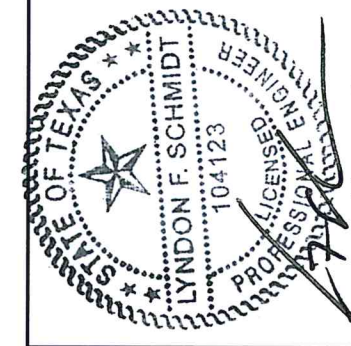

Documents Prepared By: Lyndon F. Schmidt, P.E.
TEXAS P.E. #104123

RW BUILDING CONSULTANTS, INC.
P.O. Box 230 Valrico FL 33595
Phone No.: 813.659.9197

TEXAS BOARD OF PROFESSIONAL ENGINEERS
CERTIFICATE OF REGISTRATION # F-11852

PRODUCT:	SLIDING GLASS DOORS		
PART OR ASSEMBLY:	TYPICAL ELEVATION, DESIGN PRESSURES & GENERAL NOTES		
NO.	DATE	BY	REVISIONS

DATE: 2/02/23
SCALE: N.T.S.
DWG. BY: LFS
CHK. BY: RW
DRAWING NO.: TX-5295
SHEET 1 OF 6

Z:\Clients\Wincore PERMANENT\B - (2018) Texas Dept of Ins\DR-XXXX SGD 8400\C - Drawings\TX-5295.dwg

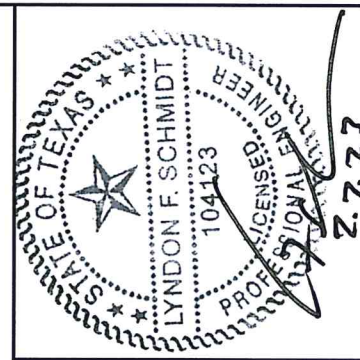
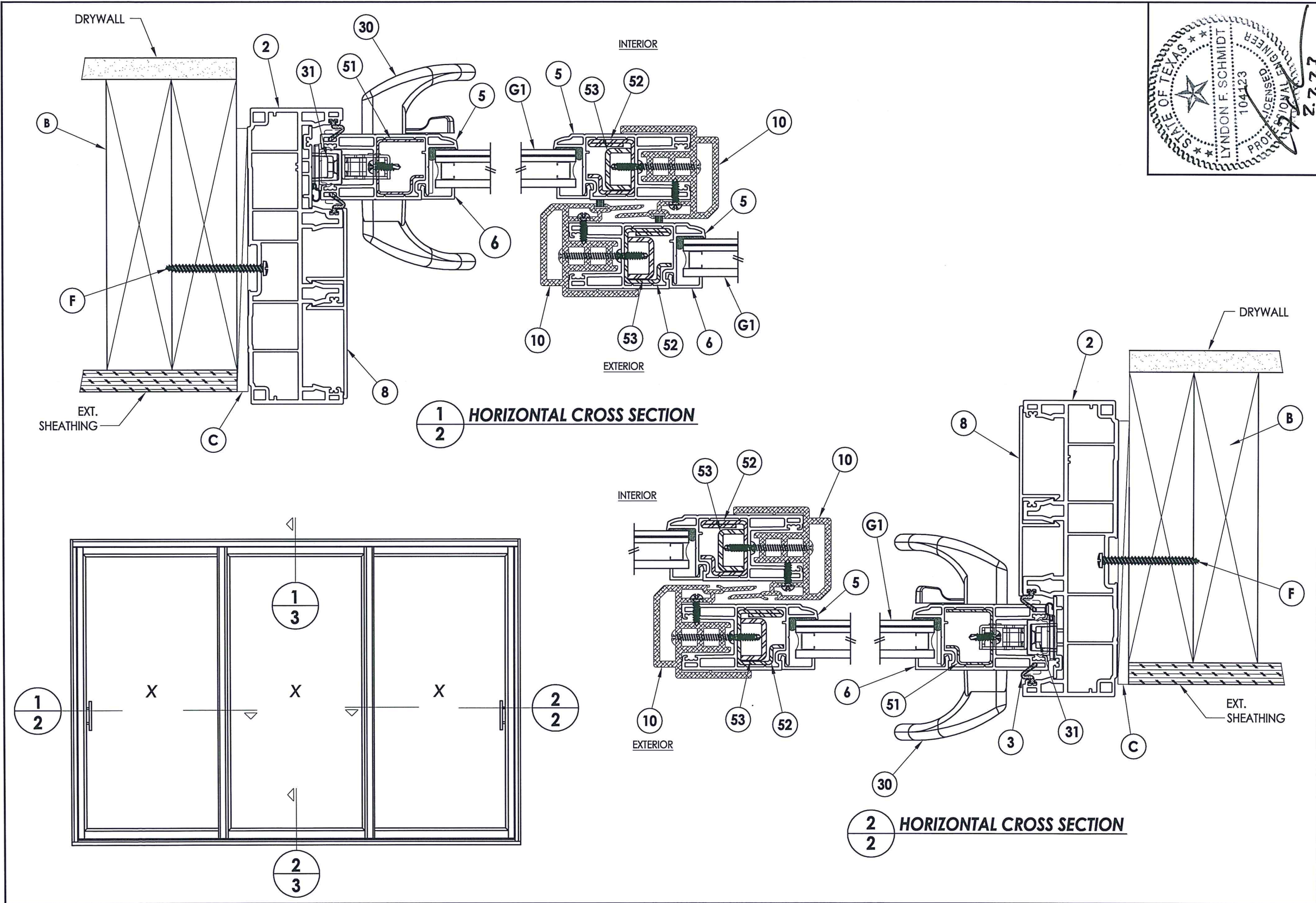

Documents Prepared By: Lyndon F. Schmidt, P.E.
 TEXAS P.E. #104123

RW BUILDING CONSULTANTS, INC.
 P.O. Box 230 Valrico FL 33595
 Phone No.: 813.659.9197

TEXAS BOARD OF PROFESSIONAL ENGINEERS
 CERTIFICATE OF REGISTRATION # F-11852

PRODUCT:	SLIDING GLASS DOORS
PART OR ASSEMBLY:	HORIZONTAL CROSS SECTIONS

NO.	DATE	REVISIONS	BY

DATE: 2/02/23
 SCALE: N.T.S.
 DWG. BY: LFS
 CHK. BY: RW
 DRAWING NO.: TX-5295
 SHEET 2 OF 6

© 2023 R.W. BUILDING CONSULTANTS INC.

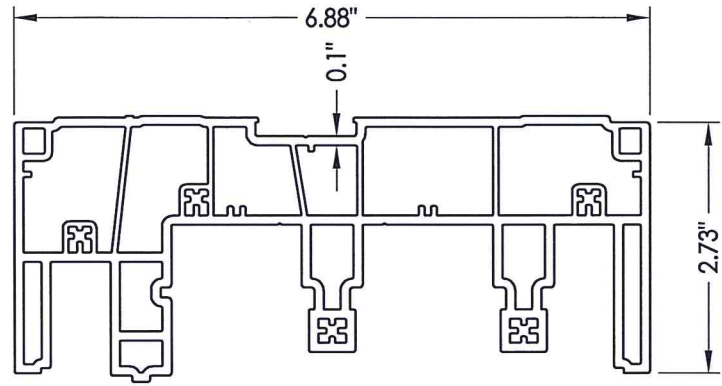

1 FRAME HEAD

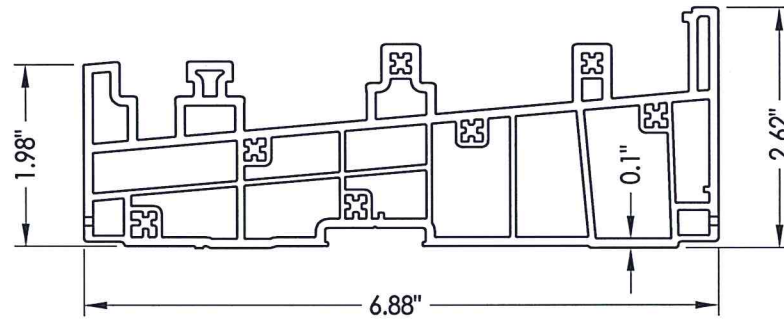

12 FRAME SILL

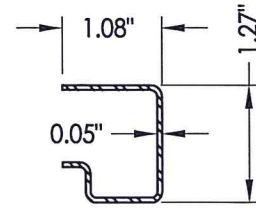

51 REINFORCEMENT
Lock Stile

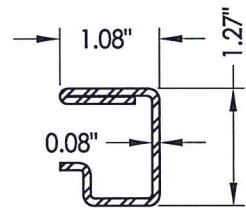

52 REINFORCEMENT
Meeting rail

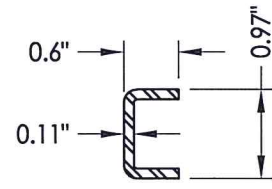

53 REINFORCEMENT
Meeting rail

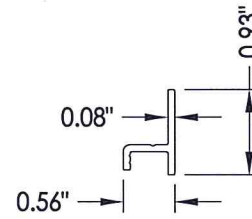

55 WATER BAR

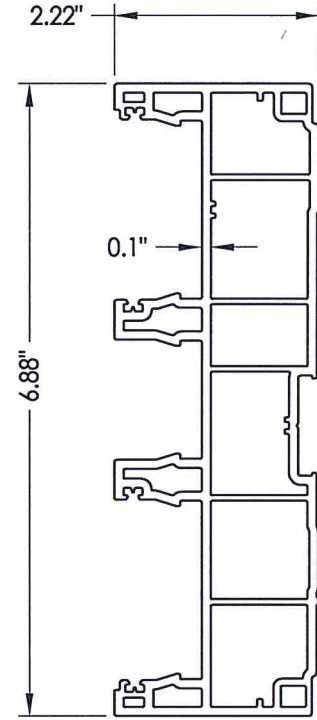

2 FRAME JAMB

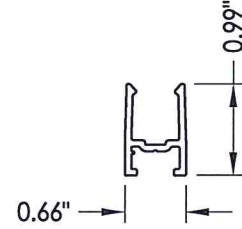

4 HEAD TRACK

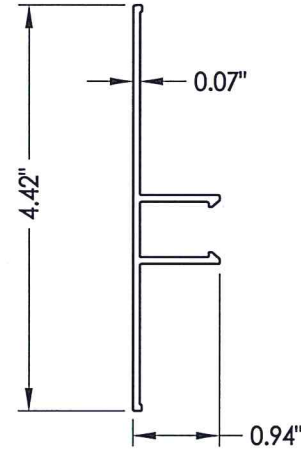

8 JAMB COVER

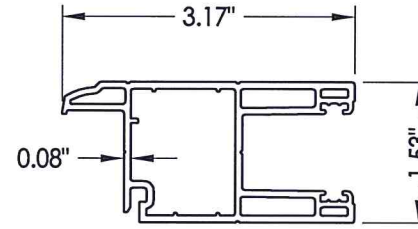

5 STILE & RAIL

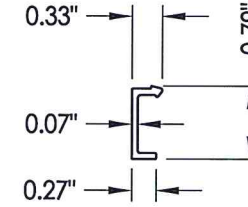

6 GLAZING BEAD

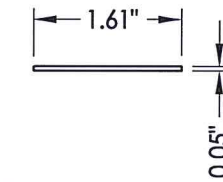

9 HEAD COVER

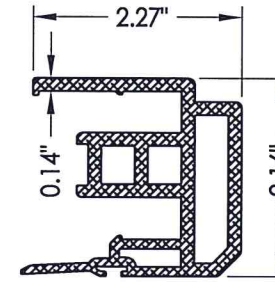

10 INTERLOCK

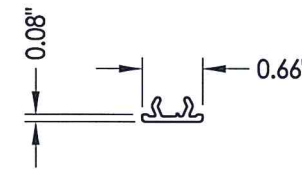

11 HEAD COVER RAIL

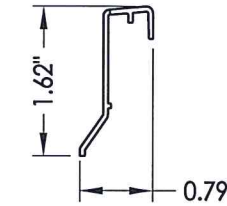

13 SILL CLADDING



Documents Prepared By: Lyndon F. Schmidt, P.E.
TEXAS P.E. #104123

RW BUILDING CONSULTANTS, INC.
P.O. Box 230 Valrico FL 33595
Phone No.: 813.659.9197

TEXAS BOARD OF PROFESSIONAL ENGINEERS
CERTIFICATE OF REGISTRATION # F-11852

PRODUCT: SLIDING GLASS DOORS

PART OR ASSEMBLY: COMPONENTS

NO.	DATE	REVISIONS	BY

DATE: 2/02/23

SCALE: N.T.S.

DWG. BY: LFS

CHK. BY: RW

DRAWING NO.:

TX-5295

SHEET 5 OF 6

BILL OF MATERIALS

ITEM #	DESCRIPTION	MATERIAL
B	2X FAGING(G >= 0.42)	WOOD
C	1/4" MAX. SHIM SPACE	-
D	1/4" X 2-3/4" FH DeWALT OR ITW CONCRETE SCREW	STEEL
F	#10 X 2 PH SMS (1-3/8" MIN. EMBEDMENT)	STEEL
P	1/4" PFH ELCO OR ITW CONCRETE SCREW (1-3/4" MIN. EMB.)	STEEL
1	FRAME HEAD*	PVC
2	FRAME JAMB*	PVC
3	WEATHERSTRIP	-
4	HEAD TRACK*	PVC
5	STILE & RAIL*	PVC
6	GLAZING BEAD (1" GLAZING)*	PVC
8	JAMB COVER*	PVC
9	HEAD COVER*	PVC
10	INTERLOCK	ALUM
11	HEAD COVER RAIL*	PVC
12	SILL*	PVC
13	SILL CLADDING	ALUM
16	SLIDING RAIL	ALUM
20	TANDEM WHEEL	-
21	TANDEM WHEEL SETTING BLOCK	PVC
30	HANDLE KIT	-
31	STAINLESS STEEL DOUBLE POINT MORTISE LOCK KIT	STEEL
32	INERTIOR HANDLE KIT	-
51	LOCK STILE REINFORCEMENT	STEEL
52	MEETING STILE REINFORCEMENT	STEEL
53	MEETING STILE REINFORCEMENT	STEEL
55	WATER BAR	ALUM
56	#8 X 1" PPH SMS	SS

* THE APPROVED WHITE RIGID PVC EXTERIOR EXTRUSIONS FOR WINDOWS ARE TO BE PRODUCED BY EXTRUDERS LICENSEES IN "AAMA CERTIFICATION PROGRAMS FOR RIGID PVC EXTRUSIONS".

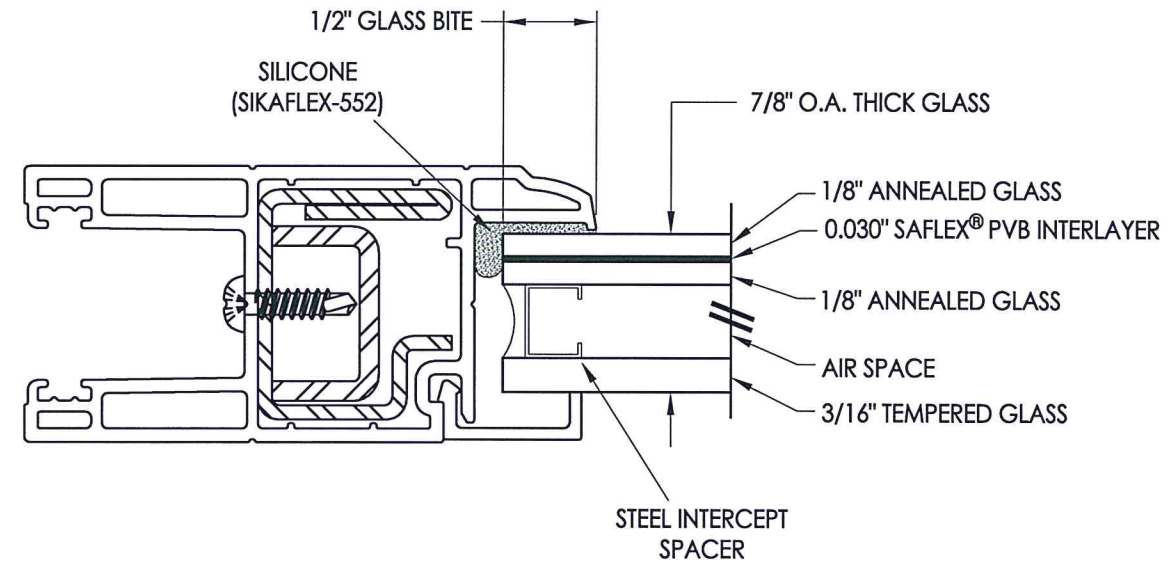

G1 GLAZING DETAIL

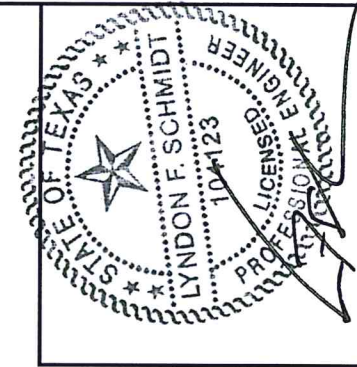

2-7-23

Documents Prepared By: Lyndon F. Schmidt, P.E.
TEXAS P.E. #104123

RW BUILDING CONSULTANTS, INC.
P.O. Box 230 Valrico FL 33595
Phone No.: 813.659.9197

TEXAS BOARD OF PROFESSIONAL ENGINEERS
CERTIFICATE OF REGISTRATION # F-11852

PRODUCT:	SLIDING GLASS DOORS
PART OR ASSEMBLY:	BILL OF MATERIALS & GLAZING

NO.	DATE	BY	REVISIONS

DATE:	2/02/23
SCALE:	N.T.S.
DWG. BY:	LFS
CHK. BY:	RW
DRAWING NO.:	TX-5295
SHEET	6 OF 6