

Notes:

1. This is a special configuration we will not sell to customers. This is being tested to qualify numerous other configurations.
2. Test sample to come with screens.
3. Color to be white.
4. Test I.D. frame size to be 190 5/8" x 120".
5. Will test one unit reinforced and one unit non-reinforced.
6. By testing finless, flange will be qualified.
7. Non-Impact Glass 3/8" Temp./airspace/3/16" Temp.
8. Impact Glass 4.7I/airspace/(4.7-.100HP-4.7).
9. Test units to have both sill risers for testing.

Report #: 1435.05-106-12
 Date: 5/9/2018
 By: M. Stremmel

				MATERIAL:		MI WINDOWS AND DOORS, LLC. 650 WEST MARKET STREET GRATZ, PA 17030-0370	DESCRIPTION: Cross Sectional Drawing 130 3-Track XIX-0	
				FINISH:	UNSPECIFIED WALL:		PRODUCT: Special 130	
				AREA:	BREAK ALL CORNERS R.015, UNLESS OTHERWISE SPECIFIED		DATE: 10/13/17	
				WEIGHT:			SCALE: 1 : 4	
				PERIMETER:			PART NUMBER:	
-	122B-17	Initial release for R&D test units	10/13/17	T.C.	DFTM: T.C.		DRAWING NUMBER: CS-000545	
LTR	ECN #	REVISIONS	DATE	BY				

Actual Size

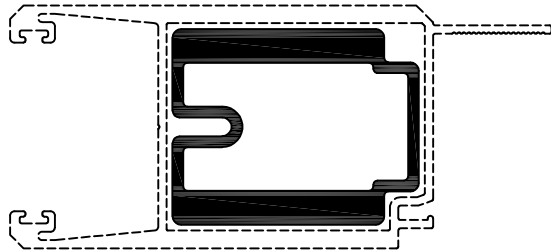
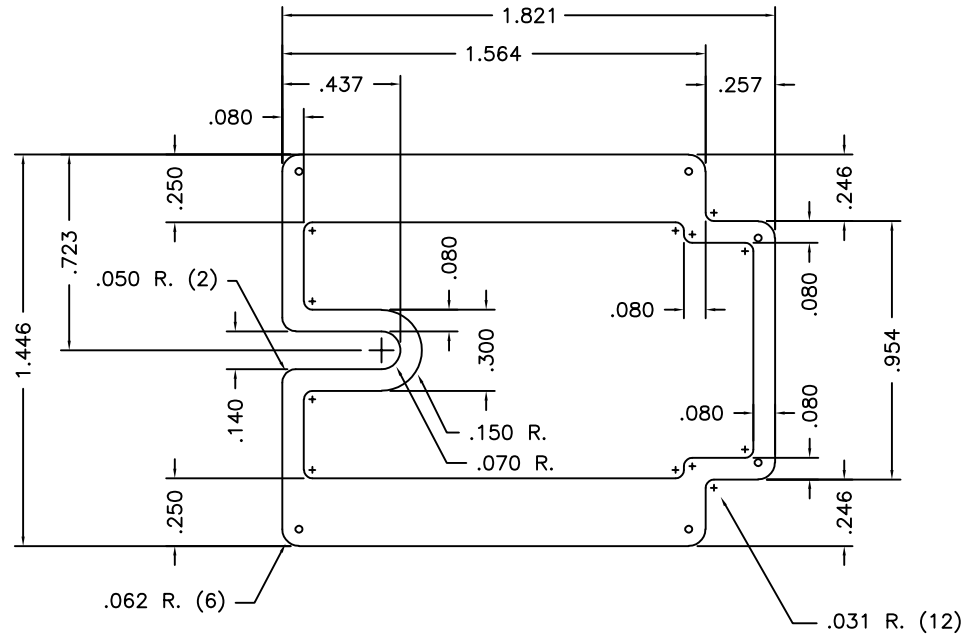
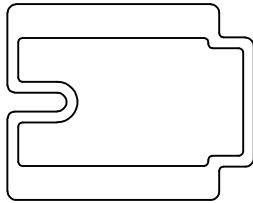

Molimo
Architectural Product Testing

Report #: 1435.05-106-12

Date: 5/9/2018

By: M. Stremmel

Description	Length	Finish	8-Digit Part #
Panel Interlock Rebar	192"	Mill	M2516000

CLASS: Hollow	PAINT PERIMETER: None
THERMAL CAVITY: None	CIRCLE SIZE: 2.250

					MATERIAL: 6005-T5	 650 WEST MARKET STREET GRATZ, PA 17030-0370 The information, design or data shown on this document or electronic media is the exclusive property of MI Windows and Doors, LLC. It is considered confidential and proprietary and is made available for limited use only. Its use or reproduction without the expressed written consent of MI Windows and Doors, LLC., is prohibited.	DESCRIPTION: Meeting Rail Stile Reinforcement Aluminum Extrusion		
					FINISH: Mill		UNSPECIFIED WALL: .080	PRODUCT: 120/130/140 Families	DATE: 06/05/15
					AREA: 1.032		BREAK ALL CORNERS R.015, UNLESS OTHERWISE SPECIFIED	SCALE: 2 : 1	PART NUMBER: M-2516
					WEIGHT: 1.239			PERIMETER: 12.944	DFTM: T.C.
-	113A-16	Initial release for extrusion tooling	08/08/16	T.C.					
LTR	ECN #	REVISIONS	DATE	BY					

130, 4-Panel, 3-Track, XIX-O, Test Unit

Last Updated 10/13/17

Description	MIWD Part No.	Vendor Part No.	Rev.	CAD	Color	UOM	Qty
MAIN FRAME :							
Frame Head, Finless, White	M252000C	M-2520	-	yes	White	Ft.	1
Frame Head, Finless, Driftwood	M252000D	M-2520	-	yes	Driftwood	Ft.	1
Frame Head, Finless, Bronze	M252000B	M-2520	-	yes	Bronze	Ft.	1
Frame Head Track Fillers, White	M251200C	M-2512	-	yes	White	Ft.	3
Frame Head Track Fillers, Driftwood	M251200D	M-2512	-	yes	Driftwood	Ft.	3
Frame Head Track Fillers, Bronze	M251200B	M-2512	-	yes	Bronze	Ft.	3
Frame Sill, Finless and Flange, Mill	M2522000	M-2522	-	yes	Mill	Ft.	1
Roller Track for Frame Sill, Finless and Flange, Mill	M2512000	M-2511	-	yes	Mill	Ft.	3
Optional Frame Sill Riser, Finless and Flange, 2.625 Ht., Mill	M2530000	M-2530	-	yes	Mill	Ft.	1
Optional Frame Sill Riser, Finless and Flange, 3.500 Ht., Mill	M2531000	M-2531	-	yes	Mill	Ft.	1
Frame Jambs, Finless, White	M252300C	M-2523	-	yes	White	Ft.	2 (1 LH/1 RH)
Frame Jambs, Finless, Driftwood	M252300D	M-2523	-	yes	Driftwood	Ft.	2 (1 LH/1 RH)
Frame Jambs, Finless, Bronze	M252300B	M-2523	-	yes	Bronze	Ft.	2 (1 LH/1 RH)
Frame Jamb Fillers, Finless and Flange, White	M251200C	M-2512	-	yes	White	Ft.	6
Frame Jamb Fillers, Finless and Flange, Driftwood	M251200D	M-2512	-	yes	Driftwood	Ft.	6
Frame Jamb Fillers, Finless and Flange, Bronze	M251200B	M-2512	-	yes	Bronze	Ft.	6
Standard Handle Set, "D" Shaped Pulls, Non-Keyed, White	HD50002C		-	no	White	Ea.	2
Standard Handle Set, "D" Shaped Pulls, Non-Keyed, Driftwood	HD50002D		-	no	Driftwood	Ea.	2
Standard Handle Set, "D" Shaped Pulls, Non-Keyed, Black	HD50002L		-	no	Bronze	Ea.	2
Panel Adapter - White	M251800C	M-2518	-	yes	White	Ft.	1
Panel Adapter - Driftwood	M251800D	M-2518	-	yes	Driftwood	Ft.	1
Panel Adapter - Bronze	M251800B	M-2518	-	yes	Bronze	Ft.	1
Screw Package Containing the Following							
Frame Gasket Set, LH & RH, Head - Gray	MS50051C		-	no	Gray	Ea.	1
Frame Gasket Set, LH & RH, Head - Black	MS50051L		-	no	Black	Ea.	1
Frame Gasket Set, LH & RH, Sill - Gray	MS50050C		-	no	Gray	Ea.	1



Report #: 1435.05-106-12
 Date: 5/9/2018
 By: M. Stremmel

Frame Gasket Set, LH & RH, Sill - Black	MS50050L		-	no	Black	Ea.	1
#8 x 3/4" PPHSMS 410 Stainless - Frame Assembly	FS001730			no		Ea.	14
3/8" Dia Hole Plugs for Adjustment Holes - White	WS30025C		-	no	Nylon	Ea.	8
3/8" Dia Hole Plugs for Adjustment Holes - Driftwood	WS30025D		-	no	Nylon	Ea.	8
3/8" Dia Hole Plugs for Adjustment Holes - Bronze	WS30025B		-	no	Nylon	Ea.	8
.750 Hi x 1.250 W x 3.000 L, w-strip pad, adhesive, over and under interlocks	WS40000G	751250GYAD3000	-	no	Syn. Pile	Ea.	6
Bump Stop, Base and Cover Set, White	IM20800C		-	yes	White	Ea.	2
Bump Stop, Base and Cover Set, Bronze	IM20800B		-	yes	Bronze	Ea.	2
Bump Stop, Base and Cover Set, Driftwood	IM20800D		-	yes	Driftwood	Ea.	2
#8 x 1" PPH TEK, Attach Bump Stop, White	FS00309C		-	no	White	Ea.	4
#8 x 1" PPH TEK, Attach Bump Stop, Adobe	FS00309J		-	no	Adobe	Ea.	4
#8 x 1" PPH TEK, Attach Bump Stop, Bronze	FS00309Q		-	no	Bronze	Ea.	4
Fixed Panel Retainer Bracket, White	M251900C	M-2519	-	yes	White	Ft.	4
Fixed Panel Retainer Bracket, Driftwood	M251900D	M-2519	-	yes	Driftwood	Ft.	4
Fixed Panel Retainer Bracket, Bronze	M251900B	M-2519	-	yes	Bronze	Ft.	4
#8 x 1" PPH TEK, Attach Fixed Panel Retainer to panel and Frame Jamb, White	FS00309C		-	no	White	Ea.	16
#8 x 1" PPH TEK, Attach Fixed Panel Retainer to panel and Frame Jamb, Adobe	FS00309J		-	no	Adobe	Ea.	16
#8 x 1" PPH TEK, Attach Fixed Panel Retainer to panel and Frame Jamb, Bronze	FS00309Q		-	no	Bronze	Ea.	16
"X" and "xx" Panel: One of each Required, One LH and One RH. Caution Inside VS Outside Tracks.							
Panel Top Rail, White	M250000C	M-2500	-	yes	White	Ft.	1
Panel Top Rail, Driftwood	M250000D	M-2500	-	yes	Driftwood	Ft.	1
Panel Top Rail, Bronze	M250000B	M-2500	-	yes	Bronze	Ft.	1
Panel Bottom Rail, White	M250000C	M-2500	-	yes	White	Ft.	1
Panel Bottom Rail, Driftwood	M250000D	M-2500	-	yes	Driftwood	Ft.	1
Panel Bottom Rail, Bronze	M250000B	M-2500	-	yes	Bronze	Ft.	1
.187 x .250 Weatherstrip for top and bottom rails and injection molded filler	WS30060G		-	no	Grey	Ft.	4
.750 Hi x 1.250 W x 1.500 L, w-strip pad, adhesive, Each end of top/bottom rails	WS40001G	751250GYAD1500	-	no	Syn. Pile	Ea.	4
Panel Stiles, White	M250200C	M-2502	-	yes	White	Ft.	2
Panel Stiles, Driftwood	M250200D	M-2502	-	yes	Driftwood	Ft.	2
Panel Stiles, Bronze	M250200B	M-2502	-	yes	Bronze	Ft.	2



Report #: 1435.05-106-12
Date: 5/9/2018
By: M. Stremmel

.187 x .250 Weatherstrip (Lock Stile)	WS30060G		-	no	Grey	Ft.	2
Optional Rebar for Interlock Stile - Mill	M2516000	M-2516	-	yes	Mill	Ft.	1
Weatherstrip Plug, Injection Moulded, Each Corner	IM355000		-	yes	Black	Ea.	4
#10 x 1" Hex Head SMS, S.S., Panel Assembly	FS002561				SS	Ea.	8
Panel Roller, Tandem, SS, Precision, 1.500, With Spacer	HD300300	SS7143DSPA	-	yes	eel/Compos	Ea.	2
#8 x 1/2" PFHMSA, Attach Rollers to Bottom Rail	FS003073		-	no	ZI PL ST	Ea.	4
Setting Blocks for Glass - 1/8" x 1" x 1"	MS100090	PSA-1			Black	Ea.	Varies
Backbedding - Pecora 896 610 Trans TBS UV03B	SL000760	Pecora 896 Clr.			Clear	Gal.	Varies
Glass as Required, IG, Impact, NON-Impact						Ea.	1
Glazing Bead, IG, Impact and Non-Impact - White	M250500C	M-2505	-	yes	White	Ft.	2 Hor./2 Vert.
Glazing Bead, IG, Impact and Non-Impact - Driftwood	M250500D	M-2505	-	yes	Driftwood	Ft.	2 Hor./2 Vert.
Glazing Bead, IG, Impact and Non-Impact - Bronze	M250500B	M-2505	-	yes	Bronze	Ft.	2 Hor./2 Vert.
.187 x .160 w'strip for glazing beads	WS10024G				Gray	Ft.	2 hor./2 vert.
Panel Interlock - White	M250300C	M-2503	-	yes	White	Ft.	1
Panel Interlock - Driftwood	M250300D	M-2503	-	yes	Driftwood	Ft.	1
Panel Interlock - Bronze	M250300B	M-2503	-	yes	Bronze	Ft.	1
.187 x .250 Weatherstrip for Panel Interlock	WS30060G		-	no	Grey	Ft.	1
Bulb Seal fo Panel Interlock	MS50021L	PPI 0791-1	-	no	Black	Ft.	1
#8 x 7/8" PPHTK, Attach Interlock to Panel Stile	FS001390		-	no	Mill	Ea.	5
Interlock Screw Cover, Snap-In - White	M250400C	M-2504	-	yes	White	Ft.	1
Interlock Screw Cover, Snap-In - Adobe	M250400D	M-2504	-	yes	Driftwood	Ft.	1
Interlock Screw Cover, Snap-In - Bronze	M250400B	M-2504	-	yes	Bronze	Ft.	1
Dual Mortise Lock Set w/faceplate, Stainless Steel	L0000160	Gemini II	-	no	Stainless	Ea.	1
#8 x 1/2" PFHMSA, Attach Mortise Lock to Lock Stile	FS003073		-	no	ZI PL ST	Ea.	2



MolimoTM
Architectural Product Testing

Report #: 1435.05-106-12

Date: 5/9/2018

By: M. Stremmel

"I" Panel							
Panel Top Rail, White	M250000C	M-2500	-	yes	White	Ft.	1
Panel Top Rail, Driftwood	M250000D	M-2500	-	yes	Driftwood	Ft.	1
Panel Top Rail, Bronze	M250000B	M-2500	-	yes	Bronze	Ft.	1
Panel Bottom Rail, White	M250000C	M-2500	-	yes	White	Ft.	1
Panel Bottom Rail, Driftwood	M250000D	M-2500	-	yes	Driftwood	Ft.	1
Panel Bottom Rail, Bronze	M250000B	M-2500	-	yes	Bronze	Ft.	1
.187 x .250 Weatherstrip for top and bottom rails and injection molded filler	WS30060G		-	no	Grey	Ft.	4
.750 Hi x 1.250 W x 1.500 L, w-strip pad, adhesive, Each end of top/bottom rails	WS40001G	751250GYAD1500	-	no	Syn. Pile	Ea.	4
Panel Stiles, White	M250200C	M-2502	-	yes	White	Ft.	2
Panel Stiles, Driftwood	M250200D	M-2502	-	yes	Driftwood	Ft.	2
Panel Stiles, Bronze	M250200B	M-2502	-	yes	Bronze	Ft.	2
Optional Rebar for Interlock Stile - Mill	M2516000	M-2516	-	yes	Mill	Ft.	2
Weatherstrip Plug, Injection Moulded, Each Corner	IM355000		-	yes	Black	Ea.	4
#10 x 1" Hex Head SMS, S.S., Panel Assembly	FS002561				SS	Ea.	8
Panel Roller, Tandem, SS, Precision, 1.500, With Spacer	HD300300	SS7143DSPA	-	yes	Steel/Compos	Ea.	2
#8 x 1/2" PFHMSA, Attach Rollers to Bottom Rail	FS003073		-	no	ZI PL ST	Ea.	4
Setting Blocks for Glass - 1/8" x 1" x 1"	MS100090	PSA-1			Black	Ea.	Varies
Backbedding - Pecora 896 610 Trans TBS UV03B	SL000760	Pecora 896 Clr.			Clear	Gal.	Varies
Glass as Required, IG, Impact, NON-Impact						Ea.	1
Glazing Bead, IG, Impact and Non-Impact - White	M250500C	M-2505	-	yes	White	Ft.	2 Hor./2 Vert.
Glazing Bead, IG, Impact and Non-Impact - Driftwood	M250500D	M-2505	-	yes	Driftwood	Ft.	2 Hor./2 Vert.
Glazing Bead, IG, Impact and Non-Impact - Bronze	M250500B	M-2505	-	yes	Bronze	Ft.	2 Hor./2 Vert.
.187 x .160 wstrip for glazing beads	WS10024G				Gray	Ft.	2 hor./2 vert.
Panel Interlock - White	M250300C	M-2503	-	yes	White	Ft.	2
Panel Interlock - Driftwood	M250300D	M-2503	-	yes	Driftwood	Ft.	2
Panel Interlock - Bronze	M250300B	M-2503	-	yes	Bronze	Ft.	2



Report #: 1435.05-106-12

Date: 5/9/2018

By: M. Stremmel

.187 x .250 Weatherstrip for Panel Interlock	WS30060G		-	no	Grey	Ft.	2
Bulb Seal fo Panel Interlock	MS50021L	PPI 0791-1	-	no	Black	Ft.	2
#8 x 7/8" PPHTEK, Attach Interlock to Panel Stile	FS001390		-	no	Mill	Ea.	10
Interlock Screw Cover, Snap-In - White	M-250400C	M-2504	-	yes	White	Ft.	2
Interlock Screw Cover, Snap-In - Adobe	M-250400D	M-2504	-	yes	Driftwood	Ft.	2
Interlock Screw Cover, Snap-In - Bronze	M-250400B	M-2504	-	yes	Bronze	Ft.	2
"OO" Panel							
Panel Top Rail, White	M250000C	M-2500	-	yes	White	Ft.	1
Panel Top Rail, Driftwood	M250000D	M-2500	-	yes	Driftwood	Ft.	1
Panel Top Rail, Bronze	M250000B	M-2500	-	yes	Bronze	Ft.	1
Panel Bottom Rail, White	M250000C	M-2500	-	yes	White	Ft.	1
Panel Bottom Rail, Driftwood	M250000D	M-2500	-	yes	Driftwood	Ft.	1
Panel Bottom Rail, Bronze	M250000B	M-2500	-	yes	Bronze	Ft.	1
.187 x .250 Weatherstrip for top and bottom rails and injection molded filler	WS30060G		-	no	Grey	Ft.	4
.750 tall x 1.250 wide x 1.500 long Adhesive W'Strip Plug, Ends of top/bottom rails	WS40001G	751250GYAD1500	-	no	Syn. Pile	Ea.	4
Panel Stiles, White	M250200C	M-2502	-	yes	White	Ft.	2
Panel Stiles, Driftwood	M250200D	M-2502	-	yes	Driftwood	Ft.	2
Panel Stiles, Bronze	M250200B	M-2502	-	yes	Bronze	Ft.	2
.187 x .250 Weatherstrip for panel Stiles (Frame Jamb Fixed Stile Only)	WS30060G		-	no	Grey	Ft.	2
Optional Rebar for Interlock Stile - Mill	M2516000	M-2516	-	yes	Mill	Ft.	1
Weatherstrip Plug, Injection Moulded, Each Corner	IM355000		-	yes	Black	Ea.	4
#10 x 1" Hex Head SMS, S.S., Panel Assembly	FS002561				SS	Ea.	8
Panel Rollers, Tandem, SS, Precision, 1.500, With Spacer	HD300300	SS7143DSPA	-	yes	eel/Compos	Ea.	2
#8 x 1/2" PFHMSA, Attach Rollers to Bottom Rail	FS003073		-	no	ZI PL ST	Ea.	4
Setting Blocks for Glass - 1/8" x 1" x 1"	MS100090	PSA-1			Black	Ea.	Varies



Molimo[™]
Architectural Product Testing

Report #: 1435.05-106-12

Date: 5/9/2018

By: M. Stremmel

Backbedding - Pecora 896 610 Trans TBS UV03B	SL000760	Pecora 896 Clr.			Clear	Gal.	Varies
Glass as Required, IG, Impact, NON-Impact						Ea.	1
Glazing Bead, IG, Impact and Non-Impact - White	M250500C	M-2505	-	yes	White	Ft.	2 Hor./2 Vert.
Glazing Bead, IG, Impact and Non-Impact - Driftwood	M250500D	M-2505	-	yes	Driftwood	Ft.	2 Hor./2 Vert.
Glazing Bead, IG, Impact and Non-Impact - Bronze	M250500B	M-2505	-	yes	Bronze	Ft.	2 Hor./2 Vert.
.187 x .160 w'strip for glazing beads	WS10024G				Gray	Ft.	2 hor./2 vert.
Standard 144 Ext. Screen (From Rite Screen)							
Latch Screen, 144 Ext. Equipped with the following:							1
856 Front Handle							
857 Back Handle							
478 Stainless Side Adjust Rollers							
Screws #8 x 1/2" Stainless							
Trailing Screen, 144 Ext. Equipped with the following							1
478 Stainless Side Adjust Rollers							
Weatherstrip 45018730/WHWPSR							
Adapter to connect the two screens together							1

	Molimo [™] Architectural Product Testing
Report #:	<u>1435.05-106-12</u>
Date:	<u>5/9/2018</u>
By:	<u>M. Stremmel</u>

Detail "A"
4 x Full

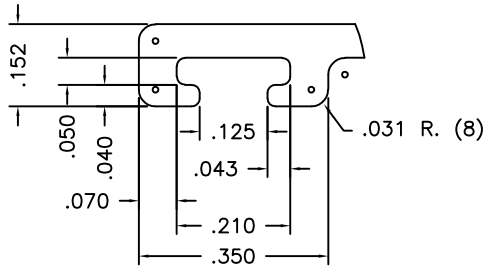

Description	Length	Finish	8-Digit Part #
Panel Top/Bottom Rail	148"	White	M250000C
Panel Top/Bottom Rail	148"	Driftwood	M250000D
Panel Top/Bottom Rail	148"	Bronze	M250000B

Detail "C"
4 x Full

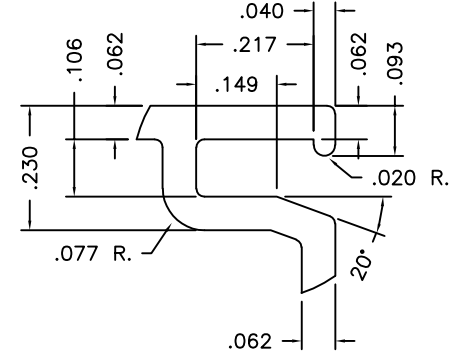

Detail "B"
4 x Full

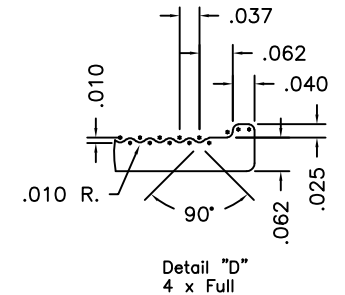
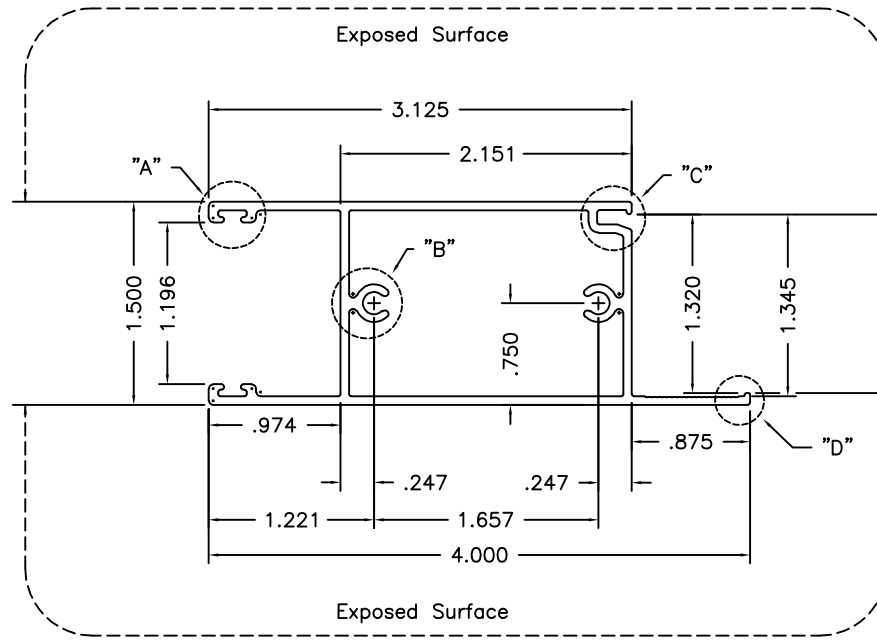
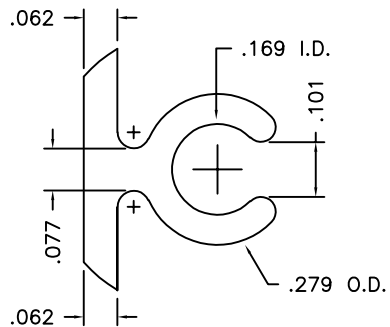

Molimo™
Architectural Product Testing

Report #: 1435.05-106-12

Date: 5/9/2018

By: M. Stremmel

CLASS: Hollow	PAINT PERIMETER: 7.345
THERMAL CAVITY: None	CIRCLE SIZE: 4.500

MATERIAL: 6005-T5	MIWD MI WINDOWS AND DOORS 650 WEST MARKET STREET GRATZ, PA 17030-0370 The information, design or data shown on this document or electronic media is the exclusive property of MI Windows and Doors, LLC. It is considered confidential and proprietary and is made available for limited use only. Its use or reproduction without the expressed written consent of MI Windows and Doors, LLC., is prohibited.
FINISH: Painted	
AREA: .727	
WEIGHT: .873	
PERIMETER: 24.057	UNSPECIFIED WALL: .062 BREAK ALL CORNERS R.015, UNLESS OTHERWISE SPECIFIED

DESCRIPTION: Panel Top Rail Aluminum Extrusion	PRODUCT: 120/130/140 Families	DATE: 06/03/15
SCALE: 1 : 1	PART NUMBER: M-2500	
DFTM: T.C.	DRAWING NUMBER: AE-000029	

-	069A-15	Initial Release For Extrusion Tooling	06/29/15	T.C.
LTR	ECN #	REVISIONS	DATE	BY

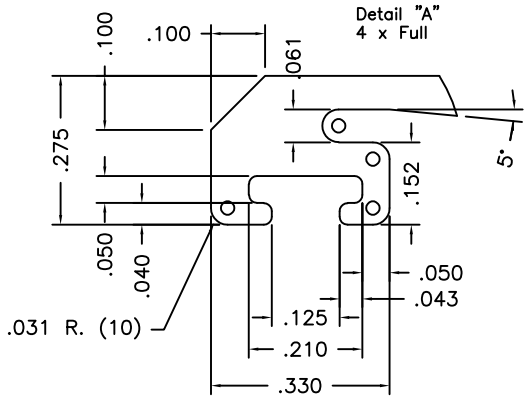

Description	Length	Finish	8-Digit Part #
Panel Stile	192"	White	M250200C
Panel Stile	192"	Driftwood	M250200D
Panel Stile	192"	Bronze	M250200B

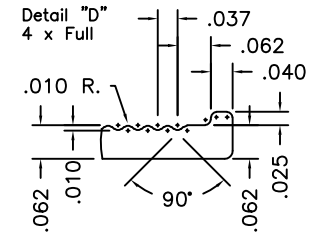
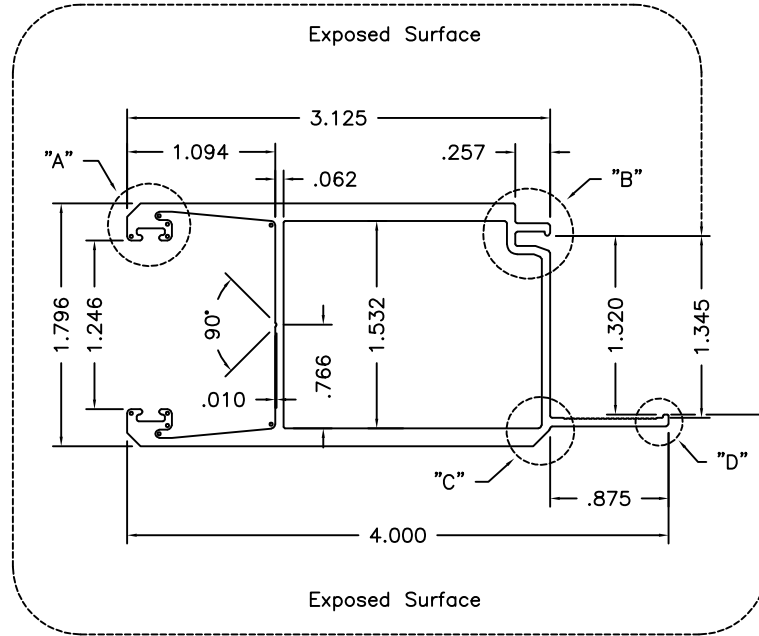
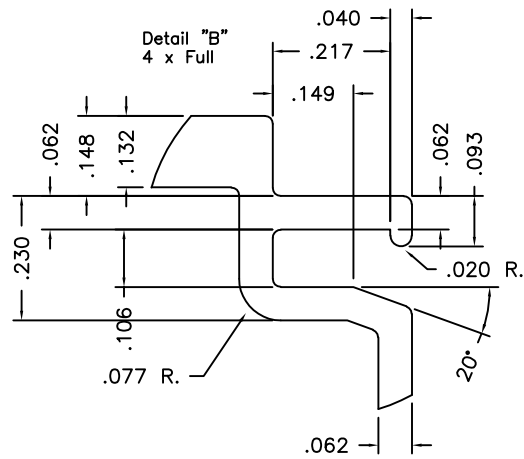
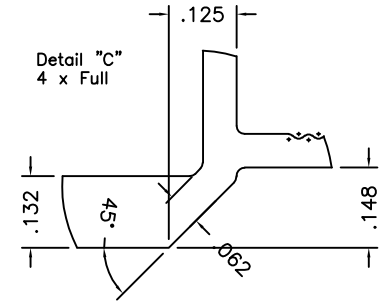

Molimo
Architectural Product Testing

Report #: 1435.05-106-12

Date: 5/9/2018

By: M. Stremmel

CLASS: Hollow	PAIN PERIMETER: 13.042
THERMAL CAVITY: None	CIRCLE SIZE: 4.375

MATERIAL: 6005-T5	MIWD MI WINDOWS AND DOORS 650 WEST MARKET STREET GRATZ, PA 17030-0370 The information, design or data shown on this document or electronic media is the exclusive property of MI Windows and Doors, LLC. It is considered confidential and proprietary and is made available for limited use only. Its use or reproduction without the expressed written consent of MI Windows and Doors, LLC., is prohibited.
FINISH: Painted	
AREA: 1.042	
WEIGHT: 1.250	
PERIMETER: 22.683	UNSPECIFIED WALL: .062 BREAK ALL CORNERS R.015, UNLESS OTHERWISE SPECIFIED

DESCRIPTION: Panel Stiles Aluminum Wxtrusion	DATE: 06/04/15
PRODUCT: 120/130/140 Family	PART NUMBER: M-2502
SCALE: 1 : 1	DRAWING NUMBER: AE-000031
DFTM: T.C.	

LTR	ECN #	REVISIONS	DATE	BY
-	069A-15	Initial Release For Extrusion Tooling	06/29/15	T.C.

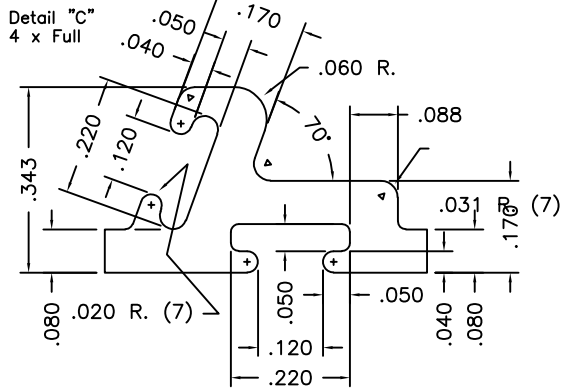

Description	Length	Finish	8-Digit Part #
Panel Interlock	192"	White	M250300C
Panel Interlock	192"	Driftwood	M250300D
Panel Interlock	192"	Bronze	M250300B

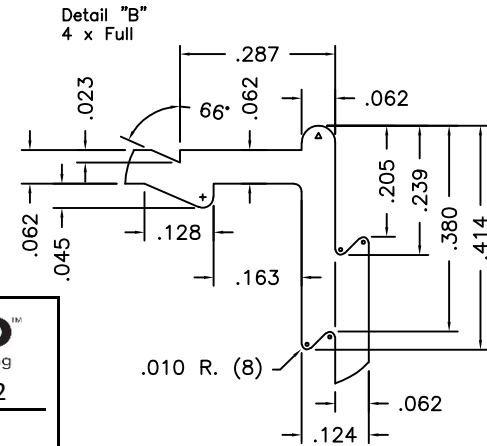
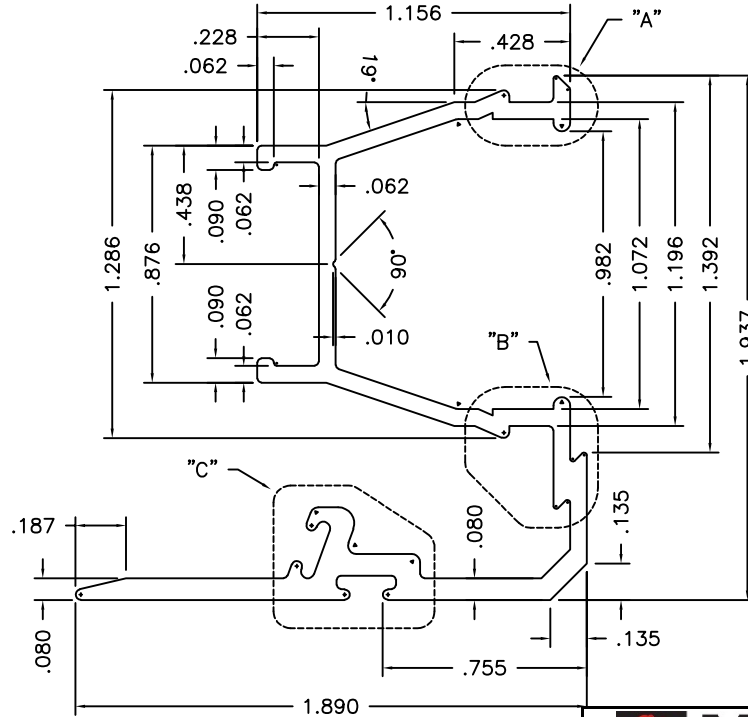
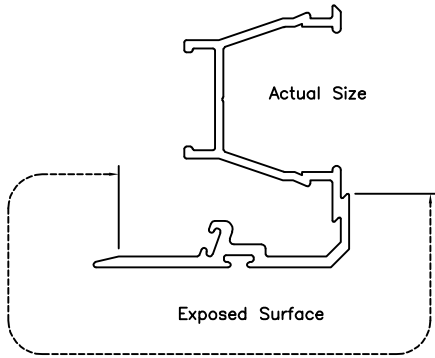
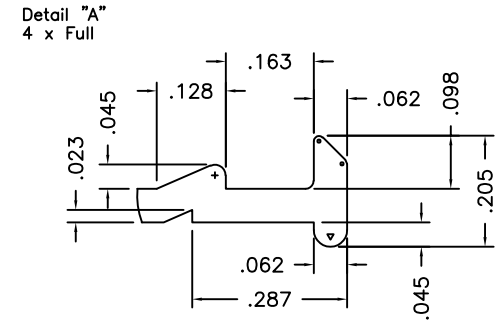

Report #: 1435.05-106-12

Date: 5/9/2018

By: M. Stremmel

CLASS: Solid	PAINT PERIMETER: 2.859
THERMAL CAVITY: None	CIRCLE SIZE: 3"

MATERIAL: 6005-T5

FINISH: Painted

UNSPECIFIED WALL: .062

AREA: .442

WEIGHT: .531

PERIMETER: 12.828

BREAK ALL CORNERS R.015, UNLESS OTHERWISE SPECIFIED

MIWD MI WINDOWS AND DOORS
650 WEST MARKET STREET GRATZ, PA 17030-0370

The information, design or data shown on this document or electronic media is the exclusive property of MI Windows and Doors, LLC. It is considered confidential and proprietary and is made available for limited use only. Its use or reproduction without the expressed written consent of MI Windows and Doors, LLC., is prohibited.

DESCRIPTION: Panel Interlock
Aluminum Extrusion

PRODUCT: 120/130/140 Families

DATE: 06/04/15

SCALE: 2 : 1

PART NUMBER: M-2503

DFTM: T.C.

DRAWING NUMBER: AE-000032

LTR	ECN #	REVISIONS	DATE	BY	T.C.
-	069A-15	Initial Release For Extrusion Tooling	06/29/15	T.C.	

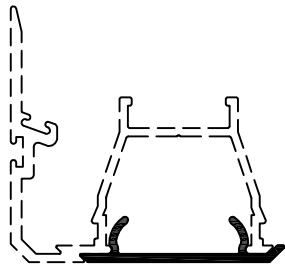
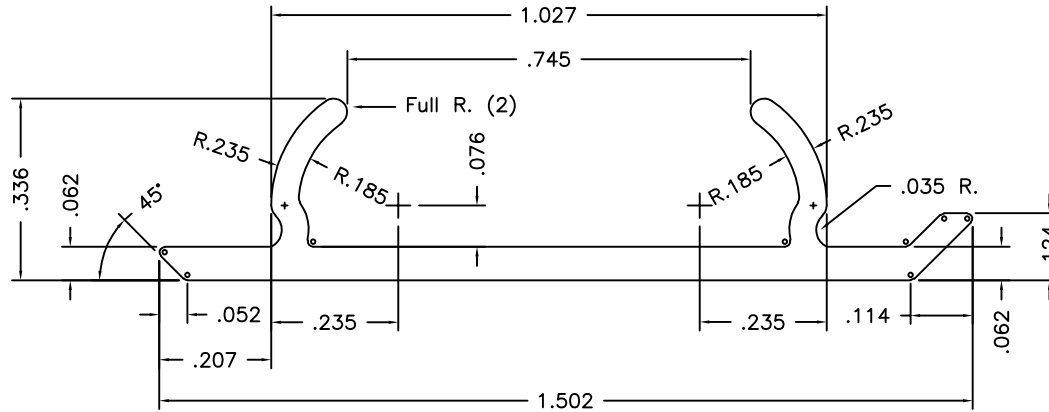
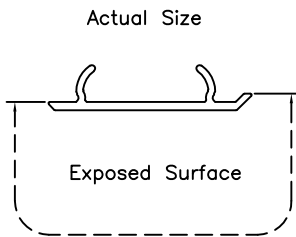

Molimo™
Architectural Product Testing

Report #: 1435.05-106-12

Date: 5/9/2018

By: M. Stremmel

Description	Length	Finish	8-Digit Part #
Interlock Cover	192"	White	M250400C
Interlock Cover	192"	Driftwood	M250400D
Interlock Cover	192"	Bronze	M250400B

CLASS: Solid	PAINT PERIMETER: 1.606
THERMAL CAVITY: None	CIRCLE SIZE: 1 3/4"

MATERIAL: 6005-T5
FINISH: Painted
AREA: .122
WEIGHT: .147
PERIMETER: 4.280

MIWD MI WINDOWS AND DOORS
650 WEST MARKET STREET GRATZ, PA 17030-0370

The information, design or data shown on this document or electronic media is the exclusive property of MI Windows and Doors, LLC. It is considered confidential and proprietary and is made available for limited use only. Its use or reproduction without the expressed written consent of MI Windows and Doors, LLC., is prohibited.

DESCRIPTION: Interlock Cover Aluminum Extrusion	PRODUCT: 120/130/140 Families	DATE: 06/04/15
SCALE: 4 : 1	PART NUMBER: M-2504	
DFTM: T.C.	DRAWING NUMBER: AE-000033	

-	069A-15	Initial Release For Extrusion Tooling	06/29/15	T.C.
LTR	ECN #	REVISIONS	DATE	BY

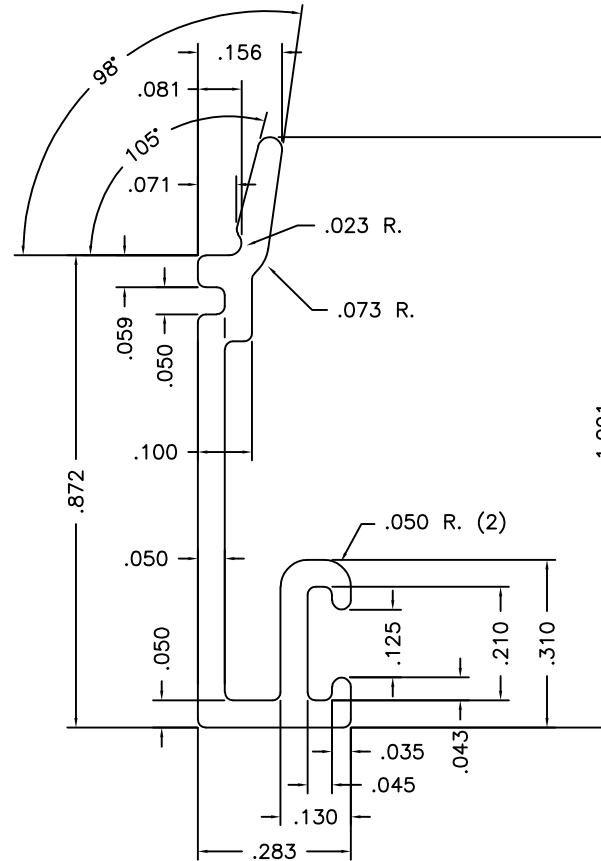
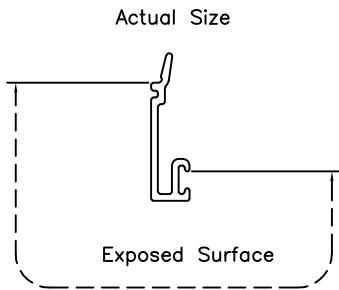

Description	Length	Finish	8-Digit Part #
I.G. Bead, Impact and Non-Impact	180"	White	M250500C
I.G. Bead, Impact and Non-Impact	180"	Driftwood	M250500D
I.G. Bead, Impact and Non-Impact	180"	Bronze	M250500B

Report #: 1435.05-106-12

Date: 5/9/2018

By: M. Stremmel

CLASS: Solid	PAIN PERIMETER: 1.707
THERMAL CAVITY: None	CIRCLE SIZE: 1.250



MATERIAL: 6063-T5
FINISH: Painted
AREA: .092
WEIGHT: .110
PERIMETER: 3.643

MIWD MI WINDOWS AND DOORS
 650 WEST MARKET STREET GRATZ, PA 17030-0370

The information, design or data shown on this document or electronic media is the exclusive property of MI Windows and Doors, LLC. It is considered confidential and proprietary and is made available for limited use only. Its use or reproduction without the expressed written consent of MI Windows and Doors, LLC., is prohibited.

DESCRIPTION: IG Glazing Bead Aluminum Extrusion	
PRODUCT: 120/130/140 Families	DATE: 06/04/15
SCALE: 4 : 1	PART NUMBER: M-2505
DFTM: T.C.	DRAWING NUMBER: AE-000034

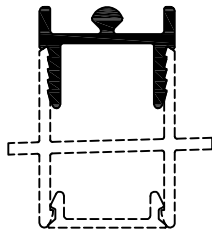
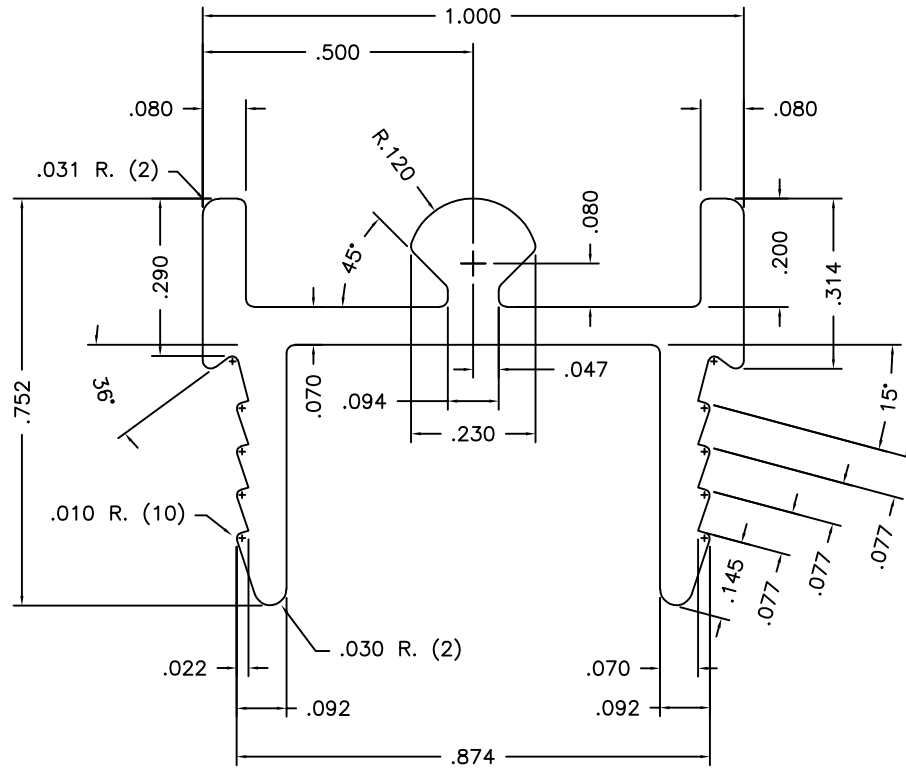
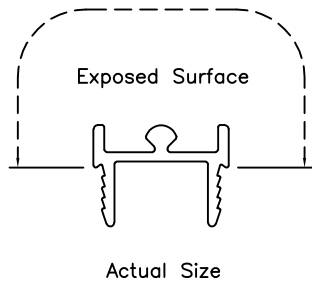
LTR	ECN #	REVISIONS	DATE	BY
-	069A-15	Initial Release For Extrusion Tooling	06/29/15	T.C.

Molimo[™]
Architectural Product Testing

Report #: 1435.05-106-12

Date: 5/9/2018

By: M. Stremmel

Description	Length	Finish	8-Digit Part #
Roller Track	180"	Mill	M2511000

CLASS: Solid	PAIN PERIMETER: None
THERMAL CAVITY: None	CIRCLE SIZE: 1.250

MATERIAL: 6063-T5	MIWD MI WINDOWS AND DOORS 650 WEST MARKET STREET GRATZ, PA 17030-0370 The information, design or data shown on this document or electronic media is the exclusive property of MI Windows and Doors, LLC. It is considered confidential and proprietary and is made available for limited use only. Its use or reproduction without the expressed written consent of MI Windows and Doors, LLC., is prohibited.
FINISH: Mill	
AREA: .214	
WEIGHT: .256	
PERIMETER: 5.368	

DESCRIPTION: Frame Sill Snap-In Roller Track Aluminum Extrusion	
PRODUCT: 120/130/140 Families	DATE: 06/04/15
SCALE: 4 : 1	PART NUMBER: M-2511
DFTM: T.C.	DRAWING NUMBER: AE-000040

LTR	ECN #	REVISIONS	DATE	BY
-	069B-15	Initial release for extrusion tooling	07/08/15	T.C.

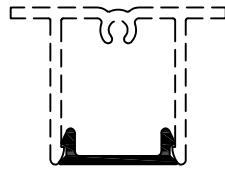

Actual Size

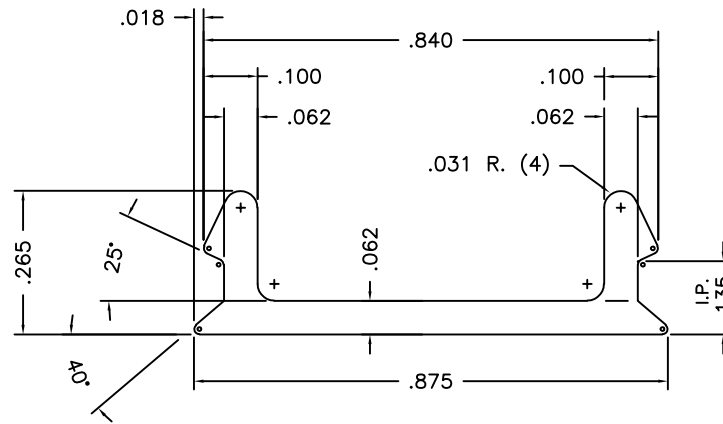
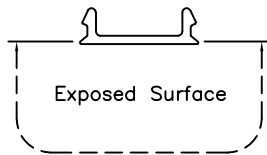

Molimo
Architectural Product Testing

Report #: 1435.05-106-12

Date: 5/9/2018

By: M. Stremmel

Description	Length	Finish	8-Digit Part #
Filler	180"	White	M251200C
Filler	180"	Driftwood	M251200D
Filler	180"	Bronze	M251200B

CLASS: Solid	PAINT PERIMETER: .904
THERMAL CAVITY: None	CIRCLE SIZE: 1.000

MATERIAL: 6063-T5
FINISH: Painted
AREA: .081
WEIGHT: .097
PERIMETER: 2.597

MIWD MI WINDOWS AND DOORS
650 WEST MARKET STREET GRATZ, PA 17030-0370

The information, design or data shown on this document or electronic media is the exclusive property of MI Windows and Doors, LLC. It is considered confidential and proprietary and is made available for limited use only. Its use or reproduction without the expressed written consent of MI Windows and Doors, LLC., is prohibited.

DESCRIPTION: Frame Head/Jamb Filler Aluminum Extrusion	
PRODUCT: 120/130/140 Families	DATE: 06/05/15
SCALE: 4 : 1	PART NUMBER: M-2512
DFTM: T.C.	DRAWING NUMBER: AE-000041

-	069B-15	Initial release for extrusion tooling	07/08/15	T.C.	
LTR	ECN #	REVISIONS	DATE	BY	

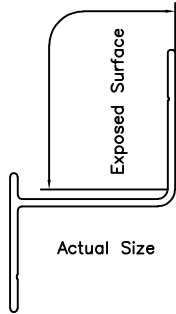

Description	Length	Finish	8-Digit Part #
Panel Retainer	144"	White	M251900C
Panel Retainer	144"	Driftwood	M251900D
Panel Retainer	144"	Bronze	M251900B

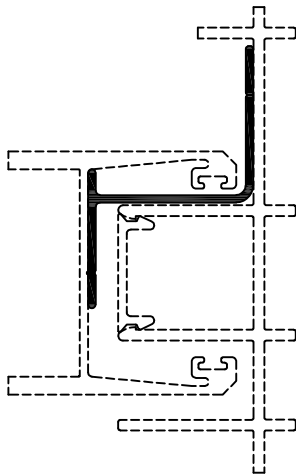

Molimo™
Architectural Product Testing

Report #: 1435.05-106-12

Date: 5/9/2018

By: M. Stremmel

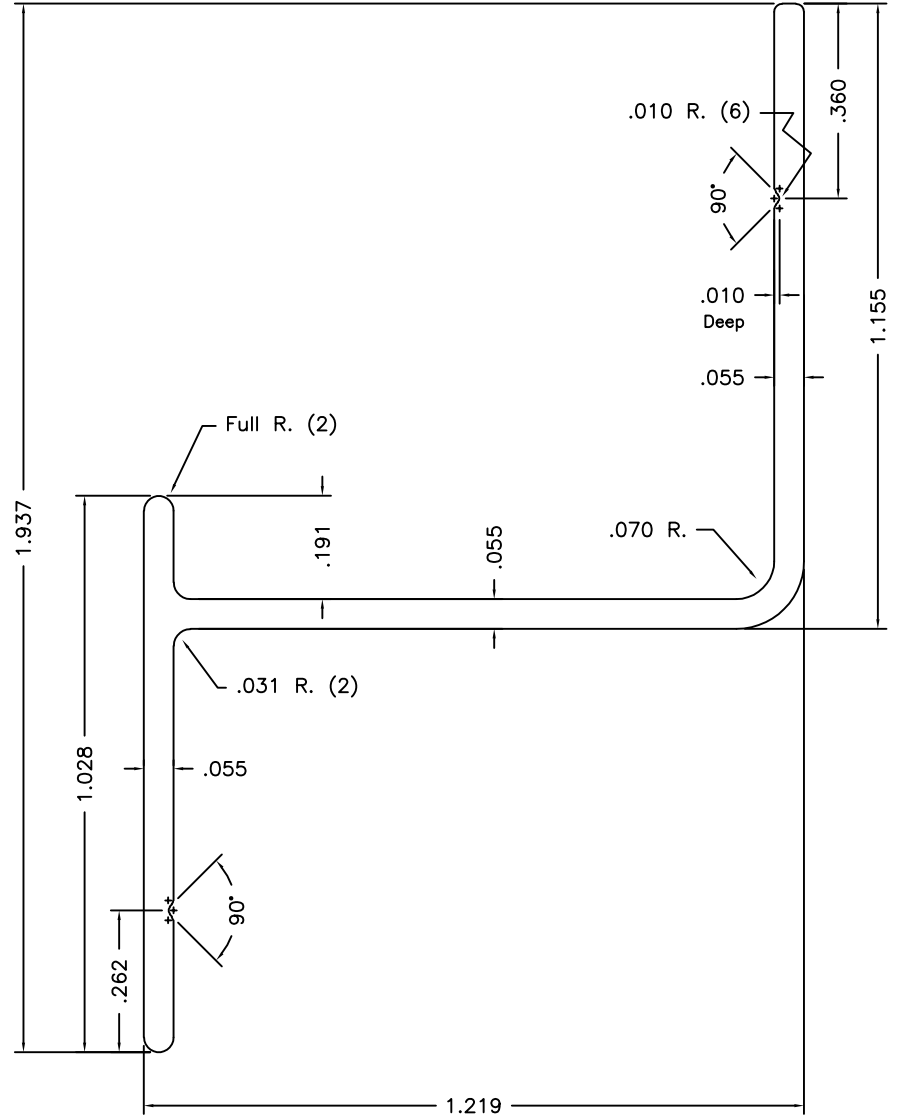

CLASS: Solid	PAIN PERIMETER: 1.094
THERMAL CAVITY: None	CIRCLE SIZE: 2.500

MATERIAL: 6063-T5
FINISH: Painted
AREA: .178
WEIGHT: .214
PERIMETER: 6.537

MIWD MI WINDOWS AND DOORS
650 WEST MARKET STREET GRATZ, PA 17030-0370

The information, design or data shown on this document or electronic media is the exclusive property of MI Windows and Doors, LLC. It is considered confidential and proprietary and is made available for limited use only. Its use or reproduction without the expressed written consent of MI Windows and Doors, LLC., is prohibited.

DESCRIPTION: Fixed Panel Stile Retainer Aluminum Extrusion	
PRODUCT: XXXX	DATE: 06/05/15
SCALE: 4 : 1	PART NUMBER: M-2519
DFTM: T.C.	DRAWING NUMBER: AE-000048

LTR	ECN #	REVISIONS	DATE	BY	T.C.
-	069B-15	Initial Release For Extrusion Tooling	07/09/15	T.C.	

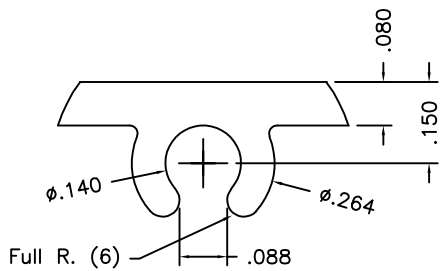

Detail "A"
4 x Full

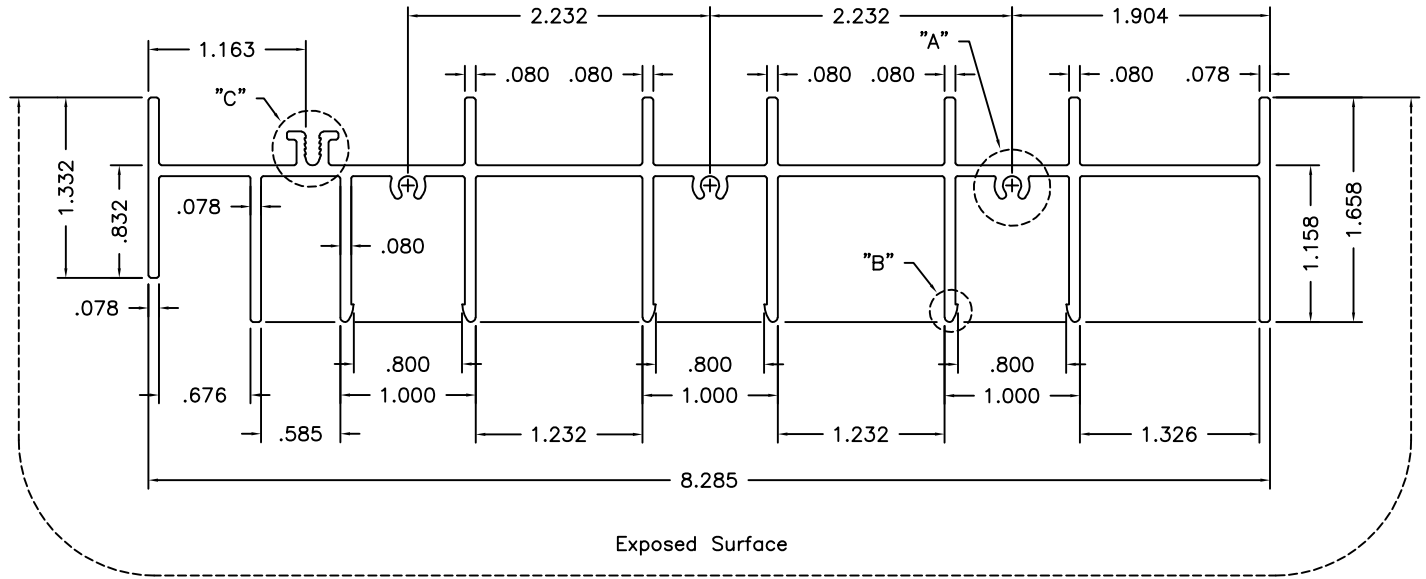

Exposed Surface

Description	Length	Finish	8-Digit Part #
Frame Head	180"	White	M252000C
Frame Head	180"	Driftwood	M252000D
Frame Head	180"	Bronze	M252000B

MolimoTM
Architectural Product Testing

Report #: 1435.05-106-12

Date: 5/9/2018

By: M. Stremmel

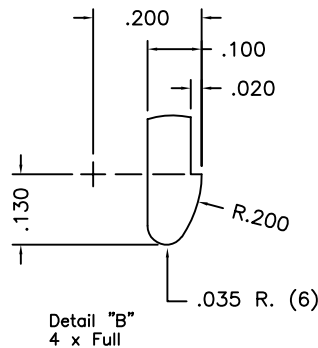

Detail "B"
4 x Full

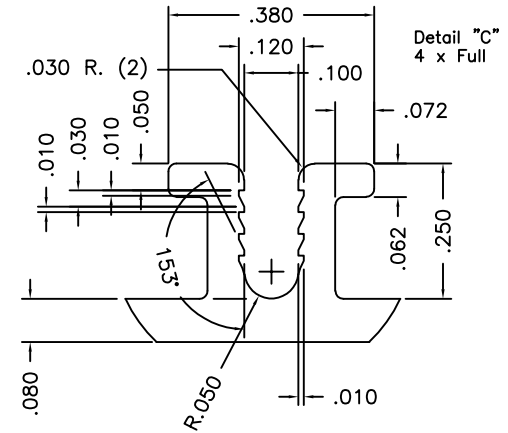

Detail "C"
4 x Full

CLASS: Solid	PAINT PERIMETER: 29.812
THERMAL CAVITY: None	CIRCLE SIZE: 8.500

				MATERIAL: 6005-T5		 <small>650 WEST MARKET STREET GRATZ, PA 17030-0370</small>		DESCRIPTION: Frame Head, 3-Track, Finless Aluminum Extrusion	
				FINISH: Painted				UNSPECIFIED WALL: .080	
				AREA: 1.798		The information, design or data shown on this document or electronic media is the exclusive property of MI Windows and Doors, LLC. It is considered confidential and proprietary and is made available for limited use only. Its use or reproduction without the expressed written consent of MI Windows and Doors, LLC., is prohibited.		DATE: 06/08/15	
				WEIGHT: 2.158				SCALE: 1 : 1	
				PERIMETER: 45.180		BREAK ALL CORNERS R.015, UNLESS OTHERWISE SPECIFIED		DFTM: T.C.	
- 113A-16		Initial release for extrusion tooling		08/08/16		T.C.		DRAWING NUMBER: AE-000049	
LTR		ECN #		REVISIONS		DATE		BY	

Detail "A"
4 x Full

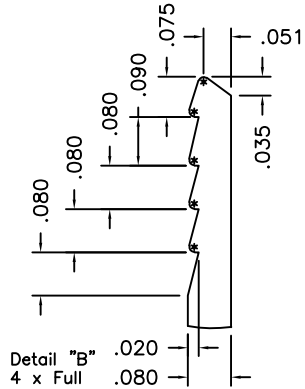
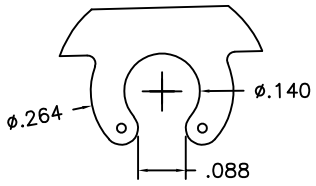

Detail "B"
4 x Full

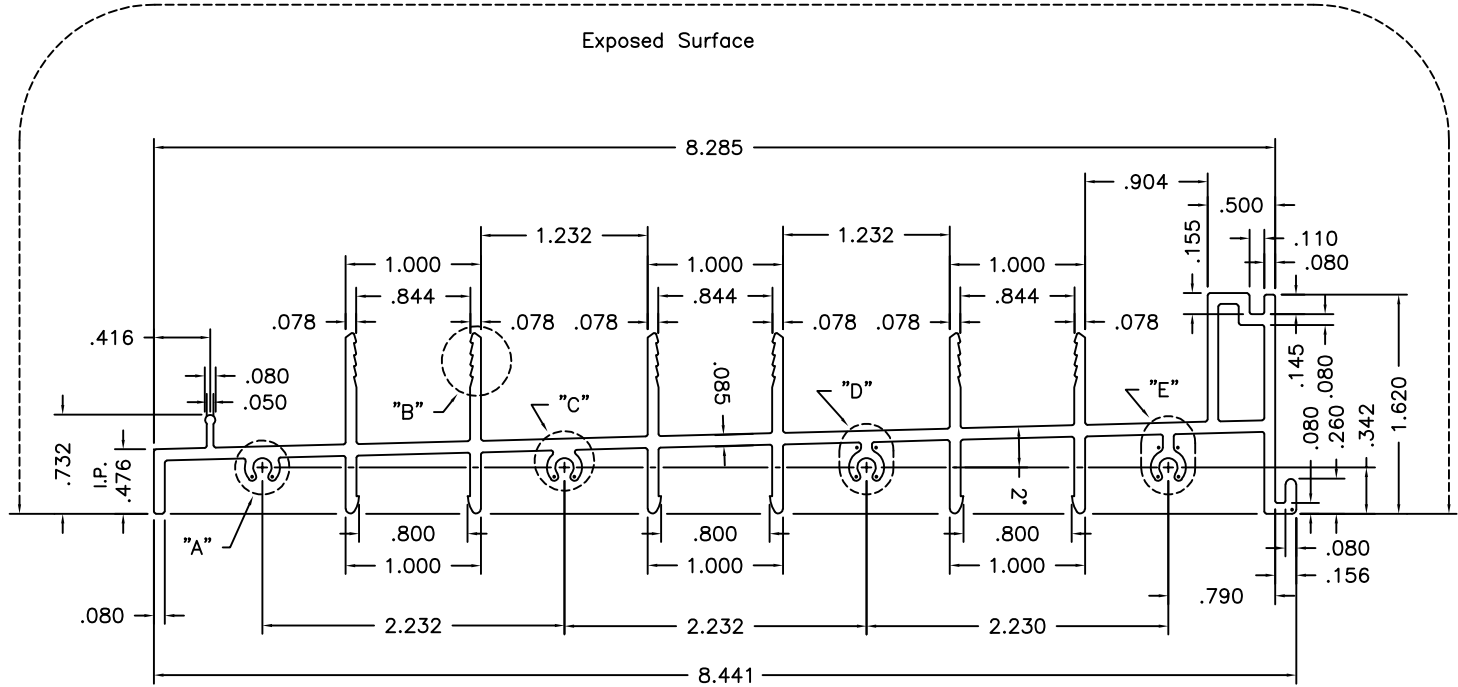

Detail "C"
4 x Full

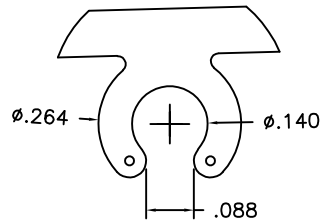

Detail "D"
4 x Full

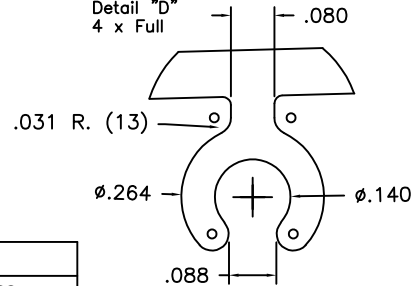

Detail "E"
4 x Full

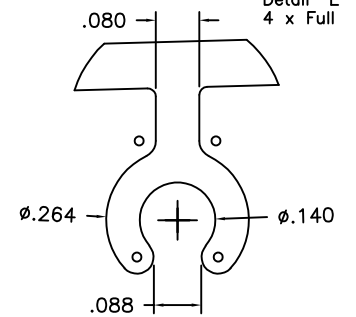

Description	Length	Finish	8-Digit Part #
Frame Sill	180"	Mill	M2522000

Molimo
Architectural Product Testing

Report #: 1435.05-106-12

Date: 5/9/2018

By: M. Stremmel

CLASS: Hollow	PAIN PERIMETER:
THERMAL CAVITY: None	CIRCLE SIZE: 8.500

MATERIAL: 6005-T5	UNSPECIFIED WALL: .080
FINISH: Mill	
AREA: 1.721	
WEIGHT: 2.065	
PERIMETER: 42.875	BREAK ALL CORNERS R.015, UNLESS OTHERWISE SPECIFIED

MIWD MI WINDOWS AND DOORS
650 WEST MARKET STREET GRATZ, PA 17030-0370

The information, design or data shown on this document or electronic media is the exclusive property of MI Windows and Doors, LLC. It is considered confidential and proprietary and is made available for limited use only. Its use or reproduction without the expressed written consent of MI Windows and Doors, LLC., is prohibited.

DESCRIPTION: Frame Sill, 3-Track Aluminum Extrusion	
PRODUCT: 130/130P Families	DATE: 06/08/15
SCALE: 1 : 1	PART NUMBER: M-2522
DFTM: T.C.	DRAWING NUMBER: AE-000051

LTR	ECN #	REVISIONS	DATE	BY	T.C.
-	113A-16	Initial release for extrusion tooling	08/08/16		

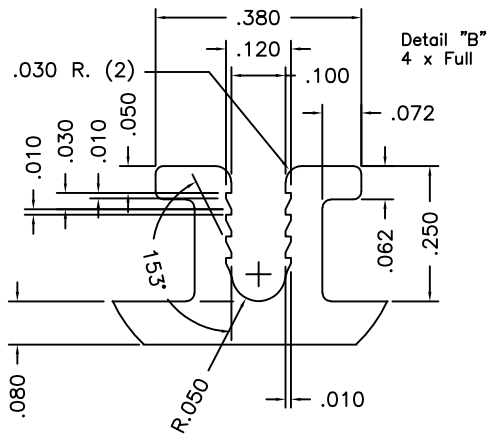
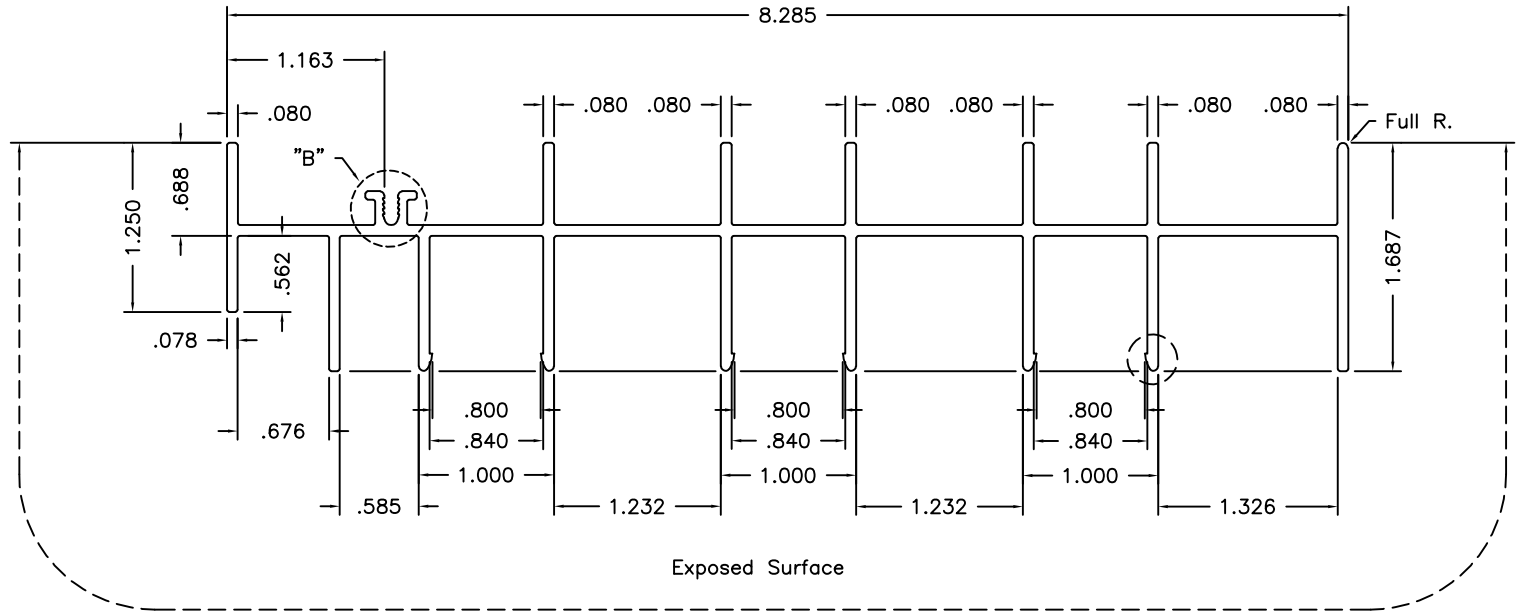

Description	Length	Finish	8-Digit Part #
Frame Jamb	180"	White	M252300C
Frame Jamb	180"	Driftwood	M252300D
Frame Jamb	180"	Bronze	M252300B

Molimo™
Architectural Product Testing

Report #: 1435.05-106-12

Date: 5/9/2018

By: M. Stremmel

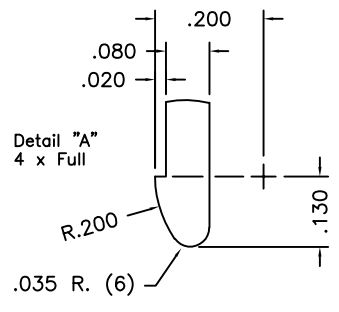

CLASS: Solid	PAINT PERIMETER: 26.583
THERMAL CAVITY: None	CIRCLE SIZE: 8.500

				MATERIAL: 6005-T5		MIWD MI WINDOWS AND DOORS 650 WEST MARKET STREET GRATZ, PA 17030-0370		DESCRIPTION: Frame Jamb, 3-Track, Finless Aluminum Extrusion	
				FINISH: Painted		UNSPECIFIED WALL: .080		PRODUCT: 130/130P Families	
				AREA: 1.726		BREAK ALL CORNERS R.015, UNLESS OTHERWISE SPECIFIED		DATE: 06/08/15	
				WEIGHT: 2.072				SCALE: 1 : 1	
				PERIMETER: 43.205		The information, design or data shown on this document or electronic media is the exclusive property of MI Windows and Doors, LLC. It is considered confidential and proprietary and is made available for limited use only. Its use or reproduction without the expressed written consent of MI Windows and Doors, LLC., is prohibited.		DFTM: T.C.	
- 113A-16		Initial release for extrusion tooling		08/08/16		T.C.		DRAWING NUMBER: AE-000052	
LTR	ECN #	REVISIONS		DATE	BY				

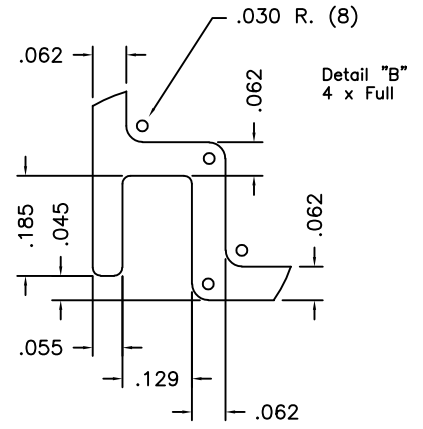
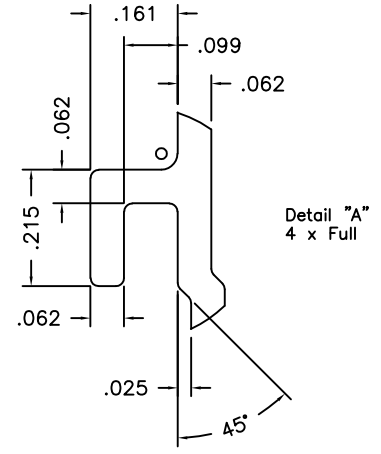
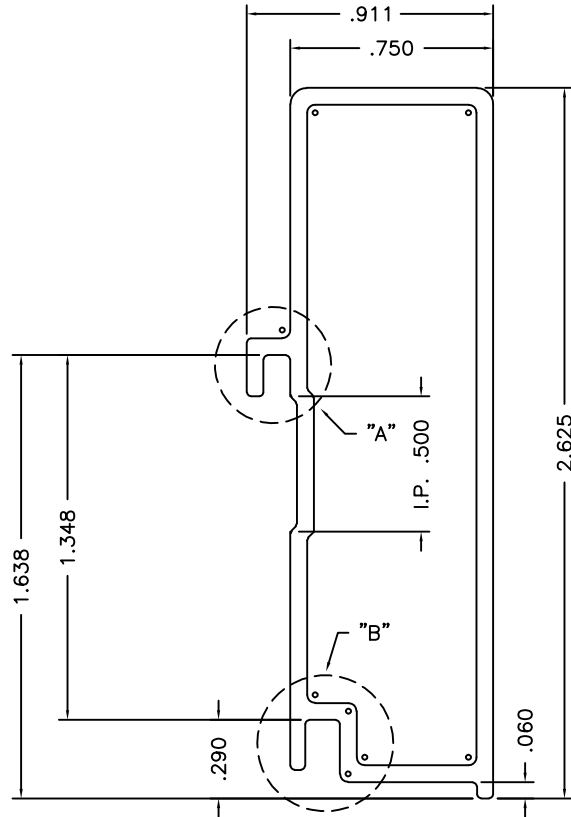
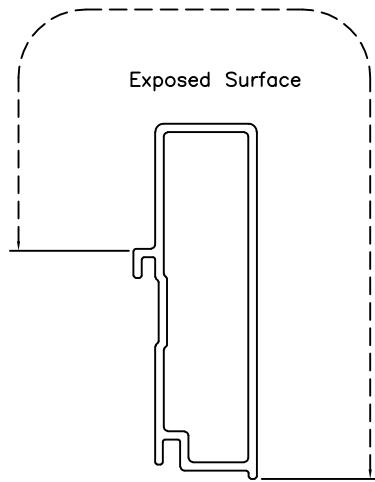

Description	Length	Finish	8-Digit Part #
Sill Extender	196"	Mill	M2530000

Report #: 1435.05-106-12
 Date: 5/9/2018
 By: M. Stremmel

CLASS: Hollow	PAINT PERIMETER: None
THERMAL CAVITY: None	CIRCLE SIZE: 2.750

				MATERIAL: 6063-T5		MIWD MI WINDOWS AND DOORS 650 WEST MARKET STREET GRATZ, PA 17030-0370		DESCRIPTION: Frame Sill Extender, 2.625 Aluminum Extrusion			
				FINISH: Mill				UNSPECIFIED WALL: .062		PRODUCT: 120/130/140 Families	
				AREA: .429		The information, design or data shown on this document or electronic media is the exclusive property of MI Windows and Doors, LLC. It is considered confidential and proprietary and is made available for limited use only. Its use or reproduction without the expressed written consent of MI Windows and Doors, LLC., is prohibited.		DATE: 06/09/15			
				WEIGHT: .515				SCALE: 2 : 1		PART NUMBER: M-2530	
				PERIMETER: 13.687				DFTM: T.C.		DRAWING NUMBER: AE-000059	
-		069B-15		Initial release for extrusion tooling		07/09/15		T.C.			
LTR		ECN #		REVISIONS		DATE		BY			

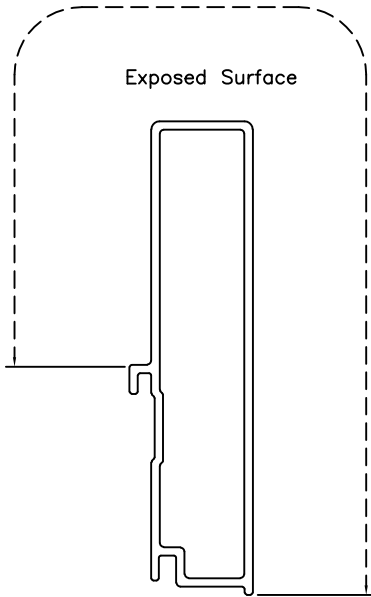

Description	Length	Finish	8-Digit Part #
Sill Extender	196"	Mill	M2531000

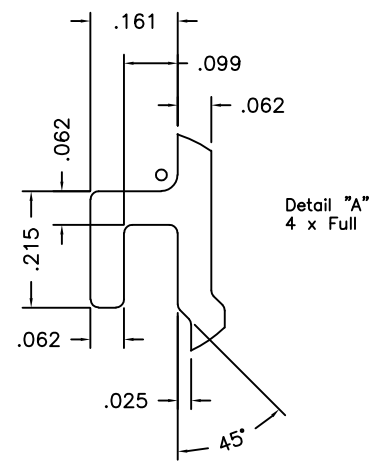
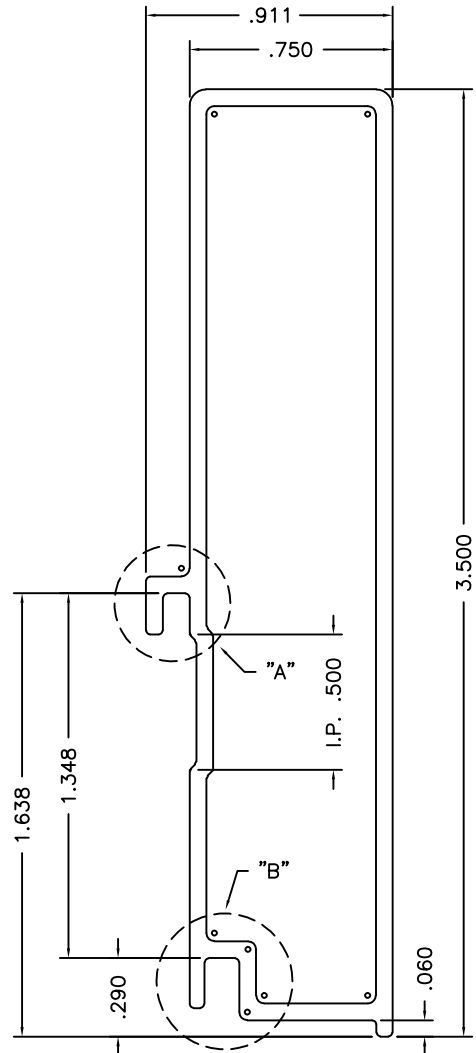

Molimo™
Architectural Product Testing

Report #: 1435.05-106-12

Date: 5/9/2018

By: M. Stremmel

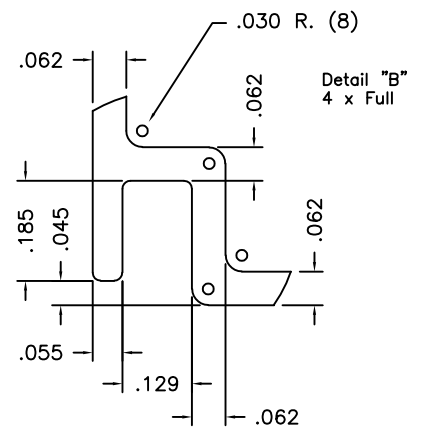

CLASS: Hollow	PAINT PERIMETER: None
THERMAL CAVITY: None	CIRCLE SIZE: 3.625

				MATERIAL: 6063-T5		MIWD MI WINDOWS AND DOORS 650 WEST MARKET STREET GRATZ, PA 17030-0370		DESCRIPTION: Frame Sill Extender, 3.500 Aluminum Extrusion	
				FINISH: Mill	UNSPECIFIED WALL: .062			PRODUCT: 120/130/140 Families	
				AREA: .530	BREAK ALL CORNERS R.015, UNLESS OTHERWISE SPECIFIED		SCALE: 2 : 1		PART NUMBER: M-2531
				WEIGHT: .636			The information, design or data shown on this document or electronic media is the exclusive property of MI Windows and Doors, LLC. It is considered confidential and proprietary and is made available for limited use only. Its use or reproduction without the expressed written consent of MI Windows and Doors, LLC., is prohibited.		DFTM: T.C.
-	069B-15	Initial release for extrusion tooling	07/09/15	T.C.	PERIMETER: 16.939				
LTR	ECN #	REVISIONS	DATE	BY					

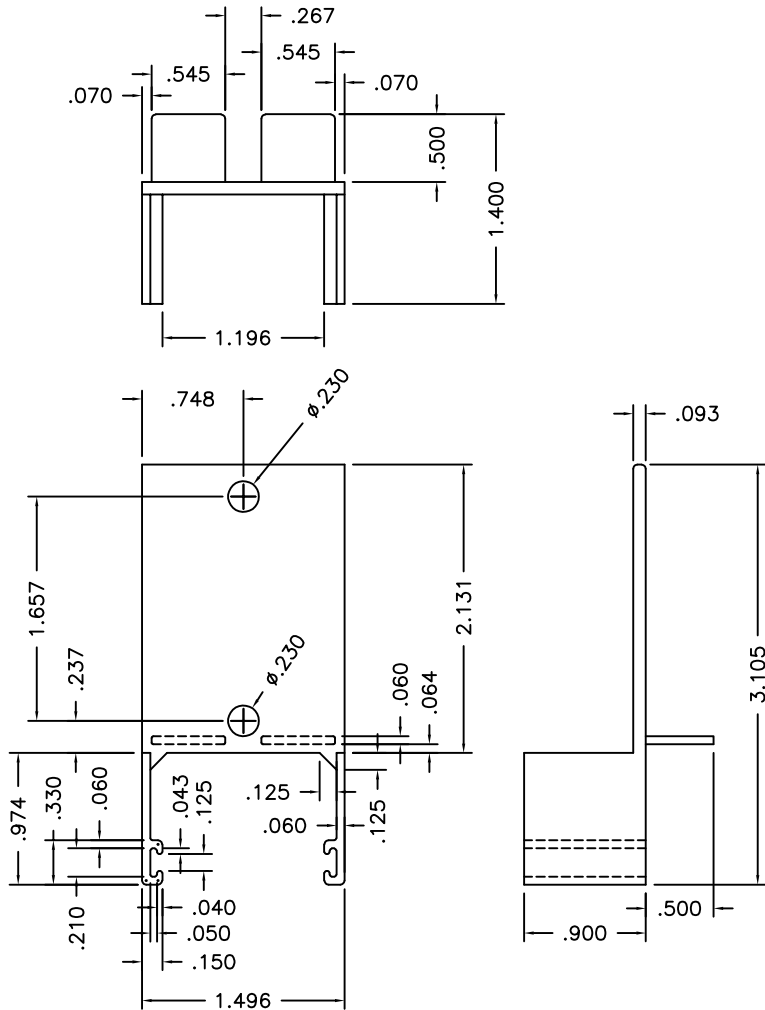

Supplier: M&M Plastics

Report #: 1435.05-106-12
 Date: 5/9/2018
 By: M. Stremmel

					MATERIAL: Nylon	<p>The information, design or data shown on this document or electronic media is the exclusive property of MI Windows and Doors, LLC. It is considered confidential and proprietary and is made available for limited use only. Its use or reproduction without the expressed written consent of MI Windows and Doors, LLC., is prohibited.</p>	DESCRIPTION: Injection Moulded Part Weatherstrip Plug		
					FINISH: Black		UNSPECIFIED WALL:	PRODUCT: 120/130/140 Families	DATE: 07/21/15
					AREA:		BREAK ALL CORNERS R.015, UNLESS OTHERWISE SPECIFIED	SCALE: Full	PART NUMBER: IM355000
					WEIGHT:			DFTM: T.C.	DRAWING NUMBER: HW-000056
					PERIMETER:				
LTR	ECN #		REVISIONS	DATE	BY				



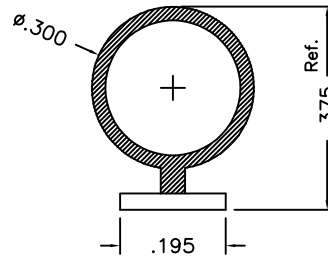

Actual Size



Vendor: Amesbury Truth

Note: All dimensions taken from sample part.

	Molimo TM Architectural Product Testing
Report #:	1435.05-106-12
Date:	5/9/2018
By:	M. Stremmel

					MATERIAL:	 MI MI WINDOWS AND DOORS, LLC. 650 WEST MARKET STREET GRATZ, PA 17030-0370	DESCRIPTION: Bulb Seal Panel Interlock			
					FINISH:		UNSPECIFIED WALL:	PRODUCT: 120/120P/130/130P/140/140P	DATE: 08/16/16	
					AREA:		BREAK ALL CORNERS R.015, UNLESS OTHERWISE SPECIFIED	The information, design or data shown on this document or electronic media is the exclusive property of MI Windows and Doors, LLC. It is considered confidential and proprietary and is made available for limited use only. Its use or reproduction without the expressed written consent of MI Windows and Doors, LLC., is prohibited.		
					WEIGHT:			SCALE: 4 : 1	PART NUMBER: MS50021L	
					PERIMETER:			DFTM: T.C.	DRAWING NUMBER: HW-000057	
LTR	ECN #	REVISIONS	DATE	BY						

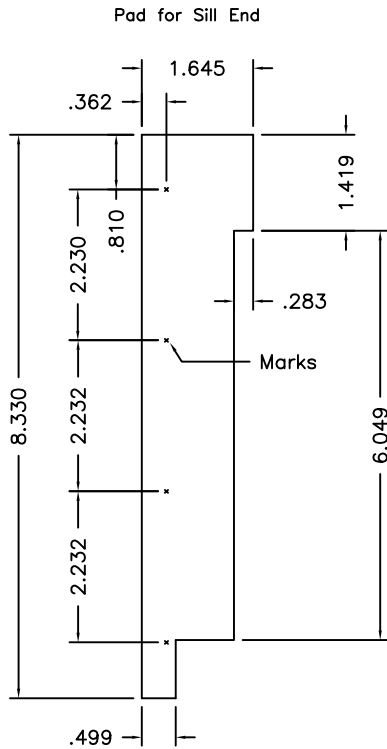

Material:
 $\frac{1}{32}$ " thick foam with $\frac{1}{16}$ " Butyl

Colors:
 LH & RH White foam with gray butyl MS50050C
 LH & RH Black foam with black butyl MS50050L

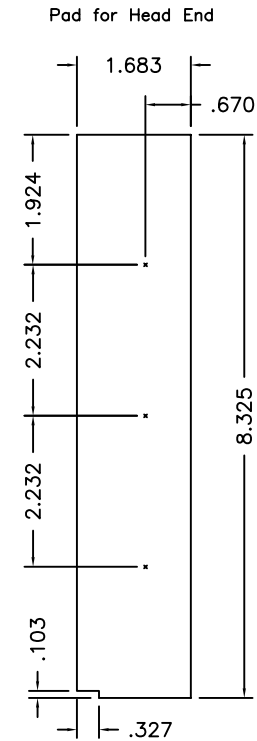

Material:
 $\frac{1}{32}$ " thick foam with $\frac{1}{16}$ " Butyl

Colors:
 LH & RH White foam with gray butyl MS50051C
 LH & RH Black foam with black butyl MS50051L



MolimoTM
 Architectural Product Testing

Report #: 1435.05-106-12

Date: 5/9/2018

By: M. Stremmel

					MATERIAL: Foam/Nutyl	 <p>650 WEST MARKET STREET GRATZ, PA 17030-0370</p> <p>The information, design or data shown on this document or electronic media is the exclusive property of MI Windows and Doors, LLC. It is considered confidential and proprietary and is made available for limited use only. Its use or reproduction without the expressed written consent of MI Windows and Doors, LLC., is prohibited.</p>	DESCRIPTION: Frame Corner Gaskets		
					FINISH: White/Black UNSPECIFIED WALL:		Secon		
					AREA:		PRODUCT: 130/130P	DATE: 07/21/15	
					WEIGHT:		SCALE: Half	PART NUMBER: MS50050C,L	
A	None	Part numbers updated to show sets	05/10/17	T.C.	BREAK ALL CORNERS R.015, UNLESS OTHERWISE SPECIFIED	DFTM: T.C.	DRAWING NUMBER: HW-000059		
LTR	ECN #	REVISIONS	DATE	BY	PERIMETER:				

Supplier:
M&M Plastics
15800 NW 15th Ave.
Miami Fl. 33169

Rep:
Bill Walker
Sullivan & Associates



Report #: 1435.05-106-12
Date: 5/9/2018
By: M. Stremmel

MI 8-Digit Part Numbers:
IM20800C, White
IM20800B, Bronze
IM20800D, Driftwood

Base

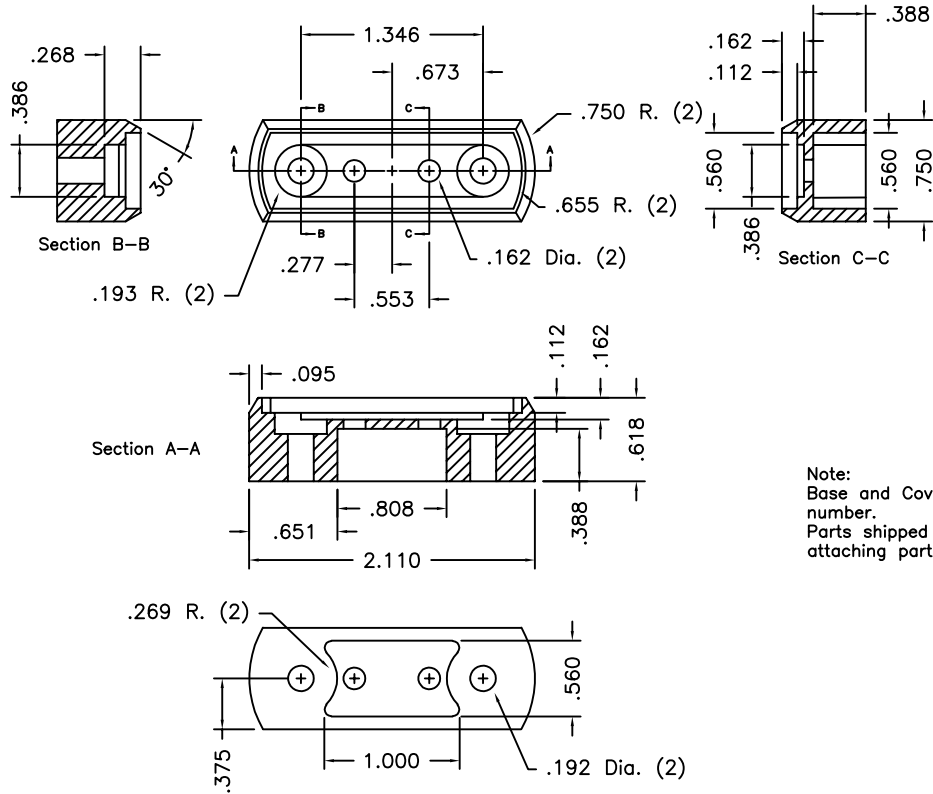

Cover

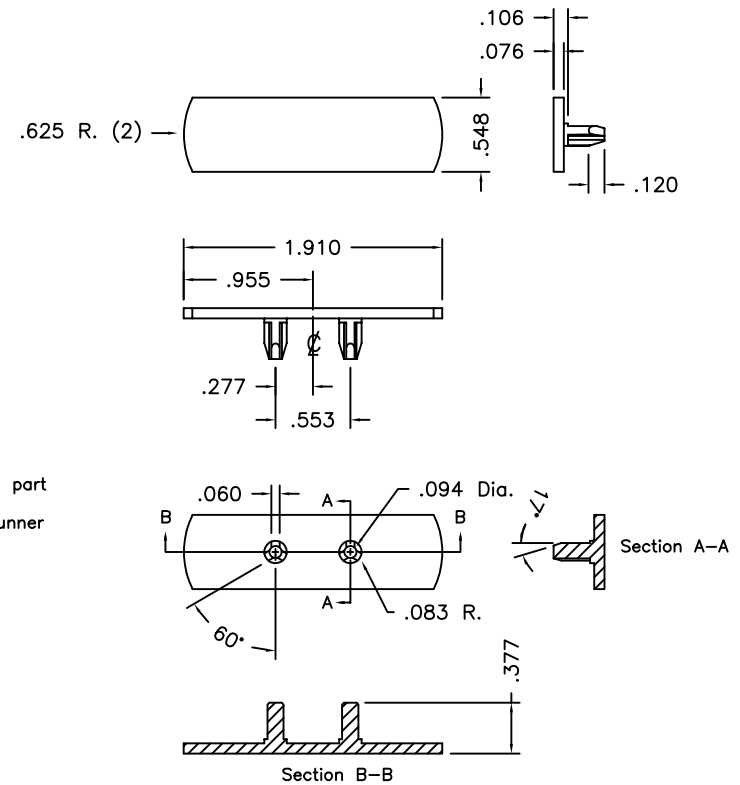

Note:
Base and Cover supplied under one part number.
Parts shipped together with mold runner attaching parts together.

				MATERIAL: Nylon		 MI WINDOWS AND DOORS, LLC. 650 WEST MARKET STREET GRATZ, PA 17030-0370		DESCRIPTION: Bump Stop Base and Cover Injection Molded		
				FINISH: Wh, Bz, Dw UNSPECIFIED WALL:				PRODUCT: 120/120P/130/130P/140/140P		DATE: 04/05/17
				AREA:				SCALE: 1 : 1		PART NUMBER: IM20800C, B, D
				WEIGHT:				DFTM: T.C.		DRAWING NUMBER: HW-000068
				PERIMETER:						
LTR	ECN #	REVISIONS	DATE	BY	BREAK ALL CORNERS R.015, UNLESS OTHERWISE SPECIFIED					

The information, design or data shown on this document or electronic media is the exclusive property of MI Windows and Doors, LLC. It is considered confidential and proprietary and is made available for limited use only. Its use or reproduction without the expressed written consent of MI Windows and Doors, LLC., is prohibited.

MI 8-Digit Part Number: WS40000G

Supplier: Amesbury
 Supplier Part Number: 751250GYAD3000

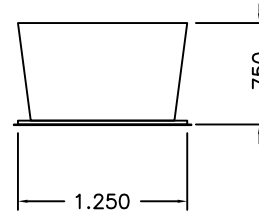
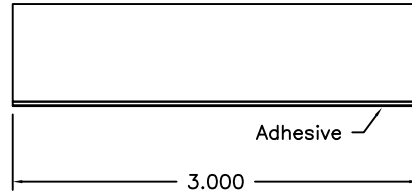



Molimo™
 Architectural Product Testing

Report #: 1435.05-106-12

Date: 5/9/2018

By: M. Stremmel

					MATERIAL: Pile W'Strip	 MI MI WINDOWS AND DOORS, LLC. 650 WEST MARKET STREET GRATZ, PA 17030-0370	DESCRIPTION: Weatherstrip Plug, Adhesive Backing Used Under/Over Interlocks		
					FINISH: Grey		UNSPECIFIED WALL:	PRODUCT: 12X, 13X, 14X SGD Families	DATE: 04/10/17
					AREA:		BREAK ALL CORNERS R.015, UNLESS OTHERWISE SPECIFIED	SCALE: 1 : 1	PART NUMBER: WS40000G
-	O41A-17	Initial release	04/10/17	T.C.	WEIGHT:			PERIMETER:	DFTM: T.C.
LTR	ECN #	REVISIONS	DATE	BY					

The information, design or data shown on this document or electronic media is the exclusive property of MI Windows and Doors, LLC. It is considered confidential and proprietary and is made available for limited use only. Its use or reproduction without the expressed written consent of MI Windows and Doors, LLC., is prohibited.

MI 8-Digit Part Number: WS40001G

Supplier: Amesbury
 Supplier Part Number: 751250GYAD1500

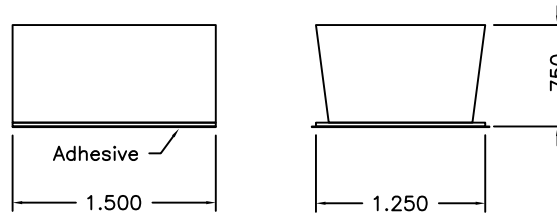

 **Molimo**TM
 Architectural Product Testing

Report #: 1435.05-106-12

Date: 5/9/2018

By: M. Stremmel

					MATERIAL: Pile W'Strip	 MI MI WINDOWS AND DOORS, LLC. 650 WEST MARKET STREET GRATZ, PA 17030-0370	DESCRIPTION: Weatherstrip Plug, Adhesive Backing Panel Top Bottom Rail Corners		
					FINISH: Grey		UNSPECIFIED WALL:	PRODUCT: 12X, 13X, 14X SGD Families	DATE: 04/10/17
					AREA:		BREAK ALL CORNERS R.015, UNLESS OTHERWISE SPECIFIED	The information, design or data shown on this document or electronic media is the exclusive property of MI Windows and Doors, LLC. It is considered confidential and proprietary and is made available for limited use only. Its use or reproduction without the expressed written consent of MI Windows and Doors, LLC., is prohibited.	
					WEIGHT:			SCALE: 1 : 1	PART NUMBER: WS40001G
-	O41A-17	Initial release	04/10/17	T.C.	PERIMETER:	DFTM: T.C.	DRAWING NUMBER: HW-000070		
LTR	ECN #	REVISIONS	DATE	BY					

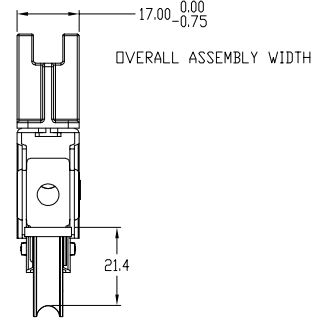
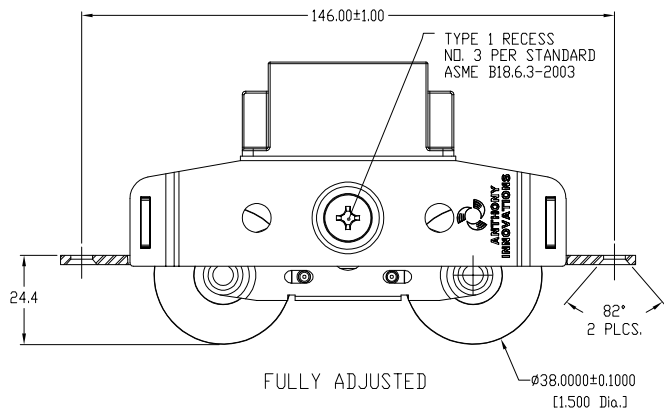
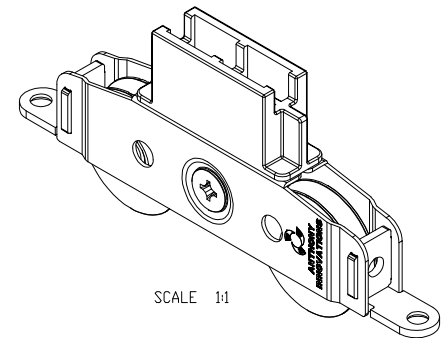
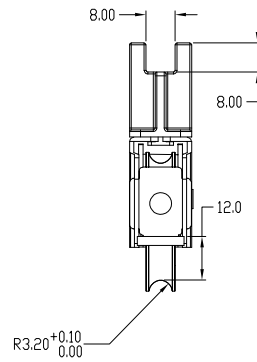
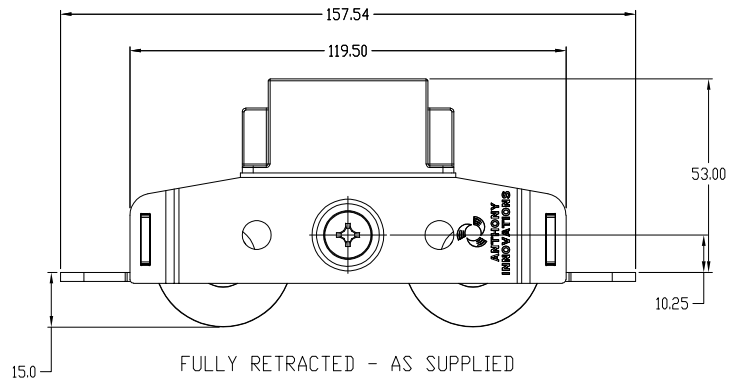

INNER AND OUTER CARRIAGE 1.2mm
END TAGS 2.2mm

ADJUSTMENT SCREW, BUSH
AND AXLES MADE FROM
303 STAINLESS STEEL.

PRECISION BEARINGS

ISO 492:2002
NORMAL TOLERANCE CLASS

ALL PLASTIC PARTS
ACETAL

CUSTOMER SIGNATURE REQUIRED FOR PRODUCTION APPROVAL &
ACCEPTANCE OF THE ANTHONY GROUP'S TERMS & CONDITIONS OF SALE
(DESIGN CHANGES SUBSEQUENT TO THIS SIGNATURE
MAY BE AT COST TO THE CUSTOMER)

SIGNED:.....DATE:.....

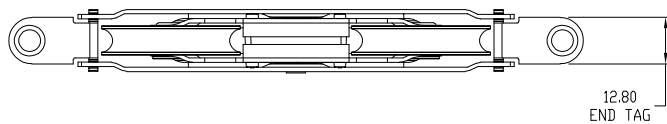



Report #: 1435.05-106-12

Date: 5/9/2018

By: M. Stremmel

PART NUMBER	CARRIAGE MATERIAL	BEARING MATERIAL	TYRE MATERIAL	LOAD RATING
S7143DNA	MILD STEEL	CHROME STEEL	ACETAL	80kg (176lb)
S7143DPA	MILD STEEL	CHROME STEEL	ACETAL	100kg (220lb)
S7143DGA	MILD STEEL	CHROME STEEL	MILD STEEL	100kg (220lb)
SS7143DSNA	STAINLESS STEEL	STAINLESS STEEL	ACETAL	80kg (176lb)
SS7143DSPA	STAINLESS STEEL	STAINLESS STEEL	ACETAL	100kg (220lb)
SS7143DSGA	STAINLESS STEEL	STAINLESS STEEL	STAINLESS STEEL	100kg (220lb)

DRAWN TO AS1100		DO NOT SCALE		UNSPECIFIED TOLERANCES ± 0.25	
30NOV16	-	RK	DJJ	DJJ	RELEASED FOR CUSTOMER APPROVAL
DATE	ECR No.	DRN	CKD	AUTH	REVISION

DESC.	DUAL WHEEL ROLLER	DRAWING No.	1082779	REVISION	
	 ANTHONY INNOVATIONS PTY LTD A MEMBER OF THE ANTHONY GROUP	ASSEM No.	REFER TABLE	CA1	
		DRAWING NAME	1082779 REV: 1.1		
		3D MODEL NAME	1082777 REV: .0	A2	
		DOC No.	18F		
					COPYRIGHT 2016 - ANTHONY INNOVATIONS

MI Drawing # HW-000071
MI 8-Digit Part # HD300300
Anthony Innovations Part # SS7143DSPA

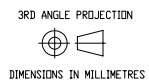

FINISH	COLOR	DESC.
MATL	SEE NOTES	
WEIGHT	-	MODIFIED BY Renu Kumar 30-Nov-16 04:00:00 PM
SCALE	1:1	CREATED BY Renu Kumar 30-Nov-16 02:00:00 PM
SHEET	1 OF 1	RELEASED BY Derek Jefferson 30-Nov-16 04:00:00 PM

THIS DOCUMENT IS THE PROPERTY OF ANTHONY INNOVATIONS PTY. LTD.
IT IS STRICTLY CONFIDENTIAL AND SUBJECT TO RETURN UPON REQUEST.
IT MUST NOT BE TRACED, COPIED OR EXHIBITED WITHOUT WRITTEN PERMISSION.

88 KEEN PARADE
HOMASTOWN, 3074
MELBOURNE, AUSTRALIA

www.anthonynovations.com.au
TEL +61 (0)3 9469 1166
FAX 7504522026