

DOOR HEIGHT	NUMBER OF SECTIONS REQD.	
	21" SECTIONS	24" SECTIONS
5'-3"	3	0
7'-0"	4	0
7'-6"	2	2
8'-0"	0	4
8'-9"	5	0
9'-0"	4	1
10'-0"	0	5
11'-0"	4	2
12'-0"	0	6
13'-0"	4	3
14'-0"	0	7
7'-9"	1	3
9'-3"	3	2
9'-6"	2	3
10'-6"	6	0
10'-9"	5	1
11'-6"	2	4
11'-9"	1	5
12'-6"	6	1
12'-9"	5	2

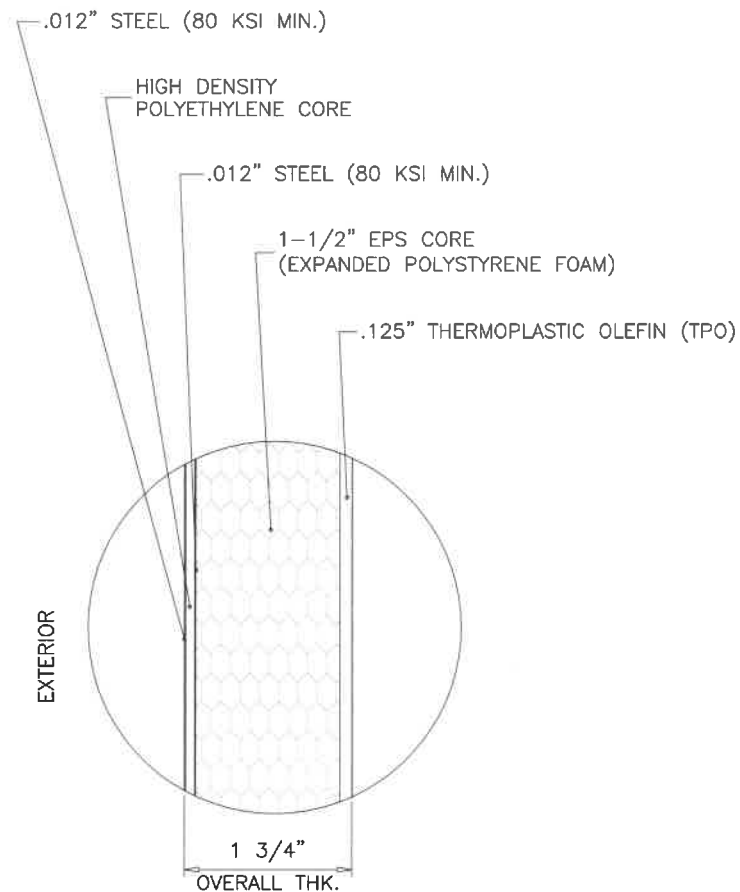

COMPOSITE SECTION DETAIL
EXTERIOR FINISHES HIGH GLOSS POLYSTER PAINT

THESE DOORS ARE RATED FOR LARGE MISSILE IMPACT. SHUTTERS ARE NOT REQUIRED.

TESTING IN ACCORDANCE WITH THE 2020 FLORIDA BUILDING CODE. LARGE MISSILE IMPACT TEST, TAS 201-94. CYCLIC WIND PRESSURE TEST, TAS 203-94. STATIC AIR PRESSURE TEST, TAS 202-94.

**Series 'DuraFlex' (12'-2")
High Impact Sectional Garage Door**

THIS PRODUCT HAS BEEN DESIGNED AND TESTED TO COMPLY WITH THE REQUIREMENTS OF THE 2018 INTERNATIONAL RESIDENTIAL CODE (IRC) AND 2018 INTERNATIONAL BUILDING CODE (IBC).

WOOD BUCKS & BUCK FASTENERS BY OTHERS, MUST BE DESIGNED AND INSTALLED ADEQUATELY TO TRANSFER APPLIED PRODUCT LOADS TO THE BUILDING STRUCTURE.

ANCHORS SHALL BE CORROSION RESISTANT, SPACED AS SHOWN ON DETAILS AND INSTALLED PER MANUF'S INSTRUCTIONS. SPECIFIED EMBEDMENT TO BASE MATERIAL SHALL BE BEYOND WALL DRESSING OR STUCCO.

A LOAD DURATION INCREASE IS USED IN DESIGN OF ANCHORS INTO WOOD ONLY.

MATERIALS INCLUDING BUT NOT LIMITED TO STEEL/METAL SCREWS, THAT COME INTO CONTACT WITH OTHER DISSIMILAR MATERIALS SHALL MEET THE REQUIREMENTS OF THE 2018 IRC/IBC.

THIS PRODUCT APPROVAL IS GENERIC AND DOES NOT PROVIDE INFORMATION FOR A SITE SPECIFIC PROJECT, i.e. LIFE SAFETY OF THIS PRODUCT, ADEQUACY OF STRUCTURE RECEIVING THIS PRODUCT AND SEALING AROUND OPENING FOR WATER INFILTRATION RESISTANCE ETC. CONDITIONS NOT SHOWN IN THIS DRAWING ARE TO BE ANALYZED SEPARATELY, AND TO BE REVIEWED BY BUILDING OFFICIAL.

DESIGN LOADS SHOWN ARE BASED ON 'ALLOWABLE STRESS DESIGN (ASD)'. MANUFACTURER'S LABEL SHALL BE LOCATED ON A READILY VISIBLE LOCATION IN ACCORDANCE WITH SECTIONS R613.4 AND R613.7.1 OF THE IRC AND SECTION 1714.5.1 OF THE IBC.

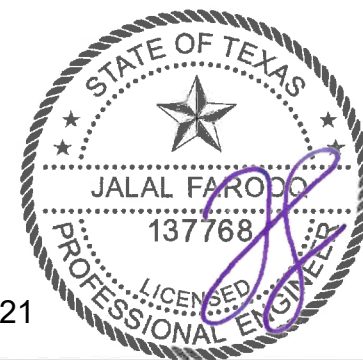

Sealed: 8/25/2021

AL-FAROOQ CORPORATION
ENGINEERS & PRODUCT DEVELOPMENT
9360 SUNSET DRIVE, SUITE 220
MIAMI, FLORIDA 33173
TEL. (305) 264-8100 FAX. (305) 262-6978
C.A.N. 3538

DuraFlex 12'-2" High Impact Sectional Garage Door
DuraServ Corp.
11431 Ferrell Drive, Suite 200
Farmers Branch, TX 75234
Tel: (800) 994-2361 Fax: (-)

revisions:	no	date	by	description

date: 07-09-21
scale: 1/2" = 1"
dr. by: TARIQ
chk. by:

drawing no.
21-57T
sheet 1 of 6

GARAGE\21-57T-DSC

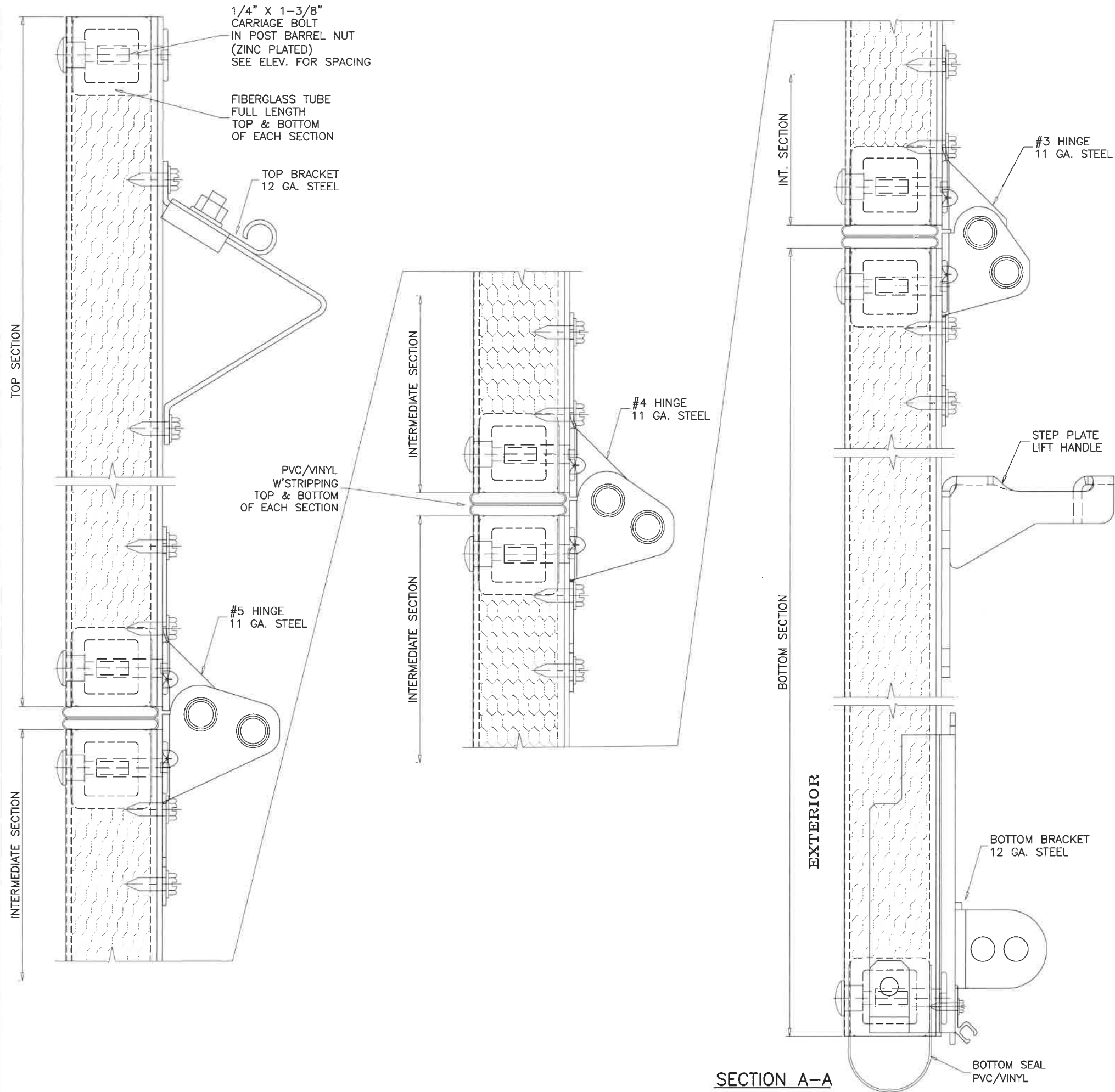

Sealed: 8/25/2021

af c
AL-FAROOQ CORPORATION
 ENGINEERS & PRODUCT DEVELOPMENT
 9360 SUNSET DRIVE, SUITE 220 (C.A.N. 3538)
 MIAMI, FLORIDA 33173
 TEL. (305) 264-8100 FAX. (305) 262-6978
 GARAGE\21-57T-DSC

DuraFlex 12'-2" High Impact Sectional Garage Door
DuraServ Corp.
 11431 Ferrell Drive, Suite 200
 Farmers Branch, TX 75234
 Tel: (800) 994-2361 Fax: (-)

revisions:	
no	date by description

date: 07-09-21	scale: 1/2" = 1"
dr. by: TARIQ	chk. by:

drawing no. 21-57T
 sheet 3 of 6

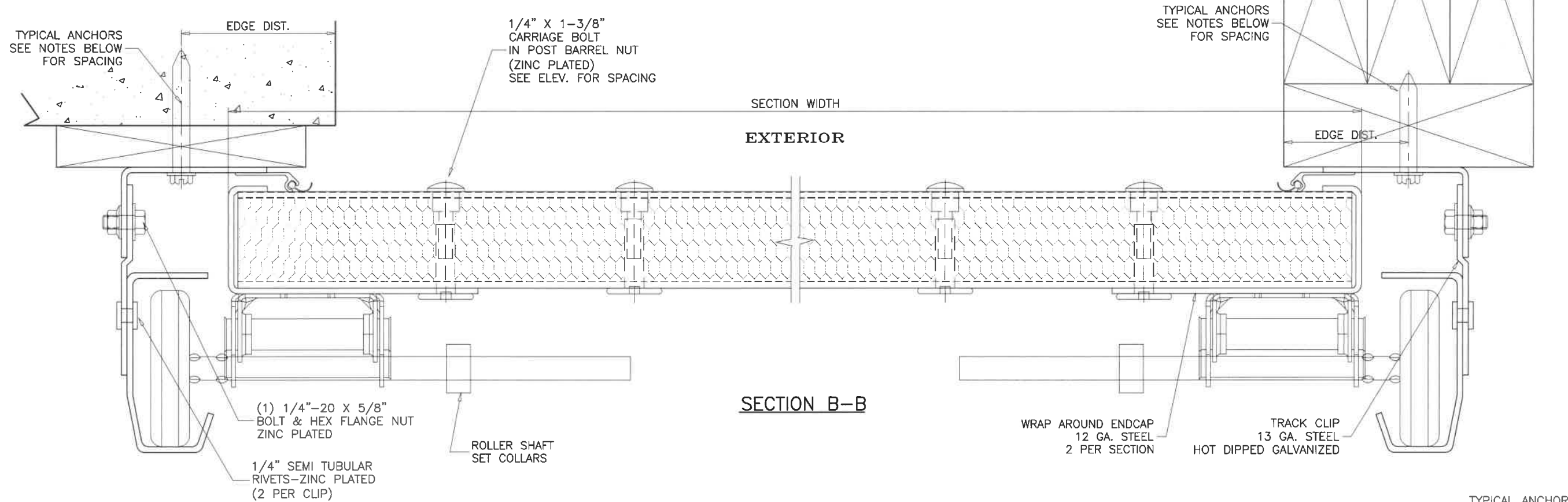

TYPICAL ANCHORS:

5/16" DIA. ULTRACON BY 'DEWALT' (Fu=177 KSI, Fy=155 KSI)

THRU 1BY OR 2BY BUCKS INTO CONCRETE
 1-3/4" MIN. EMBED INTO CONCRETE
 AT 4" FROM BOTTOM AND 6" O.C. MAX.

DIRECTLY INTO CONCRETE
 1-3/4" MIN. EMBED INTO CONCRETE
 AT 4" FROM BOTTOM AND 12" O.C. MAX.

3/8" DIA. KWIK BOLT-3 EXPANSION ANCHOR BY 'HILTI'

DIRECTLY INTO MASONRY
 2-1/2" MIN. EMBED INTO GROUT-FILLED BLOCKS
 AT 4" FROM BOTTOM AND 6" O.C. MAX.
 4" MIN. EDGE DISTANCE

5/16" DIA. DRIL-FLEX SELF DRILLING SCREWS BY 'DEWALT' (GRADE 5 CRS)

INTO METAL STRUCTURES
 AT 4" FROM BOTTOM AND 12" O.C. MAX.
 STEEL: 1/8" THK. MIN. (Fy = 36 KSI MIN.)
 (STEEL IN CONTACT WITH ALUMINUM TO BE PLATED OR PAINTED)

5/16" DIA. LAG SCREWS

INTO WOOD STRUCTURES
 2" MIN. PENETRATION INTO WOOD
 AT 4" FROM BOTTOM AND 6" O.C. MAX.

TYPICAL EDGE DISTANCE

INTO CONCRETE = 2-3/16" MIN.
 INTO FILLED BLOCKS = 4" MIN.
 INTO WOOD STRUCTURE = 1-1/2" MIN.
 INTO METAL STRUCTURE = 3/4" MIN.

WOOD SG = 0.55 MIN.
 CONCRETE f'c = 3000 PSI MIN.
 C-90 GROUT FILLED BLOCK f'm = 2000 PSI MIN.

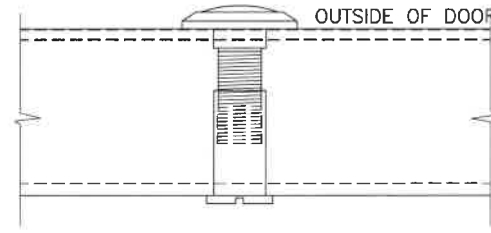

SOLID BRASS DOOR VIEWER
 BY 'SCHLAGE SECURITY HARDWARE'
 INSTALLED IN 9/16" DIA. HOLES
 POSITIONED AT EYE LEVEL

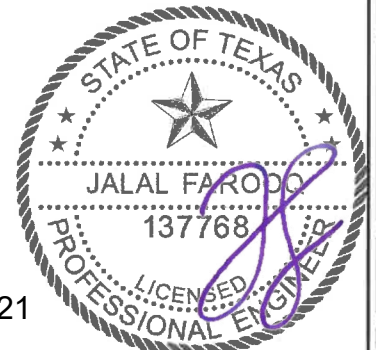
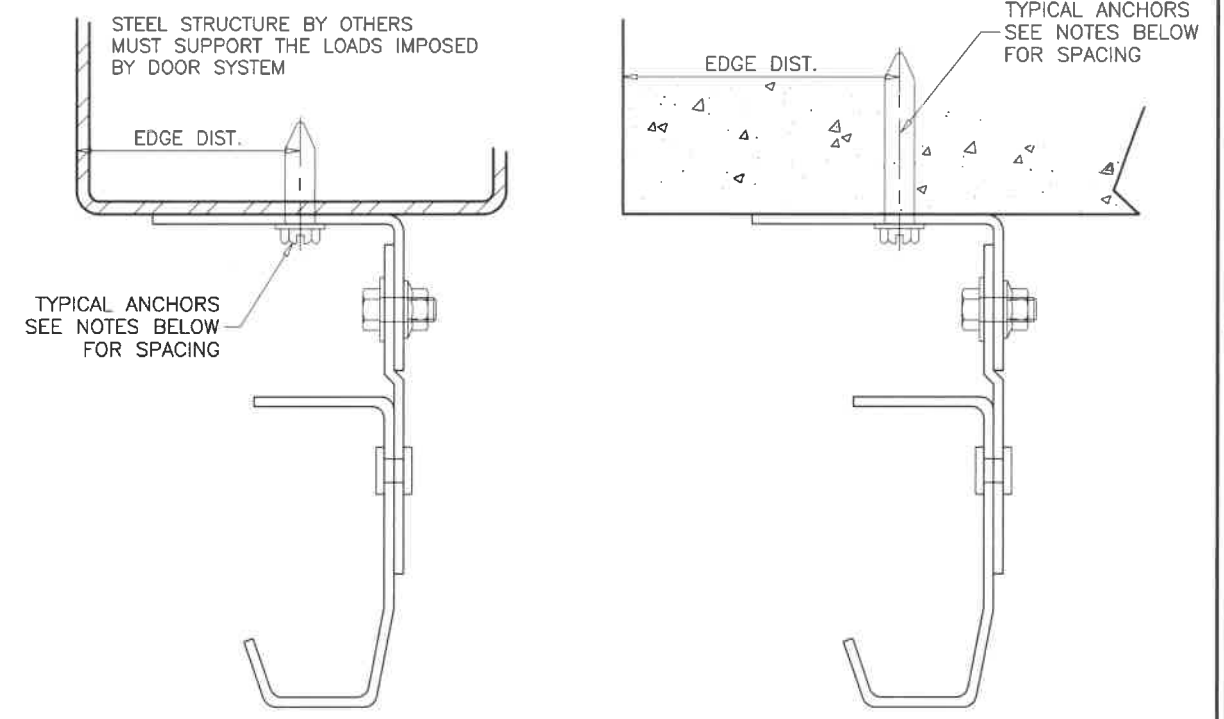

Sealed: 8/25/2021

af c
AL-FAROOQ CORPORATION
 ENGINEERS & PRODUCT DEVELOPMENT
 9360 SUNSET DRIVE, SUITE 220 (C.A.N. 3538)
 MIAMI, FLORIDA 33173
 TEL. (305) 264-8100 FAX. (305) 262-6978
 GARAGE\21-57T-DSC

DuraFlex 12'-2" High Impact Sectional Garage Door
DuraServ Corp.
 11431 Ferrell Drive, Suite 200
 Farmers Branch, TX 75234
 Tel: (800) 994-2361 Fax: (-)

revisions:	no	date	by	description
date:	07-09-21	scale:	1/2" = 1"	
dr. by:	TARIQ	chk. by:		
drawing no.	21-57T			
sheet	4 of 6			

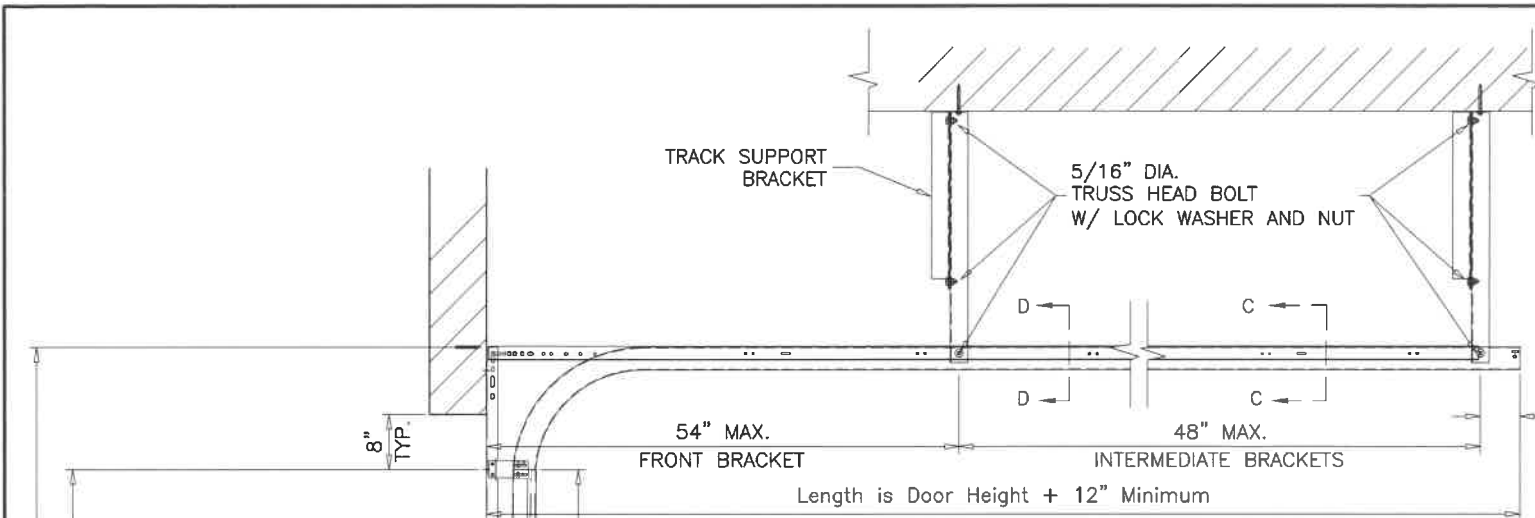

SUPPORT BRACKETS AT EACH TRACK

BRACKETS RUN PERPENDICULAR TO TRACKS
 FRONT AND END BRACKETS TO BE SPACED AS SHOWN ABOVE.
 ADDITIONAL INTERMEDIATE BRACKETS TO BE INSTALLED FOR SPACING MORE THAN 48" IN BETWEEN FRONT AND END BRACKETS.

BRACKET ANCHORS:

(3) 5/16" DIA. LAG SCREWS
 INTO WOOD STRUCTURES, (S.G.=0.50)
 1-1/2" MIN. PENETRATION

(2) 1/4" DIA. ULTRACON+ BY 'DEWALT' (Fu=164 KSI, Fy=148 KSI)
 INTO CONCRETE, 3000 PSI MIN.
 1-3/4" MIN. EMBED

ANCHORING TO CEILING OTHER THAN WOOD OR CONCRETE TO BE REVIEWED SEPARATELY.

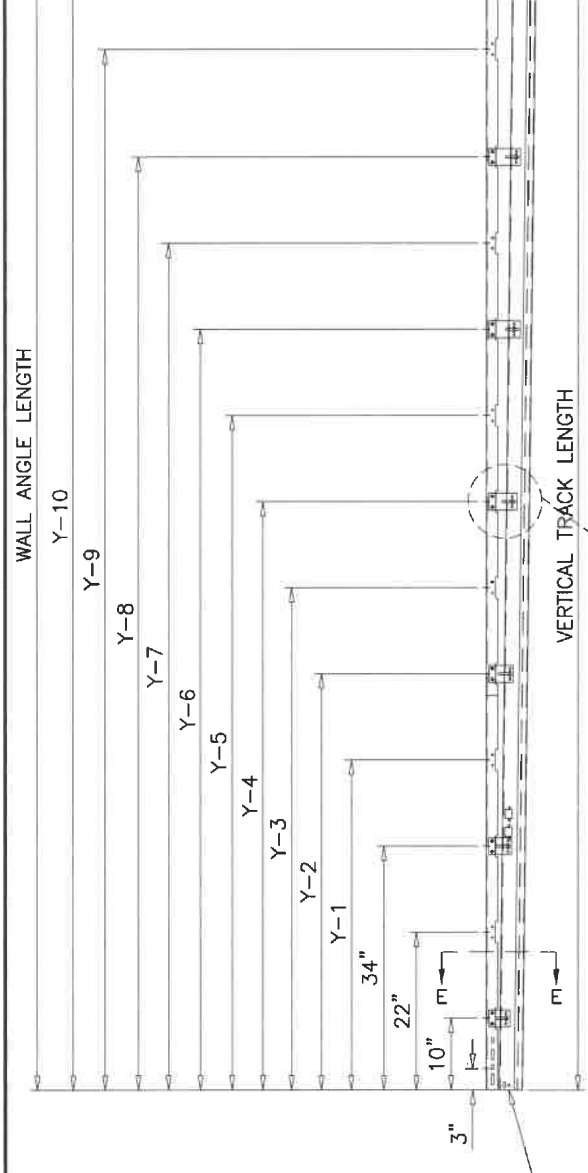
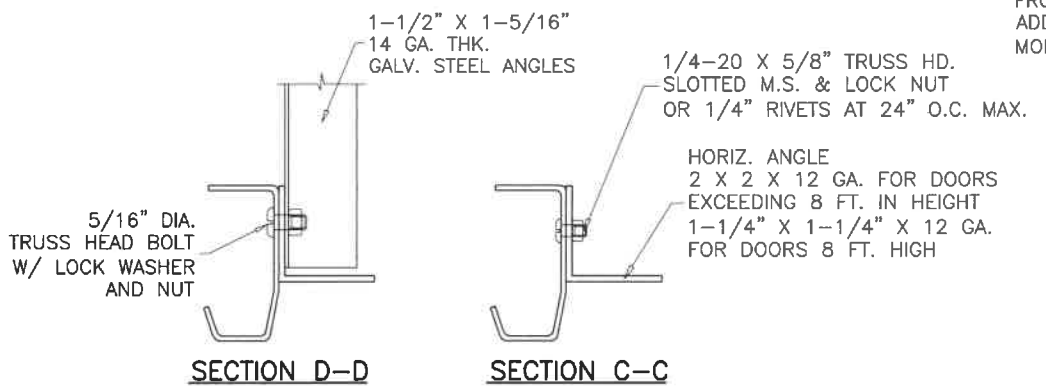

TRACK CONFIGURATION

DOOR HEIGHT	VERTICAL TRACK LENGTH	WALL ANGLE LENGTH	TRACK CLIP & ANCHOR SPACING											
			Y-1	Y-2	Y-3	Y-4	Y-5	Y-6	Y-7	Y-8	Y-9	Y-10		
5' 3"	55"	72"	44"	55"	70"	NA	NA	NA	NA	NA	NA	NA	NA	NA
7' 0"	76"	93"	46"	58"	67"	76"	NA	NA	NA	NA	NA	NA	NA	NA
7' 6"	82"	99"	46"	58"	70"	82"	NA	NA	NA	NA	NA	NA	NA	NA
8' 0"	88"	105"	46"	58"	73"	88"	NA	NA	NA	NA	NA	NA	NA	NA
8' 9"	97"	114"	46"	58"	70"	82"	97"	NA	NA	NA	NA	NA	NA	NA
9' 0"	100"	117"	46"	58"	70"	82"	91"	100"	NA	NA	NA	NA	NA	NA
10' 0"	112"	129"	46"	58"	70"	82"	97"	112"	NA	NA	NA	NA	NA	NA
11' 0"	124"	141"	46"	58"	70"	82"	94"	106"	151"	124"	NA	NA	NA	NA
12' 0"	136"	153"	46"	58"	70"	82"	94"	106"	121"	136"	NA	NA	NA	NA
13' 0"	148"	165"	46"	58"	70"	82"	94"	106"	118"	130"	139"	148"	NA	NA
14' 0"	160"	177"	46"	58"	70"	82"	94"	106"	118"	130"	145"	160"	NA	NA

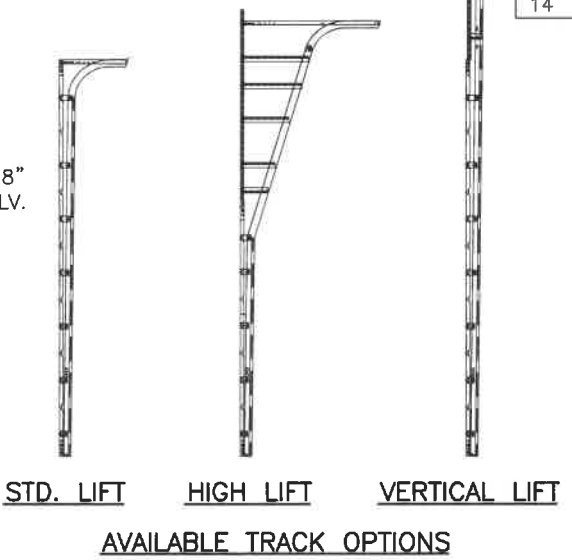

Sealed: 8/25/2021

AL-FAROOQ CORPORATION
 ENGINEERS & PRODUCT DEVELOPMENT
 9360 SUNSET DRIVE, SUITE 220
 MIAMI, FLORIDA 33173
 TEL (305) 264-8100 FAX (305) 262-6978
 (C.A.N. 3538)

DuraFlex 12' - 2" High Impact Sectional Garage Door

DuraServ Corp.
 11431 Ferrell Drive, Suite 200
 Farmers Branch, TX 75234
 Tel: (800) 994-2361 Fax: (-)

revisions: no date by description

date: 07-09-21 scale: - dr. by: TARIQ chk. by:

drawing no. **21-57T**

sheet 5 of 6

GARAGE\21-57T-DSC

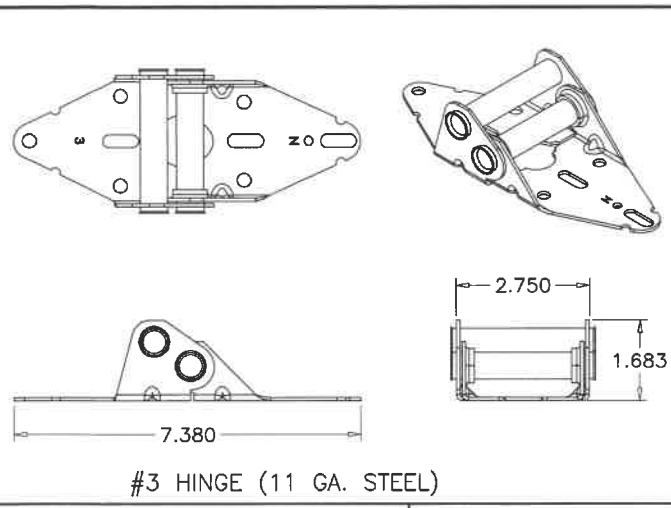

#3 HINGE (11 GA. STEEL)

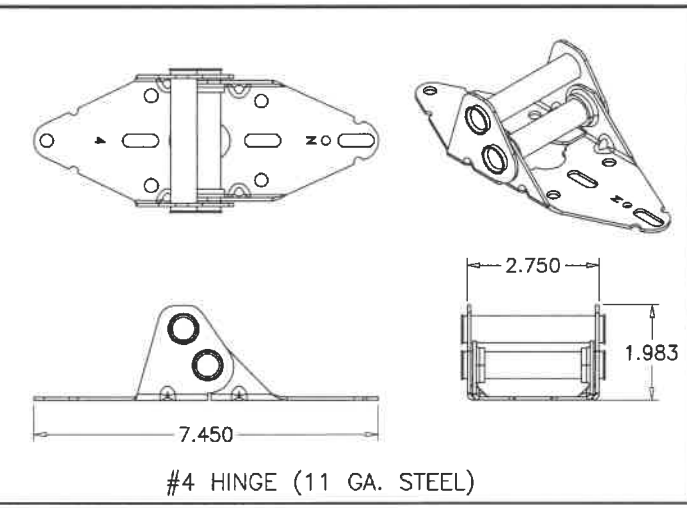

#4 HINGE (11 GA. STEEL)

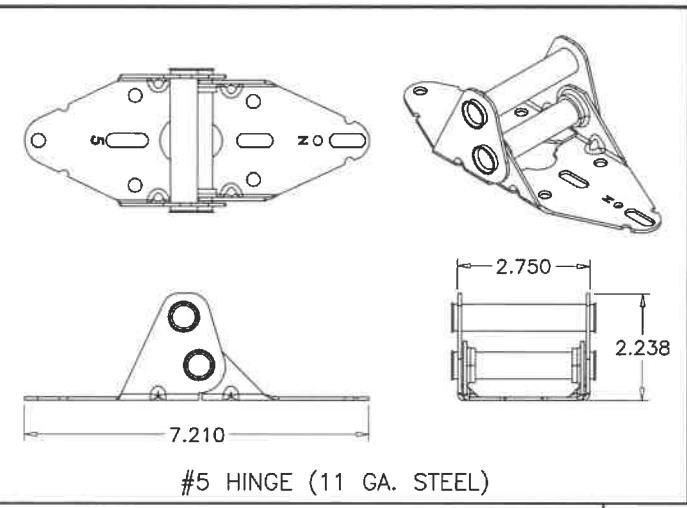

#5 HINGE (11 GA. STEEL)

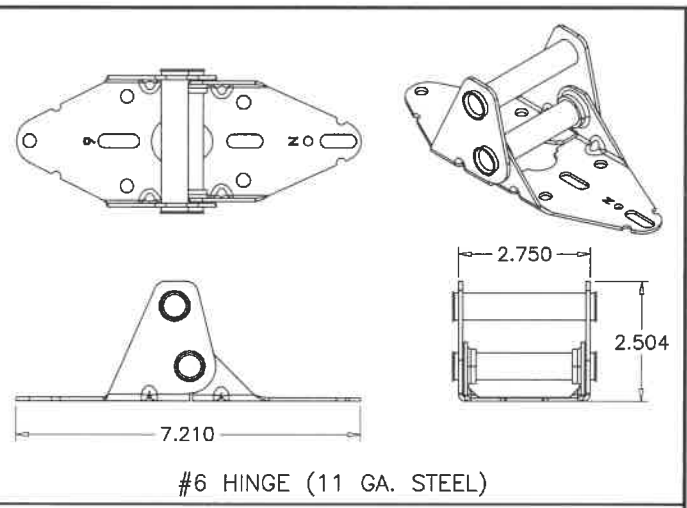

#6 HINGE (11 GA. STEEL)

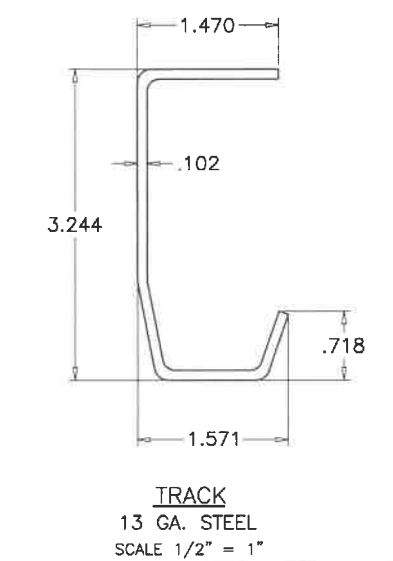

TRACK
13 GA. STEEL
SCALE 1/2" = 1"

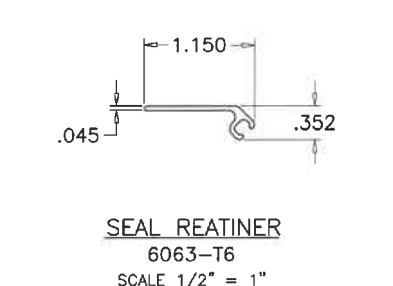

SEAL RETAINER
6063-T6
SCALE 1/2" = 1"

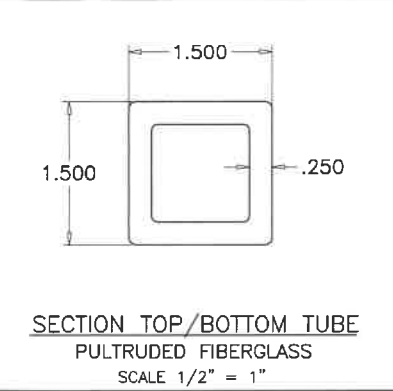

SECTION TOP/BOTTOM TUBE
PULTRUDED FIBERGLASS
SCALE 1/2" = 1"

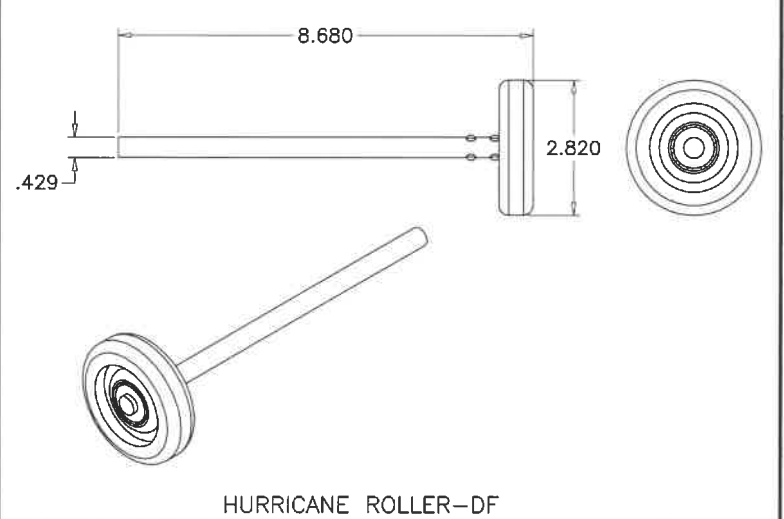

HURRICANE ROLLER-DF

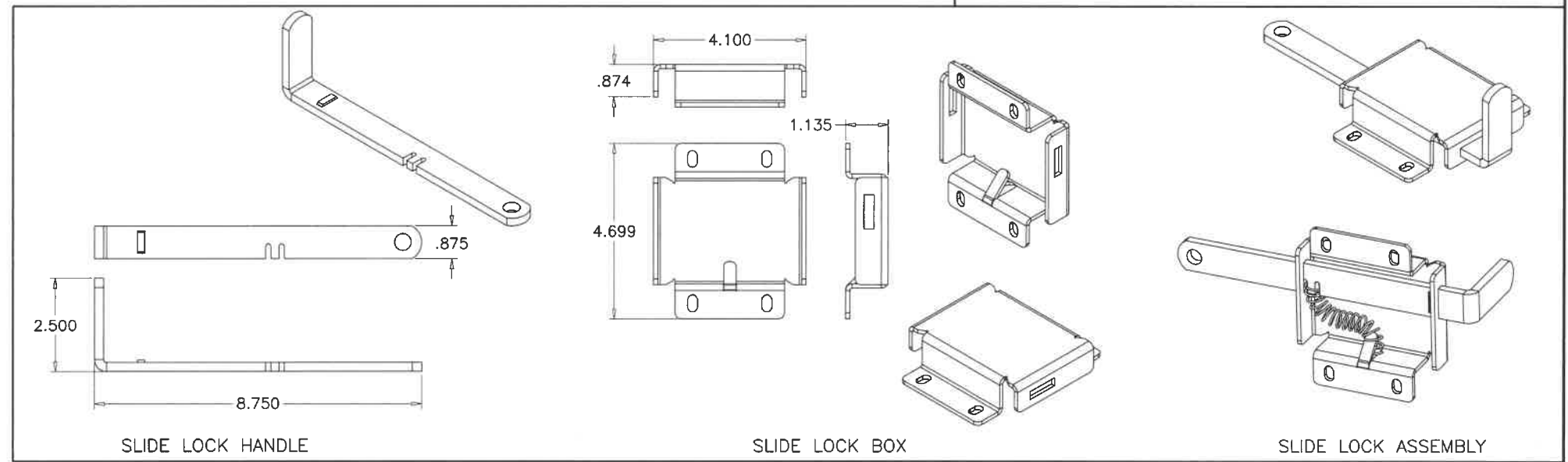

SLIDE LOCK HANDLE

SLIDE LOCK BOX

SLIDE LOCK ASSEMBLY

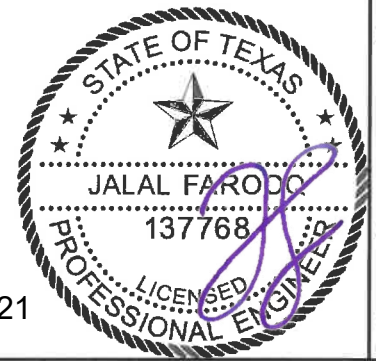

Sealed: 8/25/2021

af c
AL-FAROOQ CORPORATION
ENGINEERS & PRODUCT DEVELOPMENT
9360 SUNSET DRIVE, SUITE 220 (C.A.N. 3538)
MIAMI, FLORIDA 33173
TEL. (305) 264-8100 FAX. (305) 262-6978
GARAGE\21-57T-DSC

DuraFlex 12'-2" High Impact Sectional Garage Door
DuraServ Corp.
11431 Ferrell Drive, Suite 200
Farmers Branch, TX 75234
Tel: (800) 994-2361 Fax: (-)

revisions:	no	date	by	description

date: 07-08-21
scale: 1/4" = 1"
dr. by: TARIQ
chk. by:
drawing no.
21-57T
sheet 6 of 6